

Maintenance >>

Our congratulations and deepest thanks on making Ibanez your choice of instrument. Ibanez standards are second to none. All Ibanez instruments are set up to our strict quality control standards before shipping. The purpose of this manual is to explain how to maintain your instrument's finish and to keep your guitar playing as well as it did when it left our factory.

CLEANING

Regular cleaning of your guitar is one of the most important ways you can maintain the finish and lengthen string life. After playing, wipe down your instrument to remove any perspiration from the instrument. Perspiration can actually contain acids that can be corrosive to the strings and metal parts of the guitar. Gloss finish guitars should be polished with polish formulated specifically for musical instruments, and a soft, treated guitar cloth or a cotton rag. Abrasive rags such as polyester can scratch the finish. Oil finished guitars should be wiped clean immediately after playing with a dry cotton rag only. If your guitar has become discolored due to extended use or heavy perspiration, factory appearance, see a qualified guitar repair person about methods to restore the oil finish to its original factory appearance.

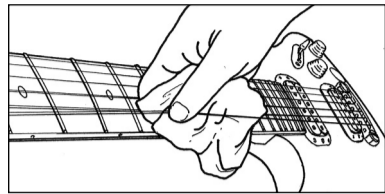

STRINGS AND TUNING MACHINES

If strings become dirty, discolored, or produce a dull sound or buzz, replace the strings with new ones. For best results we recommend replacing one string at a time, this will help to avoid removing the string tension from the neck. When replacing strings with different gauge strings, it may be necessary to adjust the truss rod tension. (We recommend only qualified technicians perform this.) Instruments that have tremolo systems installed may need to be adjusted after string replacement as changes in string tension can cause the tremolo to raise or lower. Ibanez guitars and basses are factory equipped with the following string gauges. Please follow the instructions below for your particular model. The strings should be tightly wound on to the tuning machines from top to bottom with 2 to 3 string wraps around the post. In the case of unwound guitar strings, the ends of the strings should be prepared as shown in the diagram to prevent unintentional slippage from the posts. In the case of tuning machines, where the string ends are inserted into the posts, the string can be cut to length in advance using a pair of string cutters.

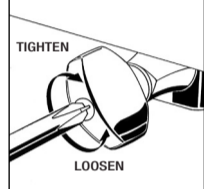
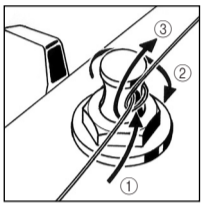
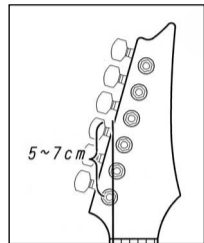

If the tuning machines are sealed gear units, they are self-lubricating types. The set screws for the tuning knob are adjustment screws that can be tightened with a small Phillips head screwdriver to increase the tension.

*The use of coarse strings may lead to buzzing and sound distortion. Using strings that have twists or kinks may cause buzzing or decreased sustain. Make sure that the new strings are smooth and free from any defects before installing.

STRING GAUGES	TREBLE SIDE	BASS SIDE
Solid guitars w/Tremolo, JTK, ICX, RVX & ALL Gio	.009/.011/.016/.024/.032/.042 inch	1.5mm 2.0mm
RG321MH, SZ, AXS, AR, ARC, ARX & IC	.010/.013/.017/.026/.036/.046 inch	1.7mm 2.3mm
7-String model	.010/.013/.017/.026/.036/.046/.054 inch	
MMM1	.014/.017/.030/.040/.056/.074 inch	

Guitar Electronics >>

SWITCHING FUNCTION

Ibanez Instruments are unique in the simplicity and versatility of our switching systems. Each model was designed to allow the maximum amount of useful pickup positions with the simplest operations.

SPLITS FUNCTION WITH "TRUE-DUO" SYSTEM *BRIDGE PICKUP: "TRUE-DUO BUCKER"

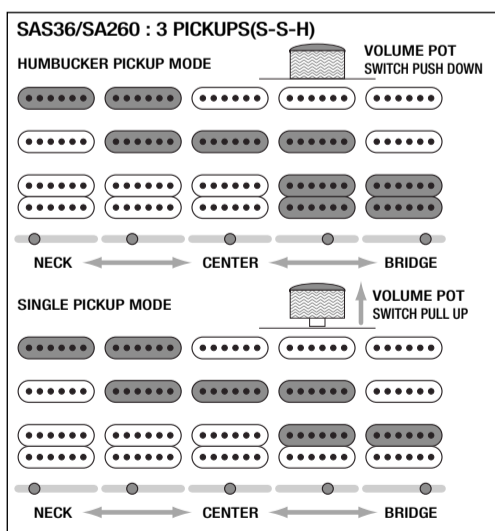
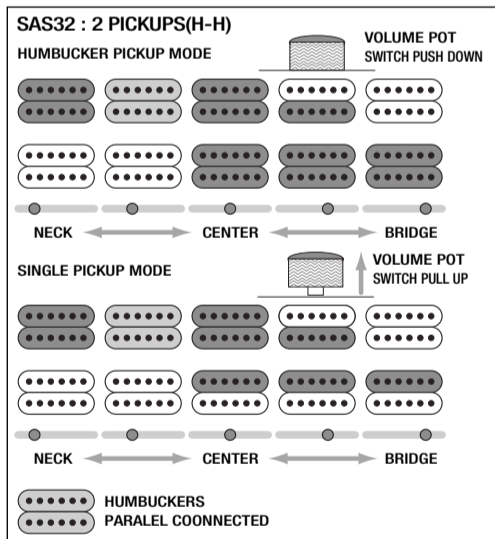

SPLITS FUNCTION

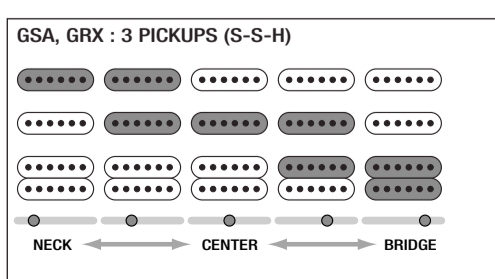
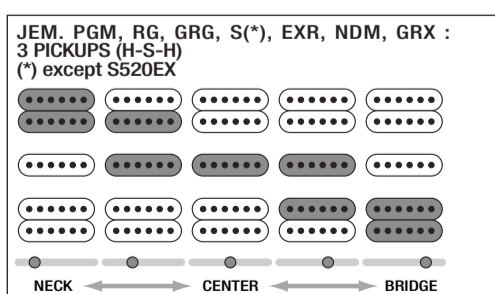

NECK

Ibanez steel string models are equipped with adjustable truss rods. The purpose of a truss rod is to adjust the neck to counteract string tension. There are many reasons for truss rod adjustments. One of the most frequent reasons is changing string gauges or tuning pitch which can affect string tension. String tension changes may affect the string height and cause fret buzz or notes that don't ring true. To adjust the truss rod, locate the truss rod nut and adjust it by inserting the correct wrench into the nut and tightening (clockwise) or loosening (counter clockwise) the rod. Truss rod tension can be measured by installing a capo at the first fret holding the strings down at the fret position where the neck joins the body. Insert a thickness gauge between the string and the fret at the 8th fret. There should be between 0.3 mm to 0.5mm clearance. That clearance is referred to as "neck relief." Too much neck relief can cause the neck to have higher action in the middle of the neck causing poor intonation and uncomfortable playability. No neck relief can cause fret buzz.

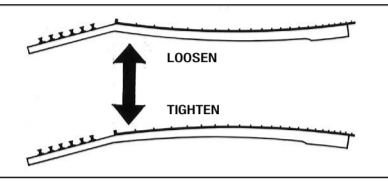
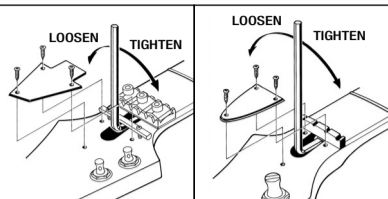

*Appropriate care must be taken when adjusting the neck and we recommend only qualified technicians perform this procedure.

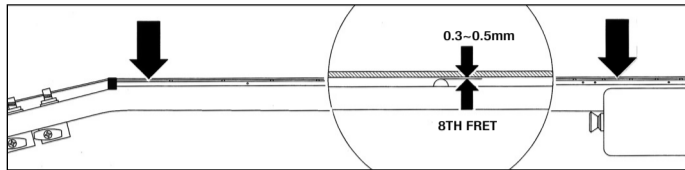

ACTION

Ibanez guitar and bass string action is set at the factory. However there are many reasons that an instrument's string height can change. Instruments can be affected by changes in temperature and moisture. High string action can make the guitar difficult to play. If the string action is too low, fret buzz or unclear notes can occur. To remedy this, follow the instructions for the particular type of bridge installed. In the case of string action, make sure the guitar is in tune and the truss rod is adjusted properly. Ibanez action is set at the 14th fret. The action may also need to be readjusted after the neck has been adjusted or strings have been changed to a different gauge. Follow the instructions in the relevant bridge manual to make adjustments.

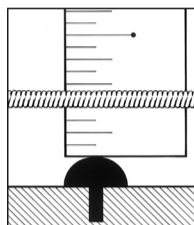

*If strings other than those described above are used, gradually increase the action clearance from the treble side through to the bass side.

	TREBLE SIDE	BASS SIDE
.009-string's guitars except Gio Ibanez	1.5mm	2.0mm
All Gio Ibanez & .010-, .014- string's guitars	1.7mm	2.3mm

INTONATION

Intonation adjustment is the operation of adjusting the location of the string at the saddle to compensate for different string gauges or different tunings. Follow the instructions of the particular bridge intonation below. Intonation is properly set when the 12th fret note and the 12th fret harmonic are exactly the same note. This is the center point of the scale and the most accurate way of setting a standard scale length. With the harmonic note as the standard, if the fretted note is flat move the bridge saddle forward toward the headstock (a) to decrease the string length. If the fretted note is sharp, move it back away from the headstock (b) to increase the string length intonation adjustments.

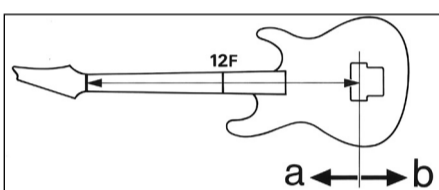

*Please note that strings can be broken when the saddle is moved, so always loosen the strings before making adjustments.

PICKUPS

The output level of the instrument as well as the quality of the signal can be affected by the pickup height. Pickup height should be adjusted until the volume of neck and bridge pickups are almost equal with both volumes wide open. The volume may drop drastically if the pickup height is too low. As the pickups are magnetic, fret buzzing and distortion may occur if the pickup is too close to the strings. Use a small screwdriver to make adjustments to raise or lower the pickup.

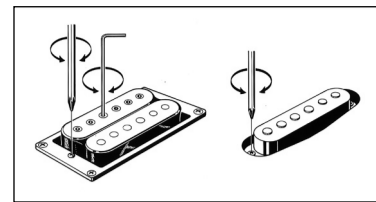

*Instruments that have adjustable pole pieces can be adjusted to balance the output of each string.

Guitar Bridges >>

GIBRALTAR CUSTOM BRIDGE

The height adjustment can be adjusted by 4 pcs of 2.0mm allen screws (B) on the bridge. Since the adjustment screws are locked by the bridge lock screw (A), you must loosen the bridge lock screw by 3.0mm Allen wrench before adjustment. Each saddle is also locked by a saddle lock screw (C). To adjust the intonation, use a 2.0mm Allen wrench to loosen the saddle lock screws, and then adjust the Intonation screw (D) by a 2.0mm Allen wrench. When you are finished with the adjustment, lock the saddle and tune the guitar.

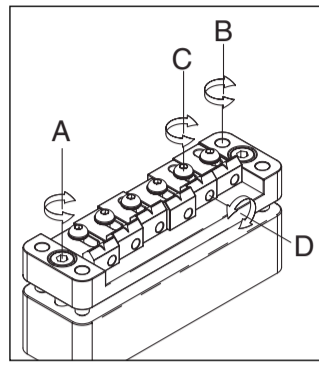

GIBRALTAR III & FULL TUNE III

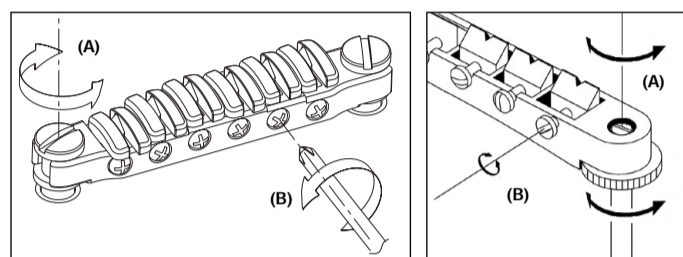

The action can be adjusted by using a slot head (-) screwdriver to turn the adjustment bolt at either end (A). The intonation can be adjusted by moving the saddle forward or backward using a screwdriver to turn the adjustment screw of each saddle (B).

HARDTAIL BRIDGE

To change strings, thread the new strings through the string grommets located on the back of the guitar and bring them up and over the saddle. The intonation can be adjusted by adjusting the saddle forward or backward using a Phillips (+) head screwdriver on the intonation adjustment screw at the rear of the bridge. String height is controlled by raising or lowering the small Allen screws using a wrench on either side of the saddle.

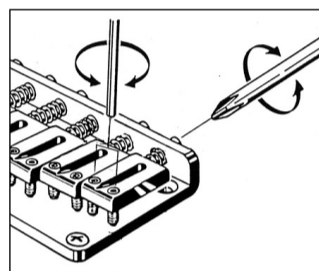

QUIK CHANGE TAILPIECES

The height adjustment of the QUIK CHANGE III can be adjusted by using a slot head (-) screwdriver or a coin turn the adjustment studs at either side of the tailpiece (C).

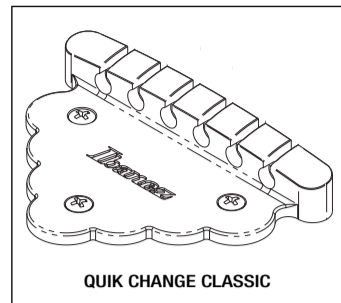
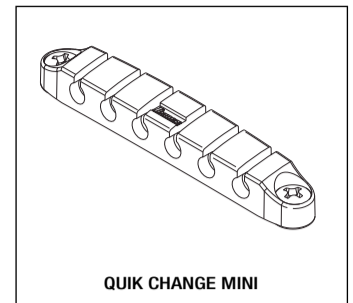
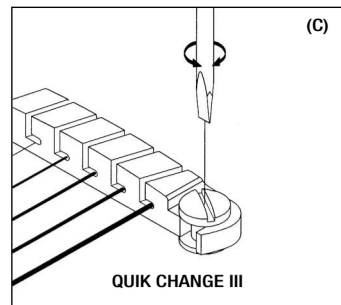

QUIK CHANGE ULTRA / FINE TUNING FUNCTION

QUIK CHANGE ULTRA has FINE TUNER function. Even after by the tuning machine, you can make a quick-fine adjustment by FINE TUNERS (E).

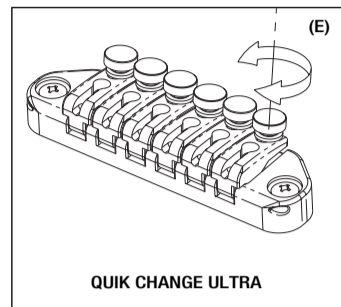

DOWNSHIFTER

INSTALLING THE STRING

To install a new string insert the ball end of the new string into the slot and place the ball end into the internal hook area of the saddle as shown. Pull the string tight to the saddle and resting the rest of the string as you normally would on the machine head.

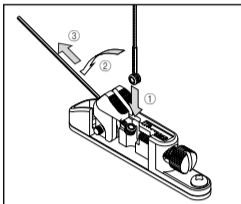

SPECIAL TUNING

The Downshifter also allows the pitch to be raised by setting the standard tuning while the lever is in the lower position. When the lever is raised the pitch will also be raised and can be adjusted to the desired pitch.

The Ibanez DOWNSHIFTER allows the pitch of a string to be dropped to a preset desired position with a simple lever operation. To achieve precise tuning for both the up and down positions, you will need to preset both lever settings before operating the Downshifter.

TUNING

First check that the Downshifter lever arm is raised to the up position then tune the string normally using the standard tuning machines on the headstock. (Note: The Downshifter tuning screw has no effect on the pitch in the up position.) Next, lower the lever on the Downshifter to the down position and the pitch of the string will drop down. Adjust the rear tuning screw clockwise to reduce the pitch, or counter clockwise to raise the pitch. This adjustment can be done by hand or with a standard screwdriver or a coin until the desired down pitch is acquired. (The preset factory pitch is set one whole step down to D.) When the lever is raised to the up position, the thumbscrew can be turned freely but will have no effect on the raised lever pitch. However, it will affect the settings of down lever pitch.

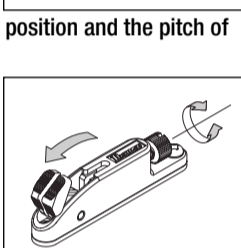
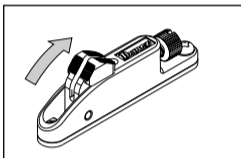

PLEASE NOTE: The Downshifter device was designed to provide the highest level of pitch accuracy. However, it should be understood that the Downshifter is a mechanical device. Pitch variations and tuning readjustments, especially after frequent use, are to be expected.

Guitar Controls >>

CONTROLS

1 VOL, 1 TONE & 5 WAY LEVER SELECTOR

JEM, PGM, NDM, RG, SAS, SA, GSA60, GRX70,40

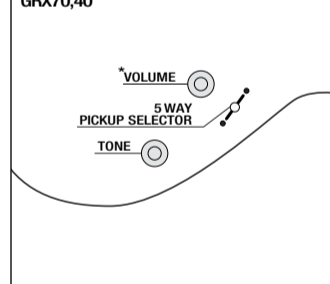

1 VOL, 1 TONE & 3 WAY LEVER SELECTOR

MMM, RG120, S520EX, GSA20, GRX20,22, GAX30

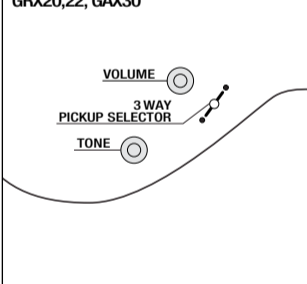

1 VOL, 1 TONE & 3 WAY TOGGLE SWITCH

ICX, RVX

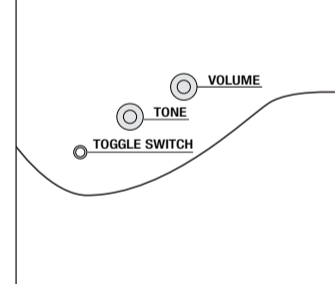

2 VOL, 1 TONE & 3 WAY TOGGLE SWITCH

SZ, ARC, ARX

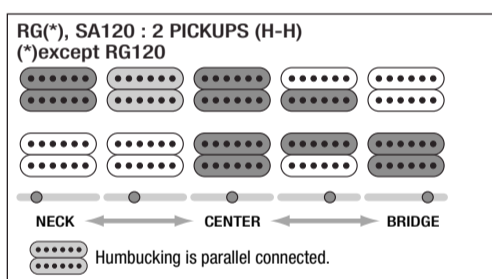
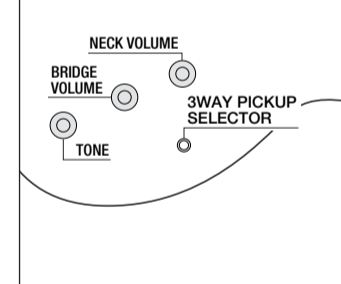

OTHERS

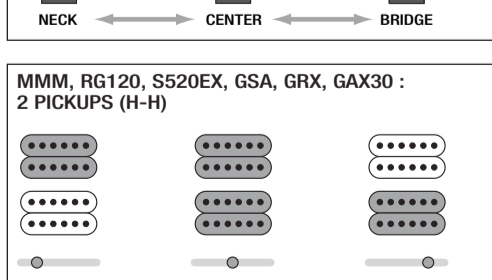
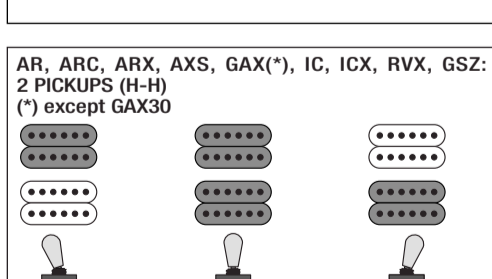
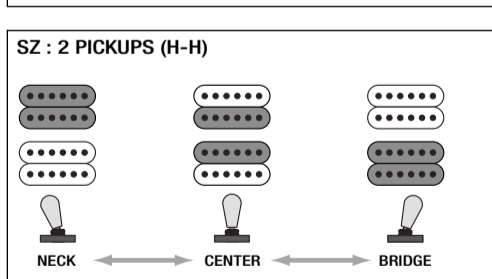
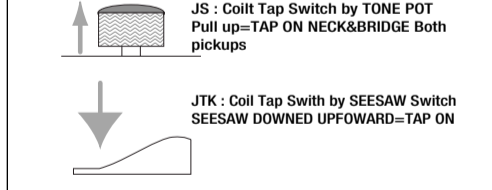
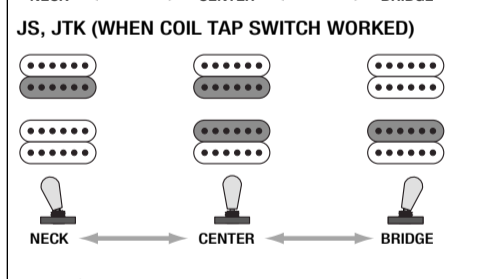
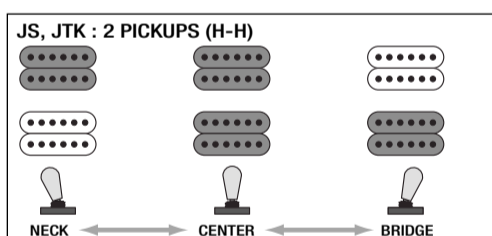

1 VOL, 1 TONE(*) & 3 WAY TOGGLE SWITCH

JS

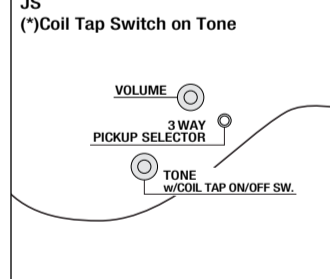

1 VOL, 1 TONE & 3 WAY TOGGLE SWITCH & 2 SEESAW SWITCHES

JTK

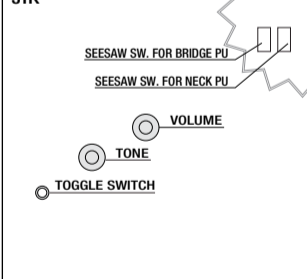

2 VOL, 2 TONE & 3 WAY TOGGLE SWITCH

AR, IC

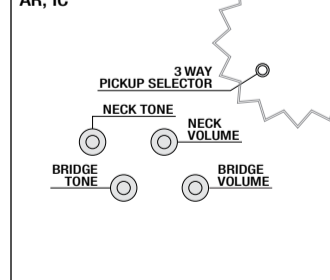

2 VOL, 1 TONE & 3 WAY TOGGLE SWITCH

GSZ

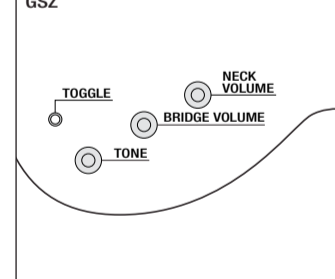

2 VOL, 2 TONE & 3 WAY TOGGLE SWITCH

AXS, AX, GAX70,75

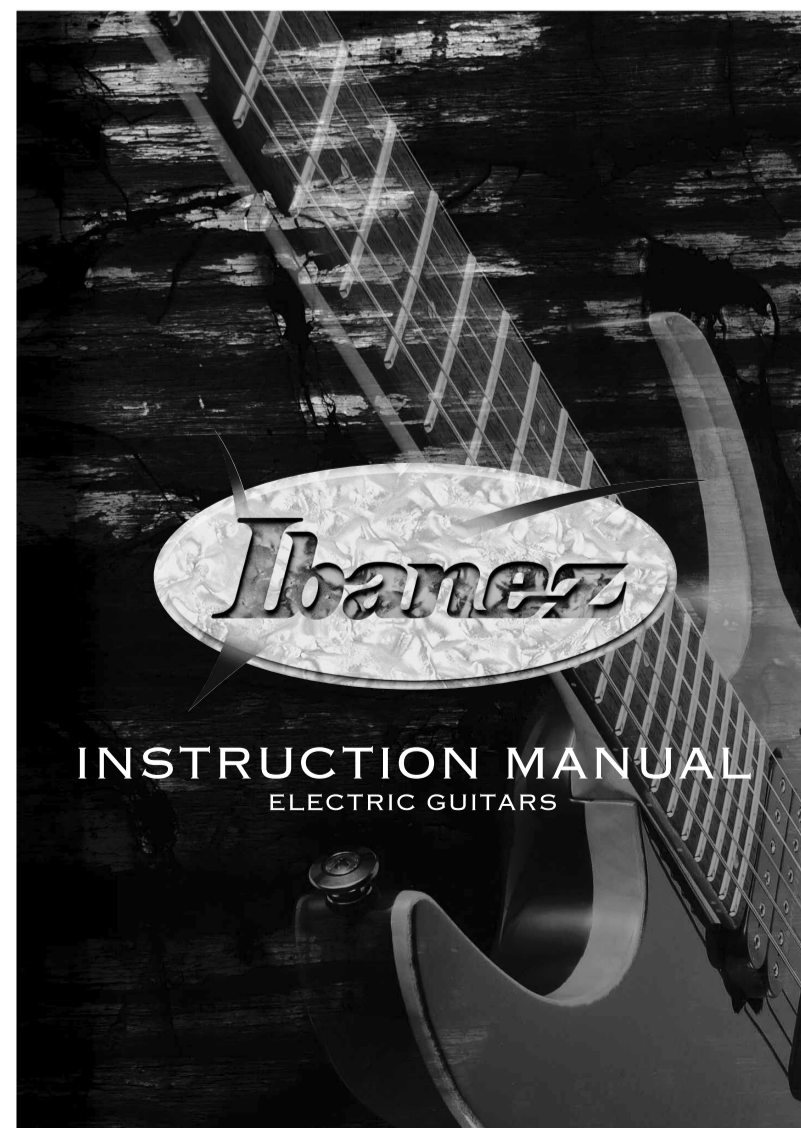
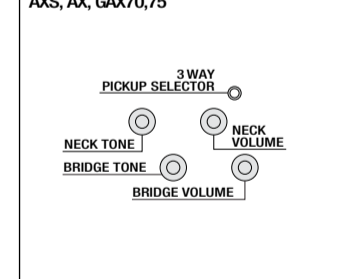

Ibanez
Printed in China AUG2005WEG ©2005

This is to certify that the aforementioned equipments fully conform to protection requirements of the following EC council directives. DIRECTIVES: 89/336/EEC Electromagnetic compatibility



Tremolos >>>

EDGE PRO II TREMOLO

TREMOLO ARM INSTALLATION

The tremolo arm can be inserted and removed very easily. Insert the arm into the armhole on the tremolo base plate. Pull up on the arm to remove it.

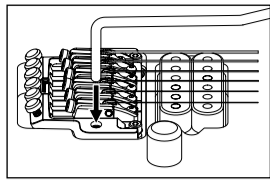

ARM ROTATION TORQUE

The rotation torque of the arm can be adjusted by raising the tremolo and inserting a 2.0mm Allen wrench in the screw (A) on the tremolo block. Turning this screw clockwise will tighten the arm torque and turning the screw counter clockwise will loosen the arm torque.

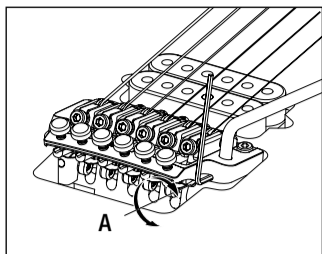

ARM ACTION

The tremolo arm action can be adjusted by using a 2.0mm Allen wrench on the screw (B) of the tremolo block.

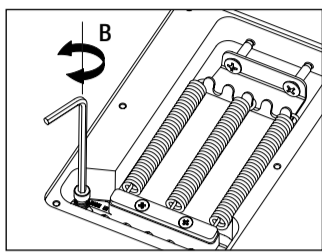

FINE TUNING

Even after locking the locking nut, you can use the fine tuners to make fine adjustments to the tuning of each string. You should adjust all of the fine tuners (C) to the center of their adjustable range before you lock the locking nut.

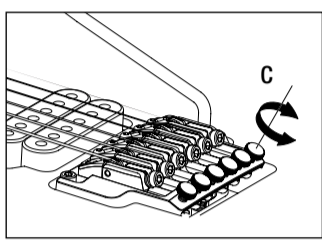

ADJUSTING THE ACTION

To adjust the entire tremolo unit up or down, use an Allen wrench to turn the stud bolt (E) located at the left and right of the tremolo unit. (This cannot be adjusted for each individual string.)

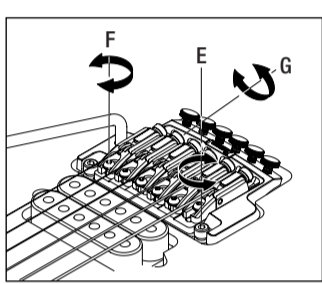

ADJUSTING THE INTONATION

Before you adjust the intonation, use a 3 mm Allen wrench to loosen the pressure pad screws (G) of the locking nut so that the strings are released. Use a 2 mm Allen wrench to loosen the saddle lock screws (F) of each saddle, and move the saddle. Firmly tighten the saddle lock screws, tune the guitar, and then check the intonation. Repeat these adjustments until the intonation is correct, and then tighten the pressure pad screws of the locking nut. You may install each saddle lock screw in either the forward or rear position, depending on the position of the saddle. The unit is designed so that the fine tuning screw will not operate if the position of the saddle extends beyond the front edge of the base plate.

Note: When loosening the saddle lock screws, you must loosen the strings sufficiently before making adjustments.

REPLACING THE STRINGS

The EDGE-PRO II tremolo will accommodate either strings from which the ball end has been cut, or conventional strings from which the ball end has not been cut. To remove a string, use a 3 mm Allen wrench to loosen the pressure pad screw of the locking nut (Fig.1), remove the string from the tuning machine, and use a 3 mm Allen wrench to loosen the string stopper screw of the saddle (Fig.2). Turning this counter-clockwise will automatically retract the holder block, so loosen the string stopper screw all the way until the holder block stops retracting. Remove the old string, insert approximately 3 cm of the new string with ball end into the saddle, and while making sure that the string is positioned in the center of the saddle, tighten the string stopper screw (Fig.2). Turning this clockwise will automatically advance the holder block, so after making sure that the string is firmly fastened, wind the string around the tuning machine post, tune it, and then tighten the pressure pad of the locking nut.

When installing a wound string from which the ball end has been cut off, you can leave the overwound portion of the winding intact in order to prevent the winding from loosening. Insert approximately 1-3 cm of the tip into the saddle, and install the string in the same way as a conventional string from which the ball end has not been cut off. Since the attachment angle of the tremolo will change significantly if all strings are removed at once, you should replace the strings one at a time. On the bottom of each saddle there is a guide stopper that indicates the length of string to be inserted. The appropriate length will be inserted if you insert the string until the tip contacts this guide. If a string breaks at the saddle, it may fall into the tremolo cavity when you loosen the string stopper screw. Remove the broken string either by detaching the tremolo spring cavity cover plate from the back of the guitar, or from the opening in the cover plate. If the broken string remains in the saddle, remove it from above.

Note: Before you tune a string, make sure that the string stopper screw is firmly tightened. Note: To prevent the string stopper screw from falling out, do not loosen it more than three turns after the holder block has stopped retracting.

TREMOLO SPRINGS

The EDGE-PRO II tremolo is designed to function optimally when it is installed approximately parallel with the surface of the guitar body (Fig.4). The angle at which the tremolo is attached can be adjusted by changing the length of the tremolo springs inside the tremolo spring cavity in the back of the guitar body. Working through the adjustment holes in the tremolo spring cavity cover plate, use a Phillips (+) screwdriver to turn the tremolo tension adjustment screws to adjust the length of the tremolo springs. If the tremolo is tilted forward toward the neck of the guitar (Fig.5), turn the screws clockwise to tighten the springs. Conversely, if the tremolo is tilted backward away from the neck (Fig.6), turn the screws counter-clockwise to loosen the springs. Tune the guitar accurately, re-check the angle of the tremolo, and repeat the adjustment until the tremolo angle is correct. The EDGE-PRO II tremolo is designed to function optimally when three springs are tensioned equally with a 0.009" gauge set of strings installed. If you replace the strings with a different gauge set, you can adjust the tremolo angle by changing the number of springs or the way in which the springs are installed. Loosen all strings before you add or remove a tremolo spring. The EDGE-PRO II tremolo uses a block lock mechanism to fasten the tremolo springs to the block. Before you change the number of springs or the way in which they are installed, use a Phillips (+) screwdriver to remove the block lock (Fig.7).

Note: If you want to install four or five tremolo springs, insert the springs into the block nut attachment screw holes. (In this case, it will not be possible to attach the block nut.)

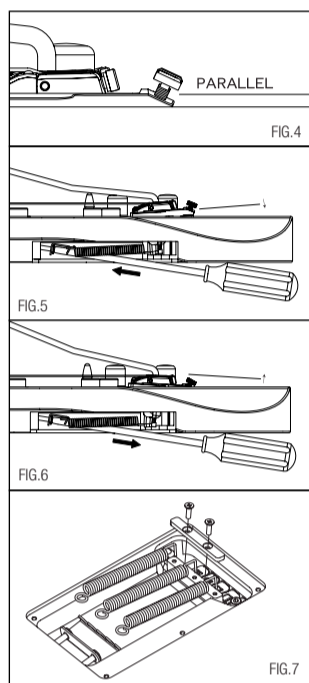
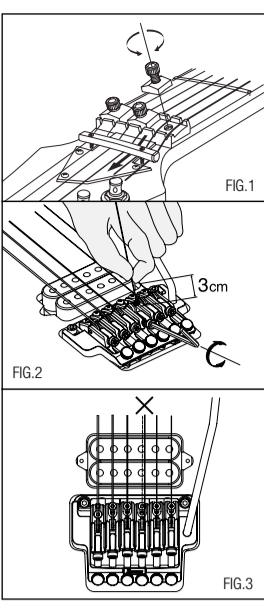

ZR (ZERO RESISTANCE) TREMOLO

TREMOLO ARM

Loosen the screw cap, insert the arm into the tremolo unit, and rotate it to fasten it in place (Fig.8). Rotate the arm to adjust it to the desired height. The arm torque is adjusted by the tightness of the screw cap. To remove the arm, loosen the screw cap and rotate the arm counter-clockwise (Fig.9).

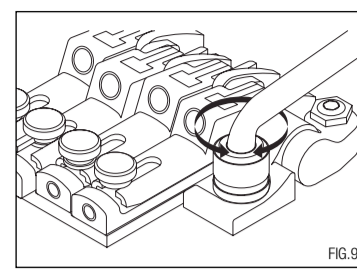
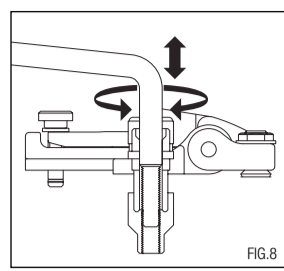

FINE TUNING

Even after locking the locking nut, you can use the fine tuners (Fig.10 A) to make fine adjustments to the tuning of each string. You should adjust all of the fine tuners to the center of their adjustable range before you lock the locking nut.

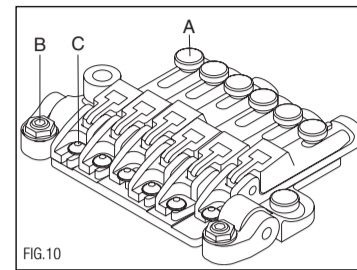

ADJUSTING THE ACTION

To adjust the entire tremolo unit up or down, use an Allen wrench to turn the stud bolt (Fig.10 B) located at the left and right of the tremolo unit. (This cannot be adjusted for each individual string.)

ADJUSTING THE INTONATION

Loosen the string stopper bolt of the locking nut (Fig.11). Remove the intonation adjustment bolt (Fig.12 B) from within the bridge unit, fasten it into the screw hole in the rear of the saddle, and tighten it so that the tip of the bolt contacts the boss of the bridge unit. Loosen the saddle lock bolt (Fig.10 C), and turn the intonation adjustment bolt to adjust the position of the saddle. After completing the adjustment, tighten the saddle lock bolt sufficiently to prevent the saddle from moving forward during tuning, and store the intonation adjustment bolt inside the bridge unit.

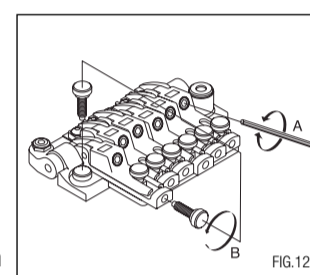
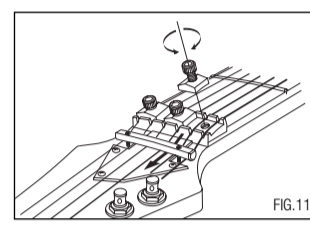

REPLACING THE STRINGS

Loosen the string stopper bolt of the locking nut (Fig.11), completely loosen the string at the tuning machine, use an Allen wrench to loosen the string stopper bolt of the bridge saddle (Fig.12 A), and remove the old string. Use wire cutters to remove the ball end from the new string as shown in Figure 13, insert this end of the string into the bridge saddle, fasten it firmly, and then tighten the string at the tuning machine. After tuning, check the angle of the tremolo unit, and fasten the string stopper bolt of the locking nut to finish the procedure.

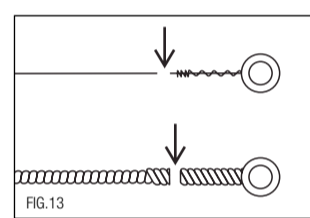
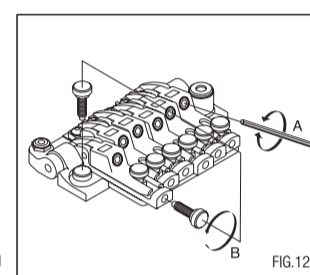

ADJUSTING THE ZERO POINT SYSTEM

The Zero Point system makes it easier to tune a floating tremolo unit, provides greater tuning stability after arming, and limits the tuning drift that would otherwise occur when a string breaks. *If the Zero Point system is not adjusted to the correct position it will not function optimally, since it will either be completely floating, or the Zero Point system and the string tension will be in balance. You must perform this adjustment accurately.

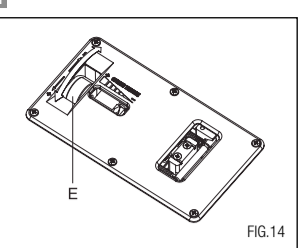

<NOTE>

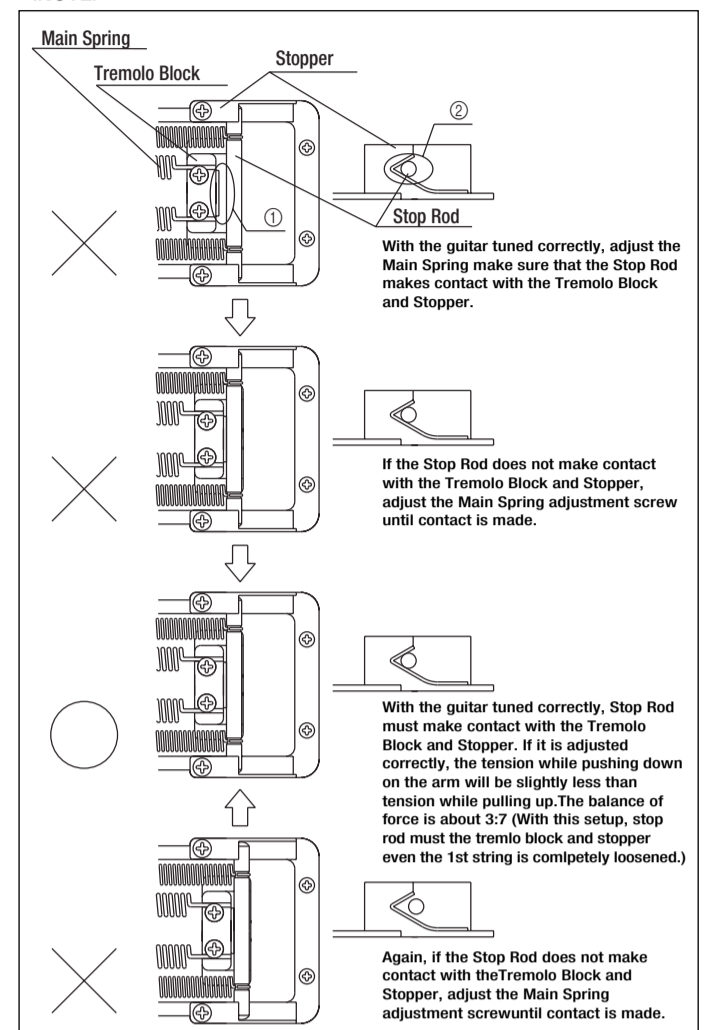

<Note> When a string breaks, because of the tension of neck, the tuning of other strings will be a little higher but still limits within acceptable range.

SWITCHING TO FLOATING OPERATION

By stopping the Zero Point system from functioning, you can make the tremolo float completely. While holding the arm up, remove the stop rod and sub spring. With the guitar tuned correctly, use the main spring adjustment knob (Fig. 14E) to adjust the angle of the tremolo unit. If the tremolo unit is tilted forward toward the neck, turn the spring adjustment knob in the plus (+) direction. Conversely, if the tremolo unit is tilted backward away from the neck, turn the spring adjustment knob in the minus (-) direction. *You will need to tune repeatedly during the process of adjusting the tremolo angle in the floating state, since the tuning will drift each time you adjust the main spring adjustment knob.

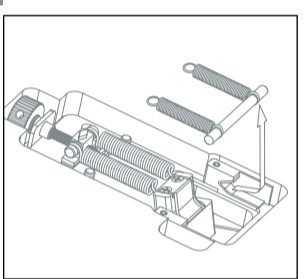

EDGE III TREMOLO

TREMOLO ARM INSTALLATION

The tremolo arm can be inserted and removed very easily. Insert the arm into the armhole on the tremolo base plate. Pull up on the arm to remove it.

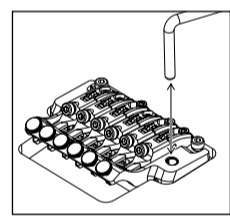

ARM ROTATION TORQUE

The rotation torque of the arm can be adjusted by raising the tremolo and inserting a 1.5mm Allen wrench in the screw (A) on the tremolo block, turning this screw clockwise will tighten the arm torque and turning the screw counter clockwise will loosen the arm torque.

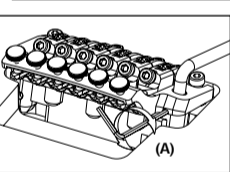

ARM ACTION

The tremolo arm action can be adjusted by using a 3.0mm Allen wrench on the screw (B) of the tremolo screw.

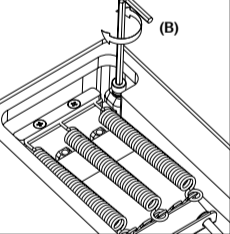

FINE TUNING

Even after locking the locking nut, you can use the fine tuners to make fine adjustments to the tuning of each string. You should adjust all of the fine tuners (C) to the center of adjustable range before you lock the locking nut.

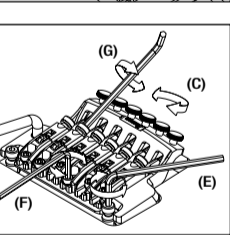

ADJUSTING THE ACTION

To adjust the entire tremolo unit up or down, use an Allen wrench to turn the stud bolt (E) located at the left and right of the tremolo unit. (This cannot be adjusted for each individual string.)

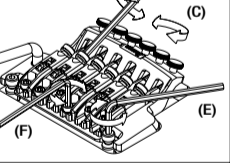

ADJUSTING THE INTONATION

Loosen the Pressure pad screw (D) on the locking nut and loosen the string to be adjusted. Loosen the Saddle lock screws (F) on the saddle to be adjusted and adjust the saddle forward or backward. Tighten the Saddle lock screw (F) and tune the string. After rechecking the intonation, tighten the Pressure pad screw (D).

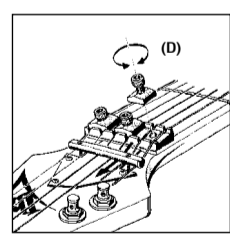

*On the base plate there are two holes for each Saddle lock screw. These allow the user to change string gauges while allowing the maximum saddle movement. If the intonation cannot be adjusted because the saddle needs to be set back further, remove the intonation screw and insert it into the hole located further back on the bridge plate.

REPLACING THE STRINGS

In the case of EDGE III tremolo, replace the strings one by one. Removing all the old strings at once will release the tension on the tremolo and change the tremolo angle "up-pull." Loosen the Pressure pad screw (D) on the locking nut and loosen the string to be replaced. Loosen the String stopper screw (G) and remove the string from the saddle. Cut off the ball end of new string as shown on the illustration and insert the cut side of new string between the saddle and the String holder block. Tighten the String stopper screw (G) and tune the string. After checking the intonation, tighten the Pressure pad screw (D) on the locking nut.

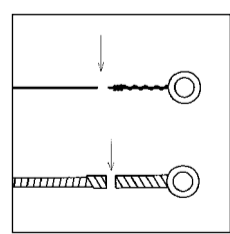

EDGE III ADJUSTING THE TREMOLO SPRING

The tremolo springs adjust the tremolo angle by tightening or loosening the tremolo tension. To adjust tremolo angle, locate the adjustment screws in the rear tremolo cavity. The tremolo system when in tune should sit parallel to the surface of the guitar as follows.

If the tremolo system is not sitting parallel to the surface of the guitar, remove the tremolo cavity cover plate and tighten the Tremolo tension adjustment screws if the tremolo is forward dumped. Loosen the screws if the tremolo is up-pulled. Retune the strings to the proper pitch and check the angle. Choose the number and placement of the tremolo springs according to the string gauge and the tremolo angle.

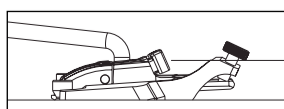
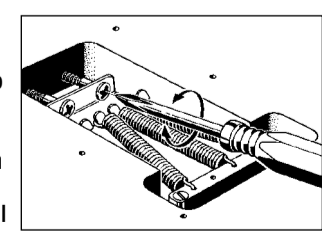

ILT LOCKING TREMOLO

TREMOLO ARM

Insert the tremolo arm into the arm socket and tighten the fingertip tension adjustment wheel. The rotation torque of the arm can be tightened or loosened by adjusting the tremolo arm nut located at the base of the tremolo arm.

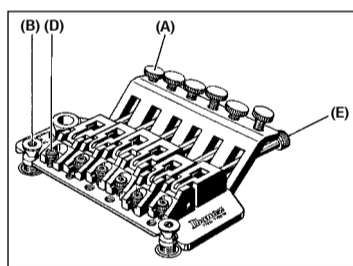

FINE TUNING

After locking the top lock, fine tuning the instrument can be done by turning the fine tuning screws (A).

*To allow maximum fine tuning adjustment, it is recommended that the fine tuners be set to the middle position before locking the nut.

ADJUSTING THE STRING HEIGHT

The height adjustment of the tremolo can be raised or lowered by adjusting the pivot studs (B) that the tremolo mounts on. These are located at either side of the front of the bridge. Clockwise lowers the tremolo and counter clockwise raises the tremolo.

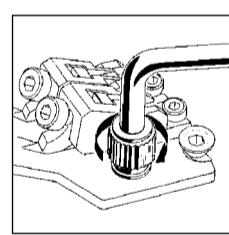

ADJUSTING THE INTONATION

Loosen the Pressure pad screw (C) on the locking nut and loosen the string to be adjusted. Loosen the Saddle lock screws (D) on the saddle to be adjusted and adjust the saddle forward or backward. Tighten the Saddle lock screw (D) and tune the string. After rechecking the intonation, tighten the Pressure pad screw (C).

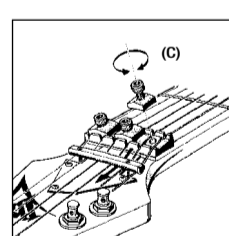

*On the base plate there are two holes for each Saddle lock screw. These allow the user to change string gauges while allowing the maximum saddle movement. If the intonation cannot be adjusted because the saddle needs to be set back further, remove the intonation screw and insert it into the hole located further back on the bridge plate.

REPLACING THE STRINGS

In the case of Lo-TRS II tremolo, replace the strings one by one. Removing all the old strings at once will release the tension on the tremolo and change the tremolo angle "up-pull." Loosen the Pressure pad screw (C) on the locking nut and loosen the string to be replaced. Loosen the String stopper screw (E) and remove the string from the saddle. Cut off the ball end of new string as shown on the illustration and insert the cut side of new string between the saddle and the String holder block. Tighten the String stopper screw (E) and tune the string. After checking the intonation, tighten the Pressure pad screw (C) on the locking nut.

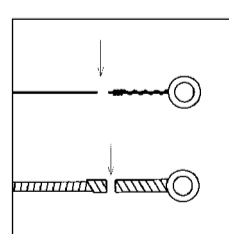

ILT ADJUSTING THE TREMOLO SPRING

The tremolo springs adjust the tremolo angle by tightening or loosening the tremolo tension. To adjust tremolo angle, locate the adjustment screws in the rear tremolo cavity. The tremolo system when in tune should sit parallel to the surface of the guitar as follows.

If the tremolo system is not sitting parallel to the surface of the guitar, remove the tremolo cavity cover plate and tighten the Tremolo tension adjustment screws if the tremolo is forward dumped. Loosen the screws if the tremolo is up-pulled. Retune the strings to the proper pitch and check the angle. Choose the number and placement of the tremolo springs according to the string gauge and the tremolo angle.

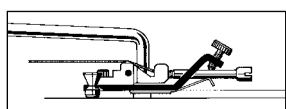
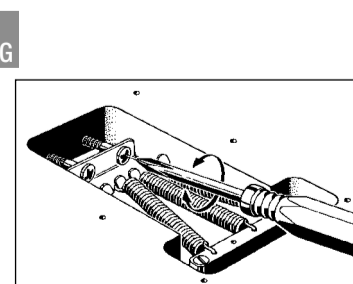

FAT/SAT TREMOLO

TREMOLO ARM INSTALLATION

The tremolo arm can be inserted and removed very easily. Insert the arm into the armhole on the tremolo base plate. Pull up on the arm to remove it.

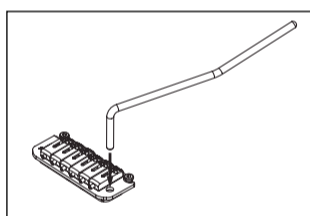

TREMOLO ARM ADJUSTMENT (SAT PRO)

To adjust the height of the arm, remove the tremolo spring cover from the back of the guitar, and use a 3 mm Allen wrench to turn the height adjustment screw attached to the bottom of the tremolo block. Tightening this in the clockwise direction will raise the height.

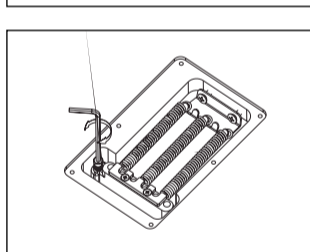

ARM ROTATION TORQUE

The rotation torque of the arm can be adjusted by raising the tremolo and inserting a 1.5mm Allen wrench in the screw (A) on the tremolo block, turning this screw clockwise will tighten the arm torque and turning the screw counter clockwise will loosen the arm torque.

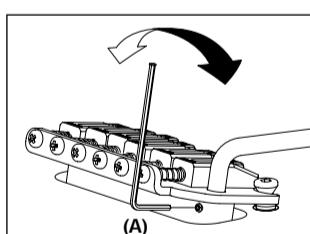

ADJUSTING THE STRING HEIGHT (SAT PRO)

To adjust the action of each string, use a 1.5 mm Allen wrench to turn the screw on the saddle (C). The overall height can be adjusted on either side of the SAT PRO tremolo unit. To adjust the height, use a 3 mm Allen wrench to turn the stud (D) located on either side of the unit. Use caution when adjusting the height of the entire tremolo unit; adjust both sides to the same height to ensure optimum tremolo operation.

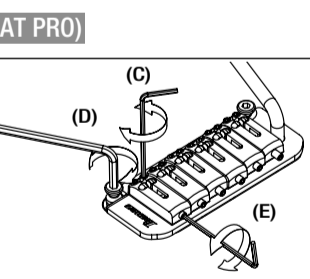

ADJUSTING THE STRING HEIGHT (FAT20/FAT10/SAT10)

The height adjustment of the tremolo can be raised or lowered by adjusting the pivot studs (C) that the tremolo mounts on. These are located at either side of the front of the bridge. Clockwise lowers the tremolo and counter clockwise raises the tremolo.

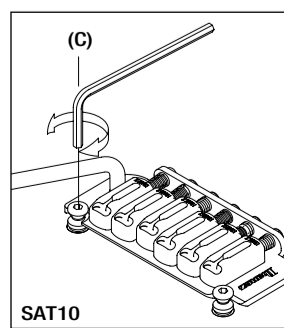
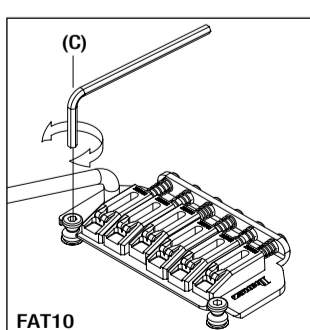
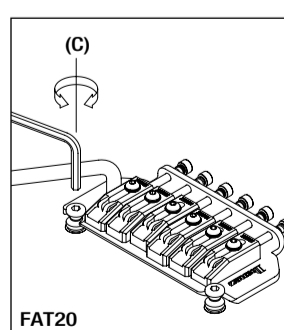

INTONATION ADJUSTMENT (SAT PRO)

To adjust the intonation, use a 1.5 mm Allen wrench to turn the screw located at the rear of the saddle (E). Turn the screw clockwise to move the saddle toward the rear, or counter-clockwise to move the saddle forward.

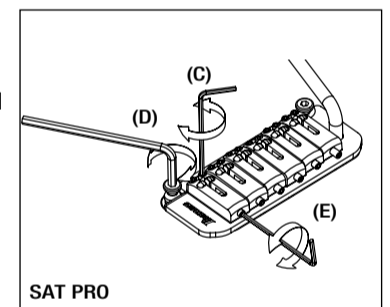

INTONATION ADJUSTMENT (FAT20)

To assure that no movement can occur each saddle has a set screw that locks the saddle. When adjusting the intonation, loosen the saddle lock screw using a 2mm Allen wrench. (D) To adjust the intonation, insert a 2.5mm Allen wrench into the saddle screw at the rear of the tremolo. Turning the wrench clockwise will adjust the saddle backward. Counter clockwise will adjust the saddle forward. After the correct intonation location of the saddle is set tighten the saddle lock down screw to assure no movement will occur. (E)

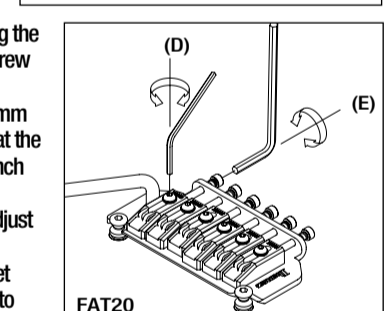

INTONATION ADJUSTMENT (FAT10/SAT10)

The intonation can be adjusted by adjusting the saddle forward or backward using a Phillips (+) head screwdriver on the intonation adjustment screw at the rear of the bridge.

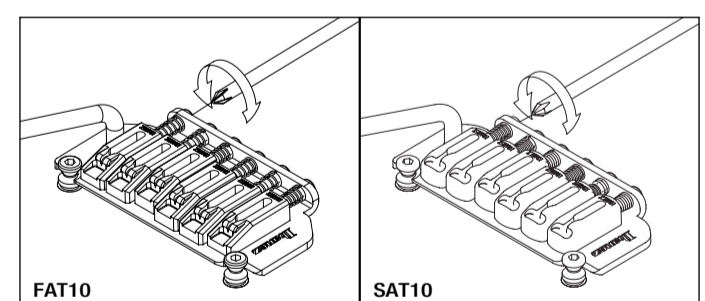

ADJUSTING THE INTONATION & THE STRING HEIGHT (FAT 6)

The intonation can be adjusted by adjusting the saddle forward or backward using a Phillips (+) head adjustment screw at the rear of the bridge. String height is controlled by raising or lowering the small allen screws using a wrench on either side of the saddle.

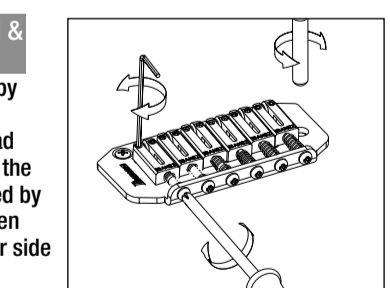

REPLACING THE STRINGS

To replace strings, thread the new strings through the string holes located on the back of the guitar. The strings are then threaded through the tremolo block and up and over the saddle.

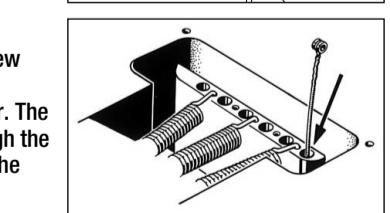

FAT/SAT (expect FAT6)

ADJUSTING THE TREMOLO SPRING

A standard tremolo can be adjusted so that the pitch can be raised when the tremolo arm is pulled up to loosen the tremolo springs located under the tremolo cavity on the back of the guitar. One disadvantage of this procedure is that it can cause the pitch to go sharp if string breaks. To remedy this, adjust the tremolo plate so it sits flush on the body by tightening the tremolo springs. Choose the number and placement of the tremolo springs according to the string gauge and the tremolo adjustment.

