

# RemoteMix C+

## Portable Remote Mixer

### Product Overview

The RemoteMix C+ is a combined audio mixer, headphone amplifier and telephone hybrid in one. It's perfect for remote broadcasts, sporting events, and field reporting from any location.

Simply plug the RemoteMix C+ into an analog phone line, connect a couple of microphones and headphones, and you're ready to call into the station. Switch the "Phone Line" switch to "Dial/Talk" and you will hear a dial tone. Now dial using the RemoteMix C+ keypad. In your headphones, you will hear a mix of both microphones and the line in jack, as well as the audio coming back from the other side of the phone call. This headphone mix also comes out of the back of the unit on an RCA jack and on an XLR balanced jack, which are adjustable from line level to mic level for PA system or tape deck feeds. The built-in time-delayed peak limiter helps to control transmit levels.

You can also connect the RemoteMix C+ to a cellular telephone equipped with a fax/modem interface, which converts your cell phone into the equivalent of a standard RJ-11 phone jack. Just connect the interface between the RemoteMix C+ phone line jack and your cell phone and you are ready to go wireless. Contact your cell phone dealer for fax/modem interface availability.



# JK Audio

Telephone Interface Products

815-786-2929

1-800-JK-Audio

[www.jkaudio.com](http://www.jkaudio.com)

# RemoteMix C+

## Portable Remote Mixer

### Features

**Two XLR Microphone Inputs** with independent level controls. Mic 1 input is mic/line switchable.

**Two 1/4" Headphone Jacks** adjustable with "Headphones" control.

**RCA Line Input** accepts line level signals. Adjustable with the "Line In" control.

**RCA Line Output** delivers a line level signal containing the phone + mic mix. Adjustable to mic level with the "Line Out" control.



**Balanced XLR Output** delivers a line level signal containing the phone + mic mix. Adjustable to mic level with the "Line Out" control.

**RJ-11 Jack** for use with conventional phone lines. Also has an auxiliary handset input for use as a standard telephone. Handset jack is biased for electret microphone types.

**Time Delayed Peak Limiter and VU Meter** help to control transmit levels. The peak limiter has a three second delay before clipping and audio. This allows for normal speech patterns as well as brief exclamations to be broadcast unhindered.

**Two 9 Volt Batteries** will power the unit for 36 hours. The batteries are installed parallel so the unit can run on only one battery if necessary. An AC adapter is also included with the unit.

**DTMF / Pulse Keypad** for dialing out. Tone / Pulse switch located under the battery door.

# JK Audio

Telephone Interface Products

815-786-2929

1-800-JK-Audio

[www.jkaudio.com](http://www.jkaudio.com)

# RemoteMix C+

## Portable Remote Mixer

JK Audio, Inc.  
RemoteMix C+  
Block Diagram  
4/4/00 - WR

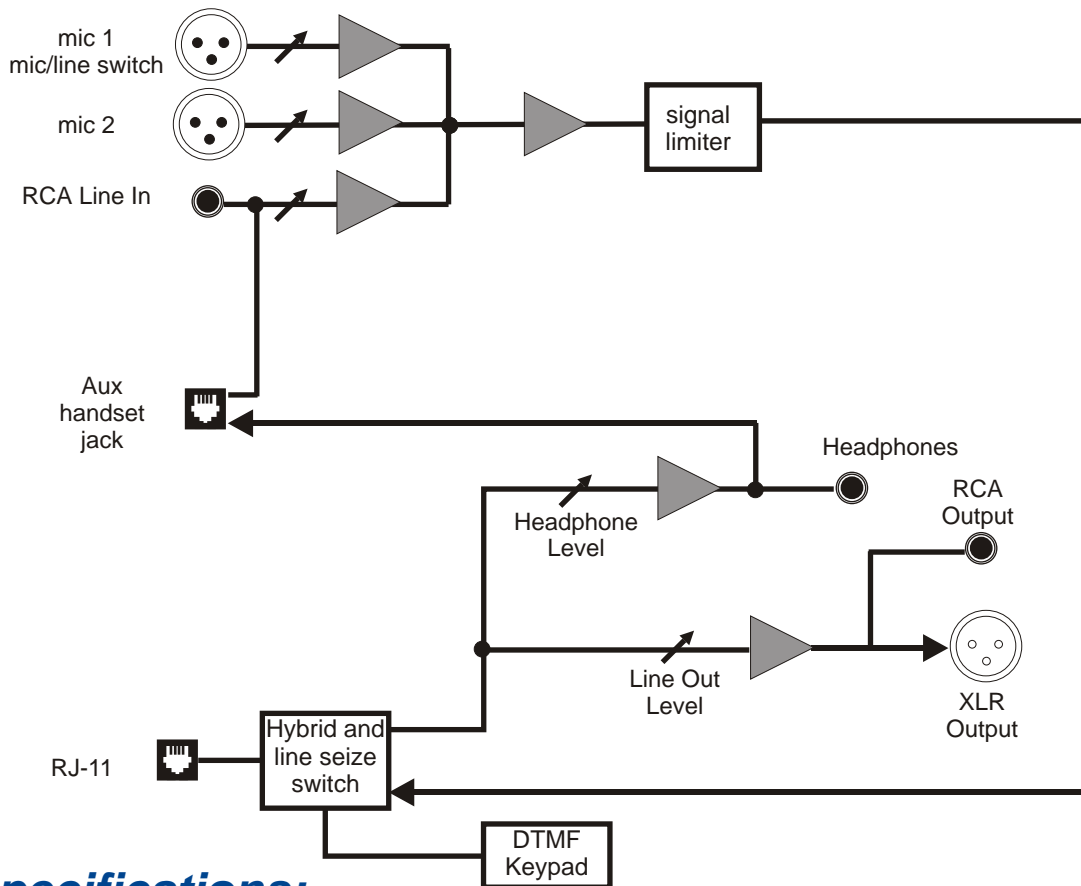

### Specifications:

#### Input

Microphone (2) Female XLR 1 kohm,  
-10 mV RMS (-35 dBm nom.)  
Mic 1 has a Mic/Line switch  
Line= +5 dBm nominal

Line In RCA 20 kohms, 250 mV RMS  
(-10 dBm nom.)

#### Output

Line Out RCA 50 ohms, 250 mV RMS  
(+5 dBm max.)  
Balanced Out Male XLR 200 ohms, 500 mV RMS  
(+12 dBm Max.)  
Headphones (2) 1/4" Stereo 8 ohms  
½ watt per channel

Phone Line Connector RJ11C  
Isolation 1500 VAC  
Ringer 1.2B REN  
Keypad DTMF  
(Dual Tone Multi Frequency)  
/Pulse switchable

Auxiliary Handset Jack, biased for electret  
microphone type handset.

Size: 6.5" x 4.6" x 2.2"  
(16.5 x 11.7 x 5.6cm)

Weight 1.8 pounds

# JK Audio

Telephone Interface Products

815-786-2929

1-800-JK-Audio

[www.jkaudio.com](http://www.jkaudio.com)