

COLORISE

Exa

AnyFi™
Universal Wireless DMX



Blizzard Lighting, LLC
www.blizzardlighting.com
Waukesha, WI USA
Copyright (c) 2015

TABLE OF CONTENTS

Colorise™ EXA	1
1. Getting Started	3
What's In The Box?	3
Getting It Out Of The Box	3
Powering Up!	3
Getting A Hold Of Us	3
Safety Instructions (Don't run with scissors!)	4
2. Meet The Colorise™ EXA LED Par	5
Main Features	5
DMX Quick Reference	5
The Colorise™ EXA Pin-up Picture	6
3. Setup	7
Connecting A Bunch Of Colorise™ EXA Fixtures	7
Data/DMX Cables	7
Setting the DMX Input Connector as the Active DMX Input	7
Cable Connectors	8
3-Pin??? 5-Pin??? Huh?	8
Take It To The Next Level: Setting up DMX Control	8
Fixture Linking (Master/Slave Mode)	9
Mounting/Rigging	9
Using the AnyFi™ Wireless DMX Receiver	10
Setting the Fixture to Receive Wireless Signal	10
Resetting The Wireless	10
Select W-DMX™ or Standard 2.4GHz Receiver	10
Successful W-DMX™ Connections	11
Standard 2.4GHz Mode: Selecting the Channel Group	11
4. Operating Adjustments	12
Navigating The Control Panel	12
Control Panel Menu Structure	13
DMX Mode	14
Set the Starting DMX Address	14
Setting the DMX Channel Mode	14
Slave Mode	14
Dimming Mode Settings	14
LED Display On/Off and Menu Lock	14
Custom Programs	15
Auto, Speed, and Sound Active Modes	15
Color Calibration Settings	16
Custom Static Colors & Preset Colors	16
Fixture Reset Functions	17
Data Sync Feature	17
Fixture Information	17
DMX Value In-Depth Reference Guide	18
DMX In-Depth Reference	19
5. Appendix	20
A Quick DMX Lesson	20
Troubleshooting	20
Keeping Your Colorise™ EXA As Good As New	21
Returns (Gasp!)	21
Shipping Issues	21
Tech Specs	22
Dimensional Drawings	23

1. GETTING STARTED

What's In The Box?

- 1 x Colorise™ EXA Professional LED PAR Fixture
- An Ever-So-Handy Power Cord
- This Lovely User Manual

Getting It Out Of The Box

Congratulations on the purchase of your new totally sweet Colorise™ EXA LED par fixture. She's a real stunner alright, definitely the cat's pajamas! Now that you've got your Colorise™ EXA (or hopefully, *Colorises!*), you should carefully unpack the box and check the contents to ensure that all parts are present and in good condition. If anything looks as if it has been damaged in transit, notify the shipper immediately and keep the packing material for inspection. Again, please save the carton and all packing materials. If a fixture must be returned to the factory, it is important that the fixture be returned in the original factory box and packing.

Powering Up!

All fixtures must be powered directly off a switched circuit and **cannot be run off a rheostat (variable resistor) or dimmer circuit, even if the rheostat or dimmer channel is used solely for a 0% to 100% switch.**

AC Voltage Switch - Not all fixtures have a voltage select switch, so please verify that the fixture you receive is suitable for your local power supply. See the label on the fixture or refer to the fixture's specifications chart for more information. A fixture's listed current rating is its average current draw under normal conditions. Check the fixture or device carefully to make sure that if a voltage selection switch exists that it is set to the correct line voltage you will use.

Warning! Verify that the voltage select switch on your unit matches the line voltage applied. Damage to your fixture may result if the line voltage applied does not match the voltage indicated on the voltage selector switch. All fixtures must be connected to circuits with a suitable Ground (Earthing).

Getting A Hold Of Us

If something is wrong, just give us a call. We'll be happy to help, honest.

Blizzard Lighting
N16 W23390 Stoneridge Dr. Ste E
Waukesha, WI 53188 USA
www.blizzardlighting.com
414-395-8365

Disclaimer: The information and specifications contained in this document are subject to change without notice. Blizzard Lighting™ assumes no responsibility or liability for any errors or omissions that may appear in this user manual. Blizzard Lighting™ reserves the right to update the existing document or to create a new document to correct any errors or omissions at any time. You can download the latest version of this document from www.blizzardlighting.com.

Author:	Date:	Last Edited:	Date:
J. Thomas	8/20/2015	J. Thomas	8/26/2015

SAFETY INSTRUCTIONS



Please read these instructions carefully. They include important information about the installation, usage and maintenance of this product.

- Please keep this User Guide for future use. If you sell the unit to someone else, be sure that they also receive this User Guide.
- ALWAYS make sure that you are connecting to the proper voltage, and that the line voltage you are connecting to is not higher than that stated on the decal or rear panel of the fixture.
- This product is intended for indoor use only.
- To prevent risk of fire or shock, do not expose fixture to rain or moisture.
- Make sure there are no flammable materials close to the unit while operating.
- The unit must be installed in a location with adequate ventilation, at least 20in (50cm) from adjacent surfaces. Be sure that no ventilation slots are blocked.
- ALWAYS disconnect from the power source before servicing or replacing fuse and be sure to replace with same fuse size and type.
- ALWAYS secure fixture using a safety chain. NEVER carry the fixture by its cord. Use its carrying handles.
- DO NOT operate at ambient temperatures higher than 104°F (40°C).
- In the event of a serious operating problem, stop using the unit immediately. NEVER try to repair the unit by yourself. Repairs carried out by unskilled people can lead to damage or malfunction. Please contact the nearest authorized technical assistance center. Always use the same type spare parts.
- NEVER connect the device to a dimmer pack.
- Make sure the power cord is never crimped or damaged.
- Never disconnect the power cord by pulling or tugging on the cord.
- Avoid direct eye exposure to the light source while it is on.

Caution! There are no user serviceable parts inside this unit. Do not open the housing or attempt any repairs yourself. In the unlikely event your unit may require service, please visit <http://www.blizzardlighting.com/support>.

2. MEET THE COLORISE™ EXA LED PAR

MAIN FEATURES

- 12x 15W 6-in-1 RGBAW+UV LEDs, 100,000 hours
- Built-in AnyFi™ wireless DMX receiver (2.4GHz or W-DMX™)
- Natural convection cooled, totally silent operation
- User selectable 32-bit dimming curves
- Variable electronic dimmer strobe
- Built-in color & chase macros via DMX
- Built-in auto programs & sound active in standalone and M/S
- Color mixing ability in standalone mode
- 25 degree beam angle
- User selectable 4/5/6/7/9 or 12-channel DMX modes
- Flicker-free constant-current LED driver
- LED control panel with 4* touch sensitive buttons
- 3-pin male input and 3-pin female output
- PowerCon™ compatible AC power In/Out connectors

DMX Quick Reference - 12/9/7-Channel Modes

Channel	12-Channel	9-Channel	7-Channel
1	Dimmer	Dimmer	Dimmer
2	Red Intensity	Red Intensity	Red Intensity
3	Green Intensity	Green Intensity	Green Intensity
4	Blue Intensity	Blue Intensity	Blue Intensity
5	Amber Intensity	Amber Intensity	Amber Intensity
6	White Intensity	White Intensity	White Intensity
7	UV Intensity	UV Intensity	UV Intensity
8	Strobe	Strobe	---
9	Custom Colors + Auto	32-bit Dimming	---
10	Auto Speed	---	---
11	Virtual Color Wheel	---	---
12	32-bit Dimming	---	---

DMX Quick Reference - 6/5/4-Channel Modes

Channel	6-Channel	5-Channel	4-Channel
1	Red Intensity	Dimmer	Red Intensity
2	Green Intensity	Amber Intensity	Green Intensity
3	Blue Intensity	White Intensity	Blue Intensity
4	Amber Intensity	UV Intensity	White Intensity
5	White Intensity	Virtual Color Wheel	---
6	UV Intensity	---	---

Figure 1: The Colorise™ EXA Pin-Up Picture



Figure 2: The Rear Connections

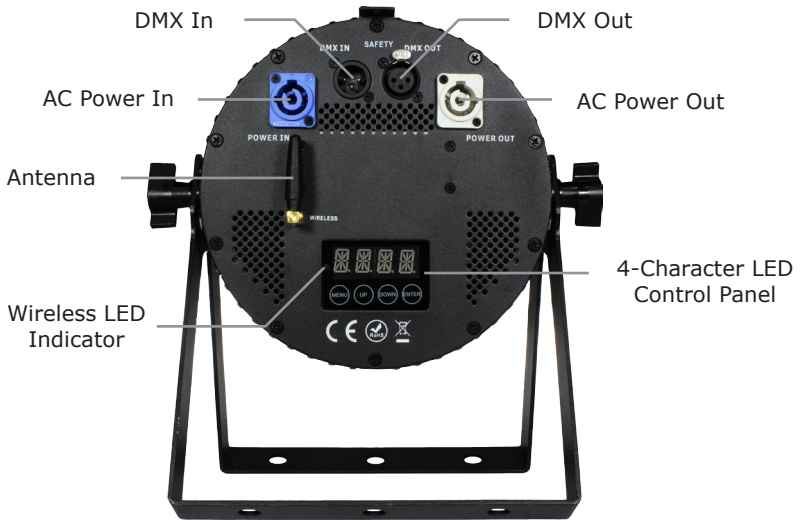

3. SETUP



Before replacing a fuse, disconnect power cord. ALWAYS replace with the same type and rating of fuse.

Fuse Replacement

CAUTION! The Colorise™ EXA utilizes a high-output switch-mode power supply with an internal fuse. Under normal operating conditions, the fuse should not require replacement. The fuse is field replaceable, however it is an advanced procedure suited to qualified individuals. Should your fixture require replacement, please contact Blizzard Lighting for instructions, or to return your unit for service.

Connecting A Bunch of Colorise™ EXA Fixtures

You will need a serial data link to run light shows using a DMX-512 controller or to run shows on two or more fixtures set to sync in master/slave operating mode. The combined number of channels required by all the fixtures on a serial data link determines the number of fixtures the data link can support.

Fixtures on a serial data link must be daisy chained in one single line. Also, connecting more than 32 fixtures on one serial data link without the use of a DMX optically-isolated splitter may result in deterioration of the digital DMX signal. The maximum recommended cable-run distance is 500 meters (1640 ft). The maximum recommended number of fixtures on a serial data link is 32 fixtures.

Data/DMX Cabling

To link fixtures together you'll need data cables. You should use data-grade cables that can carry a high quality signal and are less prone to electromagnetic interference.

For instance, Belden© 9841 meets the specifications for EIA RS-485 applications. Standard microphone cables will "probably" be OK, but note that they cannot transmit DMX data as reliably over long distances. In any event, the cable should have the following characteristics:

*2-conductor twisted pair plus a shield
Maximum capacitance between conductors – 30 pF/ft.
Maximum capacitance between conductor & shield – 55 pF/ft.
Maximum resistance of 20 ohms / 1000 ft.
Nominal impedance 100 – 140 ohms*

Setting the DMX Input Connector as the Active DMX Input

Navigate the main menu to reach **SET**, press **<ENTER>**, then use the **<UP/DOWN>** buttons until **SIGN** is displayed, then press **<ENTER>** again. Now use the **<UP/DOWN>** buttons to highlight **CABL** (cable mode), and press **<ENTER>** to confirm.

Cable Connectors

Cables must have a male XLR connector on one end and a female XLR connector on the other end. (Duh!)

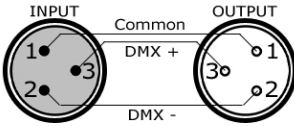

A Word on Termination: DMX is a resilient communication protocol, however errors still occasionally occur. Termination reduces signal errors, and therefore best practices include use of a terminator in all circumstances. If you are experiencing problems with erratic fixture behavior, especially over long signal cable runs, a terminator may help improve performance.

To build your own DMX Terminator:
Obtain a 120-ohm, 1/4-watt resistor, and wire it between pins 2 & 3 of the last fixture. They are also readily available from specialty retailers.

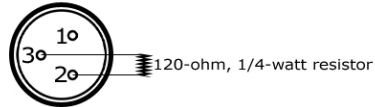

CAUTION: Do not allow contact between the common and the fixture's chassis ground. Grounding the common can cause a ground loop, and your fixture may perform erratically. Test cables with an ohm meter to verify correct polarity and to make sure the pins are not grounded or shorted to the shield or each other.

3-Pin??? 5-Pin??? Huh?!?

If you use a controller with a 5 pin DMX output connector, you will need to use a 5 pin to 3 pin adapter. They are widely available over the internet and from specialty retailers. If you'd like to build your own, the chart below details a proper cable conversion:

Conductor	3-Pin Female (Output)	5-Pin Male (Input)
Ground/Shield	Pin 1	Pin 1
DMX Data (-)	Pin 2	Pin 2
DMX Data (+)	Pin 3	Pin 3
Not Used.	No Connection.	No Connection.
Not Used.	No Connection.	No Connection.

Take It To The Next Level: Setting Up DMX Control

Step 1: Connect the male connector of the DMX cable to the female connector (output) on the controller.

Step 2: Connect the female connector of the DMX cable to the first fixture's male connector (input). *Note:* It doesn't matter which fixture address is the first one connected. We recommend connecting the fixtures in terms of their proximity to the controller, rather than connecting the lowest fixture number first, and so on.

Step 3: Connect other fixtures in the chain from output to input as above. Place a DMX terminator on the output of the final fixture to ensure best communication.

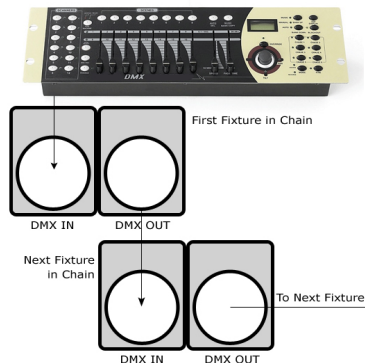

Fixture Linking (Master/Slave Mode)

1. Connect the (male) 3 pin connector side of the DMX cable to the output (female) 3 pin connector of the first fixture.
2. Connect the end of the cable coming from the first fixture which will have a (female) 3 pin connector to the input connector of the next fixture consisting of a (male) 3 pin connector. Then, proceed to connect from the output as stated above to the input of the following fixture and so on.

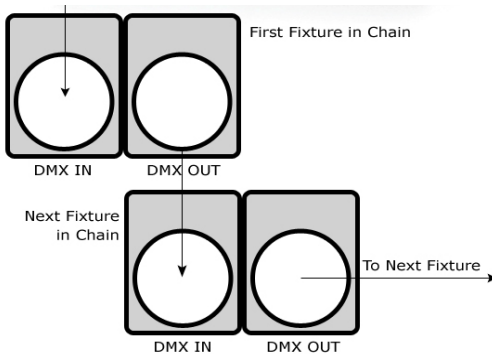

A quick note: Often, the setup for Master-Slave and Standalone operation requires that the first fixture in the chain be initialized for this purpose via either settings in the control panel or DIP-switches. Secondly, the fixtures that follow may also require a slave setting.

Check the **“Operating Adjustments”** section in this manual for complete instructions for this type of setup and configuration.

Mounting & Rigging

This fixture may be mounted in any SAFE position provided there is enough room for ventilation.

It is important never to obstruct the fan or vents pathway. Mount the fixture using a suitable “C” or “O” type clamp. The clamp should be rated to hold at least 10x the fixture’s weight to ensure structural stability. Do not mount to surfaces with unknown strength, and ensure properly “rated” rigging is used when mounting fixtures overhead.

Adjust the angle of the fixture by loosening both knobs and tilting the fixture. After finding the desired position, retighten both knobs.

- When selecting installation location, take into consideration lamp replacement access (if applicable) and routine maintenance.
- Safety cables **MUST ALWAYS** be used.
- Never mount in places where the fixture will be exposed to rain, high humidity, extreme temperature changes or restricted ventilation.

Using the AnyFi™ Wireless DMX Receiver

In addition to the unbridled thrill you already received the first time you turned on your fixture, you'll be delighted to know that your Colorise™ EXA is equipped to work seamlessly with our own Skywire™ 2.4GHz wireless DMX products, as well as W-DMX™ wireless products. W-DMX™ is a two-time award winning wireless DMX technology, created and owned by Wireless Solution Sweden AB.



Skywire™ wireless DMX products feature 512 auto-assigning frequencies in 7 groups allowing up to 7 systems to run simultaneously in the same space, completely free of interference, with reliable wireless communication for over 1000 feet line-of-sight! Using W-DMX™ wireless, you can expect an outstanding wireless range of up to 500 meters (line-of-sight), very easy setup, and leave any worries behind concerning loss of signal due to its built-in FHSS technology (Frequency Hopping Spread Spectrum).

So first, if you would like to use Standard 2.4GHz wireless DMX, you will need a Blizzard wiCICLE® transmitter, Lightcaster™ transceiver, or any Blizzard Lighting controller that has this type of built-in wireless transmitter, like our Kontrol 6 Skywire™ to act as a transmitter. And if you plan on using W-DMX™ 2.4GHz wireless for your setup, you will need a W-DMX™ transceiver to broadcast the signal from your controller, such as our Lightcaster W-DMX™.

Ready to move on? Well alrighty!

1.) **IMPORTANT** - Set the Fixture to Receive Wireless Signal in the Control Panel

a.) Navigate the main menu to reach **SET**, press **<ENTER>**, then use the **<UP/DOWN>** buttons until **SIGN** is displayed, then press **<ENTER>** again. Now use the **<UP/DOWN>** buttons to highlight **2.4G** (wireless mode), and press **<ENTER>** to confirm.

2.) Resetting The Wireless

a.) Navigate the main menu to reach **SET**, press **<ENTER>**, then use the **<UP/DOWN>** buttons until **WIRE** is displayed, then press **<ENTER>** again.
b.) From here, you can use the **<UP/DOWN>** buttons to highlight **REST** and press **<ENTER>**, select **YES**, then **<ENTER>** to reset the wireless setup.

3.) Select W-DMX™ or Standard 2.4GHz Receiver

a.) Make sure the device you are using to transmit signal with is powered on.
b.) Navigate the main menu to reach **SET**, press **<ENTER>**, then use the **<UP/DOWN>** buttons until **WIRE** is displayed, then press **<ENTER>** again.
c.) Now use the **<UP/DOWN>** buttons to highlight **KEY** in the menu, and press **<ENTER>**.
d.) At this point, please note that every time you touch the **<ENTER>** button, the wireless LED status indicator changes between 4 colors (**but only 2 are functional**):

- **GREEN:** W-DMX™ 2.4 GHz Mode
- **YELLOW:** Standard 2.4 GHz Mode (wiCICLE™ & LightCaster Compatible)

Note: **RED and **BLUE** currently have no function during this selection process.*

e.) While the LED indicator is illuminated in **GREEN** (for W-DMX) or **YELLOW** (for Standard 2.4GHz), press and hold the **<ENTER>** button for **3 seconds** to make your chosen wireless type the active wireless DMX signal type.

For W-DMX™ connections, you should be done. The fixture will detect the signal!

For Standard 2.4GHz connections, please continue to **Step 5 on the next page.*

4.) Successful W-DMX™ Connections

The LED status indicator will blink, then turn white if searching for a signal. When a signal connection is established, the LED on the fixture will be solid **GREEN**, if signal is lost the LED will flash **RED**.

W-DMX™ Setup Examples:

1.) One transceiver with multiple receiver setups:

- a.) Power on all units.
- b.) On the receiving W-DMX fixtures, follow the previous instructions to pair them with the transmitting unit.

2.) Multiple transceiver setups, with multiple receivers; e.g. 3 groups consisting of a transceiver & receiver(s) named A, B, and C:

- a.) Turn power off of all units.
- b.) Group "A" gets powered on, then follow step 1 above.
- c.) Group "B" gets powered on, then follow step 1 above.
- d.) Group "C" gets powered on, then follow step 1 above.

5.) Standard 2.4GHz Mode: Selecting the Channel Group

1. After selecting Standard 2.4GHz Mode in **Step 3** on the previous page, the fixture is ready and waiting for your input to select the frequency group to match that of your transmitting source.

a.) Tap the **<ENTER>** button repeatedly to scroll through the 7 color group frequencies:

- GROUP 1: **RED**
- GROUP 2: **GREEN**
- GROUP 3: **YELLOW**
- GROUP 4: **BLUE**
- GROUP 5: **VIOLET**
- GROUP 6: **CYAN**
- GROUP 7: **WHITE**

NOTE: "GROUP" number also corresponds to the "GROUP" setting on our LightCaster™ wireless DMX transceiver, wiCICLE™ transmitter, and all Blizzard Skywire™ wireless controllers.

b.) While your chosen group number/color is illuminated on the status LED, press and hold the **<ENTER>** button for 3 seconds.

2. The LED on the transmitter will blink **RED** slowly until communication is established with the receiver. The status LED on the receiving fixtures will be illuminated in the color of the group that it is set on until communication is established.

3. Once the clearest channel is auto-selected, the status LEDs will blink quickly on both the transmitter and receiver. NOTE: The color of the status LED DURING operation does not indicate channel group, instead it indicates whether the unit is transmitting or receiving.
That's It!

4. OPERATING ADJUSTMENTS

The Control Panel

All the goodies and different modes possible with the Colorise™EXA are accessed by using the control panel on the rear of the fixture. There are 4 control buttons below the LED display which allow you to navigate through the various control panel menus.

<MENU>

Is used to navigate to the previous higher-level menu item.

<UP>

Scrolls through menu items and numbers in ascending order.

<DOWN>

Scrolls through menu items and numbers in descending order.

<ENTER>

Is used to select and confirm/store the current selection.

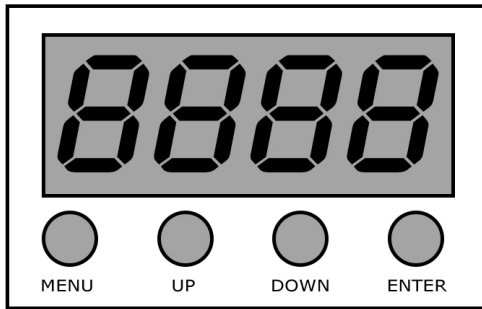

The control panel LED display shows the menu items you select from the menu map on page #13. When a menu function is selected, the display will show immediately the first available option for the selected menu function. To select a menu item, press **<ENTER>**.

Use the **<UP>** and **<DOWN>** buttons to navigate the menu options. Press the **<ENTER>** button to select the menu function currently displayed, or to enable a menu option. To return to the previous option or menu without changing the value, press the **<MENU>** button.

Control Panel Menu Structure

ADDR	001-512	To choose the DMX address		
STAT	R	Red intensity (0% <--> 100%)		
	G	Green intensity (0% <--> 100%)		
	B	Blue intensity (0% <--> 100%)		
	A	Amber intensity (0% <--> 100%)		
	W	White intensity (0% <--> 100%)		
	UV	UV intensity (0% <--> 100%)		
	SHUT	Flash / strobe speed (0-255)		
	PRSC (preset colors)	NONE, R, G, B, A, W, UV, YELLOW, PINK, CYAN, ORANGE, VIOLET, GOLDEN, 2700K, 3200K, 4000K, 5500K, 6500K, RGBW		
SET	CAL	To set global intensity levels of each color + USE: YES/NO		
	CHMD	12CH	To run in 12-channel mode	
		9CH	To run in 9-channel mode	
		7CH	To run in 7-channel mode	
		6CH	To run in 6-channel mode	
		5CH	To run in 5-channel mode	
		4CH	To run in 4-channel mode	
	DIM (dimming)	LIN	Linear dimming curve	
		SQR	Square law curve	
		ISQR	Inverse square law curve	
		SCUR	S-curve	
		LIN.	Linear dimming curve (smooth)	
		SQR.	Square law curve (smooth)	
		ISQR.	Inverse square law curve (smooth)	
		SCUR.	S-curve (smooth)	
	DISY	ON	LED menu display is on continually	
		2MIN	LED menu display shuts off after 2 minutes of inactivity	
LOCK	YES/NO	Menu locks after 2min. Hold any key 10 seconds to unlock.		
SIGN	<ENTER>	Choose the signal type: 2.4G (wireless) or CABL (cable)		
WIRE	<ENTER>	Wireless Reset: REST, or KEY desired wireless mode (color coded LED)		
CTST	CT01-CT10	<ENTER>	R/G/B/A/W/UV adjustments for custom color banks 01-10	
AUTO	AT01-AT05	<ENTER>	Auto programs 1-5	
	ATSP	<ENTER>	Auto Speed	
	CHS1	<ENTER>	Custom program 1	
	CHS2	<ENTER>	Custom program 2	
	CHS3	<ENTER>	Custom program 3	
	SOU1	<ENTER>	Sound Active Mode 1 (color changing)	
	SOU2	<ENTER>	Sound Active Mode 2 (white strobe)	
PROG	CHS1-CHS3 Custom programs 1-3.	SC01-SC20 20 scenes for each custom program.	R (0-255)	SHUT (strobe, 0-255)
			G (0-255)	AUTO (None, AT01-AT05)
			B (0-255)	ATSP (speed, 0-255)
			A (0-255)	TIME (duration, 0-255)
			W(0-255)	WAIT (before fade, 0-255)
				USE (use scene, YES/NO)
INFO	SOFT	Vx.x	Software version information	
		POW	Current automated overheat protection level (100%/80%/50%)	
LOAD	ST L		Restore factory settings	
	PR L		Restore factory program settings	
SEND	YES/NO		Sync settings between fixtures via DMX	

DMX Mode

Allows the unit to be controlled by any universal DMX controller.

Setting the DMX Address:

- 1.) The default mode for the fixture is DMX, which appears as **001** on the LED readout. To select a different DMX address, using the **<MENU>** button, select **ADDR**, then hit **<ENTER>**. Use the **<UP/DOWN>** buttons to select the correct address, then hit **<ENTER>** to confirm.

Setting the DMX Channel Mode:

- 1.) To select a DMX channel mode, press the **<MENU>** button, then use the **<UP/DOWN>** buttons until the display reads **SET** and press the **<ENTER>** button. Then use the **<UP/DOWN>** buttons until the display reaches **CHMD**, and press **<ENTER>**. Now press the **<UP/DOWN>** buttons again to highlight your desired DMX channel mode, and press the **<ENTER>** button to confirm.

Slave Mode:

- 1.) Daisy chain the fixtures DMX in/out, having the controller at the beginning of the line.
- 2.) There is nothing else to it! The first fixture in the DMX chain is the master fixture, and the following fixtures will follow the master.

Dimming Mode Settings:

Allows users to set the fixture to use 1 of 4 (x2) dimming curve settings for smoother (and slower) dimming capabilities. In the control panel menu, there are two settings for each curve that are distinguishable from one another by the trailing dot.

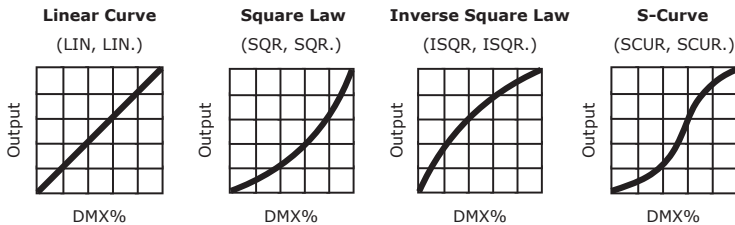

*The curve settings with the trailing dot adds a bit more delay to the curve for a smoother effect.

- 1.) Use the **<MENU>** and **<UP/DOWN>** buttons to navigate to **SET** and press **<ENTER>**, then **<UP/DOWN>** buttons again to scroll to **DIM**, and press the **<ENTER>** button.
- 2.) Now use the **<UP/DOWN>** buttons to highlight either **LIN** (Linear), **SQR** (Square), **ISQR** (Inverse Square), **SCUR** (S-Curve), **LIN.** (Smooth Linear), **SQR.** (Smooth Square), **ISQR.** (Smooth Inverse Square), or **SCUR.** (Smooth S-Curve), then hit **<ENTER>**.

LED Display On/Off and Menu Lock:

- 1.) Use the **<MENU>** and **<UP/DOWN>** buttons to navigate to **SET** and press **<ENTER>**, then navigate to **DISY**, and press the **<ENTER>** button.
- 2.) In **DISY**, you can set the LED menu display to be continually on, or shut off after 2 minutes of inactivity. In **LOCK** which is in the main (top) menu, you can select either **YES** or **NO**, and press **<ENTER>** to save. Enabling key lock will disable the functionality of the buttons after 2 minutes. To exit this locked setting, press and hold any button for 10 seconds.

Custom Programs:

Allows users to create up to 3 customizable, 20 scene programs that are directly accessible via the control panel and also in DMX mode.

Creating A Custom Program:

- 1.) Use the **<MENU>** and **<UP/DOWN>** buttons to navigate to **PROG**, and press **<ENTER>**.
- 2.) Now use the **<UP/DOWN>** buttons to highlight your choice of either **CHS1**, **CHS2**, or **CHS3** and press **<ENTER>**.
- 3.) Start with editing scene 1 (**SC01**), customizing it to your liking by using the choices outlined in the table below. You can insert any of its 5 built-in auto programs (**AT01-AT05**), and adjust its speed (**ATSP 0-255**), and also set the duration (in seconds) before moving on to the next scene (**TIME 0-255**). You can also add a fade in effect to the start of this scene (**WAIT 0-255**), and/or strobe (**SHUT 0-255**). Finally, if you want to use this scene in your program, *be sure to enable it (USE: YES/NO)*.
- 4.) Repeat the above process to create up to 20 scenes in each of the 3 customizable programs.

R (0-255) - Red Intensity	UV (0-255) - UV Intensity	WAIT (0-255) - Fade In (fast - slow)
G (0-255) - Green Intensity	SHUT (0-255) - Strobe (slow - fast)	USE (YES/NO) Use Scene in Program?
B (0-255) - Blue Intensity	AUTO (AT01-AT05) - Auto Programs	IMPORTANT: <i>If USE is set to NO, or TIME is set to 0, the scene will not run!</i>
A (0-255) - Amber Intensity	ATSP (0-255) - Auto Speed (fast - slow)	
W (0-255) - White Intensity	TIME (0-255) - Scene Time (seconds)	

Running A Custom Program:

- 1.) To view your newly created lighting masterpiece, use the **<MENU>** and **<UP/DOWN>** buttons to navigate to **AUTO**, and press **<ENTER>**.
- 2.) Use the **<UP/DOWN>** buttons to highlight your choice of either **CHS1**, **CHS2**, or **CHS3** and press **<ENTER>**. These are also directly accessible from the **Effect Channel** in DMX mode.

Auto, Speed, and Sound Active Modes:

Set single or Master/Slaved units to run in sound active or auto mode at user selectable speeds.

Sound Active Mode:

- 1.) Use the **<MENU>** and **<UP/DOWN>** buttons to navigate to **AUTO** and press **<ENTER>**, then with the **<UP/DOWN>** buttons navigate to **SOU1** (color change), or **SOU2** (white strobe only), and press the **<ENTER>** button.

Auto Mode:

- 1.) Use the **<MENU>** and **<UP/DOWN>** buttons to navigate to navigate to **AUTO**, and press the **<ENTER>** button.
- 2.) Now use the **<UP/DOWN>** buttons to highlight any program ranging from **AT01-AT05**, and press **<ENTER>**.

Auto Speed:

- 1.) Use the **<MENU>** and **<UP/DOWN>** buttons to navigate to **AUTO** and press **<ENTER>**, then with the **<UP/DOWN>** buttons navigate to **ATSP**, and press the **<ENTER>** button.
- 2.) Make a selection from **0-255**, and press **<ENTER>** to choose a speed (slow <-> fast).

Color Calibration Settings:

Allows the user to setup and save 1 customized R/G/B/A/W/UV color balance setting and save it for future use. This custom setting is global, and it will effect all modes.

- 1.) Use the **<MENU>** and **<UP/DOWN>** buttons to navigate to **SET** and press **<ENTER>**, then on while **CAL**, push **<ENTER>** again.
- 2.) Use the **<UP/DOWN>** buttons to highlight either **R** (Red Level), **G** (Green Level), **B** (Blue Level), **A** (Amber Level), **W** (White Level), or **UV** (UV Level), then hit **<ENTER>**.
- 3.) Now using the **<UP/DOWN>** buttons, select the maximum level for each color between 000-255 (000=off), and hit **<ENTER>** to confirm your choice.
- 4.) You have now just setup and saved a custom global color calibration setting that you can use at you convenience. To use your custom setting now (or later), press the **<UP/DOWN>** buttons to reach **USE**, and press **<ENTER>**. Then choose either **YES** or **NO** and press **<ENTER>**. When you select **YES**, it enables this custom color calibration globally, and when choosing **NO** the fixture will continue to use the default color calibration settings. Your customized settings will be saved for later use even after powering off the fixture. It can be altered to your liking at any time. Just remember to return to this setting to either enable or disable it when needed.

Custom Static Colors & Preset Colors:

Allows the user to create and save up to 10 custom static colors for use in standalone or DMX mode.

Custom Mixing and Preset Mixed Colors

- 1.) Use the **<MENU>** and **<UP/DOWN>** buttons to navigate to **STAT** and press **<ENTER>**, then **<UP/DOWN>** buttons to select R/G/B/A/W/UV, and push **<ENTER>** to confirm your selection. Then in the same manner, you can select **SHUT** to add s strobe effect.
- 2.) You can also select **<PRSC>** and use the **<UP/DOWN>** buttons to scroll through and quickly use any of the fixtures built-in preset colors.

Mix and Save Custom Colors (1-10)

- 1.) Use the **<MENU>** and **<UP/DOWN>** buttons to navigate to **CTST** and press **<ENTER>**, then **<UP/DOWN>** buttons to select a color bank from **CT01-CT10**, and push **<ENTER>** to confirm your selection.
- 2.) Now use the **<UP/DOWN>** buttons to highlight either **R** (Red Level), **G** (Green Level), **B** (Blue Level), **A** (Amber Level), **W** (White Level), or **UV** (UV Level), then hit **<ENTER>**.
- 3.) Finally, using the **<UP/DOWN>** buttons, select the maximum level for each color between 000-255 (000=off), and hit **<ENTER>** to confirm your choice(s).
- 4.) These 10 custom colors can be accessed and edited to your liking at any time, and will be saved even after powering off the fixture.
- 5.) Your custom static colors are directly accessible from the **Effect Channel** in DMX mode.

Fixture Reset Functions:

Allows users to reset the fixture to factory default settings, without losing customized settings, or reset the custom programs exclusively.

- 1.) Use the **<MENU>** and **<UP/DOWN>** buttons to navigate to **LOAD** and press **<ENTER>**, then use the **<UP/DOWN>** buttons to highlight **ST L** or **PR L**, and press **<ENTER>**.
- 2.) Use the **<UP/DOWN>** buttons to highlight either **YES** or **NO**, then press **<ENTER>**.
- 3.) The **ST L** reset function will reset all default values *with the exception of* those in **ADDR** (address), **CTST** (10 custom colors), and **PROG** (custom scenes and programs).
- 4.) The **PR L** reset function will only reset all customized program settings found in the **PROG** settings (custom scenes and programs).

Data Sync Feature:

Users can transfer their custom settings from one fixture to another via DMX.

- 1.) Disconnect fixtures from any DMX controllers, and link them together via DMX in/out.
- 2.) On the sending fixture (DMX out), navigate the main menu using the **<UP/DOWN>** buttons to reach **SEND**, and press the **<ENTER>** button.
- 3.) Select **YES**, and press the **<ENTER>** button to begin the transfer.
- 4.) Information for **ADDR** (address), or **CAL** (global intensity) will not be sent.
- 5.) After the data has been transferred, the receiving fixture will be automatically be reset.

Fixture Information:

These are not editable features, they are for informational purposes only.

- 1.) Use the **<MENU>** and **<UP/DOWN>** buttons to navigate to **INFO** and press **<ENTER>**, then use the **<UP/DOWN>** buttons to highlight **SOFT** or **POW**, and press **<ENTER>**.
- 2.) The **SOFT** information simply displays the current software version installed on the fixture, and **POW** displays the fixtures current power level setting. Under normal conditions, it will be at 100%... but this fixture has built-in overheat protection that may automatically reduce the output level to 80%, or 50% in high temperature situations.

DMX Value In-Depth Reference Guide

Function	Value	What It Does
Dimmer	000 <--> 255	(0% <--> 100%)
Red Intensity	000 <--> 255	(0% <--> 100%)
Green Intensity	000 <--> 255	(0% <--> 100%)
Blue Intensity	000 <--> 255	(0% <--> 100%)
Amber Intensity	000 <--> 255	(0% <--> 100%)
White Intensity	000 <--> 255	(0% <--> 100%)
UV Intensity	000 <--> 255	(0% <--> 100%)
Strobe	000 <--> 005 006 <--> 020 021 <--> 060 061 <--> 100 101 <--> 140 141 <--> 180 181 <--> 220 221 <--> 255	No strobe Non-synchronous strobe (slow <--> fast) Synchronous strobe (slow <--> fast) Electronic sine wave (slow <--> fast) Random strobe (slow <--> fast) Opening pulse (slow <--> fast) Closing pulse (slow <--> fast) Electronic square wave (slow <--> fast)
Effect	000 <--> 010 011 <--> 015 016 <--> 020 021 <--> 025 026 <--> 030 031 <--> 035 036 <--> 040 041 <--> 045 046 <--> 050 051 <--> 055 056 <--> 060 061 <--> 065 066 <--> 070 071 <--> 075 076 <--> 080 081 <--> 085 086 <--> 090 091 <--> 095 096 <--> 100 101 <--> 105 106 <--> 110 111 <--> 115 116 <--> 120 121 <--> 125 126 <--> 130 131 <--> 135 136 <--> 140 141 <--> 145 146 <--> 150 151 <--> 155 156 <--> 160 161 <--> 165 166 <--> 170 171 <--> 175 176 <--> 180 181 <--> 185 186 <--> 190 191 <--> 195 196 <--> 200 201 <--> 255	No Function Custom color 1 (CT01 in menu settings) Custom color 2 (CT02 in menu settings) Custom color 3 (CT03 in menu settings) Custom color 4 (CT04 in menu settings) Custom color 5 (CT05 in menu settings) Custom color 6 (CT06 in menu settings) Custom color 7 (CT07 in menu settings) Custom color 8 (CT08 in menu settings) Custom color 9 (CT09 in menu settings) Custom color 10 (CT10 in menu settings) Auto 1 - (R, G, B, A, W, UV, RG, RB, GB, AW, WUV, AUV) Auto 2 - R↑, R↓, G↑, G↓, B↑, B↓, A↑, A↓, W↑, W↓, UV↑, UV↓ Auto 3 - (R↑G↑, R↓G↓, R↑B↑, R↓B↓, B↓G↓, B↑G↑) Auto 4 - RGBW↑, RGBW↓ Auto 5 - B, BG↑, BG, B↓G, G, GR↑, GR, G↓R, R, RB↑, RB, R↓B

DMX Value In-Depth Reference Guide (continued)

Function	Value	What It Does
Speed (Auto 1-5)	000 <--> 255	(fast <--> slow)
Virtual Color Wheel	000 <--> 010 011 012 <--> 050 051 052 <--> 090 091 092 <--> 130 131 132 <--> 170 171 172 <--> 210 211 212 <--> 250 251 <--> 255	No Function Blue Blue (+ green) Teal Teal (- blue) Green Green (+ red) Yellow Yellow (- green) Red Red (+ blue) Magenta Magenta (- red) Blue
Dimming Mode	000 <--> 010 011 <--> 020 021 <--> 030 031 <--> 040 041 <--> 050 051 <--> 060 061 <--> 070 071 <--> 080 081 <--> 090 091 <--> 255	Default (as set in the LED menu) Linear curve Square law curve Inverse square law curve S-curve Linear curve (smooth) Square law curve (smooth) Inverse square law curve (smooth) S-curve (smooth) Default (as set in the LED menu)

DMX In-Depth Reference: 12/9-Channel Modes

12-Channel	Name	9-Channel	Name
1	Dimmer (0%<--> 100%)	1	Dimmer (0%<--> 100%)
2	Red Intensity (0%<--> 100%)	2	Red Intensity (0%<--> 100%)
3	Green Intensity (0%<--> 100%)	3	Green Intensity (0%<--> 100%)
4	Blue Intensity (0%<--> 100%)	4	Blue Intensity (0%<--> 100%)
5	Amber Intensity (0%<--> 100%)	5	Amber Intensity (0%<--> 100%)
6	White Intensity (0%<--> 100%)	6	White Intensity (0%<--> 100%)
7	UV Intensity (0%<--> 100%)	7	UV Intensity (0%<--> 100%)
8	Strobe	8	Strobe
9	Effect	9	32-Bit Dimming
10	Auto Speed (fast <--> slow)	---	---
11	Virtual Color Wheel	---	---
12	32-Bit Dimming		

DMX In-Depth Reference: 7/6-Channel Modes

7-Channel	Name	6-Channel	Name
1	Dimmer (0%<--> 100%)	1	Red Intensity (0%<--> 100%)
2	Red Intensity (0%<--> 100%)	2	Green Intensity (0%<--> 100%)
3	Green Intensity (0%<--> 100%)	3	Blue Intensity (0%<--> 100%)
4	Blue Intensity (0%<--> 100%)	4	Amber Intensity (0%<--> 100%)
5	Amber Intensity (0%<--> 100%)	5	White Intensity (0%<--> 100%)
6	White Intensity (0%<--> 100%)	6	UV Intensity (0%<--> 100%)
7	UV Intensity (0%<--> 100%)	---	---

DMX In-Depth Reference: 5/4-Channel Modes

5-Channel	Name	4-Channel	Name
1	Dimmer (0%<--> 100%)	1	Red Intensity (0%<--> 100%)
2	Amber Intensity (0%<--> 100%)	2	Green Intensity (0%<--> 100%)
3	White Intensity (0%<--> 100%)	3	Blue Intensity (0%<--> 100%)
4	UV Intensity (0%<--> 100%)	4	White Intensity (0%<--> 100%)
5	Virtual Color Wheel	---	---

5. APPENDIX

A Quick Lesson On DMX

DMX (aka DMX-512) was created in 1986 by the United States Institute for Theatre Technology (USITT) as a standardized method for connecting lighting consoles to lighting dimmer modules. It was revised in 1990 and again in 2000 to allow more flexibility. The Entertainment Services and Technology Association (ESTA) has since assumed control over the DMX512 standard. It has also been approved and recognized for ANSI standard classification.

DMX covers (and is an abbreviation for) Digital MultipleXed signals. It is the most common communications standard used by lighting and related stage equipment.

DMX provides up to 512 control "channels" per data link. Each of these channels was originally intended to control lamp dimmer levels. You can think of it as 512 faders on a lighting console, connected to 512 light bulbs. Each slider's position is sent over the data link as an 8-bit number having a value between 0 and 255. The value 0 corresponds to the light bulb being completely off while 255 corresponds to the light bulb being fully on.

DMX data is transmitted at 250,000 bits per second using the RS-485 transmission standard over two wires. As with microphone cables, a grounded cable shield is used to prevent interference with other signals.

There are five pins on a DMX connector: a wire for ground (cable shield), two wires for "Primary" communication which goes from a DMX source to a DMX receiver, and two wires for a "Secondary" communication which goes from a DMX receiver back to a DMX source. Generally, the "Secondary" channel is not used so data flows only from sources to receivers. Hence, most of us are most familiar with DMX-512 as being employer over typical 3-pin "mic cables," although this does not conform to the defined standard.

DMX is connected using a daisy-chain configuration where the source connects to the input of the first device, the output of the first device connects to the input of the next device, and so on. The standard allows for up to 32 devices on a single DMX link.

Troubleshooting

Symptom	Solution
Fixture Auto-Shut Off	Check the fan in the fixture. If it is stopped or moving slower than normal, the unit may have shut itself off due to high heat. This is to protect the fixture from overheating. Clear the fan of obstructions, or return the unit for service.
No Light Output	Check to ensure fixture is operating under correct mode, IE sound active/auto/DMX/Etc., if applicable.
Chase Speed Too Fast/Slow	Check to ensure proper setup of speed adjustment.
No Power	Check fuse, AC cord and circuit for malfunction.
Blown Fuse	Check AC cord and circuit for damage, verify that moving parts are not restricted and that unit's ventilation is not obstructed
No Response to Audio	Verify that the fixture is in "Sound Active" mode. Adjust Audio Sensitivity, If Applicable.
Fixture Not Responding / Responding Erratically	Make sure all connectors are seated properly and securely. Use Only DMX Cables and/or check cables for defects Install a Terminator. Reset fixture(s).

Keeping Your Colorise™ EXA As Good As New

The fixture you've received is a rugged, tough piece of pro lighting equipment, and as long as you take care of it, it will take care of you. That said, like anything, you'll need to take care of it if you want it to operate as designed. You should absolutely keep the fixture clean, especially if you are using it in an environment with a lot of dust, fog, haze, wild animals, wild teenagers or spilled drinks.

Cleaning the optics routinely with a suitable glass cleaner will greatly improve the quality of light output. Keeping the fans free of dust and debris will keep the fixture running cool and prevent damage from overheating.

In transit, keep the fixtures in cases. You wouldn't throw a prized guitar, drumset, or other piece of expensive gear into a gear trailer without a case, and similarly, you shouldn't even think about doing it with your shiny new light fixtures.

Common sense and taking care of your fixtures will be the single biggest thing you can do to keep them running at peak performance and let you worry about designing a great light show, putting on a great concert, or maximizing your client's satisfaction and "wow factor." That's what it's all about, after all!

Returns (Gasp!)

We've taken a lot of precautions to make sure you never even have to worry about sending a defective unit back, or sending a unit in for service. But, like any complex piece of equipment designed and built by humans, once in a while, something doesn't go as planned. If you find yourself with a fixture that isn't behaving like a good little fixture should, you'll need to obtain a Return Authorization (RA).

Don't worry, this is easy. Just send an email to support@blizzardlighting.com, and we'll issue you an RA. Then, you'll need to send the unit to us using a trackable, pre-paid freight method. We suggest using USPS Priority or UPS. Make sure you carefully pack the fixture for transit, and whenever possible, use the original box & packing for shipping.

When returning your fixture for service, be sure to include the following:

- 1.) Your contact information (Name, Address, Phone Number, Email address).
- 2.) The RA# issued to you
- 3.) A brief description of the problem/symptoms.

We will, at our discretion, repair or replace the fixture. Please remember that any shipping damage which occurs in transit to us is the customer's responsibility, so pack it well!

Shipping Issues

Damage incurred in shipping is the responsibility of the shipper, and must be reported to the carrier immediately upon receipt of the items. Claims must be made within seven (7) days of receipt.

Tech Specs!

Weight & Dimensions	
Width	10.7 inches (272.1 mm)
Depth	5.6 inches (141.4 mm)
Height	12.1 inches (307.9 mm)
Weight	11.5 lbs. (5.2 kg)
Power	
Operating Voltage	100-264VAC, 47-63 Hertz
Power Consumption	101W, 1.3A, PF: .64
Light Source	
LED	12x 15W 6-in-1 RGBAW+UV LEDs, 100,000 hours
Optical	
Beam Angle	25 degree optics standard
Luminous Intensity	13,680 Lux @ 1m 3,633 Lux @ 2m
AnyFi™ Wireless Receiver	
W-DMX™	Frequency Hopping W-DMX™ Protocol
Standard 2.4GHz	2.4GHz ISM (2.402-2.48Ghz), 512ch, 7 frequency groups
Latency	Less Than 5ms
Receiver Sensitivity	-94dBm
Thermal	
Max. Operating Temp.	104 degrees F (40 degrees C) ambient
Control	
Protocol	USITT DMX-512
DMX Channels	4/5/6/7/9 or 12-channel DMX modes
Input	3-pin XLR Male
Output	3-pin XLR Female
Other Operating Modes	Standalone, Master/Slave, Sound Active, Color Preset
Other Information	
I just wanted this sentence to be in the user manual.	
Warranty	2-year limited warranty, does not cover malfunction caused by damage to LEDs.

DISCLAIMER:

The power connector fitted to the fixture and fixture cord are designed for compatibility with products manufactured by Neutrik AG, Neutrik USA and their related entities, however they are not manufactured by, affiliated with or endorsed by Neutrik AG, Neutrik USA, or any related entity. Neutrik® and power-CON® are registered trademarks of Neutrik AG.

Dimensional Drawings

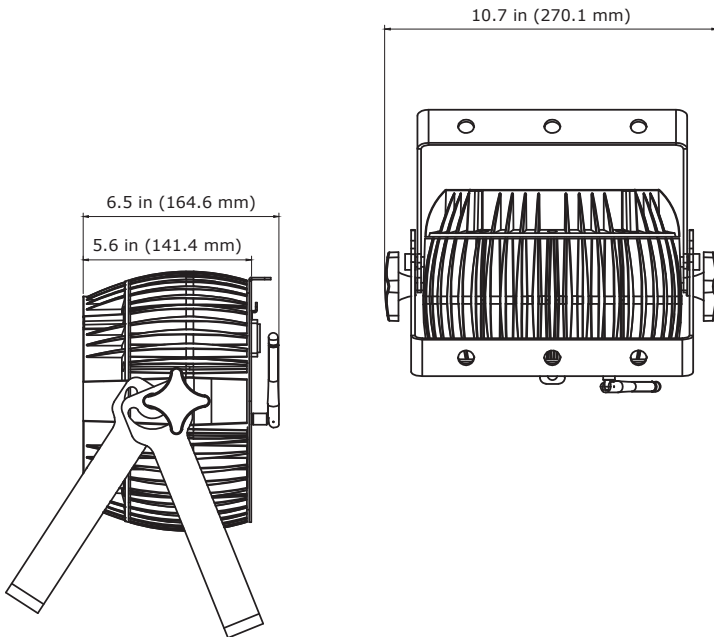
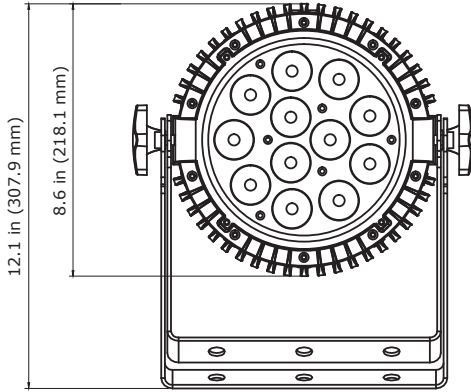



**Enjoy your product!
Our sincerest thanks for your purchase!
--The team @ Blizzard Lighting**