

Masiff.tm
architectural by blizzard lighting

fresco.

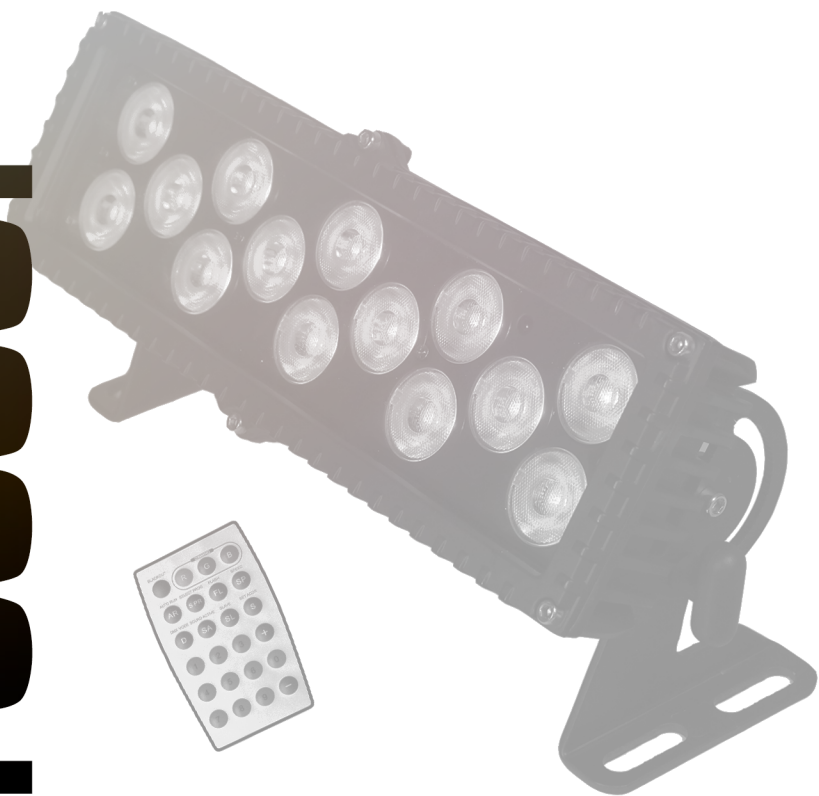

IR remote



DMX512 equipped



IP65 rated

TABLE OF CONTENTS

Motif Fresco™	1
1. Getting Started	3
What's In The Box?	3
Getting It Out Of The Box	3
Optional Accessories	3
Powering Up!	3
Getting A Hold Of Us	3
Safety Instructions (Don't Stick Your Hand In The Toaster!)	4
2. Meet The Motif Fresco™	5
Features	5
DMX Quick Reference	5
The Motif Fresco™ Pin-up Picture	6
3. Setup	7
Fuse Replacement	7
Connecting A Bunch Of Motif Fresco's	7
Data/DMX Cables	7
Cable Connectors	8
3-Pin??? 5-Pin??? Huh?	8
Take It To The Next Level: Setting up DMX Control	8
Fixture Linking (Master/Slave Mode)	9
Mounting/Rigging	9
4. Operating Adjustments	10
The Control Panel	10
Control Panel Menu Structure	11
DMX Mode	11
Slave Mode	11
Static Colors	12
Built-In Programs	12
Auto Mode	12
Manual Color Adjustments	12
Restore Factory Settings	12
Using the Remote Control	13
DMX Values In-Depth	15
5. Appendix	16
A Quick DMX Lesson	16
Troubleshooting	16
Keeping Your Motif Fresco™ As Good As New	17
Returns (Gasp!)	18
Shipping Issues	18
Tech Specs	19

1. GETTING STARTED

What's In The Box?

- 1 x Motif Fresco™ LED Fixture
- 1 x IP Rated AC Power Cord with Cable Cap
- This Lovely User Manual

Optional Accessories *(sold separately)*

The following accessories are available for this fixture. But being the lone wolves that they are, they need to be purchased separately! Contact your favorite Blizzard Lighting dealer for pricing.

- Motif Fresco Remote: IR Remote Control
- CABLE_MotifData3M: 3M IP-Rated DMX Extension
- CABLE_MotifDMXSET: 1M IP-Rated DMX IN/OUT Set
- CABLE_MotifPower3M: 3M IP-Rated Power Extension

Getting It Out Of The Box

Congratulations on purchasing one of the brightest, cutest little outdoor rated fixtures anywhere! Now that you've got your Motif Fresco™ (or hopefully, *Fresco's!*), you should carefully unpack the box and check the contents to ensure that all parts are present and in good condition. If anything looks as if it has been damaged in transit, notify the shipper immediately and keep the packing material for inspection. Again, please save the carton and all packing materials. If a fixture must be returned to the factory, it is important that the fixture be returned in the original factory box and packing.

Powering Up!

All fixtures must be powered directly off a switched circuit and **cannot be run off a rheostat (variable resistor) or dimmer circuit, even if the rheostat or dimmer channel is used solely for a 0% to 100% switch.**

AC Voltage Switch - Not all fixtures have a voltage select switch, so please verify that the fixture you receive is suitable for your local power supply. See the label on the fixture or refer to the fixture's specifications chart for more information. A fixture's listed current rating is its average current draw under normal conditions. Check the fixture or device carefully to make sure that if a voltage selection switch exists that it is set to the correct line voltage you will use.

Warning! Verify that the voltage select switch on your unit matches the line voltage applied. Damage to your fixture may result if the line voltage applied does not match the voltage indicated on the voltage selector switch. All fixtures must be connected to circuits with a suitable Ground (Earthing).

Getting A Hold Of Us

If something is wrong, just give us a call or send an email. We'll be happy to help, honest.

Blizzard Lighting
N16 W23390 Stoneridge Dr. Ste E
Waukesha, WI 53188 USA
www.blizzardlighting.com
414-395-8365
Email: support@blizzardlighting.com

Disclaimer: The information and specifications contained in this document are subject to change without notice. Blizzard Lighting™ assumes no responsibility or liability for any errors or omissions that may appear in this user manual. Blizzard Lighting™ reserves the right to update the existing document or to create a new document to correct any errors or omissions at any time. You can download the latest version of this document from www.blizzardlighting.com.

Author:	Date:	Last Edited:	Date:
J. Thomas	12/9/2013	J. Thomas	5/8/2014

SAFETY INSTRUCTIONS



Please read these instructions carefully. They include important information about the installation, usage and maintenance of this product.

- Please keep this User Guide for future use. If you sell the unit to someone else, be sure that they also receive this User Guide.
- ALWAYS make sure that you are connecting to the proper voltage, and that the line voltage you are connecting to is not higher than that stated on the decal or rear panel of the fixture.
- Make sure there are no flammable materials close to the unit while operating.
- The unit must be installed in a location with adequate ventilation, at least 20in (50cm) from adjacent surfaces. Be sure that no ventilation slots are blocked.
- ALWAYS disconnect from the power source before servicing or replacing fuse and be sure to replace with same fuse size and type.
- ALWAYS secure fixture using a safety chain. NEVER carry the fixture by its cord. Use its carrying handles.
- DO NOT operate at ambient temperatures higher than 104°F (40°C).
- In the event of a serious operating problem, stop using the unit immediately. NEVER try to repair the unit by yourself. Repairs carried out by unskilled people can lead to damage or malfunction. Please contact the nearest authorized technical assistance center. Always use the same type spare parts.
- NEVER connect the device to a dimmer pack.
- Make sure the power cord is never crimped or damaged.
- Never disconnect the power cord by pulling or tugging on the cord.
- Avoid direct eye exposure to the light source while it is on.

Caution! There are no user serviceable parts inside the unit. Do not open the housing or attempt any repairs yourself. In the unlikely event your unit may require service, please contact Blizzard Lighting at support@blizzardlighting.com.

2. MEET THE MOTIF FRESCO™

MAIN FEATURES

- Exceptional color mixing from 14x 3-watt TRI-color LEDs
- Advanced heat sink design for zero fan noise
- Multiple built-in color presets and auto programs
- User adjustable program speed & fade times
- 0-100% variable electronic dimmer
- Variable electronic strobe
- Durable cast aluminum housing and mounting brackets
- Tempered glass lens and watertight internal gaskets
- Built like a rock (It hits the gym regularly)
- USITT DMX-512 (3-channels)
- 3-pin Input/Output
- Easy to use IR remote control (sold separately)

DMX Quick Reference (3-Channel Mode)

Channel	What is does...
1	Red Intensity (0 <--> 100%)
2	Green Intensity (0 <--> 100%)
3	Blue Intensity (0 <--> 100%)

DMX Quick Reference (5-Channel Mode)

Channel	What is does...
1	Master Dimmer (0 <--> 100%)
2	Red Intensity (0 <--> 100%)
3	Green Intensity (0 <--> 100%)
4	Blue Intensity (0 <--> 100%)
5	Strobe (Slow <--> Fast)

DMX Quick Reference (7-Channel Mode)

Channel	What is does...
1	Master Dimmer (0 <--> 100%)
2	Red Intensity (0 <--> 100%)
3	Green Intensity (0 <--> 100%)
4	Blue Intensity (0 <--> 100%)
5	Built-In Programs
6	Speed (Slow <--> Fast)
7	Strobe (Slow <--> Fast)

Figure 1: The Motif Fresco™ Pin-Up Picture

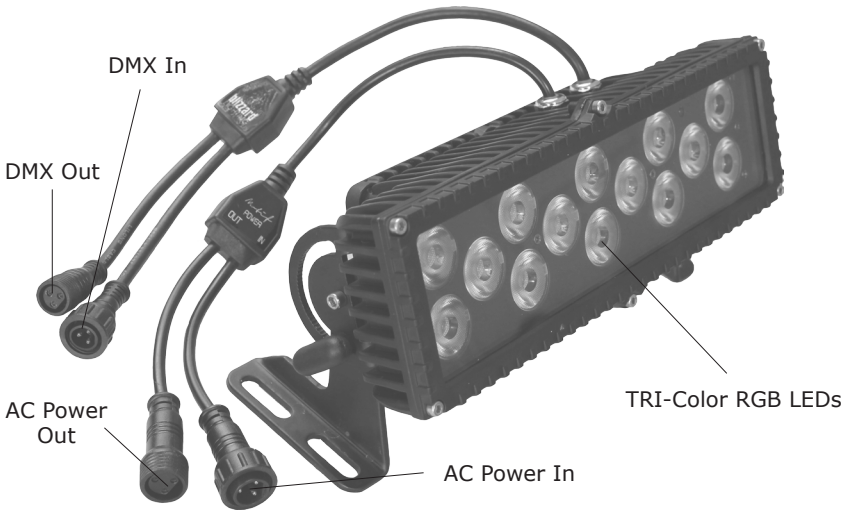
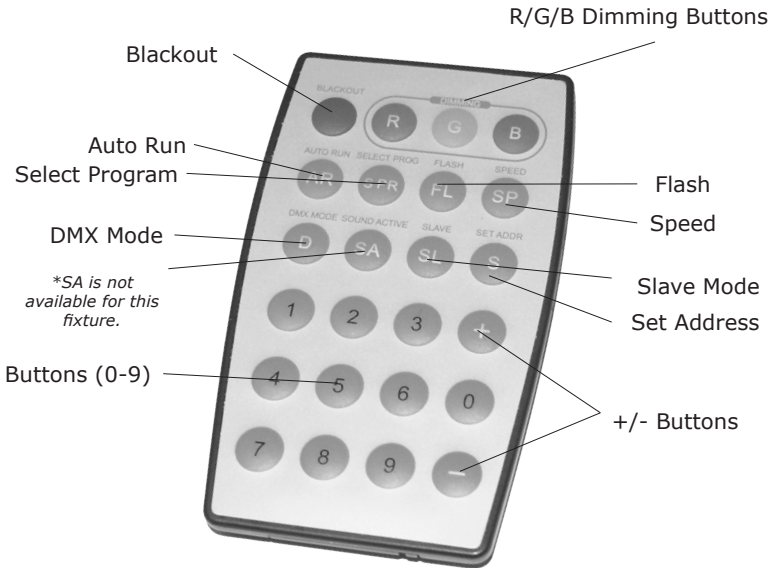

Figure 2: The Remote Control (sold separately)



3. SETUP



Before replacing a fuse, disconnect power cord. ALWAYS replace with the same type and rating of fuse.

Connecting A Bunch of Motif Fresco™ Fixtures

You will need a serial data link to run light shows using a DMX-512 controller or to run shows on two or more fixtures set to sync in master/slave operating mode. The combined number of channels required by all the fixtures on a serial data link determines the number of fixtures the data link can support.

Fixtures on a serial data link must be daisy chained in one single line. Also, connecting more than 32 fixtures on one serial data link without the use of a DMX optically-isolated splitter may result in deterioration of the digital DMX signal. The maximum recommended cable-run distance is 500 meters (1640 ft). The maximum recommended number of fixtures on a serial data link is 32 fixtures.

Data / DMX Cabling

To get a DMX signal into (or out to) standard 3-pin DMX cable, a Blizzard DMX adapter cable set (CABLE Motif DMX SET) must be used to convert the standard DMX plug to mini DMX plug (or vice versa). And when linking between any Motif Series units, a 3-meter mini DMX extension is available if necessary for your application (CABLE Motif Data3M). Both of these items are sold separately. Please contact your authorized Blizzard Lighting dealer to order either of these items.

All of your data cables should be a high-grade cable that can carry a strong signal, making them less prone to electromagnetic interference.

For instance, Belden© 9841 meets the specifications for EIA RS-485 applications. Standard microphone cables will "probably" be OK, but note that they cannot transmit DMX data as reliably over long distances. In any event, the cable should have the following characteristics:

*2-conductor twisted pair plus a shield
Maximum capacitance between conductors – 30 pF/ft.
Maximum capacitance between conductor & shield – 55 pF/ft.
Maximum resistance of 20 ohms / 1000 ft.
Nominal impedance 100 – 140 ohms*

Cable Connectors

Cables must have a male XLR connector on one end and a female XLR connector on the other end. (Duh!)

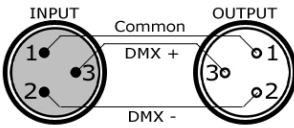

A Word on Termination: DMX is a resilient communication protocol, however errors still occasionally occur. Termination reduces signal errors, and therefore best practices include use of a terminator in all circumstances. If you are experiencing problems with erratic fixture behavior, especially over long signal cable runs, a terminator may help improve performance.

To build your own DMX Terminator:
Obtain a 120-ohm, 1/4-watt resistor, and wire it between pins 2 & 3 of the last fixture. They are also readily available from specialty retailers.

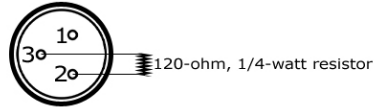

CAUTION: Do not allow contact between the common and the fixture's chassis ground. Grounding the common can cause a ground loop, and your fixture may perform erratically. Test cables with an ohm meter to verify correct polarity and to make sure the pins are not grounded or shorted to the shield or each other.

3-Pin??? 5-Pin??? Huh?!?

If you use a controller with a 5 pin DMX output connector, you will need to use a 5 pin to 3 pin adapter. They are widely available over the internet and from specialty retailers. If you'd like to build your own, the chart below details a proper cable conversion:

Conductor	3-Pin Female (Output)	5-Pin Male (Input)
Ground/Shield	Pin 1	Pin 1
DMX Data (-)	Pin 2	Pin 2
DMX Data (+)	Pin 3	Pin 3
Not Used.	No Connection.	No Connection.
Not Used.	No Connection.	No Connection.

Take It To The Next Level: Setting Up DMX Control

Step 1: Connect the male connector of the DMX cable to the female connector (output) on the controller.



Step 2: Connect the female connector of the DMX cable to the first fixture's male connector (input). *Note:* It doesn't matter which fixture address is the first one connected. We recommend connecting the fixtures in terms of their proximity to the controller, rather than connecting the lowest fixture number first, and so on.

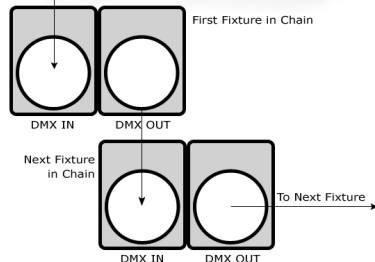

Step 3: Connect other fixtures in the chain from output to input as above. Place a DMX terminator on the output of the final fixture to ensure best communication.

Fixture Linking (Master/Slave Mode)

1. Connect the (male) 3 pin connector side of the DMX cable to the output (female) 3 pin connector of the first fixture.
2. Connect the end of the cable coming from the first fixture which will have a (female) 3 pin connector to the input connector of the next fixture consisting of a (male) 3 pin connector. Then, proceed to connect from the output as stated above to the input of the following fixture and so on.

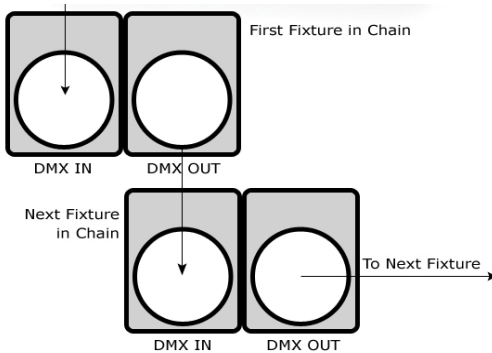

A quick note: Often, the setup for Master-Slave and Standalone operation requires that the first fixture in the chain be initialized for this purpose via either settings in the control panel or DIP-switches. Secondly, the fixtures that follow may also require a slave setting.

Check the **“Operating Adjustments”** section in this manual for complete instructions for this type of setup and configuration.

Mounting and Rigging

This fixture may be mounted in any SAFE position provided there is enough room for ventilation.

It is important never to obstruct the fan or vents pathway. Mount the fixture using a suitable “C” or “O” type clamp. The clamp should be rated to hold at least 10x the fixture’s weight to ensure structural stability. Do not mount to surfaces with unknown strength, and ensure properly “rated” rigging is used when mounting fixtures overhead.

Adjust the angle of the fixture by loosening both knobs and tilting the fixture. After finding the desired position, retighten both knobs.

- When selecting installation location, take into consideration lamp replacement access (if applicable) and routine maintenance.
- Safety cables **MUST ALWAYS** be used.
- Never mount in places where the fixture will be exposed to rain, high humidity, extreme temperature changes or restricted ventilation.

4. OPERATING ADJUSTMENTS

The Control Panel

All the goodies and different modes possible with this fixture can be accessed by using the control panel on the side of the fixture. There are 4 control buttons below the LED display which allow you to navigate through the various control panel menus.

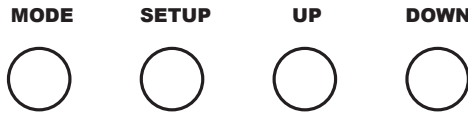

<MODE>

Is used to navigate the various modes.

<SETUP>

Is used to enter into the selected mode setup.

<UP>

Scrolls through menu items and numbers in ascending order.





<DOWN>

Scrolls through menu items and numbers in descending order.

The control panel LED display shows the menu items listed on the control panel menu structure on page 11. Use the **<MODE>** button to navigate your choices. To edit a setting, push the **<SETUP>** button, then use the **<UP>** and **<DOWN>** buttons again to scroll through your options.

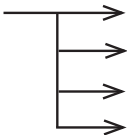
Control Panel Menu Structure

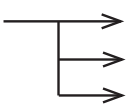
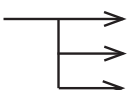
Note: The menu will automatically LOCK after 10 seconds of inactivity. To unlock the menu, press and hold <MODE>+<SETUP> for 2 seconds.

<i>d001</i>		<i>d001-d512</i>	To choose the DMX address
		<i>3-CH</i>	To choose 3 channel DMX mode
		<i>5-CH</i>	To choose 5 channel DMX mode
		<i>7-CH</i>	To choose 7 channel DMX mode
<i>SLAu</i>			Sets the fixture to run in slave mode
<i>Colr</i>		<i>r000-r255</i>	Red Intensity (0% <--> 100%)
		<i>g000-g255</i>	Green Intensity (0% <--> 100%)
		<i>b000-b255</i>	Blue Intensity (0% <--> 100%)
<i>Pr---</i>		<i>Pr01-Pr07</i>	Static colors (1), Programs (2-7)
		<i>SP01-SPFL</i>	Speed adjustment (slow <--> fast)
		<i>FS00-F599</i>	Strobe speed (slow <--> fast)
<i>AUFD</i>			Auto mode

DMX Mode

Allows the unit to be controlled by any universal DMX controller.

- 1.) The default mode for the fixture is DMX, which appears as **d001** on the LED read-out. To select a different DMX address, hit the **<SETUP>** button and use the **<UP/DOWN>** buttons to select the your desired starting DMX address ranging from **d001 - d512**, then hit **<SETUP>** again to confirm your choice.
- 2.) You can now use the **<UP/DOWN>** buttons to scroll through your choices of **3-ch**, **5-ch**, or **7ch**. Press **<MODE>** to confirm your choice.

Slave Mode

- 1.) To use as a slave unit, simply use the **<MODE>** button to scroll to **SLAu**. This fixture will now be in slave mode and follow the master unit, which is the fixture in the DMX chain.

Static Colors

- 1.) To use any of the built-in static colors, use the **<MODE>** button to scroll to **Pr-01**, and hit **<SETUP>**. Use the **<UP/DOWN>** buttons to scroll through the static color choices. Push the **<SETUP>** button to confirm your choice.
- 2.) Now you can adjust the strobe speed by selecting the strobe speed adjustment settings of **FS00 - FS99** (slow <--> fast).

Built-in Programs

- 1.) To set the fixture to run a single built-in program, use the **<MODE>** button to scroll to **Pr--**, and press the **<SETUP>** button. Then use the **<UP/DOWN>** buttons to scroll through the built-in program choices of **Pr02-Pr07** and push the **<SETUP>** button.
- 2.) Now you can adjust the speed of the program by using the **<UP/DOWN>** buttons and choose from **SP01 - SPFL** (slow <--> fast), and push the **<SETUP>** button. To conclude setup, you now have the option to adjust the strobe speed of the program by selecting the strobe adjustment settings of **FS00 - FS99** (slow <--> fast).

Auto Mode

- 1.) To set the fixture to run in auto mode, use the **<MODE>** button to scroll to **AUTO**, and hit **<SETUP>**.

Manual Color Adjustment:

Allows the user to adjust the color balance of the fixture. These settings are global, they will effect all modes.

- 1.) Use the **<MODE>** button to navigate to **Colr** and hit the **<SETUP>** button.
- 2.) From here, you can navigate to **r255, 9255, or b255** and use the **<UP/DOWN>** buttons to adjust the global intensity of red, green, or blue from **000-255**.

Restore Factory Settings

- 1.) First, unplug the power to the fixture so the fixture is off.
- 2.) Press and hold down the **<MODE>** and **<SETUP>** buttons together.
- 3.) While still holding down the two buttons, plug the power back in. Data restoration will initialize, resetting the unit back to its original factory settings.

Using The Remote Control

All the goodies and different modes possible with the Motif Fresco™ are also accessible by using the IR remote control (**sold separately**).

Setting the DMX Address

1.) To set the starting DMX address, push the **<S>** button. You'll see the LEDs flash 3 times in a sequence of colors that indicate the currently set DMX address. For example, if the DMX address is currently 001, the flashes would be white (zero)/ white (zero)/ red(one). (**See static color table**)

2.) Enter a 3-digit DMX address: 001-512.

3.) Now you'll see the LEDs flash 3 times per digit you enter, and notably, they will flash the assigned static color that corresponds to that digit. For example, setting the fixture to the DMX address of 010, the flashes would be white (zero)/ red (one)/ white (zero). (**See static color table**)

*You can use the remote control while in DMX mode to switch to any other mode. Press the **<D>** button on the remote to return to DMX mode.



Static Colors

To use fixture in static color mode, press either the **<R>**, **<G>**, or **** buttons, and then one of the numeric buttons (0-9). The color table below shows the static color for each number.

Static color table

Button 0	Button 1	Button 2	Button 3	Button 4
White	Red	Orange	Light Yellow	Green
Button 5	Button 6	Button 7	Button 8	Button 9
Cyan	Blue	Purple	Pink	Yellow

DMX Mode

The Motif Fresco™ will automatically recognizes a DMX signal when connected to a controller, and will function in 3-channel RGB color mixing mode. If the DMX signal is lost, the fixture will revert to its previously set mode.

You can use the remote control while in DMX mode to switch to any other mode. Then to return to DMX mode, press the **<D>** button.

Blackout

The blackout button on the remote control **** will turn off the LEDs, regardless of what mode you are currently running. Push the blackout **** button again to return to its previous mode.

Built-in Programs

To run one of the six built-in programs, press the **<SPR>** button. You will see the LEDs flash yellow, prompting you to then select a program number from buttons **<2-7>** on the numeric keys. You can also access static color mode from here by pressing button **<1>**.

Built-in programs

Button 2	Button 3	Button 4
7-Color Fade	3-Color Fade	Fantasy Color Fade
Button 5	Button 6	Button 7
7-Color Snap	3-Color Snap	Various Color Snap

Now you can adjust the program speed and flash (strobe) by pushing their corresponding buttons: **<SP>** button for speed, and the **<FL>** button for flash. Then use the **<+/->** buttons to adjust the rate. The **<+>** button will increase the speed, and **<->** button will decrease the speed.

Auto Mode

In auto mode, the fixture will run the built-in programs 2-7 in sequence. Press the **<AR>** button to start auto mode. Speed and flash setting will be inherited from your settings in program mode.

Manual Color Adjustment

This allows you to adjust the color balance of the fixture. These settings are global, they will effect all modes.

To adjust the intensity levels of red, green, or blue (0% - 100%), press either the **<R>**, **<G>**, or **** buttons on the remote control. Then use the **<+/->** buttons to adjust the intensity. The **<+>** button will increase the intensity, and **<->** button will decrease the intensity.

Slave Mode

To set the fixture to run in slave mode, push the **<SL>** button. The fixture is now in slave mode.

Restore Factory Settings

To restore the Motif Fresco™ back to its factory installed settings with the remote control, first press the blackout button **<BL>** to turn off the LEDs. Then, press the numeric keys **<9>**, **<8>**, and **<7>** in that order.

DMX Values In-Depth (7-Channel Mode)

Channel	Channel Value	What it does...
1	000 <-> 255	Master Dimmer (0 <-> 100%)
2	000 <-> 255	Red Intensity (0 <-> 100%)
3	000 <-> 255	Green Intensity (0 <-> 100%)
4	000 <-> 255	Blue Intensity (0 <-> 100%)
5	000 <-> 029 030 <-> 059 060 <-> 089 090 <-> 119 120 <-> 149 150 <-> 179 180 <-> 209 210 <-> 255	Channels 1-4 (Dimmer, Red, Green, Blue) Auto Mode Program 2 Program 3 Program 4 Program 5 Program 6 Program 7
6	000 <-> 255	Speed (Slow <-> Fast)
7	000 <-> 255	Strobe (Slow <-> Fast)

DMX Values In-Depth (5-Channel Mode)

Channel	Channel Value	What it does...
1	000 <-> 255	Master Dimmer (0 <-> 100%)
2	000 <-> 255	Red Intensity (0 <-> 100%)
3	000 <-> 255	Green Intensity (0 <-> 100%)
4	000 <-> 255	Blue Intensity (0 <-> 100%)
5	000 <-> 255	Strobe (Slow <-> Fast)

DMX Values In-Depth (3-Channel Mode)

Channel	Channel Value	What it does...
1	000 <-> 255	Red Intensity (0 <-> 100%)
2	000 <-> 255	Green Intensity (0 <-> 100%)
3	000 <-> 255	Blue Intensity (0 <-> 100%)

5. APPENDIX

A Quick Lesson On DMX

DMX covers (and is an abbreviation for) Digital MultipleXed signals. It is the most common communications standard used by lighting and related stage equipment.

DMX provides up to 512 control "channels" per data link. Each of these channels was originally intended to control lamp dimmer levels. You can think of it as 512 faders on a lighting console, connected to 512 light bulbs. Each slider's position is sent over the data link as an 8-bit number having a value between 0 and 255. The value 0 corresponds to the light bulb being completely off while 255 corresponds to the light bulb being fully on.

DMX data is transmitted at 250,000 bits per second using the RS-485 transmission standard over two wires. As with microphone cables, a grounded cable shield is used to prevent interference with other signals.

There are five pins on a DMX connector: a wire for ground (cable shield), two wires for "Primary" communication which goes from a DMX source to a DMX receiver, and two wires for a "Secondary" communication which goes from a DMX receiver back to a DMX source. Generally, the "Secondary" channel is not used so data flows only from sources to receivers. Hence, most of us are most familiar with DMX-512 as being employer over typical 3-pin "mic cables," although this does not conform to the defined standard.

DMX is connected using a daisy-chain configuration where the source connects to the input of the first device, the output of the first device connects to the input of the next device, and so on. The standard allows for up to 32 devices on a single DMX link.

Each receiving device typically has a means for setting the "starting channel number" that it will respond to. For example, if two 6-channel fixtures are used, the first fixture might be set to start at channel 1 so it would respond to DMX channels 1 through 6, and the next fixture would be set to start at channel 7 so it would respond to channels 7 through 12.

Troubleshooting

Symptom	Solution
Fixture Auto-Shut Off	Check the fan in the fixture. If it is stopped or moving slower than normal, the unit may have shut itself off due to high heat. This is to protect the fixture from overheating. Clear the fan of obstructions, or return the unit for service.
Beam is Dim	Check optical system and clean excess dust/grime. Also ensure that the 220V/110V switch is in the correct position, if applicable.
No Light Output	Check to ensure fixture is operating under correct mode, IE sound active/auto/DMX/Etc., if applicable. Contact service for more information.
Chase Speed Too Fast/Slow	Check to ensure proper setup of speed adjustment.
No Power	Check fuse, AC cord and circuit for malfunction.
No Response to Audio	Verify that the fixture is in "Sound Active" mode. Adjust Audio Sensitivity, If Applicable.
Fixture Not Responding / Responding Erratically	Make sure all connectors are seated properly and securely. Use Only DMX Cables. Install a Terminator. Check all cables for defects. Reset fixture(s).

Keeping Your Motif Fresco™ As Good As New

The fixture you've received is a rugged, tough piece of pro lighting equipment, and as long as you take care of it, it will take care of you. That said, like anything, you'll need to take care of it if you want it to operate as designed. You should absolutely keep the fixture clean, especially if you are using it in an environment with a lot of dust, fog, haze, wild animals, wild teenagers or spilled drinks.

Cleaning the optics routinely with a suitable glass cleaner will greatly improve the quality of light output. Keeping the fans free of dust and debris will keep the fixture running cool and prevent damage from overheating.

In transit, keep the fixtures in cases. You wouldn't throw a prized guitar, drumset, or other piece of expensive gear into a gear trailer without a case, and similarly, you shouldn't even think about doing it with your shiny new light fixtures.

Common sense and taking care of your fixtures will be the single biggest thing you can do to keep them running at peak performance and let you worry about designing a great light show, putting on a great concert, or maximizing your client's satisfaction and "wow factor." That's what it's all about, after all!

Returns - Gasp!

We've taken a lot of precautions to make sure you never even have to worry about sending a defective unit back, or sending a unit in for service. But, like any complex piece of equipment designed and built by humans, once in a while, something doesn't go as planned. If you find yourself with a fixture that isn't behaving like a good little fixture should, you'll need to obtain a Return Authorization (RA).

Don't worry, this is easy. Just send an email to support@blizzardlighting.com, and we'll issue you an RA. Then, you'll need to send the unit to us using a trackable, pre-paid freight method. We suggest using USPS Priority or UPS. Make sure you carefully pack the fixture for transit, and whenever possible, use the original box & packing for shipping.

When returning your fixture for service, be sure to include the following:

- 1.) Your contact information (Name, Address, Phone Number, Email address).
- 2.) The RA# issued to you
- 3.) A brief description of the problem/symptoms.

We will, at our discretion, repair or replace the fixture. Please remember that any shipping damage which occurs in transit to us is the customer's responsibility, so pack it well!

Shipping Issues

Damage incurred in shipping is the responsibility of the shipper, and must be reported to the carrier immediately upon receipt of the items. Claims must be made within seven (7) days of receipt.

Tech Specs!

Weight & Dimensions					
Width	11.81 inches (30 cm)				
Depth	3.15 inches (8 cm)				
Height	3.55 inches (9 cm)				
Weight	5.6 lbs (2.6 kg)				
Power					
Operating Voltage	100-240VAC, 50-60 Hertz				
Power Consumption	44W, .68A				
Light Source					
LED	14x 3-watt TRI-color LEDs, 100,000 hours.				
Optical					
Beam Angle	28 degrees				
Luminous Intensity	Lux/meter	Red	Green	Blue	All
	2m	515	820	900	2,010
Thermal					
Max. Operating Temp.	104 degrees F (40 degrees C) ambient				
Control					
Protocol	USITT DMX-512				
DMX Channels	3, 5, or 7-channel				
Input	3-pin XLR Male				
Output	3-pin XLR Female				
Other Operating Modes	Standalone, Master/Slave				
Coolness Factor					
Muy Fresco					
Warranty	2-year limited warranty, does not cover malfunction caused by damage to LED's.				

Dimensional Drawings

Fixture casing dimensions:

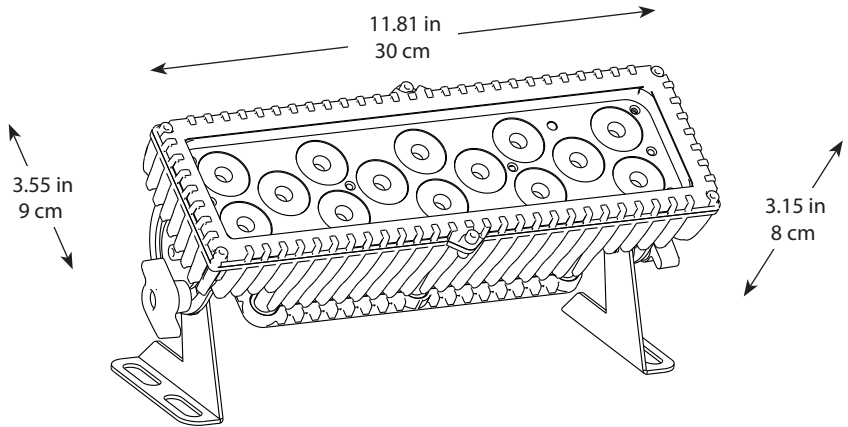

Casing w/bracket dimensions:

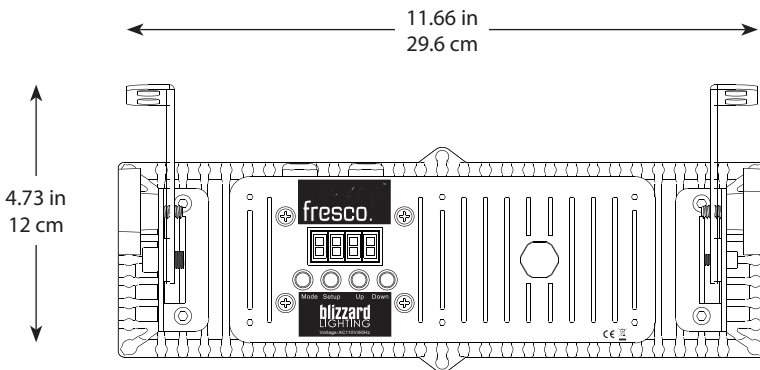

*Pointing the Motif Fresco™ straight up (lights up), brackets to face: 5.32 in (13.5 cm)

Motif.

we sincerely appreciate
you choosing our products.
so, from all of us,

thank you.

everything in this manual is copyright 2014 blizzard lighting, llc.
"motif," "fresco," and "blizzard," are TM and/or (R) blizzard lighting, llc
trees are beautiful and finite.
please recycle this manual if you aren't going to bother reading it :)