

# HD Video Conferencing Camera

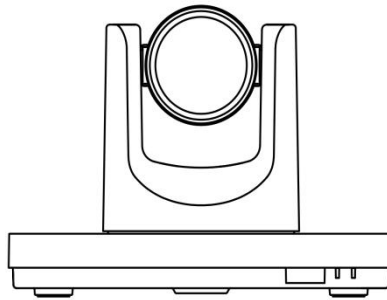

**User Manual**

**V1.4**

**(English)**

***InFocus***  
*The New Way to Collaborate*

---

## Preface

Thanks for using this HD Video Conferencing Camera.

This manual introduces the function, installation and operation of the HD camera. Prior to installation and usage, please read the manual thoroughly.

## Precautions

This product can only be used in the specified conditions in order to avoid any damage to the camera:

- Don't subject the camera to rain or moisture.
- Don't remove the cover. Otherwise, you may get an electric shock. In case of abnormal operation, contact the authorized engineer.
- Never operating under unspecified temperature , humidity and power supply;
- Please use the soft dry cloth to clean the camera. If the camera is very dirty, clean it with diluted neuter detergent; do not use any type of solvents, which may damages the surface.

## Note

This is class A production. Electromagnetic radiation at the specific frequency may affect the image quality of TV in home environment.

---

## Contents

1.	Note .....	3
2.	Supplied Accessories .....	4
3.	Quick Start .....	5
4.	Features .....	8
5.	Product Specification .....	9
6.	Main Unit .....	10
7.	IR Remote Controller Explanation .....	11
8.	Use IR Remote Controller .....	13
9.	RS-232C Interface .....	16
10.	Serial Communication Control .....	18
11.	Menu Setting .....	31
12.	Maintains and Trouble Shooting .....	37

---

## Note

- **Electric Safety**

Installation and operation must accord with electric safety standard.

- **Caution to transport**

Avoid stress, vibration and soakage in transport, storage and installation.

- **Polarity of power supply**

The power supply of the product is +12V, the max electrical current is 2A .Polarity of the power supply plug drawing as follows.



- **Careful of installation**

Don't grasp the camera head when carrying the camera. Don't turn camera head by hand. Doing so may result in mechanical damage.

Don't apply in corrosive liquid, gas or solid environment to avoid damaging the cover which is made up of plastic material.

To make sure no obstacle in rotation range.

Never power on before installation is not completed.

- **Don't dismantle the camera**

We are not responsible for any unauthorized modification or dismantling.

## CAUTION!

The specific frequency of electromagnetic field may affect the image of the camera!

---

## Supplied Accessories

When you unpack, check that all the supplied accessories are included:

Camera .....	1
AC power adaptor .....	1
Power cord .....	1
VISCA cable .....	1
RealCam Adapter .....	1
Remote controller.....	1
User manual .....	1

# Quick Start

Step1. Please check connections are correct before starting

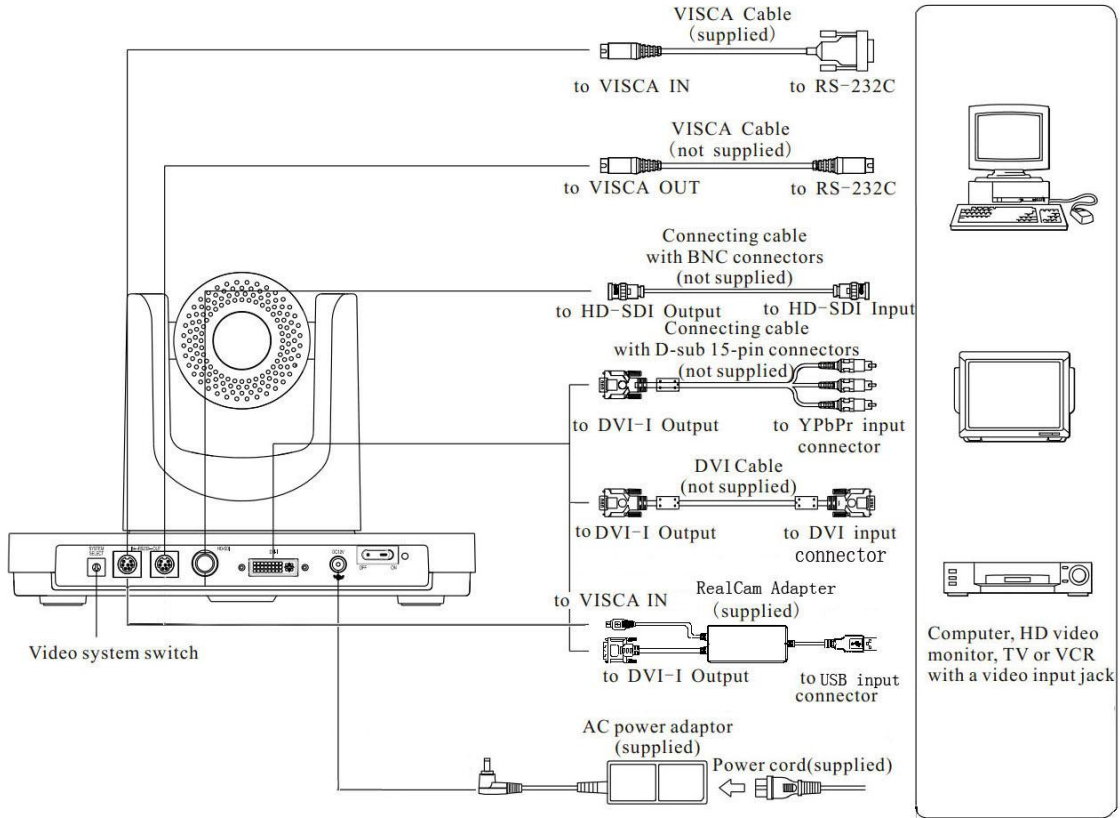

## Step2. Setting of the bottom switches

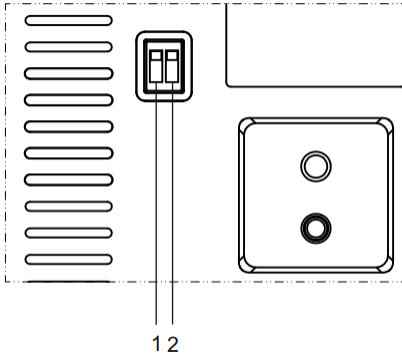

Set both of the switch1 and switch2 to 'OFF'. That is 'Normal Working Mode'.

	SW-1	SW-2	Modes
1	OFF	OFF	Normal Working Mode
2	ON	OFF	Software Update Mode
3	OFF	ON	Factory Debug Mode
4	ON	ON	None

## Step3. Setting of the system select switch

The option of video format:

VIDEO SYSTEM			
0	1080p60	8	720p30
1	1080p50	9	720p25
2	1080i60	A	1080p59.94
3	1080i50	B	1080i59.94
4	720p60	C	720p59.94
5	720p50	D	1080p29.97
6	1080p30	E	720p29.97
7	1080p25	F	-

### CAUTION:

- a. After changing the switch, you need to restart the camera to take effect.
- b. Please selecting the correct video format which the camera can support. If the camera so not support the video format you choose, the camera will choose default output video format.

---

Step4. Press the Switch ON/OFF button on the rear of the camera, the power lamp light.

Step5. Pan-Tilt will rotate to the maximum position of top right after the camera started, then it return to the center, the process of initialization is finished. (Note: If the position preset 0 has been stored, the position preset 0 will be called up after initialization)

Step6. (Optional)If you want to restore the factory default settings, Press [MENU] button to display the OSD menu. Select the item [MENU] ->[RESTORE DEFAULT] ->[Restore].Set the value[Yes], press [HOME] button to restore the factory default settings.

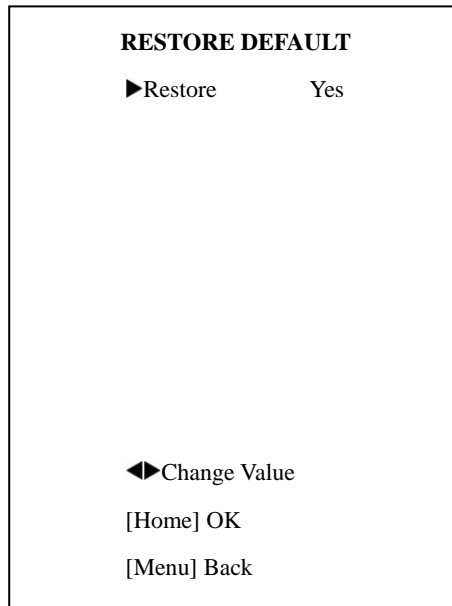



---

## Features

1. Integrated 72.5 degree wide-angle lens for the first time, Optical 12x.
2. Camera provides a high performance in low illumination situations, particularly suitable for which room's lighting is not very well.
3. With maximum resolution of 1920 x 1080 and output frame rate up to 60 or 50 frames / sec, this camera provides high-definition as well as fluent video.
4. The camera video signal to noise ratio directly affects the image compression coding efficiency for high-definition video conference terminals. With new low-noise CMOS sensor, camera applies 2D and 3D noise reduction at the same time based on motion estimation algorithm, and effectively reduces the noise.
5. Camera applies a unique Iridix dynamic exposure control algorithm, which is based on retina model. Good exposure makes the picture nature and creates a strong sense of space. The CMOS sensor also support WDR (Wide Dynamic Range) mode. With Iridix treatment, camera's WDR is capable of capture all features of images when there is a strong contrast between subject and background (such as backlight conditions).
6. Camera provide DVI-I interface (YPbPr: analog component video, DVI(HDMI): uncompressed digital video), HD-SDI Interface (Optional).
7. Infrared remote control signals pass through function. Camera is capable of receiving signal from the infrared remote controller, and pass through to the video conferencing terminal via VISCA IN connector.

## Product Specification

Model	S	M	C
Video Format	1080p/60, 1080p/59.94,1080p/50, 1080p/30, 1080p/29.97,1080p/25, 1080i/60, 1080i/59.94,1080i/50, 720p/60, 720p/59.94,720p/50, 720p/30, 720p/29.97,720p/25	1080p/30, 1080p/29.97,1080p/25, 1080i/60, 1080i/59.94,1080i/50, 720p/60, 720p/59.94,720p/50, 720p/30, 720p/29.97,720p/25	720p/60, 720p/59.94,720p/50, 720p/30, 720p/29.97,720p/25

Video Output Interface	DVI (HDMI, YPbPr), HD-SDI (Optional)	Tilt Speed Range	1.7 °~ 69.9 %s
Sensor Type	CMOS, 1/3 inch	Flick Mount	Supportable
Sensor Pixel	Effective Pixel: 2.07 million; Total Pixel: 2.74 million	Number of preset	128
Lens	12x, f3.5mm ~ 42.3mm, F1.8 ~ F2.8	Preset Accuracy	≤0.2 °
Focus Mode	Auto, Manual	Control Signal Interface	8 Pin Mini DIN
Electronic shutter	1/25s ~ 1/10000s	Support Protocol Type	VISCA, Pelco-D, Pelco-P
White Balance	Auto, Indoor, Outdoor, Manual	WDR Dynamic Range	≥100dB
Backlight Compensation	Supportable	Power Adapter	DC12V/2.0A
SNR	≥55dB	Power Consumption	12W
Horizontal Angle of View	72.5 °~ 6.9 °	Size	240mm x 144mm x 160mm
Vertical Angle of View	44.8 °~ 3.9 °	Color	Silver & Black
Horizontal Rotation Range	±170 °	Weight	2.5Kg
Vertical rotation range	-30 °~ +90 °	Operating Temperature	-5 ~ 50°C
Pan Speed Range	1.7 °~ 100 %s	Storage Temperature	-20 ~ 60°C

---

## Main Unit

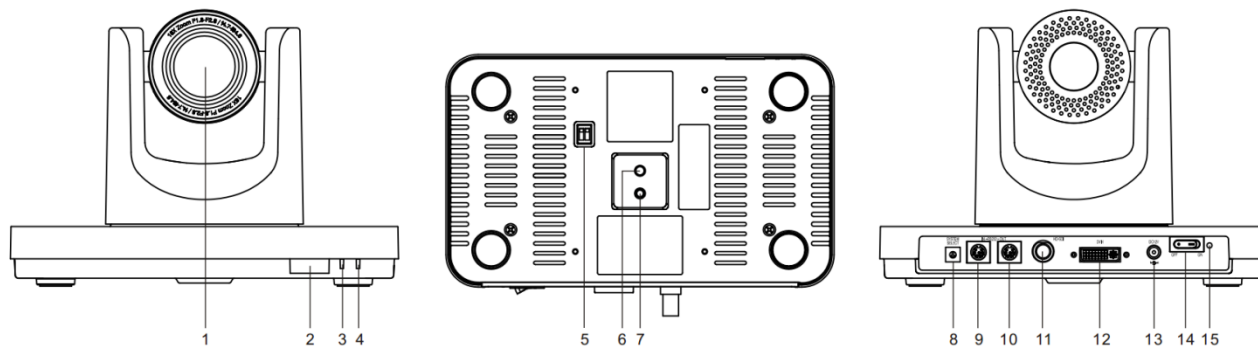

1. Lens
2. Sensor for the Remote Commander
3. POWER lamp
4. STANDBY lamp
5. BOTTOM switches
6. Tripod screw hole
7. Fixing screw whole
8. SYSTEM SELECT switch
9. RS232 IN jack
10. RS232 OUT jack
11. HD-SDI VIDEO jack (Optional)
12. DVI-I VIDEO jack
13. DC IN 12V Jack
14. POWER switch
15. POWER lamp

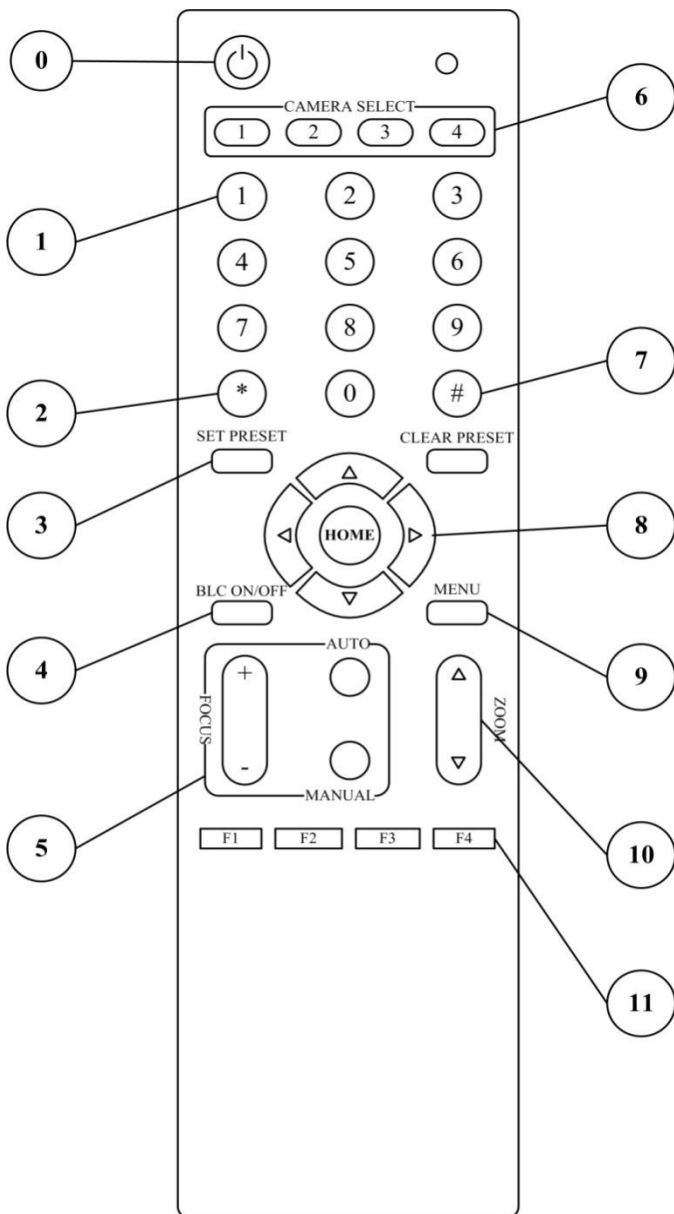

## IR Remote Controller Explanation

### 0. Standby Button

Press this button to enter standby mode. Press it again to enter normal mode.

(Note: Power consumption in standby mode is approximately half of the normal mode)

### 1. Position Buttons

To set preset or call preset

### 2. \* Button

### 3. Set/Clear Preset Buttons

**Set preset:** Store a preset position

[SET PRESET] + Numeric button (0-9): Setting a corresponding numeric key preset position

**Clear preset:** Erase a preset position

[CLEAR PRESET] + Numeric button (0-9)

Or: [\*]+[#]+[CLEAR PRESET]: Erase all the preset individually

Or: [#]+[#]+[#]: Erase all the preset

### 4. BLC (Backlight Compensation) Button

**BLC ON/OFF:** Press this button to enable the backlight compensation. Press it again to disable the backlight compensation. (NOTE: Effective only in auto exposure mode)

---

Notice: If a light behind the subject, the subject will become dark. In this case, press the backlight ON / OFF button. To cancel this function, press the backlight ON / OFF button.

## **5. Focus Buttons**

Used for focus adjustment.

Press [AUTO] button to adjust the focus automatically. To adjust the focus manually, press the [MANUAL] button, and adjust it with [Focus+] (Focus Far) and [Focus-] (Focus Near)

## **6. Camera Select Buttons**

Press the button corresponding to the camera you want to operate with the remote controller.

## **7. # Button**

## **8. Pan/Tilt Control Buttons**

Press arrow buttons to perform panning and tilting. Press [HOME] button to face the camera back to front

## **9. Menu Setting**

Menu button: Press this button to enter or exit the OSD menu

## **10. Zoom Buttons**

Zoom+: Zoom In

Zoom-: Zoom Out

## **11. Set Camera IR Address Buttons**

[\*]+[# ]+[F1]: Address1

[\*]+[# ]+[F2]: Address2

[\*]+[# ]+[F3]: Address3

[\*]+[# ]+[F4]: Address4

## USE IR Remote Controller

When the camera is working, you can use remote controller to perform panning, tilting, zooming and focusing, store and call back preset positions.

### Button Instruction:

1. In this instruction, ‘press the button’ means the press and relax the two actions. Such as ‘press [HOME] button’ means to press the [HOME] key and then relax action, and a special note will be given if a hold down for more than one second is required.

2. When a button-combination is required, do it in sequence. For example, ‘[\*] + [#] + [F1]’ means press [\*] first and then press [#] and press [F1] at last.

### 1. Pan/Tilt Control

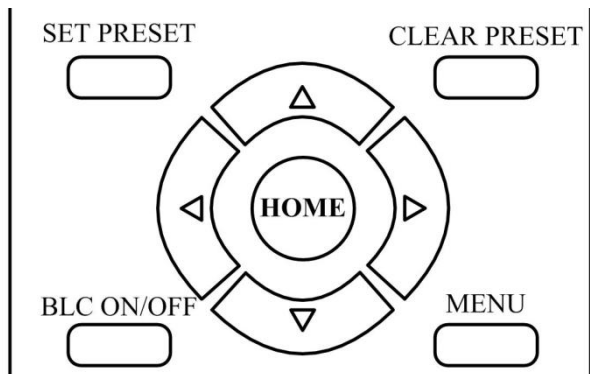

Move up: Press [▲]  
Move down: Press [▼]  
Move left: Press [◀]  
Move right: Press [▶]  
Face the camera back to front: Press [HOME]

Press and hold the up/down/left/right button, the camera will keep rotating from slow to fast, until it run to the mechanical limit; the camera stops as soon as the button is released.

### 2. Zoom

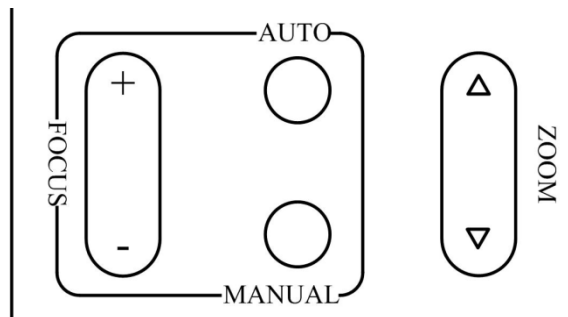

Zoom Out: press [ZOOM▼] button

Zoom In: press [ZOOM▲] button

Press and hold the button, the camera will keep zooming in or zooming out and it stops as soon as the button is released.

### 3. Focus Control

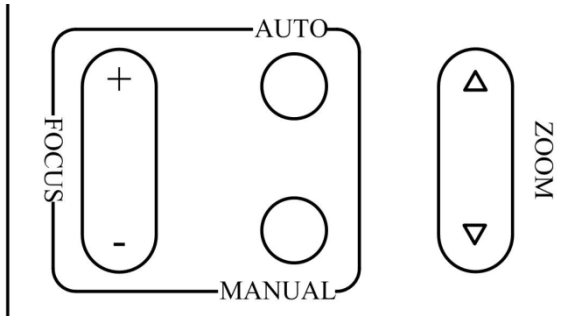

Focus Far: Press [FOCUS+] button

(**Note:** Effective only in manual focus mode)

Focus Near: Press [FOCUS-] button

(**Note:** Effective only in manual focus mode)

Press and hold the button, the action of focus continues and stops as soon as the button is released.

**AUTO:** Change focus mode to AF, adjusting the focus automatically.

**MANUAL:** Change focus mode to MF, adjusting the focus manually.

### 4. Backlight Switch

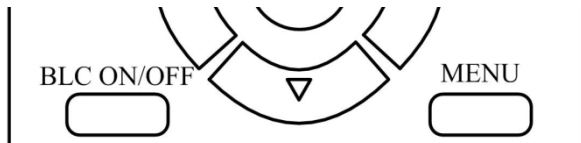

**BLC ON/OFF:** Press this button to enable the backlight compensation. Press it again to disable the backlight compensation. (**Note:** Backlight is only

effective in full auto exposure mode)

### 5. Presets Set/Clear

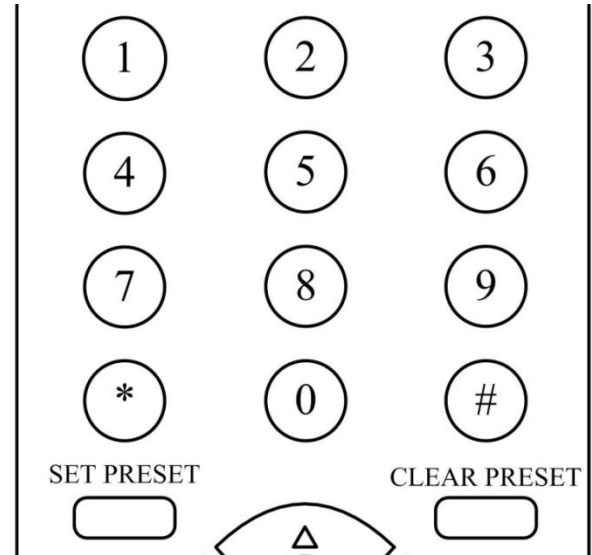

1. To store a preset position: The users should press the [SET PRESET] button first and then press the numeric button 0-9.

10 preset positions in total are available.

2. To erase the memory content of a preset position: The users should press the [CLEAR PRESET] button first and then press the numeric button 0-9.

**Note:**

Press [\*]+[#]+[CLEAR PRESET] will erase all preset positions in the memory.

Press [#]+[#]+[#] will erase all preset positions

in the memory.

## 6. Recalling the Preset

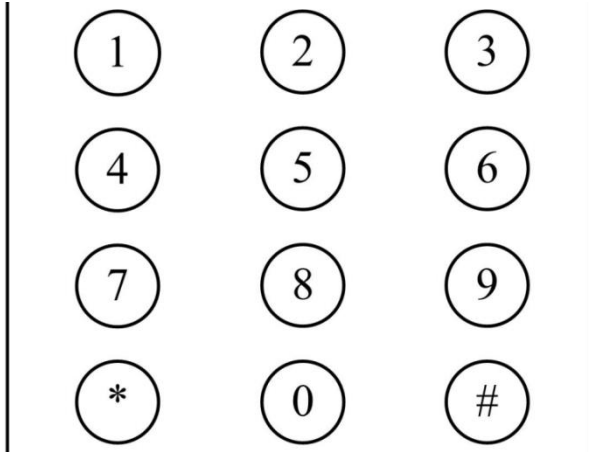

Press any of the numeric buttons 0-9 directly to recall stored preset positions and settings.

### **Note:**

No action is executed if a relative preset position is not stored.

## 7. Camera Selection

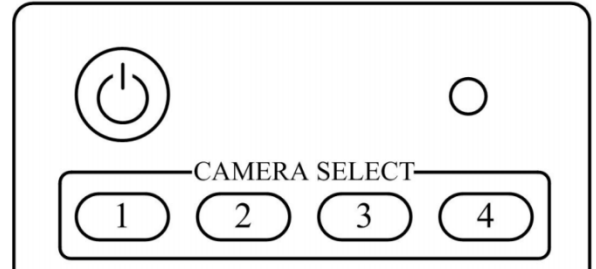

Press the button corresponding to the camera you want to operate.

## 8. Camera IR Address Set



[\*]+[#]+[F1]: Address1

[\*]+[#]+[F2]: Address2

[\*]+[#]+[F3]: Address3

[\*]+[#]+[F4]: Address4



# RS-232C Interface

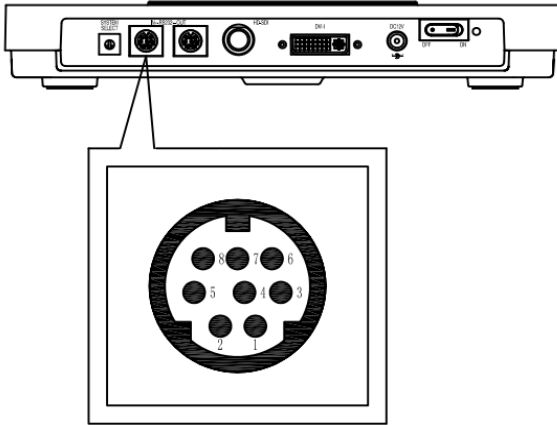

## Camera Windows DB-9

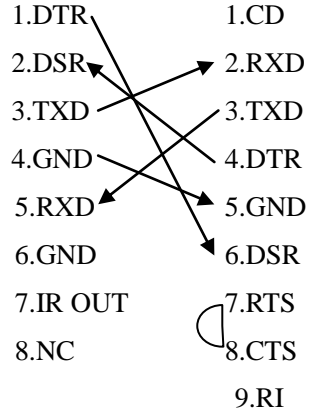

No.	Function
1	DTR
2	DSR
3	TXD
4	GND
5	RXD
6	GND
7	IR OUT
8	NC

## Camera Mini DIN

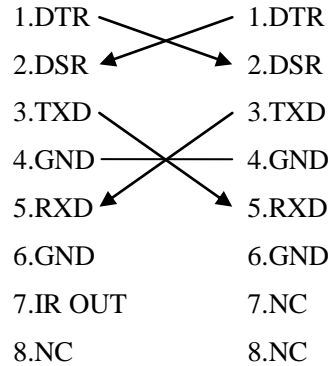

---

# VISCA Network Configuration

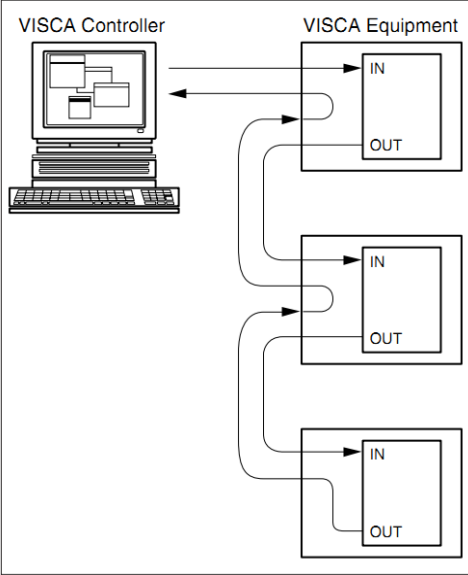

---

## Serial Communication Control

In default working mode, the camera is able to connect to a VISCA controller with RS232C serial interface.

The parameters of RS232C are as follows:

Baud rate: 2400/4800/9600 bit/s.

Start bit: 1 bit.

Data bit: 8 bits.

Stop bit: 1bit.

Parity bit: none.

Pan-Tilt will rotate to the maximum position of top right after the camera started, then it return to the center, the process of initialization is finished. (Note: If the position preset 0 has been stored, the position preset 0 will be called up after initialization) Then the users can control the camera with commands in the command list.

# VISCA Command List

## Part 1 Camera-Issued Messages

Ack/Completion Message		
Command	Command Packet	Comments
ACK	z0 41 FF	Returned when the command is accepted.
Completion	z0 51 FF	Returned when the command has been executed.

z = Camera Address+8

Error Messages		
Command	Command Packet	Comments
Syntax Error	z0 60 02 FF	Returned when the command format is different or when a command with illegal command parameters is accepted
Command Not Executable	z0 61 41 FF	Returned when a command cannot be executed due to current conditions. For example, when commands controlling the focus manually are received during auto focus.

## Part 2 Camera Control Command

Command	Function	Command Packet	Comments
AddressSet	Broadcast	88 30 01 FF	Address setting
IF_Clear	Broadcast	88 01 00 01 FF	I/F Clear
CommandCancel		8x 21 FF	
CAM_Power	On	8x 01 04 00 02 FF	Power ON/OFF
	Off	8x 01 04 00 03 FF	
CAM_Zoom	Stop	8x 01 04 07 00 FF	
	Tele(Standard)	8x 01 04 07 02 FF	

	Wide(Standard)	8x 01 04 07 03 FF	
	Tele(Variable)	8x 01 04 07 2p FF	p = 0(low) - 7(high)
	Wide(Variable)	8x 01 04 07 3p FF	
	Direct	8x 01 04 47 0p 0q 0r 0s FF	pqrs: Zoom Position
CAM_Focus	Stop	8x 01 04 08 00 FF	
	Far(Standard)	8x 01 04 08 02 FF	
	Near(Standard)	8x 01 04 08 03 FF	
	Far(Variable)	8x 01 04 08 2p FF	p = 0(low) - 7(high)
	Near(Variable)	8x 01 04 08 3p FF	
	Direct	8x 01 04 48 0p 0q 0r 0s FF	pqrs: Focus Position
	Auto Focus	8x 01 04 38 02 FF	AF ON/OFF
	Manual Focus	8x 01 04 38 03 FF	
Auto/Manual	8x 01 04 38 10 FF		
CAM_ZoomFocus	Direct	8x 01 04 47 0p 0q 0r 0s 0t 0u 0v 0w FF	pqrs: Zoom Position tuvw: Focus Position
CAM_WB	Auto	8x 01 04 35 00 FF	Normal Auto
	Indoor mode	8x 01 04 35 01 FF	Indoor mode
	Outdoor mode	8x 01 04 35 02 FF	Outdoor mode
	OnePush mode	8x 01 04 35 03 FF	One Push WB mode
	Manual	8x 01 04 35 05 FF	Manual Control mode
	Temperature mode	8x 01 04 35 2p FF	p:Color Temperature
CAM_RGain	Reset	8x 01 04 03 00 FF	Manual Control of R Gain
	Up	8x 01 04 03 02 FF	
	Down	8x 01 04 03 03 FF	
	Direct	8x 01 04 43 00 00 0p 0q FF	pq: R Gain
CAM_Bgain	Reset	8x 01 04 04 00 FF	Manual Control of B Gain
	Up	8x 01 04 04 02 FF	

	Down	8x 01 04 04 03 FF	
	Direct	8x 01 04 44 00 00 0p 0q FF	pq: B Gain
CAM_AE	Full Auto	8x 01 04 39 00 FF	Automatic Exposure mode
	Manual	8x 01 04 39 03 FF	Manual Control mode
	Shutter priority	8x 01 04 39 0A FF	Shutter Priority Automatic Exposure mode
	Iris priority	8x 01 04 39 0B FF	Iris Priority Automatic Exposure mode
	WDR	8x 01 04 39 21 FF	WDR mode
	Low Light	8x 01 04 39 22 FF	Low Light mode
CAM_Shutter	Reset	8x 01 04 0A 00 FF	Shutter Setting
	Up	8x 01 04 0A 02 FF	
	Down	8x 01 04 0A 03 FF	
	Direct	8x 01 04 4A 00 00 0p 0q FF	pq: Shutter Position
CAM_Iris	Reset	8x 01 04 0B 00 FF	Iris Setting
	Up	8x 01 04 0B 02 FF	
	Down	8x 01 04 0B 03 FF	
	Direct	8x 01 04 4B 00 00 0p 0q FF	pq: Iris Position
CAM_WDRStrength	Reset	8x 01 04 21 00 FF	WDR Level Setting
	Up	8x 01 04 21 02 FF	
	Down	8x 01 04 21 03 FF	
	Direct	8x 01 04 51 00 00 0p 0q FF	pq: WDR Level Position
CAM_LowLightLevel	Reset	8x 01 04 22 00 FF	Low Light Setting
	Up	8x 01 04 22 02 FF	
	Down	8x 01 04 22 03 FF	
	Direct	8x 01 04 52 00 00 0p 0q FF	pq: Low Light Position
CAM_ExpComp	On	8x 01 04 3E 02 FF	Exposure Compensation ON/OFF
	Off	8x 01 04 3E 03 FF	
	Reset	8x 01 04 0E 00 FF	Exposure Compensation Amount Setting
	Up	8x 01 04 0E 02 FF	

	Down	8x 01 04 0E 03 FF	
	Direct	8x 01 04 4E 00 00 0p 0q FF	pq: ExpComp Position
CAM_BackLight	On	8x 01 04 33 02 FF	Back Light Compensation ON/OFF
	Off	8x 01 04 33 03 FF	
CAM_NR(2D)	-	8x 01 04 53 0p FF	p: NR Setting (0: OFF, level 1 to 5)
CAM_NR(3D)	-	8x 01 04 54 0p FF	p: NR Setting (0: OFF, level 1 to 5)
CAM_Flicker	-	8x 01 04 23 0p FF	p: Flicker Settings(0: OFF, 1: 50Hz, 2: 60Hz)
CAM_Aperture	Reset	8x 01 04 02 00 FF	Aperture Control
	Up	8x 01 04 02 02 FF	
	Down	8x 01 04 02 03 FF	
	Direct	8x 01 04 42 00 00 0p 0q FF	pq: Aperture Gain
CAM_Memory	Reset	8x 01 04 3F 00 0p FF	p: Memory Number(=0 to 9)
	Set	8x 01 04 3F 01 0p FF	Corresponds to 0 to 9 on the Remote Commander.(Different with EVI-HD1)
	Recall	8x 01 04 3F 02 0p FF	
CAM_LR_Reverse	On	8x 01 04 61 02 FF	Image Flip Horizontal ON/OFF
	Off	8x 01 04 61 03 FF	
CAM_PictureFlip	On	8x 01 04 66 02 FF	Image Flip Vertical ON/OFF
	Off	8x 01 04 66 03 FF	
CAM_ColorGain	Diret	8x 01 04 49 00 00 00 0p FF	p: Color Gain setting 0h (60%) to Eh (200%)
CAM_ICR	ON	8x 01 04 01 02 FF	Infrared Mode ON/OFF
	OFF	8x 01 04 01 03 FF	
CAM_IDWrite		8x 01 04 22 0p 0q 0r 0s FF	pqrs: Camera ID (=0000 to FFFF)
IR_Receive	On	8x 01 06 08 02 FF	IR(remote commander)receive ON/OFF
	Off	8x 01 06 08 03 FF	
	On/Off	8x 01 06 08 10 FF	
IR_ReceiveResponse	On	8x 01 7D 01 03 00 00 FF	IR(remote commander)receive message via the VISCA communication ON/OFF
	Off	8x 01 7D 01 13 00 00 FF	
Pan_tiltDrive	Up	8x 01 06 01 VV WW 03 01 FF	VV: Pan speed 0x01 (low speed) to 0x18 (high

	Down	8x 01 06 01 VV WW 03 02 FF	speed)
	Left	8x 01 06 01 VV WW 01 03 FF	WW: Tilt speed 0x01 (low speed) to 0x14 (high
	Right	8x 01 06 01 VV WW 02 03 FF	speed)
	Upleft	8x 01 06 01 VV WW 01 01 FF	YYYY: Pan Position(TBD)
	Upright	8x 01 06 01 VV WW 02 01 FF	ZZZZ: Tilt Position(TBD)
	DownLeft	8x 01 06 01 VV WW 01 02 FF	
	DownRight	8x 01 06 01 VV WW 02 02 FF	
	Stop	8x 01 06 01 VV WW 03 03 FF	
	AbsolutePosition	8x 01 06 02 VV WW 0Y 0Y0Y0Y 0Z 0Z0Z0Z FF	
	RelativePosition	8x 01 06 03 VV WW 0Y 0Y0Y0Y 0Z 0Z0Z0Z FF	
	Home	8x 01 06 04 FF	
	Reset	8x 01 06 05 FF	
Pan_tiltLimitSet	LimitSet	8x 01 06 07 00 0W 0Y 0Y0Y0Y 0Z 0Z0Z0Z FF	W: 1 UpRight 0: DownLeft YYYY: Pan Limit Position ZZZZ: Tilt Position
	LimitClear	8x 01 06 07 01 0W 07 0F 0F0F 07 0F 0F0F FF	
CAM_AFSensitivity	High	8x 01 04 58 01 FF	AF Sensitivity High/Normal/Low
	Normal	8x 01 04 58 02 FF	
	Low	8x 01 04 58 03 FF	
CAM_SettingReset	Reset	8x 01 04 A0 10 FF	Reset Factory Setting
CAM_Iridix	Direct	8x 01 04 A7 00 00 0p 0q FF	pq: Iridix Position
Color System	RGB	8x 01 04 A8 02 FF	Only valid in 720p60/1080p60
	YPbPr	8x 01 04 A8 03 FF	
CAM_AWBSensitivity	High	8x 01 04 A9 00 FF	High
	Normal	8x 01 04 A9 01 FF	Normal
	Low`	8x 01 04 A9 02 FF	Low



CAM_AFZone	Top	8x 01 04 AA 00 FF	AF Zone weight select
	Center	8x 01 04 AA 01 FF	
	Bottom	8x 01 04 AA 02 FF	
CAM_DVIMode	HDMI	8x 01 04 AB 02 FF	DVI output mode, default: HDMI
	DVI	8x 01 04 AB 03 FF	
CAM_ColorHue	Direct	8x 01 04 4F 00 00 00 0p FF	p: Color Hue setting 0h (- 7degrees) to Eh (+7 degrees)
CAM_Gamma		8x 01 04 5B 0p FF	p: Gamma setting (0x00~0x0A)

### Part 3 Query Command

Command	Command packed	Inquiry Packet	Comments
CAM_PowerInq	8x 09 04 00 FF	y0 50 02 FF	On
		y0 50 03 FF	Off(Standby)
CAM_ZoomPosInq	8x 09 04 47 FF	y0 50 0p 0q 0r 0s FF	pqrs: Zoom Position
CAM_FocusAFModeInq	8x 09 04 38 FF	y0 50 02 FF	Auto Focus
		y0 50 03 FF	Manual Focus
CAM_FocusPosInq	8x 09 04 48 FF	y0 50 0p 0q 0r 0s FF	pqrs: Focus Position
CAM_WBModeInq	8x 09 04 35 FF	y0 50 00 FF	Auto
		y0 50 01 FF	Indoor mode
		y0 50 02 FF	Outdoor mode
		y0 50 03 FF	OnePush mode
		y0 50 05 FF	Manual
		y0 50 2p FF	p:Color Temperature
CAM_RGainInq	8x 09 04 43 FF	y0 50 00 00 0p 0q FF	pq: R Gain
CAM_BGainInq	8x 09 04 44 FF	y0 50 00 00 0p 0q FF	pq: B Gain
CAM_AEModeInq	8x 09 04 39 FF	y0 50 00 FF	Full Auto
		y0 50 03 FF	Manual
		y0 50 0A FF	Shutter priority

		y0 50 0B FF	Iris priority
		y0 50 21 FF	WDR
		y0 50 22 FF	Low Light
CAM_ShutterPosInq	8x 09 04 4A FF	y0 50 00 00 0p 0q FF	pq: Shutter Position
CAM_IrisPosInq	8x 09 04 4B FF	y0 50 00 00 0p 0q FF	pq: Iris Position
CAM_WDRStrengthInq	8x 09 04 B1 FF	y0 50 00 00 0p 0q FF	pq: WDR Strength
CAM_LowLightLevInq	8x 09 04 B2 FF	y0 50 00 00 0p 0q FF	pq: Low Light Level
CAM_ExpCompModeInq	8x 09 04 3E FF	y0 50 02 FF	On
		y0 50 03 FF	Off
CAM_ExpCompPosInq	8x 09 04 4E FF	y0 50 00 00 0p 0q FF	pq: ExpComp Position
CAM_BacklightModeInq	8x 09 04 33 FF	y0 50 02 FF	On
		y0 50 03 FF	Off
CAM_Noise2DModeInq	8x 09 04 53 FF	y0 50 0p FF	Noise Reduction (2D) p: 0 to 5
CAM_Noise3DModeInq	8x 09 04 54 FF	y0 50 0p FF	Noise Reduction (3D) p: 0 to 5
CAM_FlickerModeInq	8x 09 04 55 FF	y0 50 0p FF	p: Flicker Settings(0: OFF, 1: 50Hz, 2: 60Hz)
CAM_ApertureInq	8x 09 04 42 FF	y0 50 00 00 0p 0q FF	pq: Aperture Gain
CAM_MemoryInq	8x 09 04 3F FF	y0 50 0p FF	p: Memory number last operated.
SYS_MenuModeInq	8x 09 06 06 FF	y0 50 02 FF	On
		y0 50 03 FF	Off
CAM_LR_ReverseInq	8x 09 04 61 FF	y0 50 02 FF	On
		y0 50 03 FF	Off
CAM_PictureFlipInq	8x 09 04 66 FF	y0 50 02 FF	On
		y0 50 03 FF	Off
CAM_IDInq	8x 09 04 22 FF	y0 50 0p 0q 0r 0s FF	pqrs: Camera ID
CAM_VersionInq	8x 09 00 02 FF	y0 50 ab cd mnpqrstuvw FF	ab: Factory Code(08: VHD) cd: Hardware Version mnpq: ARM Version rstu: FPGA Version

			vw: Socket Number
VideoSystemInq	8x 09 06 23 FF	y0 50 00 FF	1920x1080i60
		y0 50 01 FF	1920x1080p30
		y0 50 02 FF	1280x720p60
		y0 50 03 FF	1280x720p30
		y0 50 07 FF	1920x1080p60
		y0 50 08 FF	1920x1080i50
		y0 50 09 FF	1920x1080p25
		y0 50 0A FF	1280x720p50
		y0 50 0B FF	1280x720p25
		y0 50 0F FF	1920x1080p50
IR_Receive	8x 09 06 08 FF	y0 50 02 FF	On
		y0 50 03 FF	Off
IR_ReceiveReturn		y0 07 7D 01 04 00 FF	Power ON/OFF
		y0 07 7D 01 04 07 FF	Zoom tele/wide
		y0 07 7D 01 04 38 FF	AF On/Off
		y0 07 7D 01 04 33 FF	CAM_Backlight
		y0 07 7D 01 04 3F FF	CAM_Memory
		y0 07 7D 01 06 01 FF	Pan_tiltDrive
Pan-tiltMaxSpeedInq	8x 09 06 11 FF	y0 50 wwzz FF	ww: Pan Max Speed zz: Tilt Max Speed
Pan-tiltPosInq	8x 09 06 12 FF	y0 50 0w 0w0w0w 0z 0z0z0z FF	www: Pan Position zzz: Tilt Position
CAM_AFSensitivityInq	8x 09 04 58 FF	y0 50 01 FF	High
		y0 50 02 FF	Normal
		y0 50 03 FF	Low
CAM_IridixInq	8x 09 04 A7 FF	y0 50 00 00 0p 0q FF	pq: Iridix Position
Color System Inq	8x 09 04 A8 FF	y0 50 02 FF	VGA Mode On
		y0 50 03 FF	VGA Mode Off

CAM_GammaInq	8x 09 04 5B FF	y0 50 0p FF	p: Gamma setting (0x00~0x0A)
CAM_AFZone	8x 09 04 AA FF	y0 50 00 FF	Top
		y0 50 01 FF	Center
		y0 50 02 FF	Bottom
CAM_DVIModeInq	8x 09 04 AB FF	y0 50 02 FF	DVI Mode: HDMI
		y0 50 03 FF	DVI Mode: DVI
CAM_ColorHueInq	8x 09 04 4F FF	y0 50 00 00 00 0p FF	p: Color Hue setting 0h (- 7degrees) to Eh (+7 degrees)
CAM_AWBSensitivityInq	8x 09 04 A9 FF	y0 50 00 FF	High
		y0 50 01 FF	Normal
		y0 50 02 FF	Low

## Part 4 Custom control command

Command	Function	Command Packaged	Comments
CAM_Power	On	8x 02 16 16 16 65 FF	Custom Power ON/OFF
	OFF(Standby)	8x 02 16 16 16 56 FF	
TCL_Power	TCL Standby	8x 01 02 75 75 01 04 FF	Forwarding AD DA 02 B0 01 04 AF FA
	TCL Wakeup	8x 01 02 75 75 00 03 FF	Forwarding AD DA 02 B0 00 03 AF FA

## Part 5 Customize the query command

Command	Command Packaged	Ack Packaged	Comments
CAM_StatusInq	8x 02 20 01 01 FF	y0 50 0p 00 0q rs 0t 0u FF	p:Error code q:License rs:Video format t:Flip mode u:Running status

### Note:

The [x] in the above table is the camera address, [y] = [x + 8].

## Pelco-D Protocol Command List

Function	Byte1	Byte2	Byte3	Byte4	Byte5	Byte6	Byte7
Up	0xFF	Address	0x00	0x08	Pan Speed	Tilt Speed	SUM
Down	0xFF	Address	0x00	0x10	Pan Speed	Tilt Speed	SUM
Left	0xFF	Address	0x00	0x04	Pan Speed	Tilt Speed	SUM
Right	0xFF	Address	0x00	0x02	Pan Speed	Tilt Speed	SUM
Zoom In	0xFF	Address	0x00	0x20	0x00	0x00	SUM
Zoom Out	0xFF	Address	0x00	0x40	0x00	0x00	SUM
Focus Far	0xFF	Address	0x00	0x80	0x00	0x00	SUM
Focus Near	0xFF	Address	0x01	0x00	0x00	0x00	SUM
Set Preset	0xFF	Address	0x00	0x03	0x00	Preset ID	SUM
Clear Preset	0xFF	Address	0x00	0x05	0x00	Preset ID	SUM
Call Preset	0xFF	Address	0x00	0x07	0x00	Preset ID	SUM
Auto Focus	0xFF	Address	0x00	0x2B	0x00	0x01	SUM
Manual Focus	0xFF	Address	0x00	0x2B	0x00	0x02	SUM
Query Pan Position	0xFF	Address	0x00	0x51	0x00	0x00	SUM
Query Pan Position Response	0xFF	Address	0x00	0x59	Value High Byte	Value Low Byte	SUM
Query Tilt Position	0xFF	Address	0x00	0x53	0x00	0x00	SUM
Query Tilt Position Response	0xFF	Address	0x00	0x5B	Value High Byte	Value Low Byte	SUM
Query Zoom Position	0xFF	Address	0x00	0x55	0x00	0x00	SUM
Query Zoom Position Response	0xFF	Address	0x00	0x5D	Value High Byte	Value Low Byte	SUM

## Pelco-P Protocol Command List

Function	Byte1	Byte2	Byte3	Byte4	Byte5	Byte6	Byte7	Byte8
Up	0xA0	Address	0x00	0x08	Pan Speed	Tilt Speed	0xAF	XOR
Down	0xA0	Address	0x00	0x10	Pan Speed	Tilt Speed	0xAF	XOR
Left	0xA0	Address	0x00	0x04	Pan Speed	Tilt Speed	0xAF	XOR
Right	0xA0	Address	0x00	0x02	Pan Speed	Tilt Speed	0xAF	XOR
Zoom In	0xA0	Address	0x00	0x20	0x00	0x00	0xAF	XOR
Zoom Out	0xA0	Address	0x00	0x40	0x00	0x00	0xAF	XOR
Focus Far	0xA0	Address	0x00	0x80	0x00	0x00	0xAF	XOR
Focus Near	0xA0	Address	0x01	0x00	0x00	0x00	0xAF	XOR
Set Preset	0xA0	Address	0x00	0x03	0x00	Preset ID	0xAF	XOR
Clear Preset	0xA0	Address	0x00	0x05	0x00	Preset ID	0xAF	XOR
Call Preset	0xA0	Address	0x00	0x07	0x00	Preset ID	0xAF	XOR
Auto Focus	0xA0	Address	0x00	0x2B	0x00	0x01	0xAF	XOR
Manual Focus	0xA0	Address	0x00	0x2B	0x00	0x02	0xAF	XOR
Query Pan Position	0xA0	Address	0x00	0x51	0x00	0x00	0xAF	XOR
Query Pan Position Response	0xA0	Address	0x00	0x59	Value High Byte	Value Low Byte	0xAF	XOR
Query Tilt Position	0xA0	Address	0x00	0x53	0x00	0x00	0xAF	XOR
Query Tilt Position Response	0xA0	Address	0x00	0x5B	Value High Byte	Value Low Byte	0xAF	XOR
Query Zoom Position	0xA0	Address	0x00	0x55	0x00	0x00	0xAF	XOR
Query Zoom Position Response	0xA0	Address	0x00	0x5D	Value High Byte	Value Low Byte	0xAF	XOR

---

# Menu Setting

## 1. MENU

Press [MENU] button to display the main menu on the normal screen, using arrow button to move the cursor to the item to be set. Press the [HOME] button to enter the corresponding sub-menu.

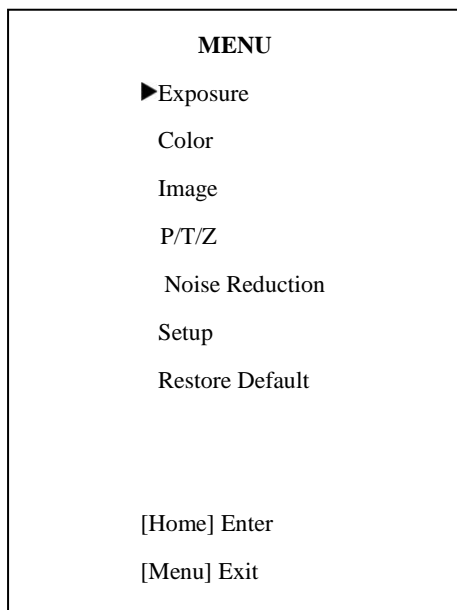

## 2. EXPOSURE

Move the cursor to the Exposure item in the main menu and press [HOME] button, EXPOSURE menu appears, as shown in the following figure.

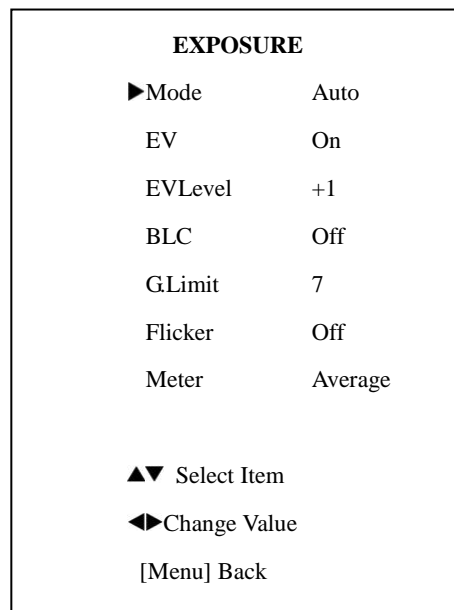

Mode: Exposure mode. Optional items: Auto, Manual, SAE, AAE, Bright, WDR

EV: Exposure compensation switch. Optional items: Off, On

EVLevel: Exposure compensation level. Optional items: -7 ~ +7

BLC: Backlight compensation switch. Optional items: Off, On

GLimit: Maximum gain limit. Optional items: 0 ~ +F

Flicker: Anti-flicker. Optional items: Off, 50Hz,



60Hz

Iris: Aperture value. Optional items: F1.8, F2.0, F2.4, F2.8, F3.4, F4.0, F4.8, F5.6, F6.8, F8.0, F9.6, F11.0, Close (Effective only in Manual, AAE mode)

Shutt: Shutter value. Optional items: 1/2,1/4,1/8, 1/15, 1/30, 1/60, 1/90, 1/100, 1/125, 1/180, 1/250, 1/350, 1/500, 1/725, 1/1000, 1/1500, 1/2000, 1/3000, 1/4000, 1/6000, 1/10000 (Effective only in Manual, SAE mode)

Stren: WDR strength. Optional items: 0~6(Effective only in WDR mode)

Meter: Metering mode, Optional items: Average, Center

Bright: Intensity control, Optional items:00~23

### 3. COLOR

Move the cursor to the Color item in the main menu and press [HOME] button, COLOR menu appears, as shown in the following figure.

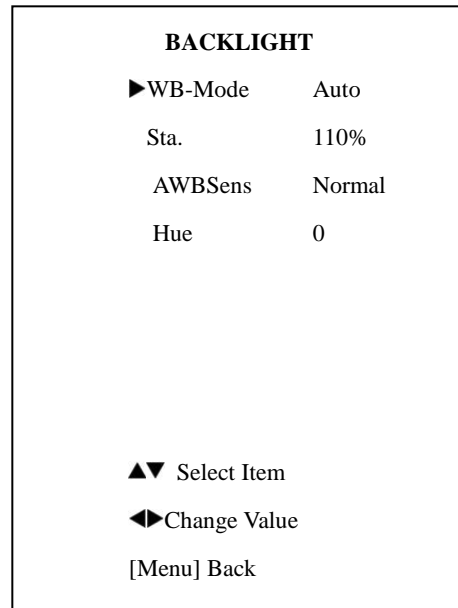

WB-Mode: White balance mode. Optional items: Auto, Indoor, Outdoor, Manual

RG: Red gain. Optional items: 0~255(Effective only in Manual mode)

BG: Blue gain. Optional items: 0~255(Effective only in Manual mode)

Sat.: Saturation. Optional items: 60% ~ 200%

AWBSens: The white balance sensitivity, Optional items: Low, Normal, High

Hue: Automatic white balance is tonal, Optional items:-7~ +7, Default 0 (Effective only in Manual mode)

---

## 4. IMAGE

Move the cursor to the Image item in the main menu and press [HOME] button, IMAGE menu appears, as shown in the following figure.

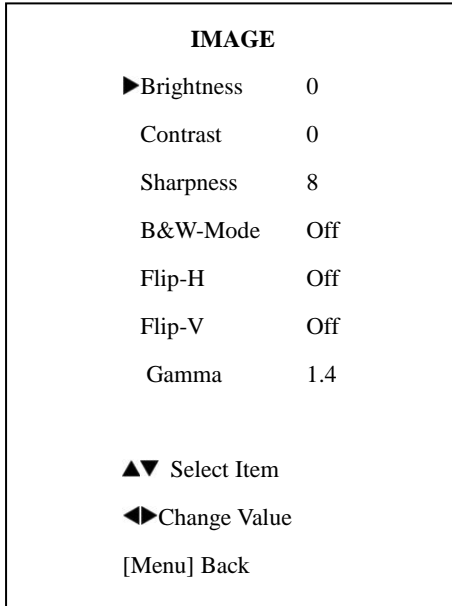

Brightness: Brightness adjustment. Optional items: -5 ~ +5

Contrast: Contrast adjustment. Optional items: -5 ~ +5

Sharpness: Sharpness adjustment. Optional items: 0 ~ 15

B&W-Mode: Black and white mode switch. Optional items: On, Off

Flip-H: Image flipped horizontally. Optional

items: On, Off

Flip-V: Image Flip Vertical. Optional items: On, Off

Gamma: Gamma adjust, Optional items: 0.5~1.5

## 5. P/T/Z

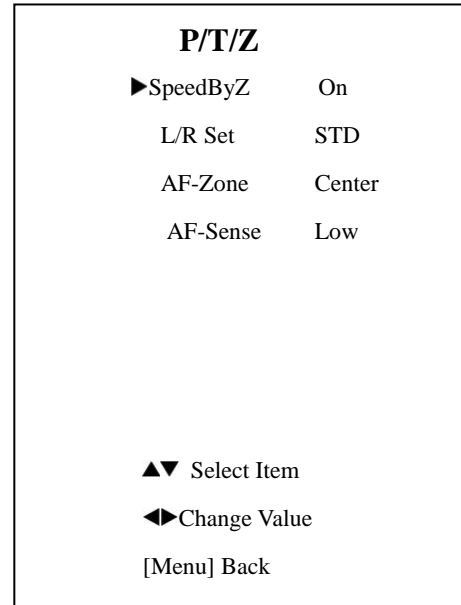

SpeedByZ: The depth of field scale switch, Optional items: On, Off

SpeedByZ On: Zoom PTZ the larger of the focal length ,camera P / T moving more slowly.

L/R Set: Reverse setting remote control, Optional items: STD, REV (When set to REV, remote

---

control or reverse)

AF-Zone: Interested in focusing area, Optional items: Center, Bottom, Top

AF-Sense: Automatic focusing sensitivity options, Optional items: Low, Normal, High

## 6. NOISE REDUCTION

Move the cursor to the Noise Reduction item in the main menu and press [HOME] button, NOISE REDUCTION menu appears, as shown in the following figure.

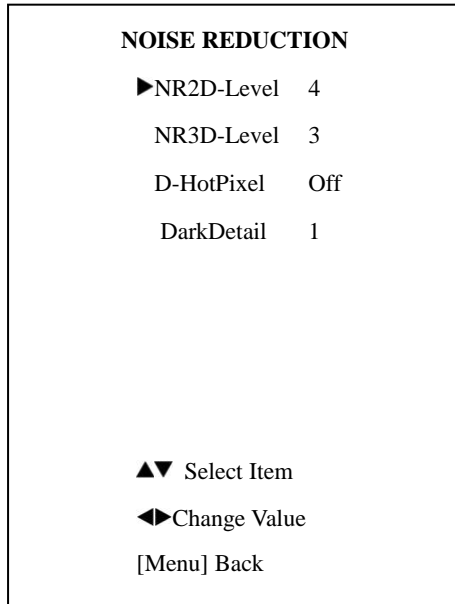

NR2D-Level: 2D noise reduction. Optional

items: Off, 1 ~ 5

NR3D-Level: 3D noise reduction. Optional items: Off, 1 ~ 5

D-HotPixel: Dynamic bad points, Optional items: Off, Auto, 1 ~ 5

Note:

D-HotPixel used to mask the part of the color pixels generated by the machine overheating.

DarkDetail: Shadow detail, Optional items: 0~15

Note:

The higher the noise reduction's level, the more of the image details lose.

## 7. SETUP

Move the cursor to the Setup item in the main menu and press [HOME] button, SETUP menu appears, as shown in the following figure.

<b>SETUP</b>	
▶Language	EN
ColorSys	YPbPr
DVIMode	DVI
Protocol	VISCA
Address	1
AddrFix	Off
Baudrate	9600
▲▼ Select Item	
◀▶ Change Value	
[Menu] Back	

Language: menu language, Optional items: EN, Chinese

ColorSys: Set the DVI system, color in the analog signal, Optional items: YPbPr, RGB (Only effective under 720 p60/1080 p60)

DVIMode: Set the output signal mode selection of DVI digital signal, Optional items: HDMI, DVI(Effect after restart)

Protocol: Control protocol type. Optional items: VISCA, P-D, P-P

Address: protocol address, To be decided according to the agreement, can be set up under the VISCA items: 1 ~ 7, P - P and P- D can be set up: 0 ~

254

AddrFix: If I can change through the serial port of infrared switch, Optional items: On, Off (When set to On, cannot address via a serial port to modify the camera)

Baudrate: Serial port baud rate. Optional items: 2400, 4800, 9600

## 8. RESTORE DEFAULT

Move the cursor to the Restore Default item in the main menu and press [HOME] button, RESTORE DEFAULT menu appears, as shown in the following figure.

<b>RESTORE DEFAULT</b>	
▶Restore?	No
◀▶ Change Value	
[Home] OK	
[Menu] Back	

---

Restore: Confirm restore factory settings.

Optional items: Yes, No

Note: Press [HOME] button to confirm.

## 9. EXIT

In the main menu and press [HOME] button, the following screen appears.

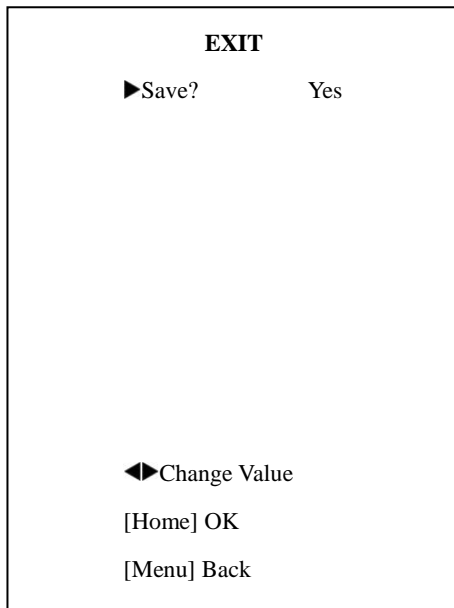

Save: Save Options. Optional items: Yes, No

Note: Press [HOME] button to confirm.

---

# Maintenance and Troubleshooting

## Camera Maintains

- If camera will not be used for a long time, please turn off the power switch, disconnect AC power cord of AC adaptor to the outlet.
- Use soft cloth or tissue to clean the camera cover.
- Please use the soft dry cloth to clean the lens. If the camera is very dirty, clean it with diluted neuter detergent. Do not use any type of solvents, which may damages the surface.

## Unqualified Application

- No shooting extreme bright object for a long period of time, such as sunlight, light sources, etc.
- No operating in unstable lighting conditions, otherwise image will be flickering.
- No operating close to powerful electromagnetic radiation, such as TV or radio transmitters, etc.

## Troubleshooting

### Image

- No image
  1. Check whether the power cord is connected, voltage is OK, POWER lamp is light.
  2. Check whether the camera can self-test after startup.
  3. Check the BOTTOM switch and make sure the two switches are both set OFF.
  4. Check video cable is connected correctly.
- Abnormal display of image

Check video cable is connected correctly.
- Image dithering even at wide zoom position
  1. Check whether camera is fixed correctly.
  2. Make sure if there are something like vibration machine or other things nearby.

---

## Control

- IR remote controller cannot control the camera
  1. Change the battery
  2. Check the camera working mode.
  3. Check IR address of the Remote Commander is set correctly.
  
- Serial communication cannot control the camera
  1. Check the camera working mode.
  2. Check control cable is connected correctly.

## Copyright Notice

The contents of this manual are copyrighted by InFocus Corporation. This document cannot be cloned, copied or translated without the permission of InFocus Corporation. Product specifications and information which is referred to in this document are for reference only, and the content may be updated at any time without prior notice.

2014.4