

INSTRUCTION SHEET
AX-SXR SERIES
ROTATING EQUIPMENT ACCESS SYSTEM

PATENT 5,443,312

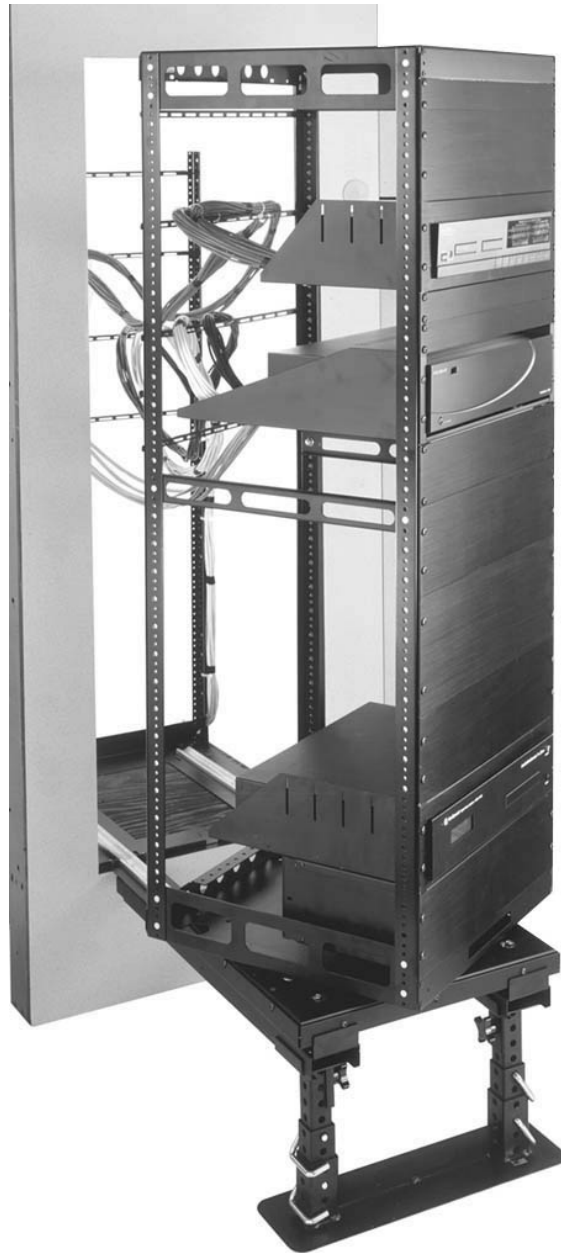

THANK YOU

Thank you for purchasing the AX-SXR Series Rotating Equipment Access System. Please read these instructions thoroughly before installing / assembling this product.

PRODUCT FEATURES

- Slides out and rotates for access to cables and rear equipment connections
- Allows installation of equipment flush into a wall or cabinet
- Removable rack frame can be integrated off-site to save time

IMPORTANT SAFETY INSTRUCTIONS

- Read these instructions.
- Keep these instructions.
- Heed all warnings.
- Follow all instructions.
- Clean only with dry cloth.
- Only use attachments/accessories specified by the manufacturer.



WARNING: A WARNING ALERTS YOU TO A SITUATION THAT COULD RESULT IN SERIOUS PERSONAL INJURY OR DEATH.



CAUTION: A CAUTION ALERTS YOU TO A SITUATION THAT MAY RESULT IN MINOR PERSONAL INJURY OR DAMAGE TO THE PRODUCT AND / OR PROPERTY.

NOTE: A NOTE is used to highlight procedures pertaining to the installation, operation or maintenance of the product.

IMPORTANT WARNINGS AND CAUTIONS!



WARNING! FAILURE TO READ, UNDERSTAND AND FOLLOW THE FOLLOWING INFORMATION CAN RESULT IN SERIOUS PERSONAL INJURY, DAMAGE TO THE EQUIPMENT OR VOIDING OF THE WARRANTY. IT IS THE RESPONSIBILITY OF THE INSTALLER/USER TO ENSURE THAT THIS PRODUCT IS LOADED ACCORDING TO SPECIFICATIONS.



WARNING! THE WEIGHT RATINGS OF THIS PRODUCT CAN BE FOUND ON THE PRODUCT. EXCEEDING THESE WEIGHT RATINGS CAN RESULT IN SERIOUS INJURY OR DAMAGE TO THE EQUIPMENT. IT IS THE RESPONSIBILITY OF THE INSTALLER/USER TO ENSURE ALL COMPONENTS INSTALLED DO NOT SURPASS THE WEIGHT RATINGS AS AN UNSTABLE CONDITION CAN OCCUR WHICH MAY CAUSE POSSIBLE INJURY OR DAMAGE.



CAUTION! IF THERE IS VISIBLE DAMAGE ON THE PRODUCT IT MUST NOT BE INSTALLED.



CAUTION! SAFETY MEASURES MUST BE PRACTICED AT ALL TIMES DURING THE ASSEMBLY OF THIS PRODUCT. USE PROPER SAFETY EQUIPMENT AND TOOLS FOR THE ASSEMBLY PROCEDURE TO PREVENT PERSONAL INJURY.



CAUTION! NOTE THAT DURING CONSTRUCTION OF THE CONSOLE, THERE MUST BE NO POSSIBILITY OF PERSONAL INJURY, FOR EXAMPLE THE SQUEEZING OF FINGERS OR ARMS.



CAUTION! FOR LOADING, ALWAYS PUT HEAVIER ITEMS AT THE BOTTOM OF THE BAYS, NOT NEAR THE TOP, IN ORDER TO HELP PREVENT THE POSSIBILITY OF THE FURNISHING TIPPING OVER.



CAUTION! THE APPLIANCE IS NOT INTENDED FOR USE BY YOUNG CHILDREN OR INFIRM PERSONS WITHOUT SUPERVISION.

TABLE OF CONTENTS

Important Safety Instructions.....	3
Rough-In / Site Preparation.....	5
Millwork Requirements.....	6
Rack Assembly.....	7
Rack Assembly (Continued).....	8
Rack Assembly (Continued).....	9
Service Stand / Service Track Assembly.....	10
Rack and Cable Carrier Installation / Cable Management.....	11
Securing Rack Assembly In Millwork.....	12
Warranty.....	13

ROUGH-IN / SITE PREPARATION

1) Rough-in millwork must be plumb, square and completed before beginning assembly. Refer to millwork mounting requirements below.

	WIDTH	DEPTH	SETBACK
MINIMUM	9 1/4"	25 1/2"	1/2"
MAXIMUM	9 1/4"	27 1/2"	2 1/2"

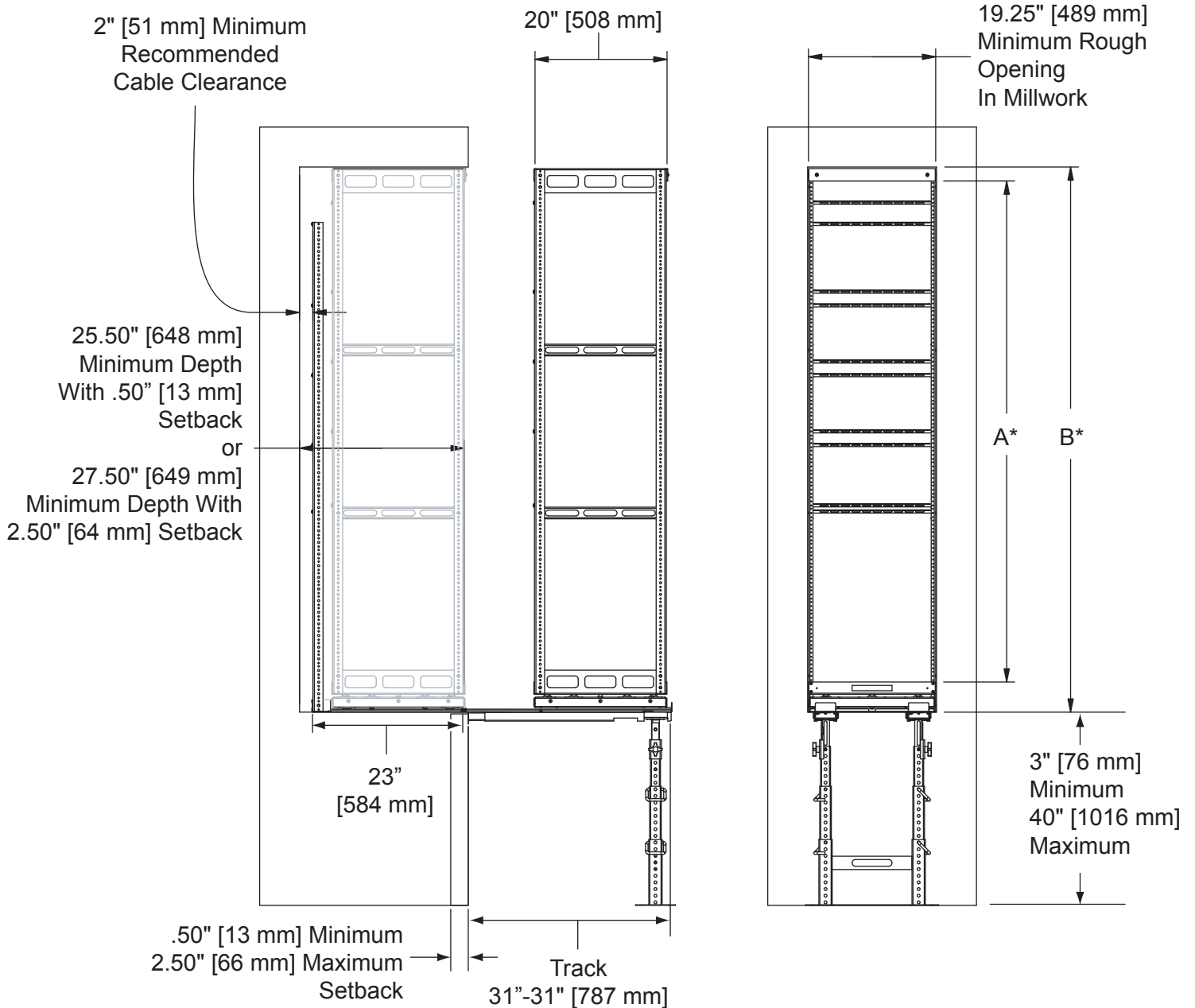

* Refer to following page for specific model height requirements.

NOTE: The millwork must be constructed in such a manner as to provide a weight capacity greater than the total assembled weight.

MILLWORK REQUIREMENTS

	NUMBER OF USABLE RACKSPACES	"A" USABLE RACK HEIGHT	"B" ROUGH OPENING HEIGHT
AX-SXR-15	15	26-1/4 [667]	33 [838]
AX-SXR-16	16	28 [711]	34-3/4 [883]
AX-SXR-17	17	29-3/4 [756]]36-1/2 [927]
AX-SXR-18	18	31-1/2 [800]	38-1/4 [972]
AX-SXR-19	19	33-1/4 [845]	40 [1016]
AX-SXR-20	20	35 [889]	41-3/4 [1060]
AX-SXR-21	21	36-3/4 [933]	43-1/2 [1105]
AX-SXR-22	22	38-1/2 [978]	45-1/4 [1149]
AX-SXR-23	23	40-1/4 [1022]	47 [1194]
AX-SXR-24	24	42 [1067]	48-3/4 [1238]
AX-SXR-25	25	43-3/4 [1111]	50-1/2 [1283]
AX-SXR-26	26	45-1/2 [1156]	52-1/4 [1327]
AX-SXR-27	27	47-1/4 [1200]	54 [1372]
AX-SXR-28	28	49 [1245]	55-3/4 [1416]
AX-SXR-29	29	50-3/4 [1289]	57-1/2 [1461]
AX-SXR-30	30	52-1/2 [1334]	59-1/4 [1505]
AX-SXR-31	31	54-1/4 [1378]	61 [1549]
AX-SXR-32	32	56 [1422]	62-3/4 [1594]
AX-SXR-33	33	57-3/4 [1467]	64-1/2 [1638]
AX-SXR-34	34	59-1/2 [1511]	66-1/4 [1683]
AX-SXR-35	35	61-1/4 [1556]	68 [1727]
AX-SXR-36	36	63 [1600]	69-3/4 [1772]
AX-SXR-37	37	64-3/4 [1645]	71-1/2 [1816]
AX-SXR-38	38	66-1/2 [1689]	73-1/4 [1861]
AX-SXR-39	39	68-1/4 [1734]	75 [1905]
AX-SXR-40	40	70 [1778]	76-3/4 [1949]
AX-SXR-41	41	71-3/4 [1822]	78-1/2 [1994]
AX-SXR-42	42	73-1/2 [1867]	80-1/4 [2038]
AX-SXR-43	43	75-1/4 [1911]	82 [2083]

NOTE: Total rack height including rough-in pan is the usable rack height ("A") plus 4-9/16."

RACK ASSEMBLY

- 1) Align the (4) pre-installed mounting studs on each rackrail with mounting holes in top and bottom frames. **(FIGURE A)**
- 2) Loosely secure each rackrail to top and bottom frame using (2) 5/16" flange nuts per frame. **(FIGURE A)**

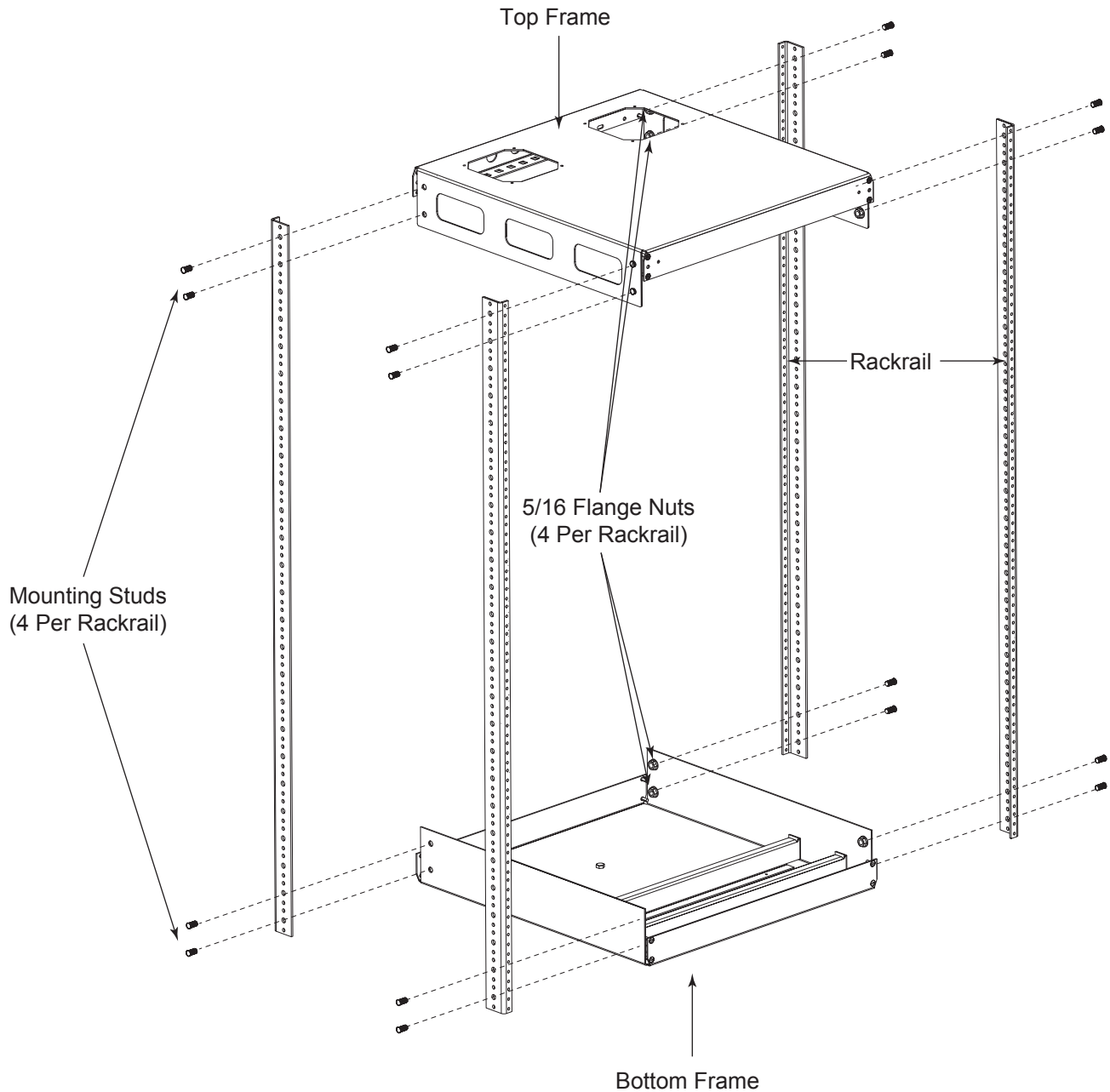

FIGURE A

RACK ASSEMBLY (Continued)

- 3) Install (4) 10-32 Hex Head screws through top and bottom frames into each rackrail. **(FIGURE B)**
- 4) Install (2) squaring panels on front and rear of assembly using (4) 10-32 x 1/4" screws. Locate squaring panels at the mid-point of rackrail assembly. **(FIGURE B)**
- 5) If supplied, install (2) support brackets on pre-installed rackrail mounting studs using (2) 10-32 hex head screws per bracket. **(FIGURE B)**
- 6) Lay assembly on a flat, level surface and square frame on all four corners. **(FIGURE C)**
- 7) Tighten all flange nuts.

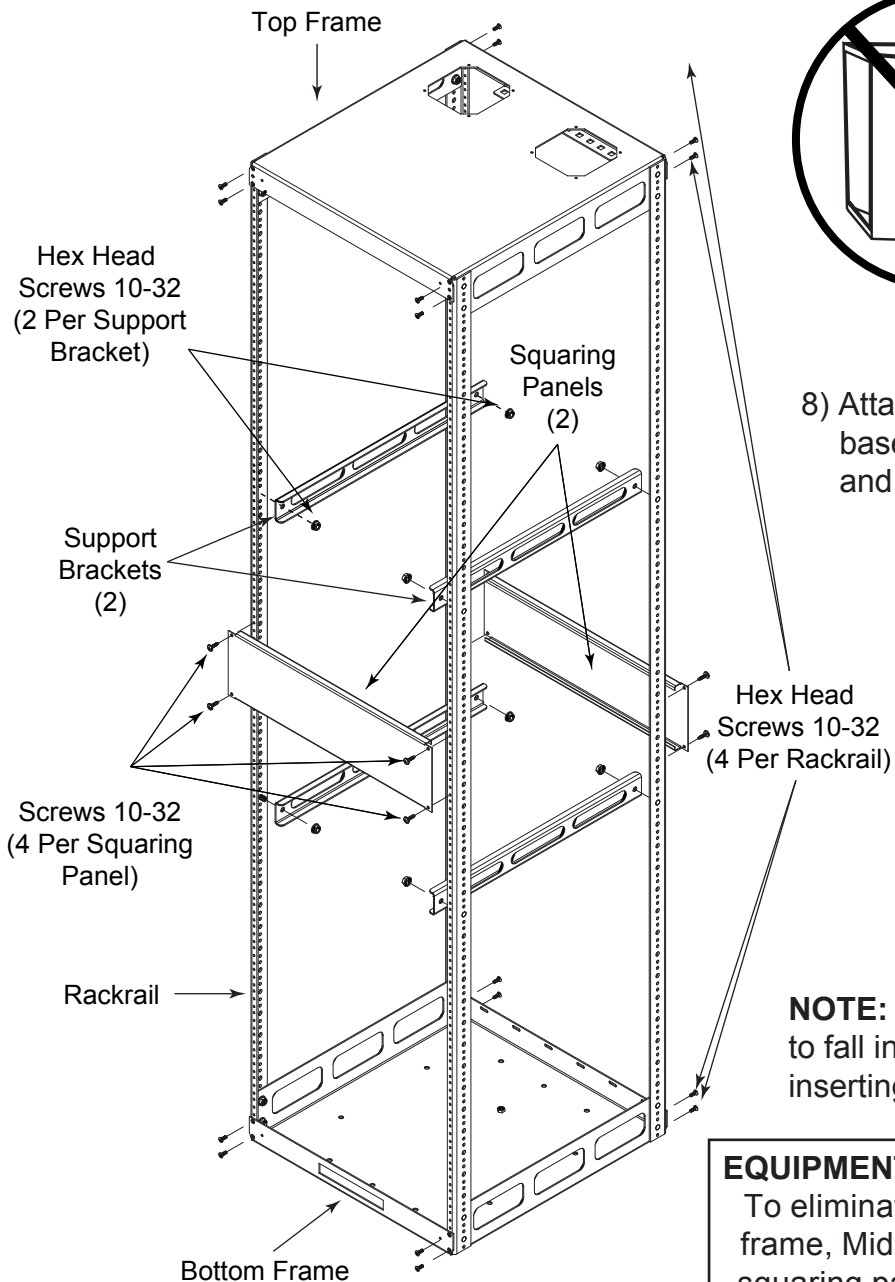

FIGURE B

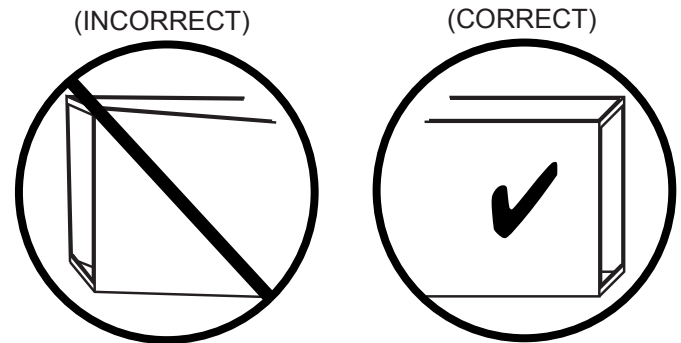

FIGURE C

- 8) Attach the bottom of the rack to the roller base using the 1/2" shoulder screw provided and tighten. **(FIGURE D)**

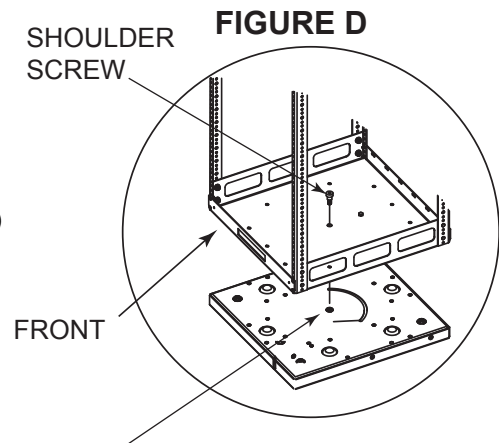

FIGURE D

NOTE: The stud on the bottom of the rack needs to fall into the slot on the roller base before inserting the shoulder screw.

EQUIPMENT LOADING AND SQUARING PANELS

To eliminate the possibility of a center bow in the frame, Middle Atlantic Products suggests that the squaring panels be left in place until some of your components have been mounted.

RACK ASSEMBLY (Continued)

8) Install top trim panel using (2) 10-32 x 1/4" screws. **(FIGURE E)**

NOTE: Top trim panel contains only two screw holes.

9) If equipped, align the edge of the lacer bars with the outside edge of the rackrail and ensure that the flat side of the lacer bar is on top. Install the lacer bars as shown using 10-32 Phillips head screws. **(FIGURE F)**

NOTE: The lacer bars should not be placed in the bottom 8 rackspaces. The lacer bars on the rack should be 2 rackspace above or below the corresponding lacer bars on the rough-in pan.

TIP: When installing the lacer bars on the rough-in pan, place the rack with the roller base on the rough-in pan and mount the equipment in the rack and position the lacer bars as needed. This will simplify cable management once the rough-in pan is mounted into the millwork. **(FIGURE G)**

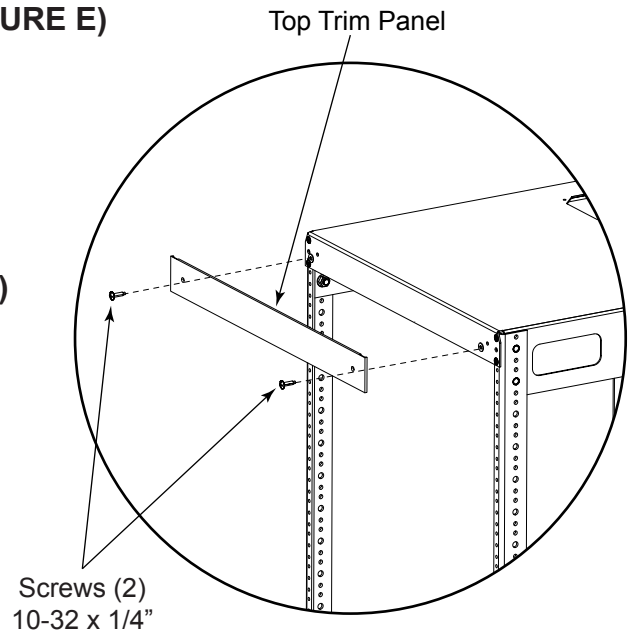

FIGURE E

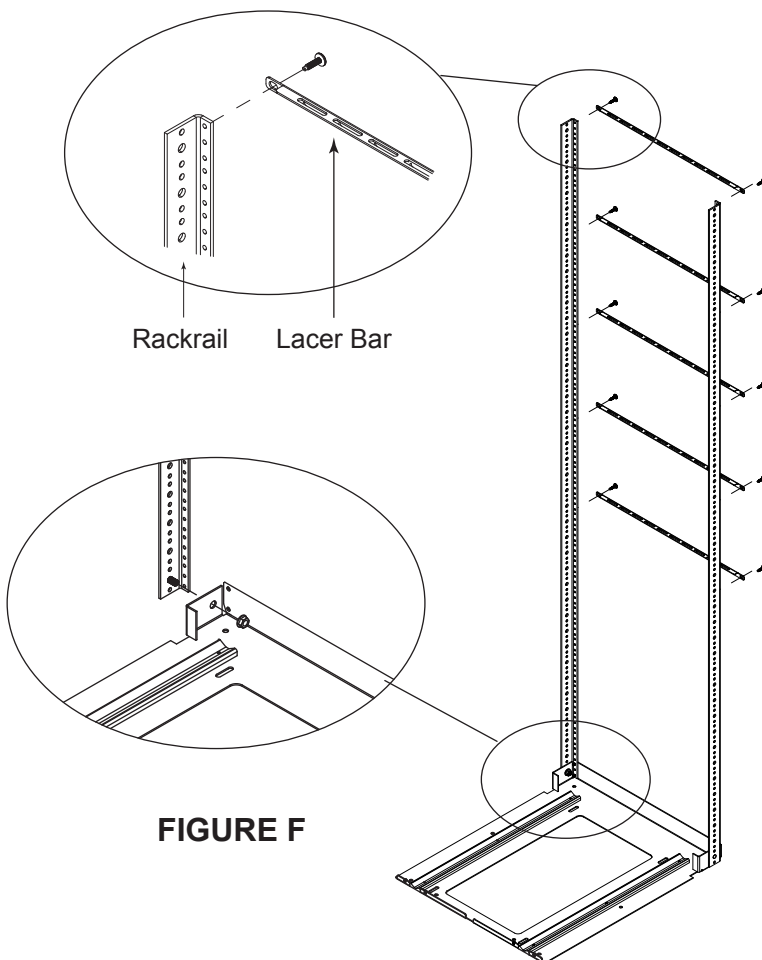

FIGURE F

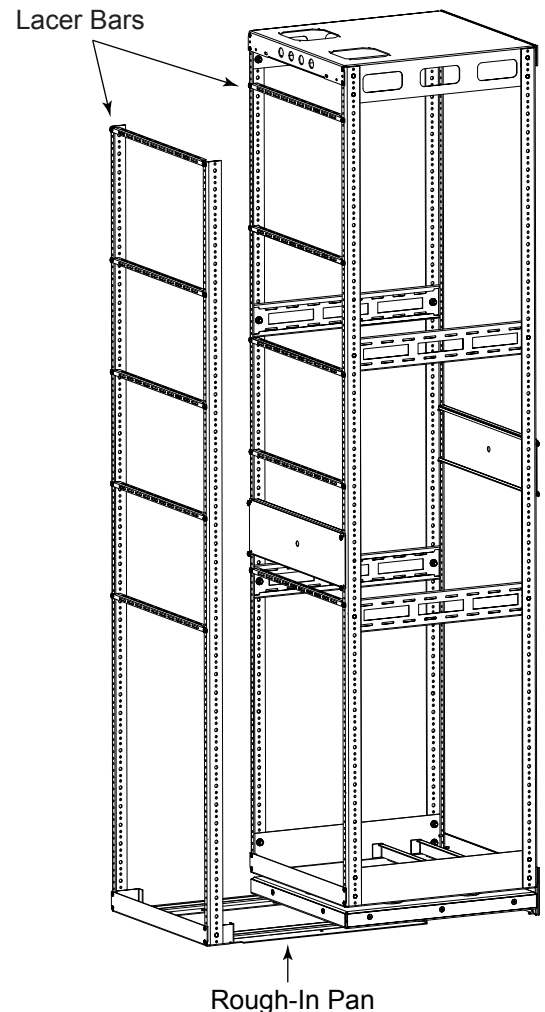

FIGURE G

SERVICE STAND / SERVICE TRACK ASSEMBLY

- 1) Assemble service stand as per instructions included with unit.
- 2) Adjust stand to approximate height of rough-in pan. **(FIGURE H)**
- 3) Position notched end of each service track on service stand saddles. **(FIGURE H)**

CAUTION! Be sure notched ends are fully seated in service stand saddles to prevent tracks from falling out.

- 4) Position opposite end of each service track on millwork. **(FIGURE H)**
- 5) Secure each service track to rough-in pan using (2) 10-32 hex head screws (included in service track hardware kit). **(FIGURE I)**

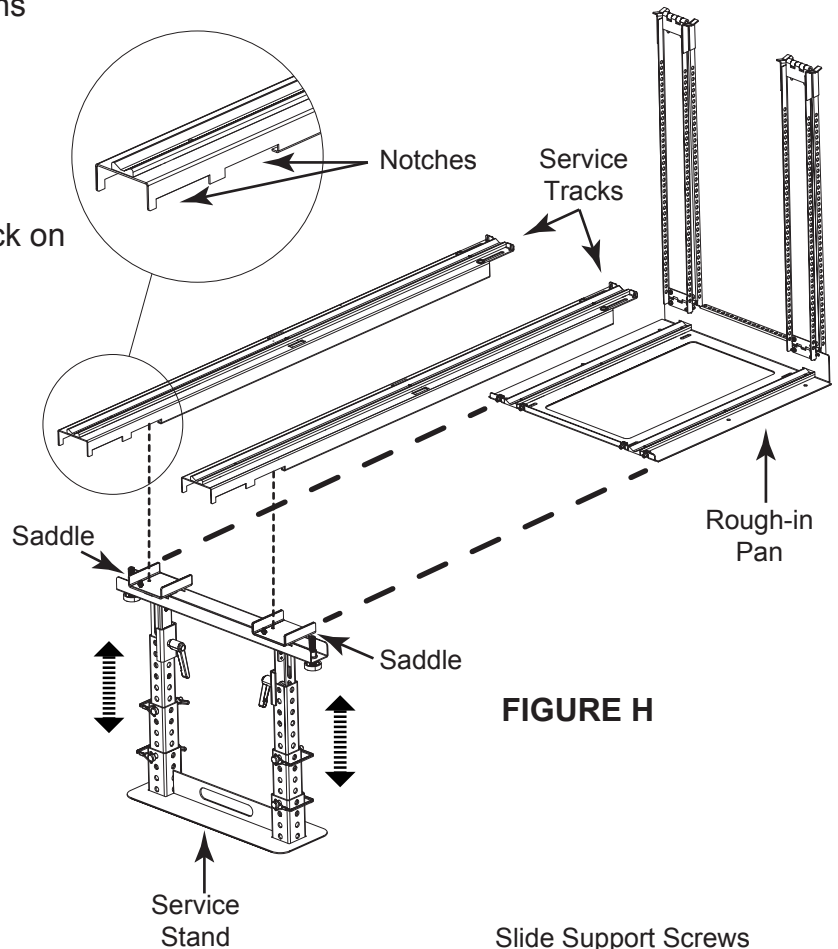
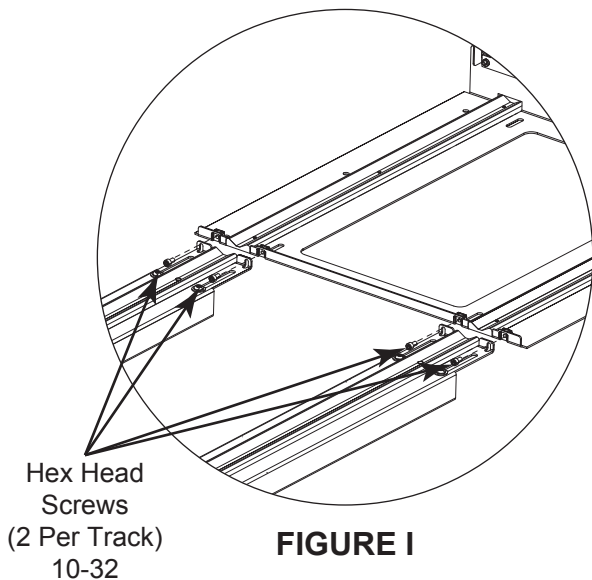

FIGURE H



- 6) Fine adjust the service stand with the aid of the level installed in the service tracks.
- 7) Extend slide supports on each service track to meet millwork using slide support screws (2 per service track). **(FIGURE J)**

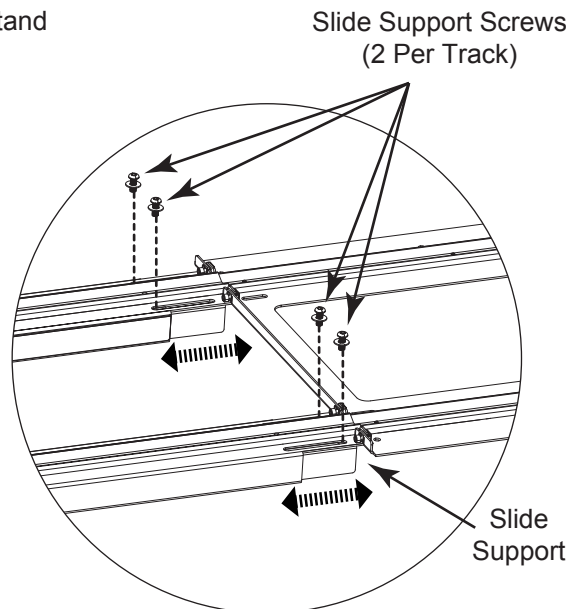

FIGURE J

NOTE: This adjustment strengthens track when extending heavy equipment for servicing.

RACK INSTALLATION / CABLE MANAGEMENT

1) Place rack on service track assembly (observe proper front/rear orientation). **(FIGURE K)**

⚠ CAUTION! Do not allow the frame to roll off end of tracks.

NOTE: Determine which direction the rack will rotate before beginning cable management.

2) Select one side of the rack for signal cables, and the opposite side for power cables. Extend the rack and rotate 60° as shown. Lace the cables as shown, ensuring that the cables are taut. This ensures that the service loop will be the correct length and not be pinched when closing the rack. **(FIGURE L)**

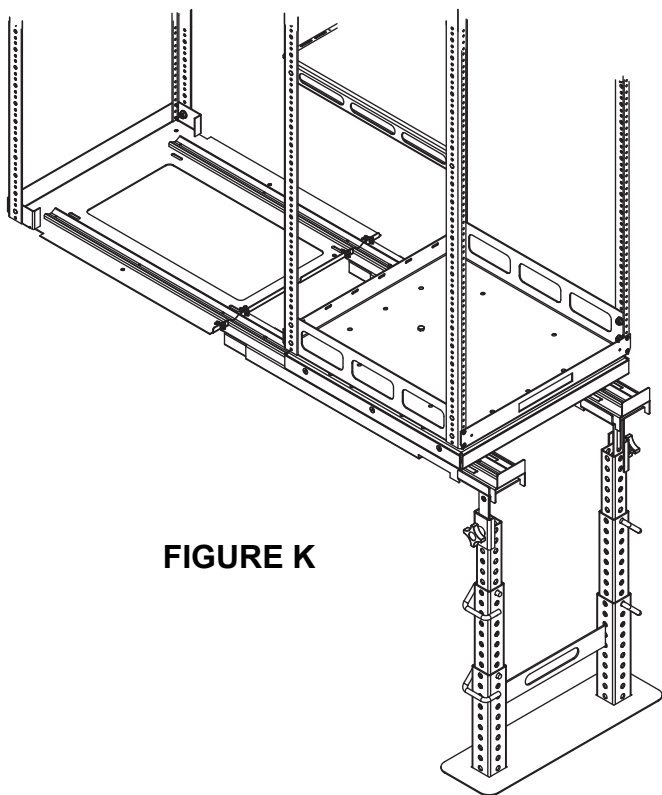

FIGURE K

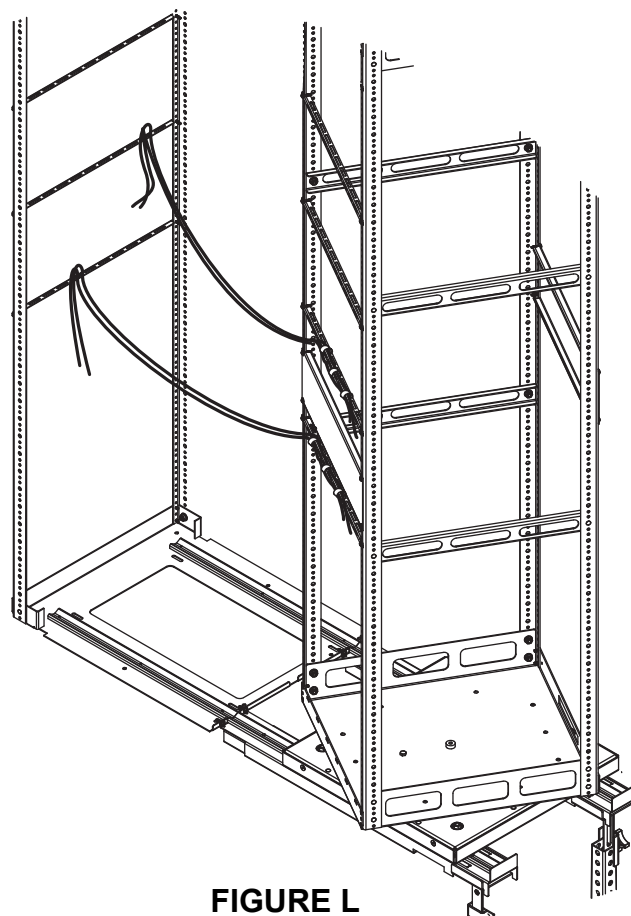

FIGURE L

SECURING RACK ASSEMBLY IN MILLWORK

- 1) Roll loaded rack into millwork.
- 2) Install bottom trim panel using (4) 10-32 Phillips head screws (included in hardware kit). **(FIGURE M)**

⚠ WARNING! The trim panel is integral to the safe operation of this product and is required to prevent the rack from sliding out. Failure to install trim panel can result in serious damage to equipment and/or risk of injury.

- 3) Remove tracks and service stand.

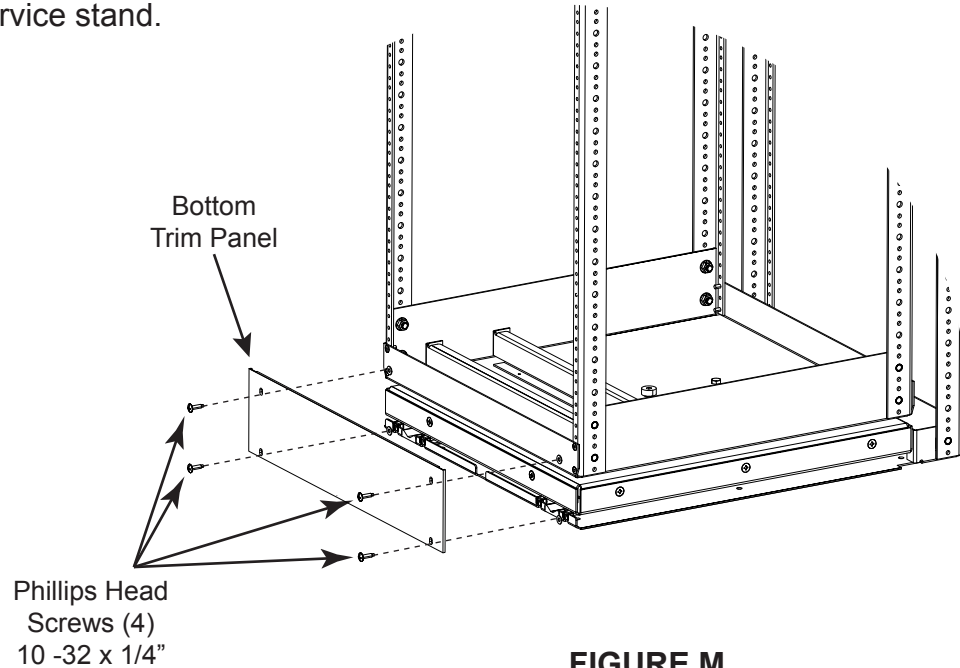

FIGURE M

NOTE: If the loaded rack frame springs outward during installation, it can be secured directly to the millwork wherever a blank panel is located. With rack closed, remove blank panel and install customer-supplied screws through each side of front rackrail into millwork. **(FIGURE N)**

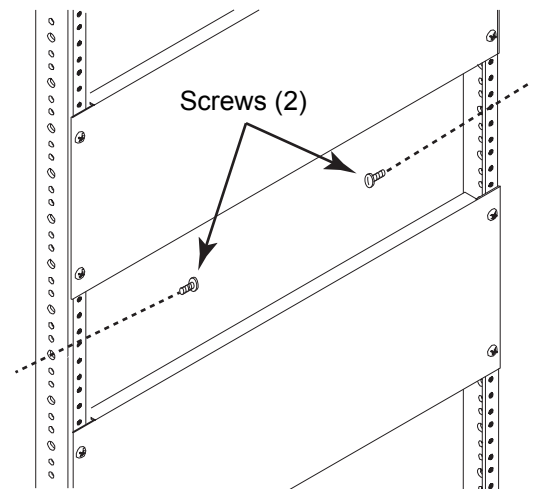

FIGURE N

WARRANTY

Middle Atlantic Products (the "Company") warrants the AX-SXR Rotating Equipment Access System to be free from defects in material or workmanship under normal use and conditions for a period of (3) years from the date of shipment by the company.

The Company's entire liability to the purchaser, and the purchaser's (or any other party's) sole and exclusive remedy, under this warranty shall be limited, at the Company's option, to either (a) return of and refund of the price paid for, or (b) repair or replacement at the Company's factory of the products purchased, or any part or parts thereof, which the Company has determined to be defective after inspection thereof at the Company's factory.

This warranty does not cover damage due to acts of God, accident, misuse, abuse or negligence by parties other than the Company, or any modification or alteration of the products. In addition, this warranty does not cover damage due to improper handling, assembly, installation or maintenance.

THIS WARRANTY IS IN LIEU OF ALL OTHER WARRANTIES OF ANY KIND, EITHER EXPRESSED OR IMPLIED, INCLUDING, BUT NOT LIMITED TO, IMPLIED WARRANTIES OF MERCHANTABILITY AND FITNESS FOR A PARTICULAR PURPOSE.

TO THE MAXIMUM EXTENT PERMITTED BY APPLICABLE LAW, IN NO EVENT SHALL THE COMPANY BE LIABLE FOR ANY SPECIAL, INCIDENTAL, INDIRECT, OR CONSEQUENTIAL DAMAGES WHATSOEVER (INCLUDING, WITHOUT LIMITATION, DAMAGES FOR LOSS OF BUSINESS PROFITS, BUSINESS INTERRUPTION OR ANY OTHER PECUNIARY LOSS) ARISING OUT OF THE USE OF THE PRODUCTS PURCHASED, EVEN IF THE COMPANY HAS BEEN ADVISED OF THE POSSIBILITY OF SUCH DAMAGES. THE COMPANY'S LIABILITY TO THE PURCHASER (OR ANY OTHER PARTY) HEREUNDER, IF ANY, SHALL IN NO EVENT EXCEED THE PURCHASE PRICE OF THE PRODUCTS PAID TO THE COMPANY.

Corporate Headquarters

Corporate Voice 973-839-1011 - Fax 973-839-1976
International Voice +1 973-839-8821 - Fax +1 973-839-4982
middleatlantic.com - info@middleatlantic.com

Middle Atlantic Canada

Voice 613-836-2501 - Fax 613-836-2690
middleatlantic.ca - customerservicecanada@middleatlantic.ca

Factory Distribution

USA: NJ - CA - IL Canada: ON - BC

At Middle Atlantic Products we are always listening. Your comments are welcome.

Middle Atlantic Products is an ISO 9001 and ISO 14001 Registered Company.