

INSTALLATION INSTRUCTIONS

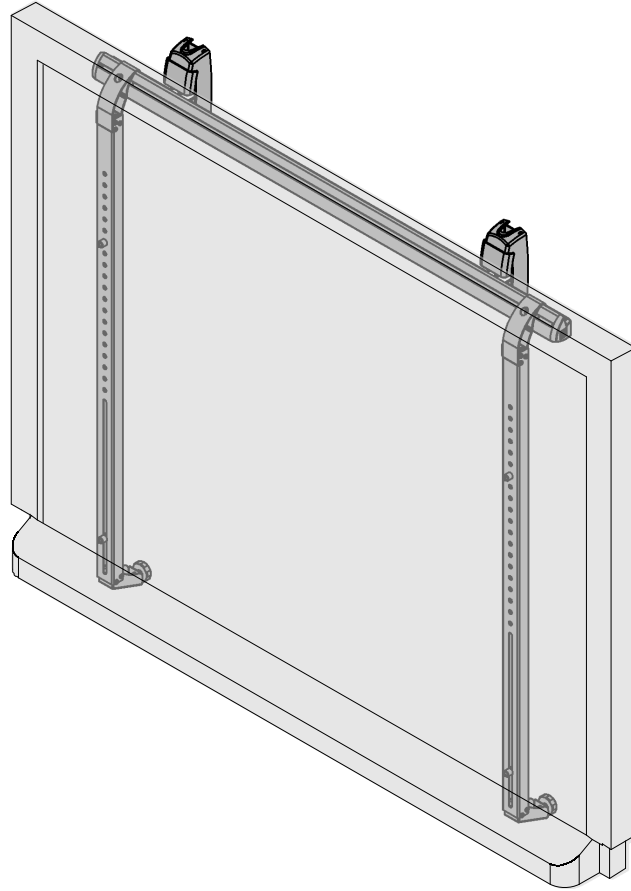

Interactive Whiteboard Mount

DISCLAIMER

Milestone AV Technologies and its affiliated corporations and subsidiaries (collectively "Milestone"), intend to make this manual accurate and complete. However, Milestone makes no claim that the information contained herein covers all details, conditions or variations, nor does it provide for every possible contingency in connection with the installation or use of this product. The information contained in this document is subject to change without notice or obligation of any kind. Milestone makes no representation of warranty, expressed or implied, regarding the information contained herein. Milestone assumes no responsibility for accuracy, completeness or sufficiency of the information contained in this document.

Chief® is a registered trademark of Milestone AV Technologies. All rights reserved.



IMPORTANT SAFETY INSTRUCTIONS



WARNING: A WARNING alerts you to the possibility of serious injury or death if you do not follow the instructions.



CAUTION: A CAUTION alerts you to the possibility of damage or destruction of equipment if you do not follow the corresponding instructions.



WARNING: Failure to read, thoroughly understand, and follow all instructions can result in serious personal injury, damage to equipment, or voiding of factory warranty! It is the installer's responsibility to make sure all components are properly assembled and installed using the instructions provided.



WARNING: Failure to provide adequate structural strength for this component can result in serious personal injury or damage to equipment! It is the installer's responsibility to make sure the structure to which this component is attached can support five times the combined weight of all equipment. Reinforce the structure as required before installing the component. The wall to which the mount is being attached may have a maximum drywall thickness of 5/8" (wood stud or concrete installations).



WARNING: Exceeding the weight capacity can result in serious personal injury or damage to equipment! It is the installer's responsibility to make sure the combined weight of all components located on the WBM2 does not exceed 125 lbs (56.7 kg).



WARNING: Use this mounting system only for its intended use as described in these instructions. Do not use attachments not recommended by the manufacturer.



WARNING: Never operate this mounting system if it is damaged. Return the mounting system to a service center for examination and repair.



WARNING: Do not use this product outdoors.

IMPORTANT ! : The WBM2 has been designed to be mounted onto either a 2" x 4" wood stud wall, or an 8" concrete wall, 8" x 8" x 16" concrete block or clay brick wall.





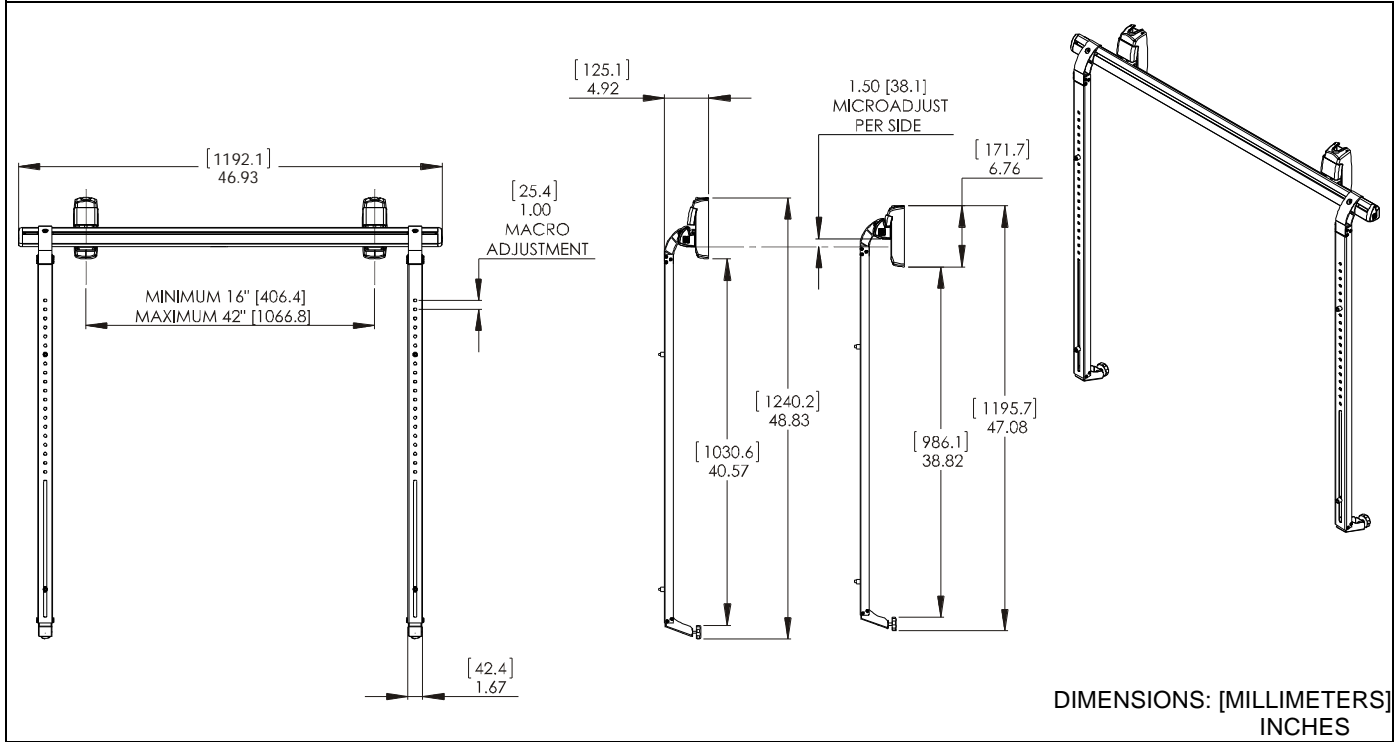

NOTE: The WBM2 may be used with UL Listed accessories WBAU or WBAE.

--SAVE THESE INSTRUCTIONS--

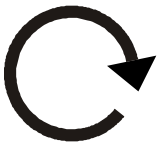
DIMENSIONS

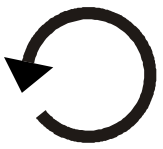

LEGEND

	Tighten Fastener Apretar elemento de fijación Befestigungsteil festziehen Apertar fixador Serrare il fissaggio Bevestiging vastdraaien Serrez les fixations		Pencil Mark Marcar con lápiz Stiftmarkierung Marcar com lápis Segno a matita Potloodmerkten Marquage au crayon
	Loosen Fastener Aflojar elemento de fijación Befestigungsteil lösen Desapertar fixador Allentare il fissaggio Bevestiging losdraaien Desserrez les fixations		Drill Hole Perforar Bohrloch Fazer furo Praticare un foro Gat boren Percez un trou
	Phillips Screwdriver Destornillador Phillips Kreuzschlitzschraubendreher Chave de fendas Phillips Cacciavite a stella Kruiskopschroevendraaier Tournevis à pointe cruciforme		Hex-Head Wrench Llave de cabeza hexagonal Sechskantschlüssel Chave de cabeça sextavada Chiave esagonale Zeskantsleutel Clé à tête hexagonale
	Open-Ended Wrench Llave de boca Gabelschlüssel Chave de bocas Chiave a punte aperte Steeksleutel Clé à fourche		

TOOLS REQUIRED FOR INSTALLATION



PARTS

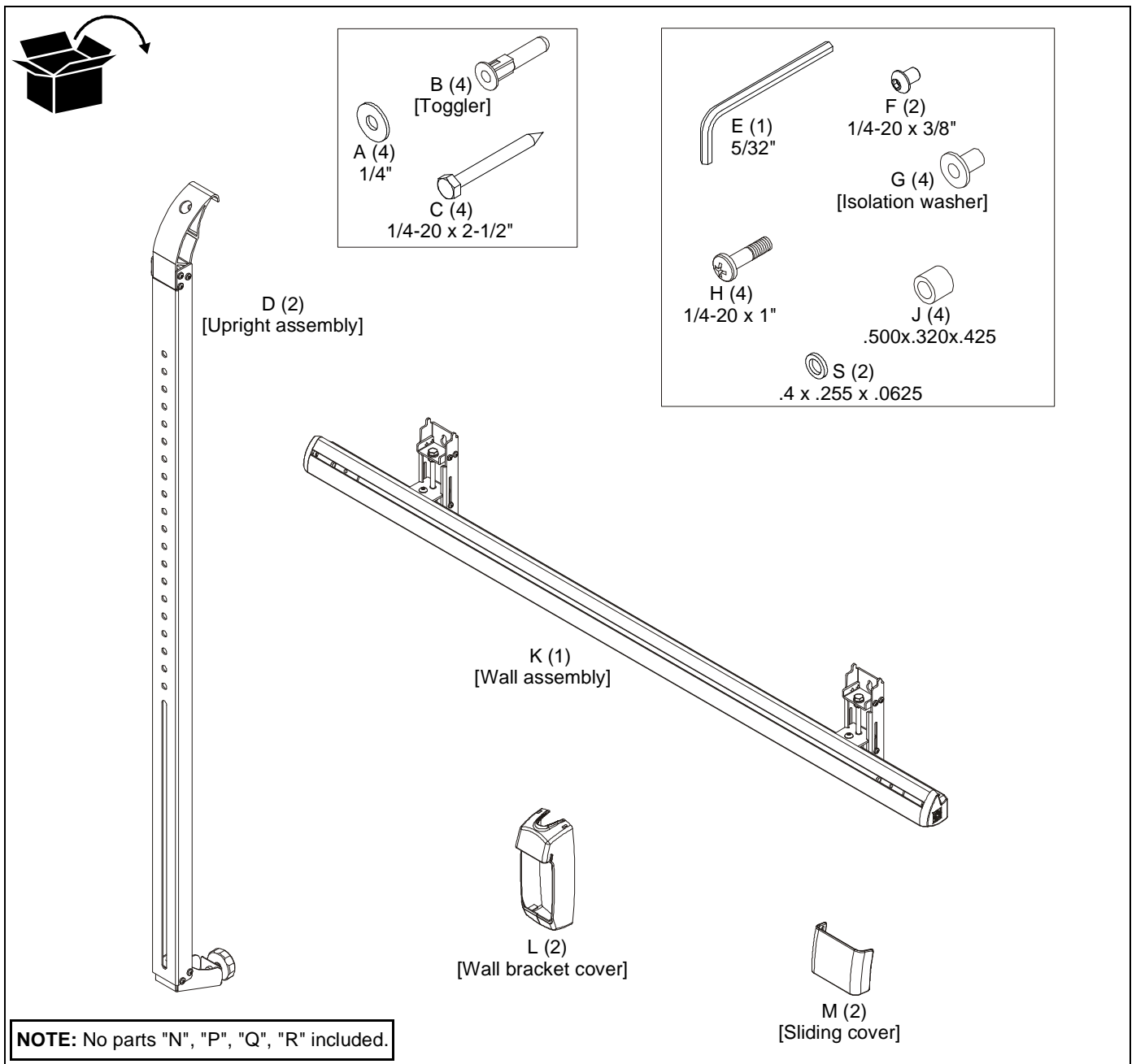

ASSEMBLY AND INSTALLATION

The WBM2 will allow an interactive whiteboard to be installed over an existing chalkboard or whiteboard. The WBM2 may be installed in the default position which installs in front of preexisting chalk or marker trays, OR in the low profile position which installs on the top of preexisting chalk or marker trays.

Locate Mounting Site



WARNING: IMPROPER INSTALLATION CAN LEAD TO MOUNT FALLING CAUSING SEVERE PERSONAL INJURY OR DAMAGE TO EQUIPMENT! It is the installers responsibility to make certain the structure to which the mount is being attached is capable of supporting five times the weight of the WBM2 and all attached equipment not to exceed 125 lbs (56.7 kg).



WARNING: ELECTRICAL SHOCK, EXPLOSION AND FIRE HAZARD! CUTTING OR DRILLING INTO ELECTRICAL CORDS, CABLES OR GAS PLUMBING CAN CAUSE DEATH OR SERIOUS PERSONAL INJURY! ALWAYS make certain area behind mounting surface is free of electrical wires, cables, gas, water, waste, or any other plumbing before drilling or installing fasteners.

Adjusting Wall Brackets for Installation

NOTE: The wall brackets on the wall assembly may be adjusted to suit installation needs, but must be spaced a **minimum** of 16" (406.4mm) apart.

1. Slide wall brackets along wall assembly (K). (See Figure 1)
2. Tighten button head cap screw on each wall bracket to secure wall brackets to wall assembly. (See Figure 1)

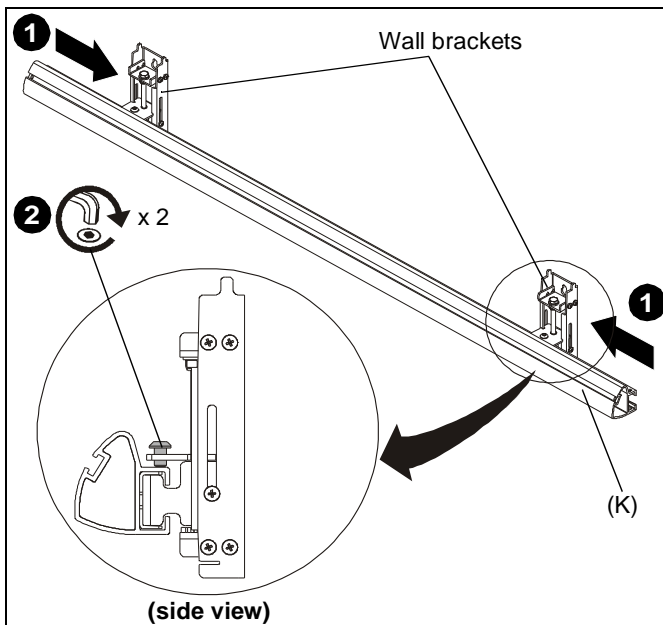

Figure 1

NOTE: Proceed to the **Installing to a Wood Stud Wall** section, or the **Installing to a Concrete, Concrete Block or Clay Brick Wall** section, as appropriate.

Installing to a Wood Stud Wall

1. Determine the center of the chalkboard.
2. Locate the closest 2" x 4" wood stud to the left and right of the selected location.

NOTE: The two WBM2 wall brackets on the wall assembly (K) must be mounted a minimum of 16" (406.4mm) apart, or a maximum of 42" (1066.8mm) apart.

3. Using a level, mark the wall on each stud above existing chalkboard through **top** mounting hole in the wall assembly (K). (See Figure 2)
4. Drill one 1/8" pilot hole in each stud. (See Figure 2)
5. Use two 1/4-20 x 2-1/2" lag bolts (C) and two 1/4" flat washers (A) to attach wall assembly (K) to wall. (See Figure 2)
6. Mark the wall through the **lower** mounting hole in the wall assembly (K). (See Figure 2)
7. Drill one 1/8" pilot hole in each stud through lower mounting hole in wall assembly (K). (See Figure 2)
8. Use two 1/4-20 x 2-1/2" lag bolts (C) and two 1/4" flat washers (A) to attach wall assembly (K) to wall. (See Figure 2)

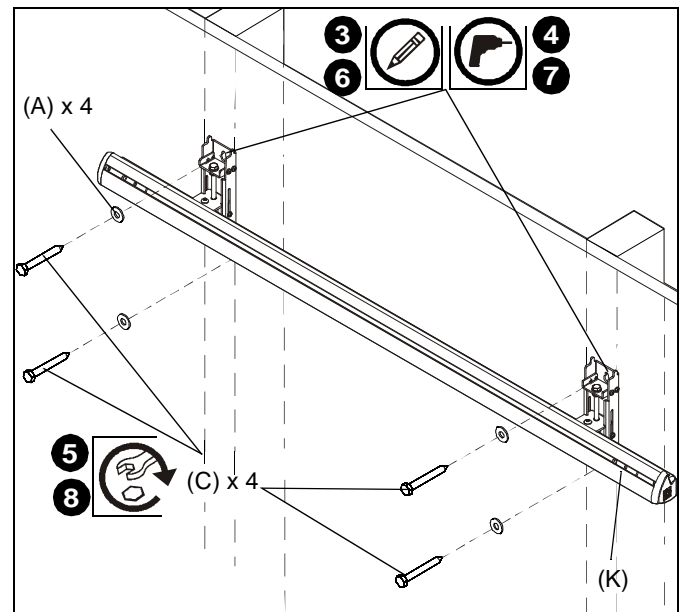

Figure 2

Installing to a Concrete, Concrete Block or Clay Brick Wall

NOTE: The WBM2 may be attached to an 8" concrete wall, 8" x 8" x 16" concrete block wall or clay brick wall.

1. Determine the center of the chalkboard.

NOTE: The two WBM2 wall brackets on the wall assembly (K) must be mounted a minimum of 16" (406.4mm) apart, or a maximum of 42" (1066.8mm) apart.

- Using a level, mark the wall above existing chalkboard through top mounting hole in the wall assembly (K). (See Figure 3)

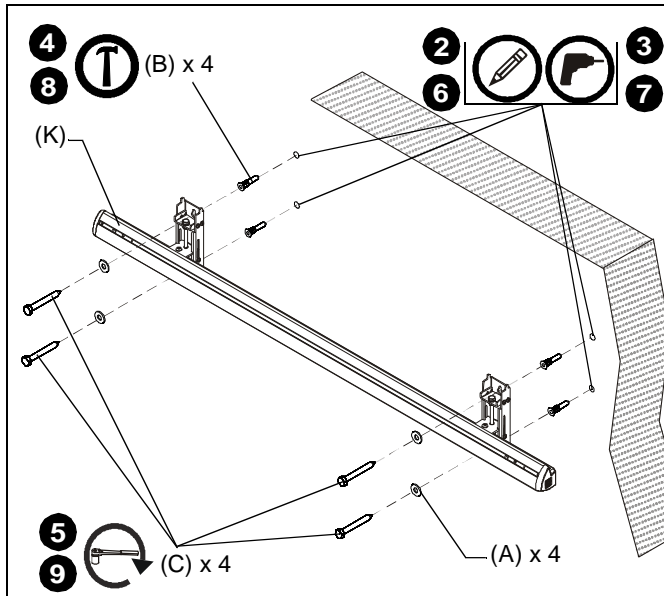

Figure 3

- Drill one 1/4" x 2-3/4" pilot hole at each marking. (See Figure 3)
- Install a toggler (B) into both pilot holes using a hammer. (See Figure 3)
- Use two 1/4-20 x 2-1/2" lag bolts (C) and two 1/4" flat washers (A) to attach wall assembly (K) to anchors in wall. (See Figure 3)
- Mark the wall through the lower mounting hole in the wall assembly (K). (See Figure 3)
- Drill one 1/4" x 2-3/4" pilot hole at each marking through lower mounting hole in wall assembly (K). (See Figure 3)
- Install a toggler (B) into both pilot holes using a hammer. (See Figure 3)
- Use two 1/4-20 x 2-1/2" lag bolts (C) and two 1/4" flat washers (A) to attach wall assembly (K) to anchors in wall. (See Figure 3)

Attaching Interactive Whiteboard

- Attach upright assembly (D) to back of white board using four 1/4-20 x 1" Phillips pan head screws (H), four isolation washers (G) and four .500"x.320"x.425" spacers (J). (See Figure 4)
- Repeat for second upright assembly. (See Figure 4)

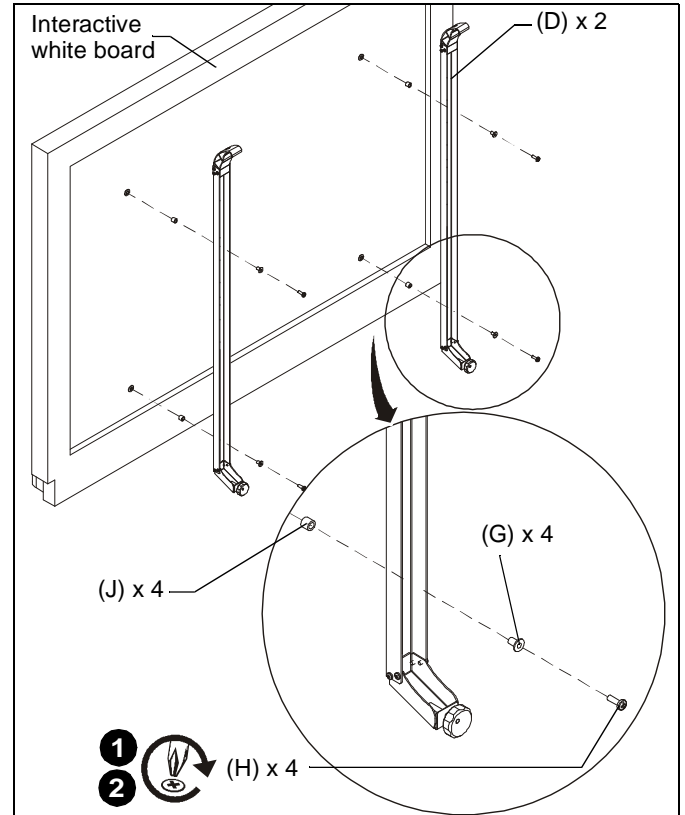

Figure 4

Attaching Uprights to Wall Extrusion

- Hook whiteboard with attached uprights onto the wall assembly (K). (See Figure 5)
- Move the slide nut so that it is aligned with the upright (D). (See Figure 5)
- Fasten upright in place using one 1/4-20 x 3/8" button head cap screw (F) and one .4"x.255"x.0625" nylon spacer (S). (See Figure 5)
- Repeat for other side of wall extrusion.

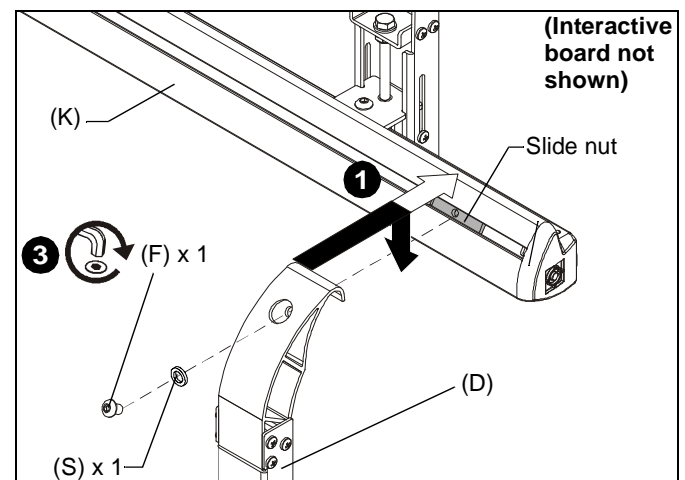

Figure 5

Adjustments

Lateral Movement

1. Loosen one button head cap screw at top of upright assembly (D). (See Figure 6)
2. Slide upright assembly left or right on wall assembly (K), as necessary. (See Figure 6)
3. Tighten button head cap screw to fasten upright assembly into place. (See Figure 6)

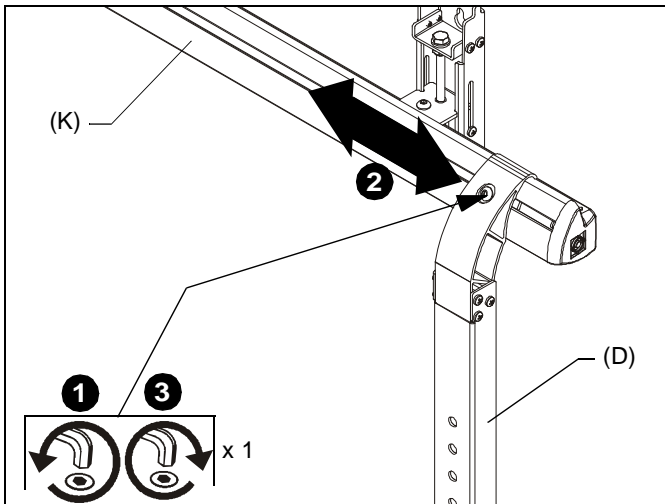

Figure 6

Vertical Adjustment

1. Loosen one button head cap screw with spacer at top of each upright assembly (D). (See Figure 7)
2. Unhook whiteboard from wall assembly (K). (See Figure 7)

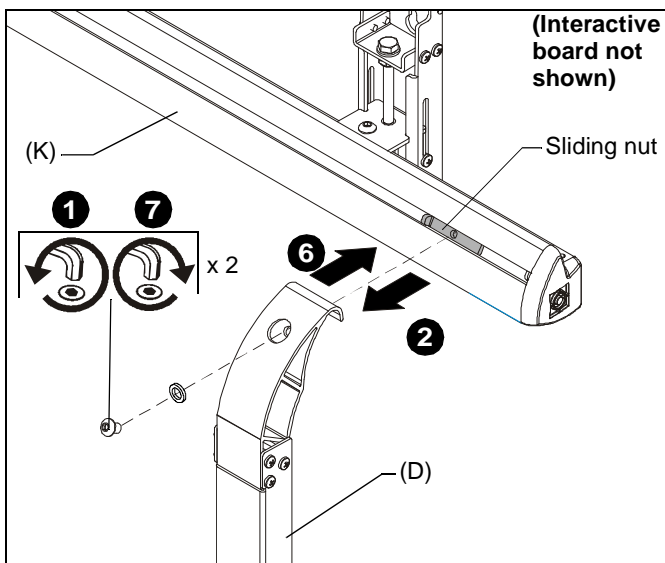

Figure 7

3. Loosen four Phillips head screws on back of white board. (See Figure 8)
4. Adjust white board up or down, as required. (See Figure 8)

5. Tighten four Phillips head screws (H) into four isolation washers (G) and spacers (J) to fasten white board to upright assembly (D). (See Figure 8)

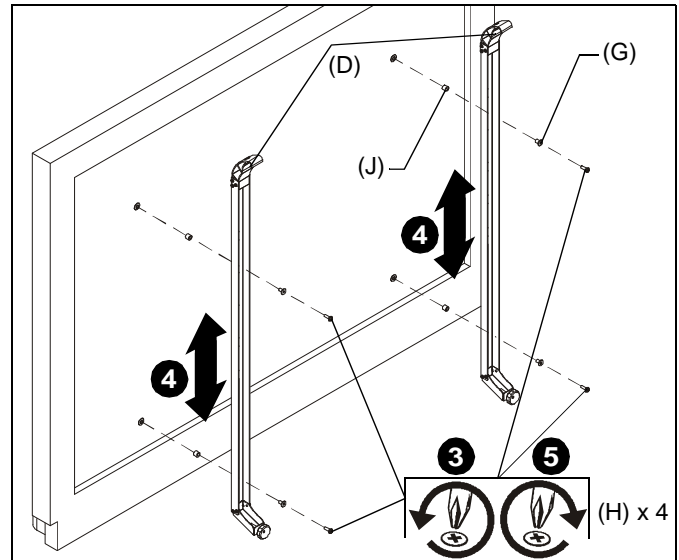

Figure 8

6. Hook whiteboard with attached uprights onto the wall assembly (K). (See Figure 7)
7. Tighten button head cap screw with spacer (loosened in Step 1) at top of each upright assembly to fasten upright assemblies (D) into place. (See Figure 7)

Micro Height Adjust and Leveling

1. The wall assembly (K) can be adjusted or leveled by turning the hex head bolt in the brackets. (See Figure 9)
 - Turn **clockwise** to raise wall assembly
 - Turn **counterclockwise** to lower wall assembly.

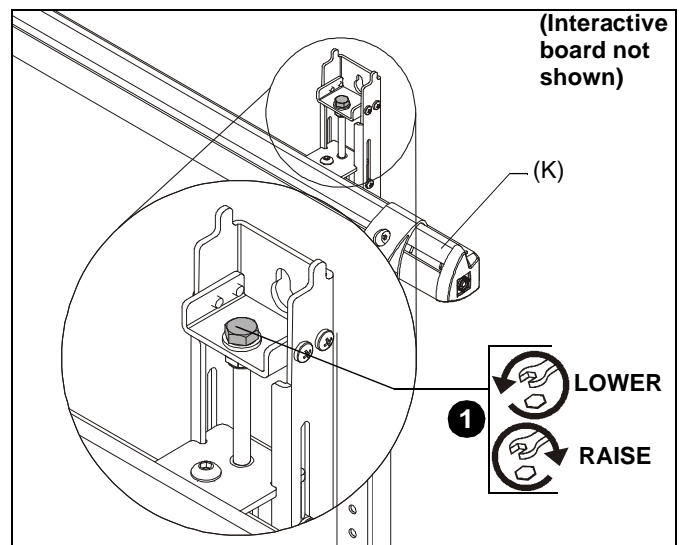

Figure 9

Adding Covers

1. Open the lower flaps of the wall bracket cover (L) outward. (See Figure 10)
2. Slide the cover downward, hooking the top of the wall bracket covers (L) onto the tabs on top of wall assembly brackets. (See Figure 10)
3. Slide the lower flaps of the wall bracket cover (L) under the bottom of the wall assembly brackets (K). (See Figure 10)

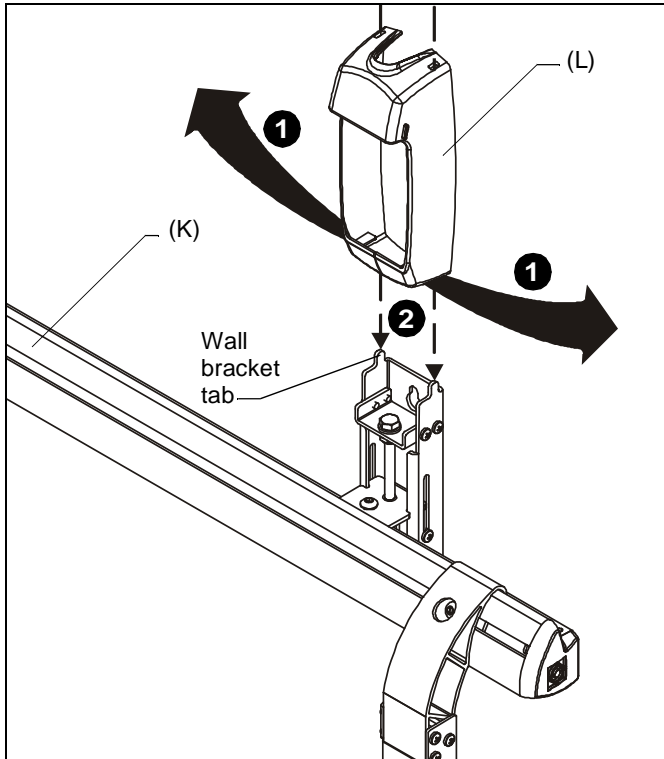

Figure 10

4. Slide the sliding cover (M) down over the wall bracket cover (L). (See Figure 11)

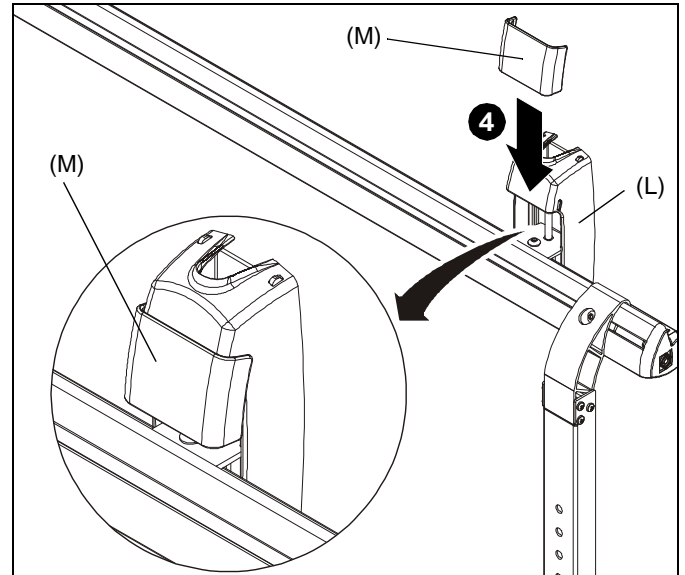

Figure 11



Our Mounts. **Your Vision.**

Chief Manufacturing, a products division
of Milestone AV Technologies

8800-002101 Rev08
©2012 Milestone AV Technologies, a
Duchossois Group Company
www.chiefmfg.com
12/12

USA/International	A 6436 City West Parkway, Eden Prairie, MN 55344 P 800.582.6480 / 952.225.6000 F 877.894.6918 / 952.894.6918
Europe	A Franklinstraat 14, 6003 DK Weert, Netherlands P +31 (0) 495 580 852 F +31 (0) 495 580 845
Asia Pacific	A Office No. 1 on 12/F, Shatin Galleria 18-24 Shan Mei Street Fotan, Shatin, Hong Kong P 852 2145 4099 F 852 2145 4477

