

SONY



HXR-NX3/1

High Quality 3CMOS NXCAM® Handheld Camcorder

A new multi-purpose camcorder offering exceptional image Quality ready to maximize your creative potential as a producer.

The HXR-NX3/1 is a professional camcorder that features Sony's Exmor® 3CMOS Sensors for outstanding image quality. Dual media slots allow simultaneous or relay recording in AVCHD 2.0 (up to 1080 60p) format. There's also a Slow & Quick Motion feature that achieves smooth 2.5x slow motion when recording at 24p, or 60x quick motion recorded at 1 frame per second when recording at 60p. In addition to 20x optical zoom, Clear Image Zoom with Super Resolution Technology provides an extended 40x zoom range with excellent clarity and detail. A built-in LED video light, Wi-Fi®/NFC remote control capability, and a 3.5 inch* LCD panel for enhanced viewing add to the versatility of this multi-purpose camcorder. Battery and charger are supplied.

* Viewable area, measured diagonally.

NXCAM AVCHD



Exmor
3CMOS Sensors



HXR-NX3/1

High Quality 3CMOS NXCAM Handheld Camcorder



Original Sony lens, sensor, and LSI technology for impressive imagery

The HXR-NX3/1 imaging advantage begins with a Sony G™ Lens that offers stunning image quality as well as a wide zoom range. Behind that lens is a 3CMOS Sensor system with three 1/2.8" sensors providing a 2.07 million effective pixel count at the 16:9 aspect ratio. Red, blue, and green lights are independently and accurately captured by separate image sensors, contributing to high resolution, high sensitivity, and wide dynamic range that translate to extraordinarily natural color reproduction. A newly developed LSI that includes advanced noise reduction and several distortion correction technologies handles image processing, allowing clear, low-noise recordings to be captured even in low light. Recorded images are remarkably lifelike in texture and detail.

40x Clear Image Zoom

The high-performance Sony G Lens provided with the HXR-NX3/1 offers an expansive 28.8 mm (35mm full-frame format equivalent) angle of view at the wide end, with a 20x optical zoom range that will easily cover most shooting situations. When more reach is required, Clear Image Zoom employs Super Resolution Technology to provide excellent image quality at between 20x and 40x range.



Wide angle (28.8 mm)



40x Clear Image Zoom (1152 mm)

(Actual images)

AVCHD® 2.0 (1080 60p) and DV recording

HD video is recorded in AVCHD 2.0 (60p) format with a high 60 fps frame rate that achieves smooth, natural subject motion. 60i, 30p, and 24p modes provide playback compatibility with Blu-ray® players. The ability to record in DV format is also provided for users who prefer a DV workflow, and who need to work in a DV compatible non-linear editing environment.



Slow & Quick Motion

Smooth slow or quick motion with full HD quality is available without any extra processing. 2.5x slow motion can be easily achieved by setting the recording format to 24p and the frame rate to 60 fps. If you'd rather speed up the action the frame rate can be set to 1 fps for 60x quick motion when recording at 60p.

Dual media slots, "Simul" or "Relay" recording, and independent rec control

Two media slots allow either simultaneous recording to two memory cards in the "Simul" mode, or "Relay" recording in which recording automatically switches to the second memory card when the first is full. The user can set up the two Start/Stop buttons on the HXR-NX3/1, one on the grip and one on the camcorder body, to independently start and stop recording on different memory cards while recording in "Simul" mode.



Built-in LED video light*

A built-in LED video light is provided just above the camcorder's built-in microphone, providing convenient, bright illumination for a wide range of shooting situations and minimizing the need to carry external lighting equipment. Illumination is approximately 200 lux/1m (approx. 800 lux/0.5m) with a beam angle of 30° and a color temperature of approximately 5500K.

* An external microphone connected via the XLR connector may cast a shadow if used simultaneously with the built-in LED light.



Wi-Fi file transfer and remote control*¹

Low-bitrate MP4 files (720p, 3 Mbps) recorded simultaneously with AVCHD files can be wirelessly transferred to a smartphone or tablet computer and then uploaded directly to cloud servers or social networking sites for preview by editing staff or public viewing.*² One-touch authentication is also possible with smartphones that offer NFC*³ connectivity. Remote control features include monitoring of camera material on the smartphone display, record start/stop, zoom, iris, and touch AF. The required PlayMemories® Mobile*⁴ smartphone application can be downloaded from the Google Play Store or App Store*⁵.

*¹ Wi-Fi operation cannot be guaranteed with all smartphones and tablet computers.

*² MP4 recording is not available when AVCHD (1080 60p) is selected. Only MP4 files can be transferred wirelessly. Timecode is not included in MP4 files. Uploading to web servers/sites must be done via separate applications installed on the smartphone or tablet computer.

*³ NFC, or Near Field Communication, allows close-range wireless communication between the HXR-NX3/1 and an NFC equipped smartphone or tablet computer.

*⁴ PlayMemories Mobile is a free Sony mobile application that allows Wi-Fi communication with Handycam camcorders and other imaging devices.

*⁵ iOS 4.3 through 7.0 or Android 2.3 through 4.3 currently supported.



Timecode and HDMI embedded timecode output

Timecode and user bit settings are important features for professional applications. Timecode is essential for efficient non-linear editing of live footage from multiple NXCAM® camcorders. Like other Sony NXCAM camcorders, HXR-NX3/1 timecode can be reset from the supplied infrared remote control unit, and this allows multiple cameras to be reset simultaneously for easy synchronization. For extra sync versatility, timecode and user bits can also be output via the camcorder's HDMI jack.

Scene Selection

Scene Selection provides professional users with seven presets optimized for a variety of shooting situations. There's the Sunrise & Sunset preset, for example, that instantly optimizes the camcorder settings for brilliant reproduction of sunset or sunrise colors. Or the Spotlight preset that makes it easy to capture subjects lit by spotlights and stage lighting without blown highlights. Scene selection is just one more way that the HXR-NX3/1 offers extra shooting convenience.

Intelligent Auto (iAUTO)

The iAUTO feature makes it easy to capture beautiful images in a wide variety of shooting situations. This handy feature automatically selects the optimum scene setting from three groups of ten scenes. For example, iAUTO can detect that the user is walking while shooting, for example, and automatically select the "Walk" setting from the group that includes the "Walk" and "Tripod" settings to ensure that optimum image quality is achieved.

SCENE group



FACE group



Camera-shake group

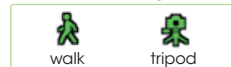

Specifications

HXR-NX3/1 (NTSC)	
General	
Weight	Approx. 4 lb 14 oz, 2.21 kg (with lens hood) Approx. 5lb, 10oz, Approx. 2.54 kg (with lens hood, eyecup, NP-F970 battery)
Dimensions (W x H x D)	Approx. 6.7/8 x 7.5/8 x 15.1/2 inches, 174.5 x 193 x 393 mm (with lens hood, eye piece, and protrusion)
Power Requirements	7.2V (battery pack); 8.4V (AC Adaptor)
Power Consumption	Approx. 6.4W (with XLR mic while recording, EVF On, Video light Off.) Approx. 6.9W (with XLR mic while recording, LCD monitor On, Video light Off)
Operating Temperature	32°F to 104°F (0°C to 40°C)
Storage Temperature	-4°F to +140°F (-20°C to +60°C)
Battery Operating Time (Continuous Recording Time)	Approx. 410 min with NP-F970 battery (video light Off) Approx. 265 min with NP-F970 battery (video light On)
Recording Format (Video)	HD MPEG-4 AVC/H.264 AVCHD 2.0 format compatible
	SD DV(AVI)
	MP4 MPEG-4 AVC/H.264 with MP4 wrapping
Recording Format (Audio)	HD Linear PCM 2ch, 16 bit, 48 kHz/Dolby Digital 2ch, 16 bit, 48 kHz
	SD Linear PCM 2ch, 16 bit, 48 kHz
	MP4 AAC 2ch, 16 bit, 48 kHz
Recording Frame Rate	HD PS (28Mbps) 1920 x 1080/60P, 16:9
	FX (24Mbps) 1920 x 1080/60i, 30p, 24p, 16:9, 1280 x 720/60p, 16:9
	FH (17Mbps) 1920 x 1080/60i, 30p, 24p, 16:9, 1280 x 720/60p, 16:9
	HQ (9Mbps) 1440 x 1080/60i, 16:9, 1280 x 720/60p, 16:9
	LP (5Mbps) 1440 x 1080/60i, 16:9
SD	DV (25Mbps) 720 x 480/60i, 16:9, 4:3
	MP4 (3.5Mbps) 1280 x 720/30p, 24p, 16:9
Recording/Playback Time	Approx. 290 min (SD 64 GB, PS, LPCM)
	Approx. 340 min (SD 64 GB, FX, LPCM)
	Approx. 450 min (SD 64 GB, FH, LPCM)
Lens	
Lens Mount	Fixed
Zoom Ratio	20x (optical), servo/manual
Focal Length	f=4.1 - 82.0 mm equivalent to f=28.8 - 576 mm on 35 mm lens (16:9) equivalent to f=35.2 - 705 mm on 35 mm lens (4:3)
Iris	F1.6 - F11 auto/manual selectable
Focus	AF/MF selectable, 10 mm to ∞ (Wide), 800 mm to ∞ (Tele)
Image Stabilizer	ON/OFF selectable, shift lens
Filter Diameter	M72 mm
Camera Section	
Imaging Device (Type)	3-chips 1/2.8 type Exmor CMOS Sensor
Imaging Device (Pixel Count)	2.41M (total), 2.07M (effective)
Built-in Optical Filters	OFF: Clear, 1: 1/4ND, 2: 1/16ND, 3: 1/64ND
Minimum Illumination	60i: 1.2lux (1/30 Shutter Speed, iris/gain Auto) 60i: 0.4lux (1/30 Shutter Speed, iris Auto, gain 30dB)
Shutter Speed	1/4 sec to 1/10,000 sec
Slow & Quick Motion Function	1080p: Frame rate selectable 1, 2, 4, 8, 15, 30, 60 fps
White Balance	Preset (Outdoor:5600K), A, B
Gain	-6, -3, 0, 3, 6, 9, 12, 15, 18, 21, 24, 27, 30 dB, AGC
Gamma Curve	Selectable
Input/Output	
Audio Input	XLR-type 3-pin (female) (x2), line/mic/mic +48 V selectable
Composite Output	BNC (x1), NTSC
Audio Output	RCA pin
USB	mini-AB USB2.0 Hi-speed/mass-storage/Host
Headphone Output	Stereo mini jack ø3.5mm (x1)
Speaker Output	Monaural
DC Input	DC jack
Remote	Stereo mini mini jack ø2.5mm (x1)
HDMI Output	Type A (x1)

HXR-NX3/1 (NTSC)	
Monitoring	
Viewfinder	0.45 type color LCD: 852 X 3 [RGB] X 480 equivalent, 16:9
Built-in LCD Monitor	3.5-inch* type color LCD monitor: approx. 921000 effective pixels, 640 (H) x 3 (RGB) x 480 (V), 16:9
Built-in Microphone	
Built-in Microphone	Omni-directional stereo electret condenser microphone.
Media	
Type	Memory Stick Duo™ and SD/SDHC/SDXC compatible x1
Built-in LED Light	
Luminous intensity	1.0m / Approx. 200 lx 0.5m / Approx. 800lx
Lighting angle	Approx. 30°
Color temperature	Approx. 5,500K
Wi-Fi	
Supported format	IEEE 802.11 b/g/n
Frequency band	2.4 GHz bandwidth
Security	WEP/WPA-PSK/WPA2-PSK
NFC	NFC Forum Type 3 Tag compliant
Supplied Accessories	
Lens hood (1), Pre-installed to the Camcorder	
EVF eyecup (1)	
Infrared Remote Commander® Control (1)	
Lithium battery (CR2025 for the IR Remote Commander) (1)	
CD-ROM	
Operating instructions in PDF (1)	
Operating instructions (1)	
AC Cable (1)	
COLD SHOE KIT(1)	
warranty (1)	
NP-F770 InfoLithium L Series Rechargeable Battery Package (1)	
AC-VL1 InfoLithium L Series Battery Charger (1)	
DK-415 Power Adapter	

* Viewable area, measured diagonally.
** Shotgun microphone is not supplied.

Dimensions

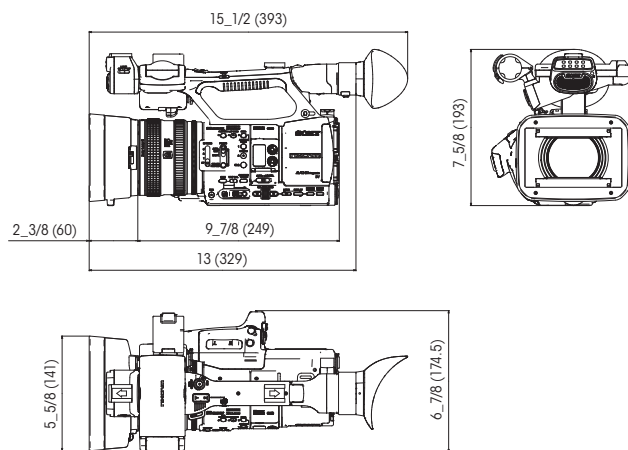

Unit: inches (mm)

Available Accessories

VCL-HG0872K Wide Conversion Lens	2NP-F970/B Rechargeable Battery Pack	ACC-L1BP AC Adaptor/Charger/Battery Kit	VCT-SP2BP Camcorder Support	VCT-PG11RMB Tripod with RM-1BP Remote Controller	RM-1BP Remote Commander Unit	MS-HX32B (32 GB, 16 GB, 8 GB) Memory Stick PRO-HG Duo™
SF-32UX (32 GB, 16 GB, 8 GB) SD/SDHC Memory Card	MS-PX64 (64 GB, 32 GB, 16 GB) Memory Stick PRO-HG Duo™ Mirroring Memory Stick	UWP-D11 Wireless Microphone Package	ECM-VG1 Electret Condenser Microphone	ECM-MS2 Electret Condenser Microphone	ECM-673 Electret Condenser Microphone	