

Digital Video Switcher

SE-2800

(8 / 12 CHANNEL)



Instruction Manual

www.datavideo-tek.com

Contents

Warnings and Precautions	5
Warranty	6
Disposal.....	6
Packing List.....	6
Product Overview	7
Features	7
Connections & Controls	8
Control Panel Overview	8
Main Unit - Rear Panel.....	8
Rear Panel Connections	9
Main Unit – Front Panel	10
HDMI Multi-view	11
How to change the Multi-view output	11
Keyboard Controls – Video Switching	12
Program and Preset rows	12
BG	12
SPEED	12
AUTO TAKE	12
CUT	12
FTB.....	12
T-Bar	12
Keyboard Controls – Video Transitions	13
Transition Selection.....	13
INV	13
FIX / A+V.....	13
MIX.....	13
FREEZE	13
Transition Confirmation	13
Keyboard Controls – LOGO 1, LOGO 2, CLOCK and TIMER	14
LOGO 1	14
LOGO 2 or CLOCK	14
TIMER	14
Keyboard Controls – PIP1, PIP2, DSK1 and DSK2	15
PIP Preset and PIP Program	15
Assigning a video source input to a PIP	15
DSK Preset and DSK Program	15
Assigning an input to a DSK channel for keying.....	15
Keyboard Controls – Frame Store, AUX and Audio level	16
FS – Frame Store Button	16
How to choose live video input or Frame Store	16
AUX Source Selection.....	16
Audio Level.....	16
Menu Options	17
SE-2800 Video Layers	20

PIP – Picture In Picture function	21
PIP Settings.....	21
PIP Preset and PIP Program	21
Assigning a video source input to a PIP	21
DSK function (CG / LUMA KEY)	22
DSK Settings.....	22
DSK Preset and DSK Program	22
Assigning an input to a DSK channel for keying	22
Example SE-2800 and CG-350 Set Up	23
Switcher configuration using a computer – SEConfig software	24
Switcher tab.....	25
Profiles	25
Settings tab	25
Input settings tab	25
Multi screen window signs (labels) tab	26
Still pictures (FS) tab.....	26
Logos tab.....	26
Dynamic Logo tab	27
Multi screen A tab	27
Multi screen B+D tab.....	27
Multi screen C+E tab.....	27
Controlling the switcher with a computer – SE Remote software	28
Software based Macro functions.....	28
REC & PLAY functions.....	28
TIME function	28
SET function.....	28
AUDIO function	29
Overview	29
Audio Menu Options – De-embedding SDI or HDMI audio	29
Audio Menu Options – Monitoring the audio levels.....	30
Audio Menu Options – Changing the audio input level.....	31
Changing the audio output level.....	31
GPI / GPO Connections	32
SE-2800Tally Outputs	33

How to update the SE-2800 Firmware	34
How to Re-calibrate the SE-2800 T-Bar	38
How to change the SE-2800 video standard	39
Example SE-2800 Set Up	43
Dimensions.....	43
Specification.....	44
Service and Support	45

Disclaimer of Product and Services

The information offered in this instruction manual is intended as a guide only. At all times, Datavideo Technologies will try to give correct, complete and suitable information. However, Datavideo Technologies cannot exclude that some information in this manual, from time to time, may not be correct or may be incomplete. This manual may contain typing errors, omissions or incorrect information. Datavideo Technologies always recommend that you double check the information in this document for accuracy before making any purchase decision or using the product. Datavideo Technologies is not responsible for any omissions or errors, or for any subsequent loss or damage caused by using the information contained within this manual. Further advice on the content of this manual or on the product can be obtained by contacting your local Datavideo Office or dealer.



Warnings and Precautions

1. Read all of these warnings and save them for later reference.
2. Follow all warnings and instructions marked on this unit.
3. Unplug this unit from the wall outlet before cleaning. Do not use liquid or aerosol cleaners. Use a slightly damp cloth for cleaning.
4. Do not use this unit in or near water.
5. Do not place this unit on an unstable surface, cart, stand, or table. The unit may fall, causing serious damage.
6. Any slots and openings on the case top, back, and bottom are provided for ventilation. To ensure safe and reliable operation of this unit, and to protect it from overheating, do not block or cover these openings. Do not place this unit on a bed, sofa, rug, or similar surface, as the ventilation openings may become blocked. This unit should never be placed near or over a heat source or radiator. This unit should not be placed in a built-in installation unless proper ventilation is provided.
7. This product should only be operated from the type of power source indicated on the marking label of the AC adapter. If you are not sure of the type of power available, consult your Datavideo dealer or your local power company.
8. Do not allow anything to rest on the power cord. Do not locate this unit where the power cord will be walked on, rolled over, damaged or otherwise stressed.
9. If an extension cord must be used with this unit, make sure that the total of the ampere ratings on the products plugged into the extension cord do not exceed the extension cord rating.
10. Make sure that the total amperes of all the units that are plugged into a single wall outlet do not exceed 15 amperes.
11. Never push objects of any kind into this unit through the case ventilation slots, as they may touch dangerous voltage points or short out parts that could result in risk of fire or electric shock. Never spill liquid of any kind onto or into this unit.
12. Except as specifically explained elsewhere in this manual, do not attempt to service this product yourself. Opening or removing covers that are marked "Do Not Remove" may expose you to dangerous voltage points or other risks, and will void your warranty. Refer all service issues to qualified service personnel.
13. Unplug this product from the wall outlet and refer to qualified service personnel under the following conditions:
 - a. When the power cord is damaged or frayed;
 - b. When liquid has spilled into the unit;
 - c. When the product has been exposed to rain or water;
 - d. When the product does not operate normally under normal operating conditions. Adjust only those controls that are covered by the operating instructions in this manual; improper adjustment of other controls may result in damage to the unit and may often require extensive work by a qualified technician to restore the unit to normal operation;
 - e. When the product has been dropped or the case has been damaged;
 - f. When the product exhibits a distinct change in performance, indicating a need for service.

Warranty

Standard Warranty

- Datavideo equipment is guaranteed against any manufacturing defects for one year from the date of purchase.
- The original purchase invoice or other documentary evidence should be supplied at the time of any request for repair under warranty.
- Damage caused by accident, misuse, unauthorized repairs, sand, grit or water is not covered by this warranty.
- All mail or transportation costs including insurance are at the expense of the owner.
- All other claims of any nature are not covered.
- Cables & batteries are not covered under warranty.
- Warranty only valid within the country or region of purchase.
- Your statutory rights are not affected.

Two Year Warranty

- All Datavideo products purchased after 01-Oct.-2008 qualify for a free one year extension to the standard Warranty, providing the product is registered with Datavideo within 30 days of purchase. For information on how to register please visit www.datavideo-tek.com or contact your local Datavideo office or authorized Distributors.
- Certain parts with limited lifetime expectancy such as LCD Panels, DVD Drives, Hard Drives are only covered for the first 10,000 hours, or 1 year (whichever comes first).

Any second year warranty claims must be made to your local Datavideo office or one of its authorized Distributors before the extended warranty expires.



Disposal



For EU Customers only - WEEE Marking

This symbol on the product indicates that it should not be treated as household waste. It must be handed over to the applicable take-back scheme for the recycling of Waste Electrical and Electronic Equipment. For more detailed information about the recycling of this product, please contact your local Datavideo office.

Packing List

Item	Description	Quantity
1	SE-2800 Main Unit	1
2	SE-2800 Keyboard/Control Panel	1
3	Switching Adaptor DC 12V / 5A XLR	1
4	AC power cord	1
5	DB 9P(F) to DB 9P(F) Cable Length:1.5m	1
6	PVC Mylar (Wipe Function )	1
7	PVC Mylar (Wipe Function )	1
8	SE-2800 Instruction Manual	1

Product Overview

The SE-2800 is a cost effective HD/SD switcher featuring 8* or 12 channels. Thanks to a 2RU 19" form factor and 12V DC input the SE-2800 is ideal for use in portable rack units or outside broadcast vehicles. The SE-2800 produces superb 10 bit 4:2:2 broadcast quality pictures while also offering flexible input and output configurations. The SE-2800 also has powerful, easy to use effects, such as dual picture in picture (PIP), downstream keyers (DSK) and logo insertion, as well as a clock and multiple still image frame stores.

The SE-2800 has been designed for live productions such as concerts, conference, sports and worship events as well as news and studio based programmes that may need to combine a number of video sources with a mixed audio feed. The unit can also be configured and controlled over an Ethernet network allowing even greater flexibility and even more user set up options.

That's Datavideo, sharing the value!

**Eight channel units can be upgraded to twelve at a later date – Please speak with your dealer for more information.*

Features

- A flexible variety of input choices. The twelve input version can be configured as:
 - Twelve SDI or HD-SDI inputs,
 - Or Nine SDI or HD-SDI inputs with three HDMI inputs,
 - Or Six composite inputs, with three SDI inputs and three HDMI inputs
 - Or Six composite inputs, with six SDI inputs.
- The eight input version* can be configured as:
 - Eight SDI or HD-SDI inputs,
 - Or Six SDI or HD-SDI inputs with two HDMI inputs,
 - Or Four composite inputs, with two SDI inputs and two HDMI inputs
 - Or Four composite inputs, with four SDI inputs.
- HDMI based single or dual screen multi-view outputs.
 - A choice from five set ups, two with optional HDMI Program output.
- Three user defined SDI or HD-SDI outputs.
 - Each of these outputs has the option to be:
 - Program output
 - Or Preview output
 - Or Program output without logo
 - Or Program output without logo and DSK overlay
 - Or Aux output of a selected video input channel (single Aux).
- User defined and positioned dual picture in picture (PIP).
- Easy two step PIP source assignment using keyboard.
- Two downstream keyers (DSK) with a set up choice of basic Luma key or alpha channel.
- Easy two step DSK source assignment using keyboard.
- User choice from seven stored logos for insertion on preview and program outputs.
- One dynamic logo or moving image sequence. File type can be TGA, GIF or AVI up to 75 frames long.
- Frame Store (FS) source for each input channel. User can quickly toggle between a pre-loaded still image and the connected live source.
- On screen real-time clock featuring HH:MM only – User defined position.
- User defined countdown timer for each input shown within the HDMI Multi-view output.
- Six user defined wipe buttons - choice of 16 wipes with optional border.
- User can define three speed buttons (in frames) for selected transition when using Auto Take button.
- T-Bar can be operated in one way or two way mode.
- Choice of 8 full raster colour backgrounds or SMPTE 75% bars for BG button.
- Up to four channels of audio can be embedded on to the SDI and HDMI Program outputs. Either from an external audio mixer (not supplied) or selected HDMI, SDI and analogue XLR inputs.
- Audio peak meters displayed on HDMI Multi-view gives confidence of incoming and outgoing audio.
- User choice for synch input and loop through – composite black & burst or HD Tri-Level sync.
- SE-2800 can be configured over an Ethernet network using a supplied Windows 7 PC application.
- SE-2800 can be controlled remotely over an Ethernet network using a supplied Windows 7 PC application.
- Low voltage Bi-colour Tally output on a single 25pin D-sub connector – compatible with other Datavideo equipment or bespoke applications.
- GPI - Externally trigger transitions or devices using the 3.5mm jack socket.
- XLR 12V DC input – Makes the unit ideal for studio or OB van based applications.

Connections & Controls

Control Panel Overview

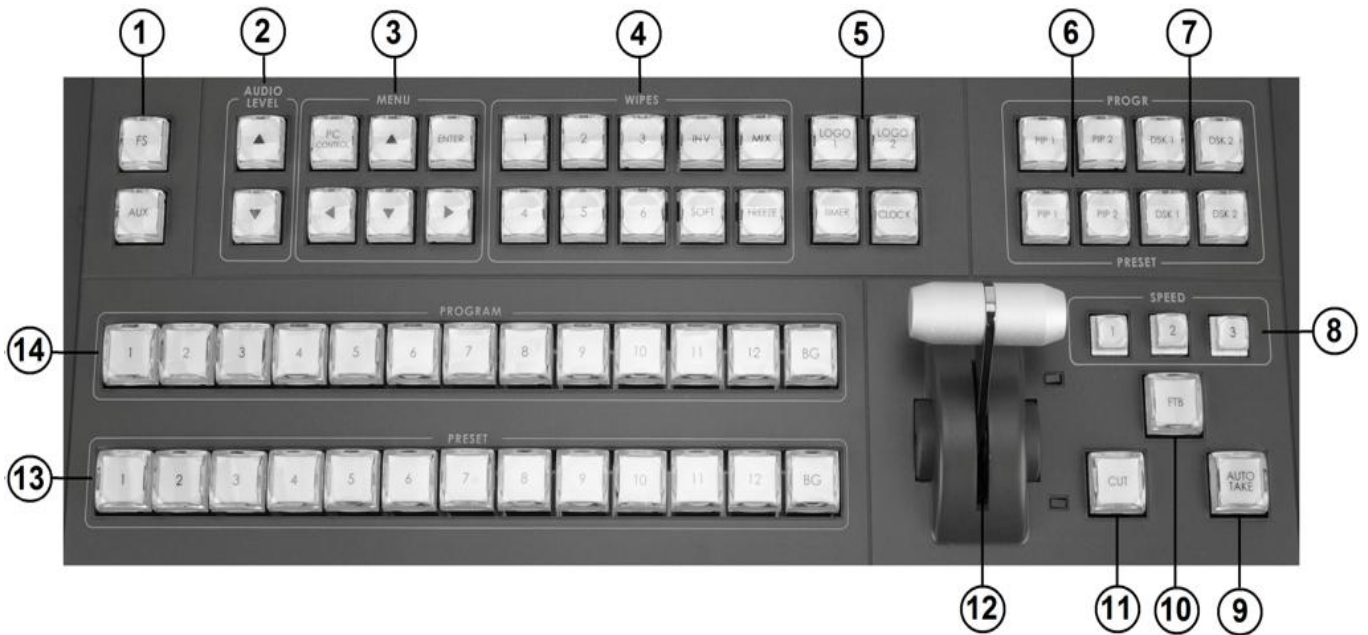

- | | |
|-------------------------------|--------------------------------|
| 1. Frame Store button | 8. Speed Selection |
| 2. Audio Level buttons | 9. AUTO TAKE |
| 3. PC / Menu control | 10. FTB – Fade To Black |
| 4. Transition selection | 11. CUT |
| 5. Logos 1 & 2, Clock & Timer | 12. T-Bar – Manual Transitions |
| 6. PIP selection PST & PGM | 13. Preset Row (PST) |
| 7. DSK selection PST & PGM | 14. Program Row (PGM) |

Main Unit - Rear Panel

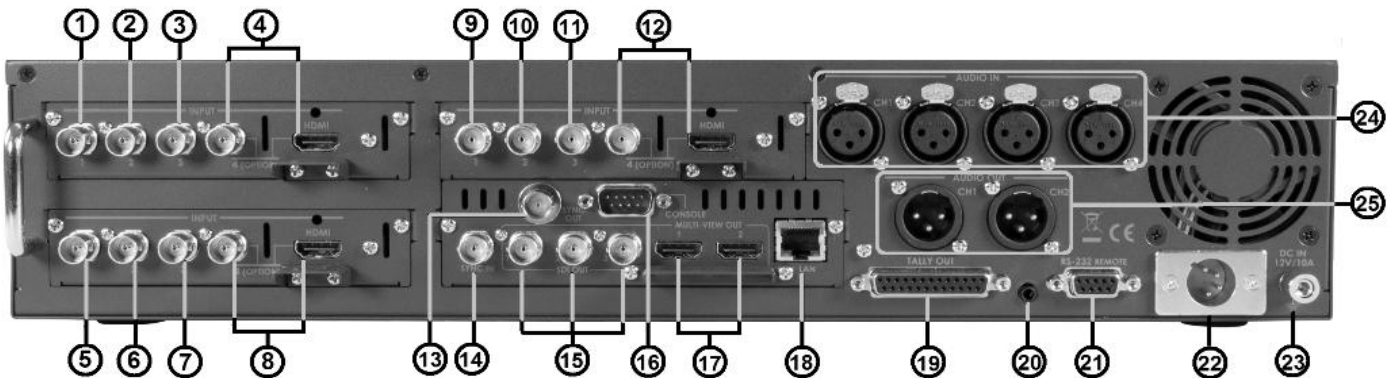

- | | |
|--------------------------------------|--|
| 1. Input 1 – SD / HD-SDI / CVBS | 13. Sync Output |
| 2. Input 2 – SD / HD-SDI / CVBS | 14. External Sync Input |
| 3. Input 3 – SD / HD-SDI | 15. User Defined Outputs 1~3 |
| 4. Input 4 – SD / HD-SDI / HDMI | 16. Connect the SE-2800 keyboard here |
| 5. Input 5 – SD / HD-SDI / CVBS | 17. User Defined Multi Image Outputs |
| 6. Input 6 – SD / HD-SDI / CVBS | 18. Ethernet port for PC control & updates |
| 7. Input 7 – SD / HD-SDI | 19. Tally Output connector |
| 8. Input 8 – SD / HD-SDI / HDMI | 20. GPI connector |
| ** 9. Input 9 – SD / HD-SDI / CVBS | 21. RS-232 connector (not currently used) |
| ** 10. Input 10 – SD / HD-SDI / CVBS | 22. 4pin XLR Power Input connector |
| ** 11. Input 11 – SD / HD-SDI | 23. Grounding Terminal |
| ** 12. Input 12 – SD / HD-SDI / HDMI | 24. 3pin XLR Audio Inputs |
| | 25. 3pin XLR Audio Outputs |

** Please note inputs 9 to 12 are not present if you have purchased the eight channel SE-2800. Eight channel units can be upgraded to twelve inputs, please talk with your local dealer.

Rear Panel Connections

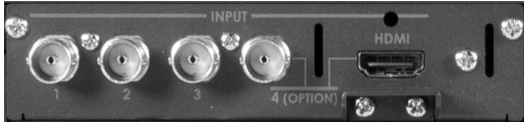

1920x1080 HD Inputs	HD-SDI BNC	HDMI
1, 5 & 9	Yes	---
2, 6 & 10	Yes	---
3, 7 & 11	Yes	---
4, 8 & 12	Yes	Yes

SD Inputs	CVBS BNC	SDI BNC	HDMI
1, 5 & 9	Yes	Yes	---
2, 6 & 10	Yes	Yes	---
3, 7 & 11	---	Yes	---
4, 8 & 12	---	Yes	Yes

Video Input Modules

The SE-2800 can be supplied with eight or twelve video input channels.

An SE-2800 with eight input channels has two video input modules fitted. An SE-2800 with twelve input channels has three video input modules fitted. An eight channel unit can be upgraded to twelve inputs by adding another Video Input Module.

There are four video input channels on each Video Input Module. Each Video Input Module (shown top left) has the same connections, four BNC connectors and one HDMI port. The fourth BNC connector and the HDMI port are an option for the same input channel.

The two tables, on the left, show which types of video inputs can be connected to the SE-2800 switcher. For example, only input channels 4, 8 and 12 have the HDMI input option.

NOTE: The switcher cannot accept 1280x720 or 1440x1080 inputs and has no input scaling options.

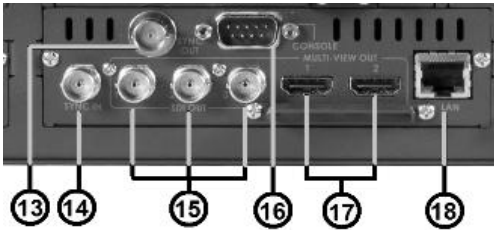

SYNC I/O

The SE-2800 can be synchronised with other studio equipment such as cameras and House sync. Input BNC (14) will accept House sync or Tri-level sync. Output BNC (13) can be used to pass the sync signal to other studio equipment such as cameras or recorders.

CONSOLE

This 9pin D-Sub connector (16) is used to connect the Control Panel / Keyboard to the rear of the SE-2800 Main Processing unit.

HDMI MULTIVIEW OUT

The SE-2800 has two HDMI outputs (17) which can be used to display a preset combination of inputs plus program and preset. See page 11 for the five preset multi-view options.

SDI VIDEO OUTPUTS

The three BNC output connectors (15) are user defined SDI outputs. Each of these SDI outputs has the option to be:

1. Program output
2. Preview output
3. Program output without logo
4. Program output without logo and DSK subtitles
5. Aux output of a selected video input channel

SDI outputs 2 and 3 also have the option to be a Program output which has been downscaled from HD to SD resolution.

ETHERNET PORT

This RJ45 Ethernet port (18) is used to connect the SE-2800 to a PC for remote control, or to update the unit's firmware, or to configure the switcher. See **page 24** for more details.

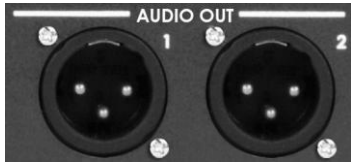

AUDIO OUT

Supports two channels XLR Balanced Audio output.

See **page 29** for more details.



AUDIO IN

Supports four channels XLR Balanced Audio Input.

See **page 29** for more details.



TALLY OUT

The SE-2800 Tally Output port provides bi-colour tally information to a number of other Datavideo products, such as the ITC-100 eight channel talkback system or the Datavideo TLM range of monitors. See **page 33** for more details.

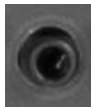

GPI

The GPI socket can be used for simple external control. See **page 32** for more details.



RS-232 REMOTE

This feature is not currently active. A firmware update may be released at a later date. Please check with your local Datavideo office for advice on this connection and the latest firmware.

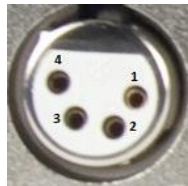
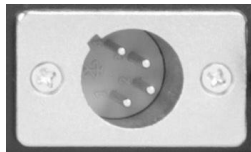

DC IN

Connect the supplied 12V 5A PSU to this 4pin XLR socket.

- Pin 1 = GND (-)
- Pin 2 = NC
- Pin 3 = NC
- Pin 4 = VCC (+)



Grounding Terminal

When connecting this unit to any other component, make sure that it is properly grounded by connecting this terminal to an appropriate point. When connecting, use the socket and be sure to use wire with a cross-sectional area of at least 1.0 mm.

Main Unit – Front Panel



The front panel on the SE-2800 main unit has a grille for two airflow cooling fans. Please do not block or cover this grille as the unit may overheat. This grille should also be kept free of dust. The front panel can be removed by using the four thumbscrews. A soft brush or cloth can then be used to clean the grille before attaching it back to the unit.

The power button starts and shuts down both the SE-2800 main unit and its attached keyboard.

HDMI Multi-view

SE-2800 Multi-view monitoring is available across one or two HDMI monitors (not supplied). These outputs can be used to monitor video and audio in a number of different configurations. For each set up, embedded audio level indication is available on all inputs and the Program window.

This Multi-view is supplied from the HDMI connection(s) on the rear panel. (See page 8, Rear Panel, item 17.) When connected to two compatible HDMI monitors a variety of multi-image layouts is possible.

Configuration A:

- On HDMI screen 1: 9 live inputs
- On HDMI screen 2: 3 live inputs with additional Preview and Program windows

Configuration B:

- On HDMI screen 1: 12 live inputs with additional Preview and Program windows
- On HDMI screen 2: Program window

Configuration C:

- On HDMI screen 1: 8 live inputs with additional Preview and Program windows
- On HDMI screen 2: Program window

Configuration D:

- On HDMI screen 1: 12 live inputs with additional Preview and Program windows
- On HDMI screen 2: Same as HDMI screen 1

Configuration E:

- On HDMI screen 1: 8 live inputs with additional Preview and Program windows
- On HDMI screen 2: Same as HDMI screen 1

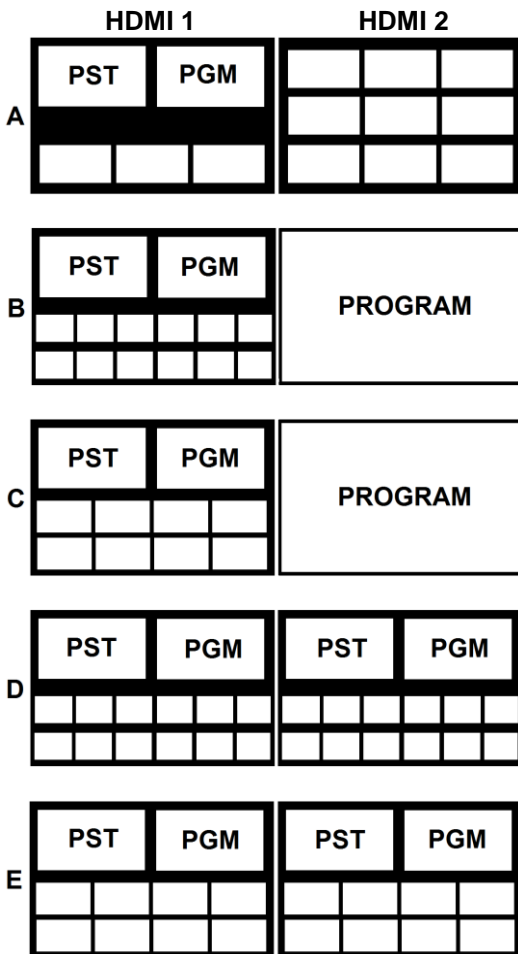

Shown left are the five multi-view configuration options A to E.

How to change the Multi-view output

To change the multi-view option on your switcher press the **ENTER** button in the MENU area of the SE-2800 Control Panel / Keyboard. This will display an on screen menu on HDMI output 1. Then use the arrow down button to highlight the option **Multi Screen Mode**. Use the arrow keys to highlight your preferred option from those shown on the left. Use the arrow keys to place a tick in the selection box and then press **ENTER** to save this choice.

On screen Tally indication

The SE-2800 Multi-Image Preview supplies basic tally information by highlighting the live Program input source with a red border, and the cued next input source with a yellow border.

Function Area

Below the Program and Preset image windows is a function area occupied by a real time Clock, Countdown Timer (if active), chosen Wipe indicator, PC or Console control indication and chosen Audio mix and Audio level indicators.

Labels

Below each video input channel window there is a label. These labels can be edited using the software supplied with the SE-2800, see **page 24** for more details.

Keyboard Controls – Video Switching

Program and Preset rows

The Program row of buttons is the active channel, this is the live output. The active channel will appear as the Program Output (PGM). You can switch or CUT from one video source to another directly on the Program row. You will see the multi view PGM output change as you press different keys along this top row of buttons.

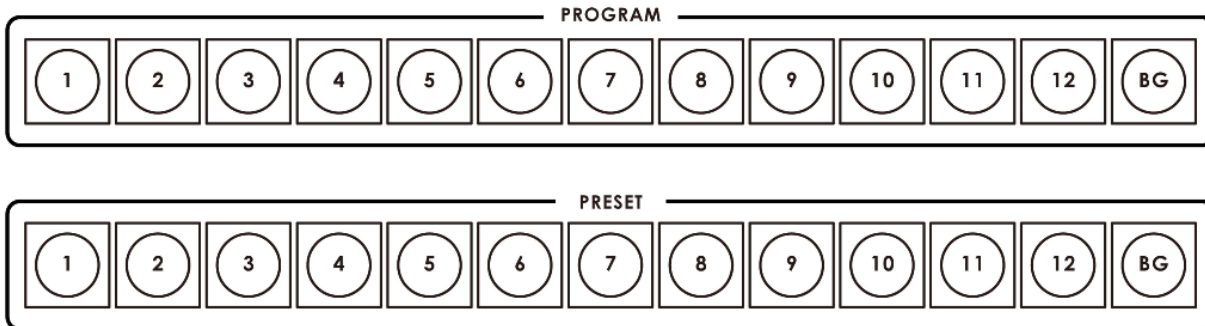

The Preset row is the cued channel, this channel will appear in the PST or Preview window. The Preset row selection decides which input will be transitioned to next when using any of the transition controls.

N.B. The keys on the Program and Preset rows will be inactive while the T-Bar is active or moving. Only when the T-Bar is fully up or fully down will the keys respond.

BG

Background button – assigns a background colour or SMPTE 75% bars for use on the Program and Preset row.

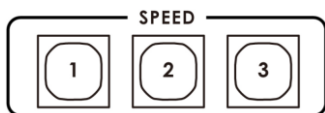

SPEED

There are three speed buttons which can be defined by the user. By pressing a speed button the user is choosing the rate of transition or time taken when using the AUTO TAKE button.



AUTO TAKE

This performs an automated switch from the current program source to the selected preset source. The selected transition wipe or dissolve will also be used. The timing of the transition is set by the chosen Speed button.



CUT

This performs a simple immediate switch from the current main source to the selected sub source. The selected transition wipe or dissolve is not used.



FTB

Fade To Black, this button fades the current video program source to black. When pressed again it acts in reverse from complete black to the currently selected program video source.

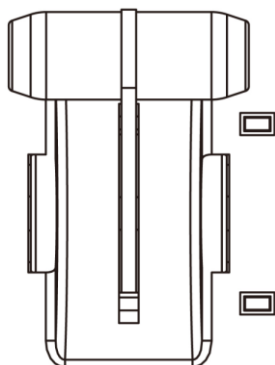

T-Bar

This performs a manually controlled transition from the current program source to the selected preset source. The selected transition wipe or dissolve will be used. When the T-Bar has travelled as far as it can go the transition between sources is complete. The T-Bar has indicators next to it which light when the transition is complete.

The T-Bar can be operated in one of two modes which is chosen by a menu option, see **page 17** onwards for more details.

Keyboard Controls – Video Transitions

Transition Selection

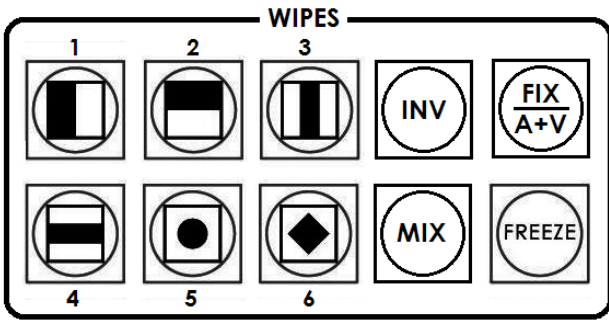

The SE-2800 features six user defined wipe buttons, an A/B dissolve or **MIX** button, an **INV** or Invert wipes button and a **FREEZE** button.

All wipes can have an optional colour border applied. The wipe border width and colour are chosen within the menu system.

Transitions can be performed manually using the T-Bar or automatically by using the **SPEED** and **AUTO TAKE** buttons.

- Vertical Wipe Left to Right.
- Horizontal Wipe Bottom to Top.
- Vertical Wipes from Centre to Left and Right sides.
- Horizontal Wipes from Centre to Top and Bottom.
- Circle Wipe from Centre to outside edges.
- Diamond Wipe from Centre to outside edges.
- Box Wipe from Centre to outside edges.
- Diagonal wipe from upper left to lower right.

- Vertical Wipe Right to Left.
- Horizontal Wipe Top to Bottom.
- Vertical Wipes from Left and Right sides to Centre.
- Horizontal Wipes from Top and Bottom to Centre.
- Circle Wipe from outside edges to Centre.
- Diamond Wipe from outside edges to Centre.
- Box Wipe from outside edges to Centre.
- Diagonal wipe from lower right to upper left.

INV
Invert the selected wipe so it travels in the opposite direction.

MIX
Pressing this button selects a basic **A/B Dissolve** for the next transition.

FIX / A+V
Switch the audio mixing selection between **Audio Fixed** and **Audio-F-Video (A+V)**.

FREEZE
Freeze the program source image or return to live video of the selected program source.

Transition Confirmation

The selected transition is highlighted in the status area of the HDMI multi-view output. When the **INV** button is pressed the six wipe icons change to their opposite direction icon.



Keyboard Controls – LOGO 1, LOGO 2, CLOCK and TIMER

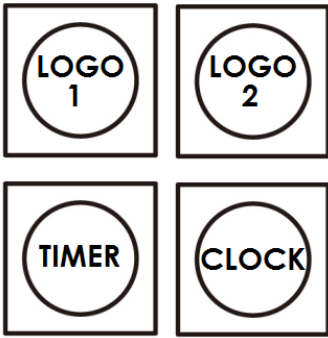

The SE-2800 has the ability to store six static logos and one dynamic logo. The logo files are transferred to the SE-2800 from a Windows PC using the Ethernet connection and the supplied **SEConfig software**. See **page 24** for more details on using this software.

LOGO 1

The LOGO 1 and LOGO 2 buttons are used to display pre-selected logos on the SE-2800 Preset and Program outputs. When the button is active the selected logo is shown. These logos are selected from the switcher's memory and positioned using a menu option see **page 17** for details.

LOGO 2 or CLOCK

The user cannot display LOGO 2 and CLOCK at the same time. Instead use LOGO 1 and CLOCK together or use LOGO 1 and LOGO 2 together.

The clock time can be synchronised with a computer or set manually using a menu option. The colour and font used in the clock digits can be changed using the supplied **SEConfig software**. See **page 24** for more details on using this software or see **page 17** onwards for the Clock menu options.

TIMER

In some mixing or switching applications it is useful to have a countdown timer. It could be that the input is a pre-recorded video clip and you need to know when to be ready to switch away from it.

This countdown timer function is only seen in the status area of the HDMI multi-view output to the right of the normal Clock function. The timer can be selected for one input channel, several channels or all channels.

When the TIMER button is active and the user switches to a selected input channel the countdown starts on the HDMI multi-view.

The value of the countdown, in minutes and seconds (MM:SS), is set by a menu option. Whilst the countdown is in progress T-Bar operation is ignored.

When the countdown reaches zero the user can then switch or transition to another input channel. If the countdown reaches zero the switcher will not automatically change to the selected Preset source.

Keyboard Controls – PIP1, PIP2, DSK1 and DSK2

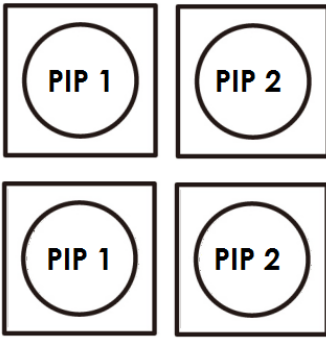

PIP Preset and PIP Program

When looking at the top right corner of the SE-2800 Control Panel / Keyboard there are four PIP keys. These are labelled Program and Preset. The upper PIP1 and PIP2 keys relate to activating Picture In Picture images on the Program outputs. The lower PIP1 and PIP2 keys relate to activating Picture In Picture images on the Multi-view or Preview outputs.

Assigning a video source input to a PIP

Using the lower PIP1 or PIP2 buttons you can assign a selected video input to the chosen PIP video layer.

- 1) First press and hold down the required PIP button on the lower row. The Preset row of input sources will light.
- 2) While still holding down the PIP button, press to select the required input from the Preset row.
- 3) The input will flash to confirm it is selected.

This selection will also be confirmed on the HDMI Multi-view, with a P1 or P2 label shown next to the selected input image.

The full PIP process is described on **page 21**.

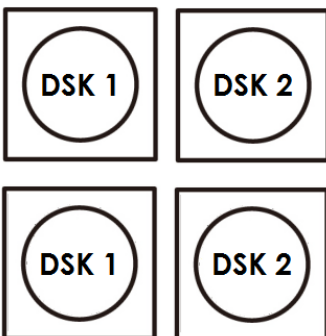

DSK Preset and DSK Program

When looking at the top right corner of the SE-2800 Control Panel / Keyboard there are four DSK keys. These are labelled Program and Preset. The upper DSK1 and DSK2 keys relate to activating Down Stream Keying on the Program outputs. The lower DSK1 and DSK2 keys relate to activating Down Stream Keying on the Multi-view or Preview outputs.

Assigning an input to a DSK channel for keying

Using the lower DSK1 or DSK2 buttons you can assign a selected video input to the chosen DSK video layer.

1. First press and hold down the required DSK button on the lower row. The Preset row of input sources will light.
2. While still holding down the DSK button, press to select the required input from the Preset row.
3. The input will flash to confirm it is selected.

This selection will also be confirmed on the HDMI Multi-view, with a T1 or T2 label shown next to the selected input image.

The full DSK process is described on **page 22**.

Keyboard Controls – Frame Store, AUX and Audio level

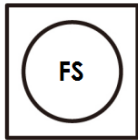

FS – Frame Store Button

The SE-2800 has eight or twelve video channels, depending on the number of inputs it has. Each of these channels has its own Frame Store, making a total of eight or twelve Frame Stores. Each of these Frame Stores can hold one still image. This still image can be called into the production by using the FS button located at the top left corner of the SE-2800 Control Panel / Keyboard. The FS button allows the user to toggle between the still image of the Frame Store or the live video input also connected to that same video channel.

How to choose live video input or Frame Store

1. First press and hold down the FS button. The Preset row of input sources will light.
2. While still holding down the FS button, press the required input on the Preset row.
3. The input button will flash to confirm the Frame Store is selected.

This selection will also be confirmed on the HDMI Multi-view, with the selected channel showing the live input or frame store image.

The contents of each Frame Store is uploaded to the SE-2800 from a PC. The supplied SEConfig software is used to do this. The file upload process is described on **page 24**.

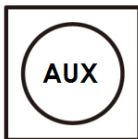

AUX Source Selection

The SE-2800 has three user defined SDI outputs, see page 9 item 15. One or all of these outputs can be set up as an auxiliary (AUX) output via a menu option. See **page 17** onwards for details.

The AUX output source can be quickly selected in the following way.

1. First press and hold down the AUX button. The Preset row of input sources will light.
2. While still holding down the AUX button, press the required input on the Preset row.
3. The input button will flash to confirm the AUX source is selected.

This selection will also be confirmed by the SD/HD-SDI Monitor supplied with these AUX images.

Audio Level

The SE-2800 has ability to do a basic mix/switch of analogue, SDI and HDMI embedded audio, see **page 29** for details.

The AUDIO LEVEL buttons are related to the level of the Program audio output, whether SDI embedded or analogue XLR.

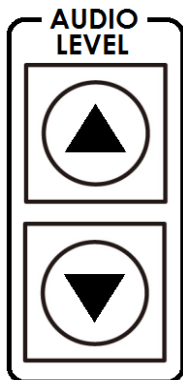

Menu Options

When the **ENTER** button is pressed the Main Menu list is displayed on the HDMI 1 Multi-view output.

This section covers the Menu options in the order that they appear on the SE-2800 HDMI 1 Multi-view. These settings may also appear in more detail elsewhere in this instruction manual. Options may vary depending on the firmware version in use.

Once the chosen setting has been confirmed with the **ENTER** button it is stored within the switchers non-volatile memory.

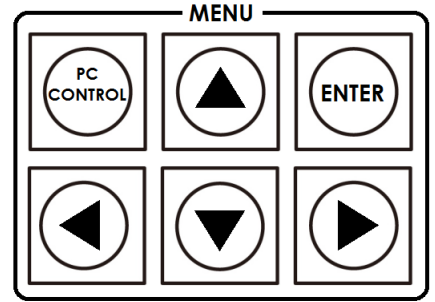

Version Number	v01.66 (NTSC) v02.51 (PAL)		
Input Video Settings	Brightness Contrast Saturation Aperture Y-C Delay Set To Nominal	Range xx to xx Range xx to xx Range xx to xx Not used in current firmware Not used in current firmware Reset to default values	
Inputs Standard and Format	Inputs 1,2,5,6,9 &10 Inputs 3,7 &11 Inputs 4,8 &12	Can be a choice of Can be a choice of Can be a choice of	HD SDI* SD SDI 4:3 SD SDI 16:9 CVBS 4:3 CVBS 16:9 HD SDI* SD SDI 4:3 SD SDI 16:9 or HDMI* HDMI SD 4:3 HDMI SD 16:9 <i>*All HD inputs are natively 16:9 aspect.</i>
Input Audio Settings	Level Nominal	Range -60 to +60 Resets value to zero	
SDI Embedded Audio Set.	Inputs 1 to 12	User choice of	Group 1,2,3 or 4 Pair 1 or 2
HDMI in Embedded Audio Pair	Input 4,8 or 12	User choice of	Group 1,2,3 or 4
Outputs Emb Audio Group	Outputs 1,2 or 3	User choice of	Group 1,2,3 or 4
Auto Audio Mixing Type	User choice of	X type or V type Tick selection	X type = A/B cross fade V type = Fade out A then Fade in B
T-Bar Audio Mixing Type	Tick selection of	Follow auto audio mixing type By the end	

PIP Settings	Position PIP1 Size PIP1 Border PIP1 Position PIP2 Size PIP2 Border PIP2	X-Position (Left to right) = 000 to 097 Y-Position (Lower to Upper) = 000 to 108 PIP Size = 1 (small) to 33 (large) Border Size = 0 (OFF), 1 (Thin) to 15 (Thick) Border Color = 1 to 8 (user defined colours) 1=Yellow, 2=Cyan, 3=Green, 4=Magenta, 5=Red, 6=Blue
LOGO Settings	Logo1 Logo2	X-Position (Left to right) = 000 to 110 Y-Position (Lower to Upper) = 000 to 135 Selection = 1 to 8 Logo selection 1 to 7 are still image Logo 8 selection is dynamic moving image
Speed Buttons Setting	Speed1 Speed2 Speed3	Range 1 to 127 (Frames)
Wipe Buttons Setting	Buttons 1 to 6	Wipe 1 to 8 (See page 13 also) Soft Edge 0 to 4 Color 1 to 8 1=Yellow, 2=Cyan, 3=Green, 4=Magenta, 5=Red, 6=Blue
Outputs Mode	OUT 1 is an HD SDI only user choice of <ul style="list-style-type: none"> Program Program Logo Free Program Logo & Titles Free Preview Aux OUT 2 user choice of Standard & Format <ul style="list-style-type: none"> HD SDI SD SDI 4:3 SD SDI 16:9 Plus MODE choice of <ul style="list-style-type: none"> Program Program Logo Free Program Logo & Titles Free Preview Aux OUT 3 has the same user choices as OUT 2	
DSK Settings	Titles 1 Titles 2	Titles + a-CH mode (alpha channel) Luma Key mode Luma Key Level 0 (black) to 255 (white)
BG Color Setting	User choice of Back Ground colour from 1 to 9 1=White, 2=Yellow, 3=Cyan, 4=Green, 5=Magenta, 6=Red, 7=Blue, 8=Black 9 = SMPTE 75% colour bars	

T-Bar Mode	One Way Mode Two Way Mode	= T-Bar operates transition in only one direction = T-Bar operates transition in both directions
1kHz to Bars	When BG Color Setting option above = 9 1kHz tone can be ON or OFF depending on tick selection	
Keys Brightness	User choice of 1 to 4 Brightness of keyboard buttons, 1= Low, 4= High	
Keys Mode	Tick selection ON or OFF, ON=Active buttons are Red, OFF=Green is Active	
Audio Level is shown	Tick selection ON or OFF, ON=Audio Peak Meters shown on HDMI Multi-view	
Reference	External Mode	Tick selection for ON or OFF Choice of HD Analog 3 Level Signal Or SD Composite PAL/NTSC H-Timing Zero to 15
Aux	The value shown here relates to the selected input – See page 16 also. This setting is also related to the Outputs Mode on page 18 .	
Factory Settings	Tick selection ON or OFF, ON= Reset all settings to their default values.	
Clock Settings	X-Position (Left to right) = 000 to 110 Y-Position (Lower to Upper) = 000 to 135 Set Hours Set Minutes Clear Seconds	
Multi Screen Mode	This selection relates to the HDMI outputs 1 (=W1) and 2 (=W2). A : W1 = PGM + PVW + 3 IN ; W2 = 9 IN B : W1 = PGM + PVW + 12 IN ; W2 = PGM C : W1 = PGM + PVW + 8 IN ; W2 = PGM D : W1 = PGM + PVW + 12 IN ; W2 = W1 E : W1 = PGM + PVW + 8 IN ; W2 = W1 See page 11 also.	
GPI Settings	Input Select = Chosen input number Time Delay = In frames between 1 to 75	
Countdown Timer Settings	Each input can selected for Count Down ON or OFF. If Count Down is ON then the Down Counter value is set in minutes and seconds (MM:SS) - Max.= 1 Hour or 60:00, Default = 15 Seconds or 00:15	
Audio Associations	Input channels 1-12, Value 1-12 (used to choose an embedded audio source – see page 29 for more details)	
Multi Screen Audio	Tick selection of Program or Preview audio on the HDMI outputs.	

SE-2800 Video Layers

The SE-2800 is a Standard Definition or High Definition Digital Video Switcher and as well as mixing video and audio sources it has additional functions such as Picture In Picture (PIP), DSK LUMA KEY and LOGOs.

Before attempting to use the SE-2800's PIP, DSK LUMA KEY and LOGO functions it may help to first understand the order of the video layers at the SE-2800 Program (PGM) outputs.

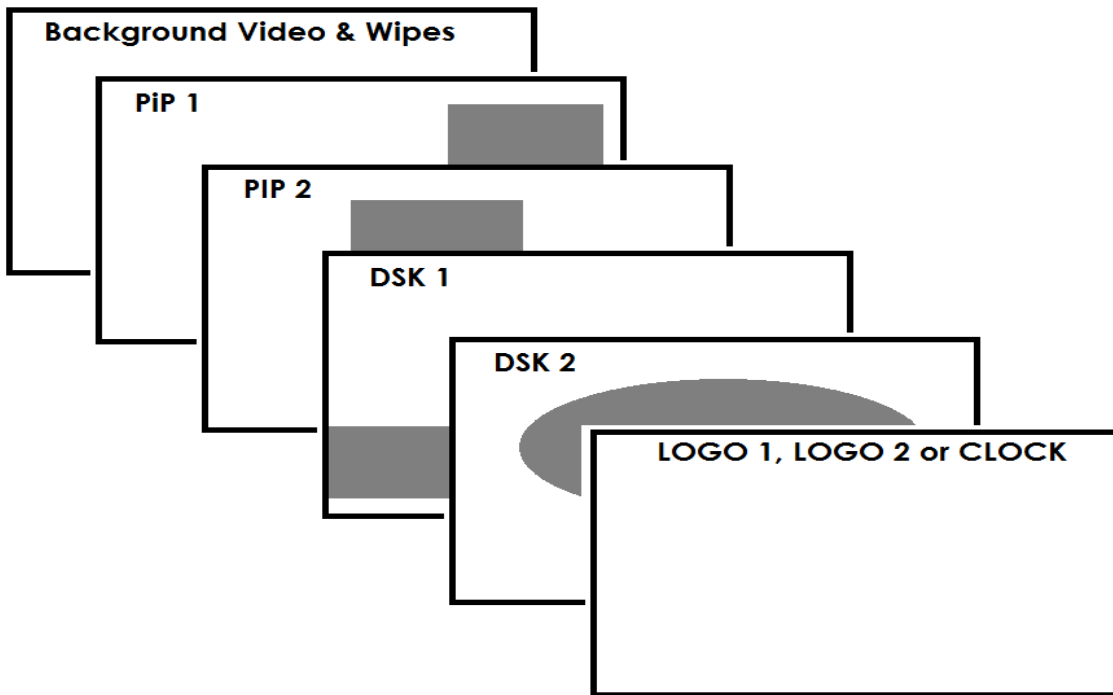

The **Background video layer** is the normal video layer when mixing and switching with the SE-2800. It occupies the whole screen area of the Program output. This layer can be hidden or part hidden by the PIP, DSK and LOGO layers in front of it.

The **PIP 1 layer** does not occupy the whole screen and is shown in front of the Background video layer when enabled. In some setups the PIP 1 image can be hidden behind the PIP 2 image. This is not a fault. Change the position or size of the PIP 1 or PIP 2 image if required.

The **PIP 2 layer** does not occupy the whole screen and is shown in front of the Background video and PIP 1 layers when enabled. In some setups the PIP 1 image can hide the PIP 2 image. Change the position or size of the PIP 2 or PIP 1 image if required.

The **DSK 1 layer** can occupy the whole screen. If set up incorrectly this layer can stop the video layers behind it from being seen properly. Re-adjust your DSK 1 settings or switch off the DSK1 function on the SE-2800 to restore the video behind it.

The **DSK 2 layer** can occupy the whole screen. If set up incorrectly this layer can stop the video layers behind it from being seen properly. Re-adjust your DSK 2 settings or switch off the DSK1 function on the SE-2800 to restore the video behind it.

The **LOGO and Clock layer** does not occupy the whole screen and all other layers are visible through it. A logo if positioned incorrectly can partially hide an important part of the video, PIP or CG LUMA KEY layers. Typically logos or station ID bugs are placed in a corner of the screen.

NB: Where possible prepare and position the upper video layer elements in advance of the live production starting to avoid them appearing on the program output incorrectly.

Most broadcast networks have guidelines and advice on the use of video, images, music, logos and on screen text so it is best to check beforehand when planning a production. Do not use copyright protected content until you have the relevant permissions. Information on royalty free video, images and music is widely available, speak to your local dealer or search for advice on the internet.

PIP – Picture In Picture function

The SE-2800 Picture in Picture function allows you to place one or two smaller PIP images over a chosen full size background image. The smaller PIP images can be set to pre-defined sizes and positioned almost anywhere within the Preview/Program screen area. These PIP windows can also have a coloured border applied, and can be brought into the production with a default PIP dissolve transition.

PIP Settings

Before trying to activate the PIP function it is best to understand how to set up or choose the right options for your production. Press the **ENTER Key** in the **MENU** area of the SE-2800 keyboard. Navigate to the **PIP Settings** option using the down arrow key. The PIP menu options provided here are:

PIP Settings	Position PIP1	X-Position (Left to right) = 000 to 097 Y-Position (Lower to Upper) = 000 to 108
	Size PIP1	PIP Size = 1 (small) to 33 (large)
	Border PIP1	Border Size = 0 (OFF), 1 (Thin) to 15 (Thick)
	Position PIP2	Border Color = 1 to 8 (user defined colours)
	Size PIP2	1=Yellow, 2=Cyan, 3=Green, 4=Magenta, 5=Red, 6=Blue
	Border PIP2	

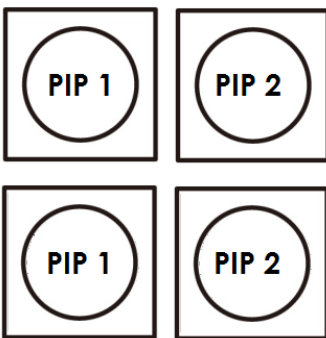

PIP Preset and PIP Program

When looking at the top right corner of the SE-2800 Control Panel / Keyboard there are four PIP keys. These are labelled Program and Preset.

The upper PIP1 and PIP2 keys relate to activating Picture In Picture images on the Program outputs.

The lower PIP1 and PIP2 keys relate to activating Picture In Picture images on the Multi-view or Preview outputs.

Assigning a video source input to a PIP

Using the lower PIP1 or PIP2 buttons you can assign a selected video input to the chosen PIP video layer.

- 1) First press and hold down the required PIP button on the lower row. The Preset row of input sources will light.
- 2) While still holding down the PIP button, press to select the required input from the Preset row.
- 3) The input will flash to confirm it is selected.

This selection will also be confirmed on the HDMI Multi-view, with a P1 or P2 label shown next to the selected input image.

DSK function (CG / LUMA KEY)

The SE-2800 has two Down Stream Keyers (**DSK1**, **DSK2**). This means it is able to take a key source video input and replace the white or black parts of this image with the video from another source. If the input video carries an alpha channel it is also possible to key in this way too.

DSK Settings

Before trying to activate the DSK function it is best to understand how to set up or choose the right options for your production well in advance of the production.

Press the **ENTER Key** in the **MENU** area of the SE-2800 keyboard. Navigate to the **DSK Settings** option using the down arrow key. The DSK menu options provided here are:

DSK Settings	Titles 1 (DSK1) Titles 2 (DSK2)	Titles + a-CH mode (alpha channel mode) Luma Key mode Luma Key Level 0 (black) to 255 (white)
---------------------	--	--

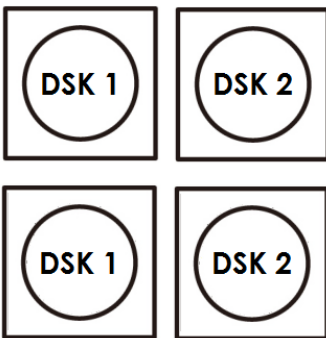

DSK Preset and DSK Program

When looking at the top right corner of the SE-2800 Control Panel / Keyboard there are four DSK keys. These are labelled Program and Preset.

The upper DSK1 and DSK2 keys relate to activating Down Stream Keying on the Program outputs.

The lower DSK1 and DSK2 keys relate to activating Down Stream Keying on the Multi-view or Preview outputs.

Assigning an input to a DSK channel for keying

Using the lower DSK1 or DSK2 buttons you can assign a selected video input to the chosen DSK video layer.

1. First press and hold down the required DSK button on the lower row. The Preset row of input sources will light.
2. While still holding down the DSK button, press to select the required input from the Preset row.
3. The input will flash to confirm it is selected.

This selection will also be confirmed on the HDMI Multi-view, with a T1 or T2 label shown next to the selected input image.

Example SE-2800 and CG-350 Set Up

An example set up for the **DSK1 and DSK2** feature would be to supply separate HD-SDI **Key** and **Fill** signals from a **Datavideo CG-350 Character Generator PC**. This PC can provide CG overlays of text and graphics from the outputs of a 3rd party PCIe video card such as **Blackmagic Design's Decklink HD Extreme 3D+ card**.

1. Ensure the **CG-350 software** is set up for **External key** in its settings.
2. The **Key** signal from the Decklink card is then fed to **input 9** on the SE-2800 (see diagram below). Press and hold down the DSK1 button on the lower row. The Preset row of input sources will light, choose input 9. The input will flash to confirm it is selected. This selection will also be confirmed on the HDMI Multi-view, with a T1 shown next to the selected input image.
3. The **Fill** signal from the Decklink card is then fed to **input 10** on the SE-2800 (see diagram below).
4. Now go into the multi-view menu by pressing ENTER on the SE-2800 keyboard. Navigate to **DSK SETTINGS > TITLES 1** and choose **TITLES + a-CH MODE**. The SE-2800 will automatically use inputs 9 and 10 as key and fill.

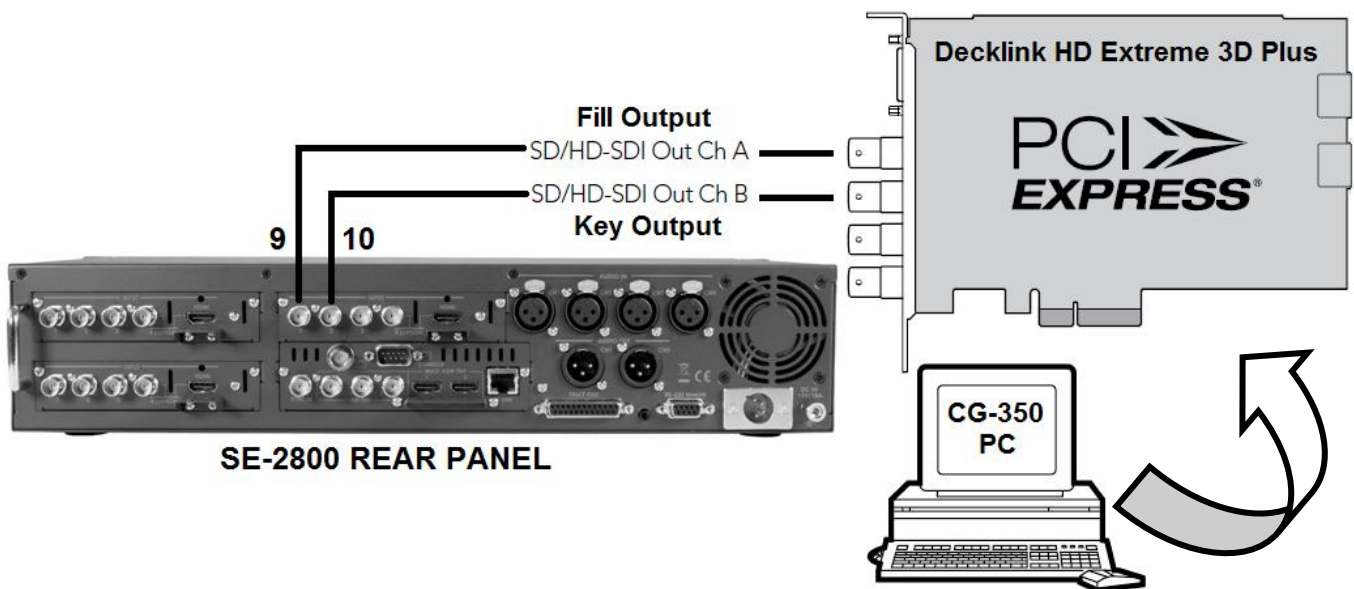

If you have two CG-350 computers then the same steps can be used for DSK2 set up but using inputs 11, 12 and the second CG-350 PC.

If you have an SE-2800 with only eight input channels, then you could set up a single key and fill DSK, using inputs 5 and 6. This leaves six other video input channels to work with.

If you have an SE-2800 with only eight input channels and need to use two DSKs then separate Luma key set ups can be created using the instructions on **page 22**. This leaves six other video input channels to work with.

Switcher configuration using a computer – SEConfig software

It is possible to configure the SE-2800 with a Windows 7 computer using an Ethernet connection.

1. Switch off or shut down the SE-2800 and Computer in the normal way.
2. Connect the Ethernet cable between the SE-2800 rear panel and the Windows 7 Computer.
3. Turn on the Windows 7 Computer.
4. **Install the supplied SEConfig software on to a Windows 7 Computer.**
5. Double click the **SEConfig** DV icon to launch the application.



6. If you immediately get an error window, do not worry, click **OK**.

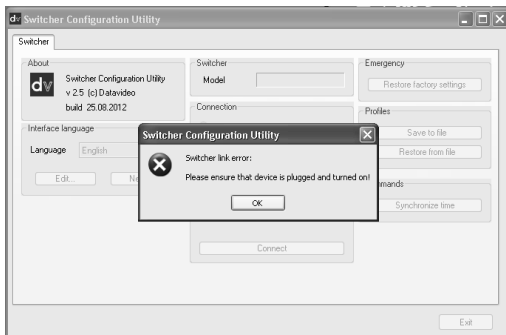

7. Now Press **PC Control button** so it is **ON** in the **MENU area** of the SE-2800 keyboard.

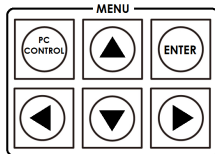

8. Select **Ethernet** to display the Computer’s IP Address. Click the **Find button** to find and display the SE-2800 Switcher’s IP Address in the drop down list. The first three numbers in both IP addresses should match. See below example.

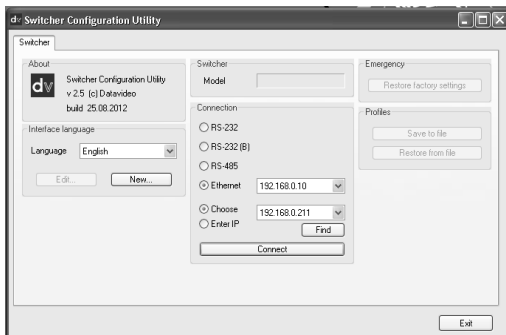

9. Click **Connect** and additional function tabs will become available at the top of the application window. These are; switcher, settings, input settings, multi screen window signs (source labels), still pictures, logos, dynamic logo, multi screen A, multi screen B+D and multi screen C+E

Switcher tab

This first tab can be used to choose the method of connection between the computer and the switcher. In this case the SE-2800 is connected using selected Ethernet IP addresses.

Note that the first three numbers in the IP addresses of the switcher and computer should be the same. The last number in each IP address should be unique.

If you are connecting for the first time you may be asked by the computer to change the firewall setting to allow this application to connect to the switcher.

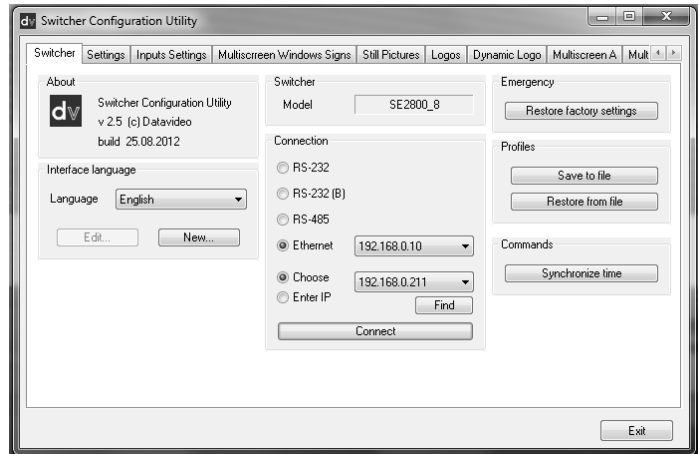

Profiles

It is possible to store the current profile or settings of the switcher to your computer. This file can then be restored to the machine at a later date allowing simple configuration of the unit. Depending on the included levels of the profile this save process may need some time to complete.

Settings tab

The settings tab is another way to change the menu settings of the switcher. The options may appear in a slightly different order to those in the onscreen menu described on **page 17**.

Each menu option can be expanded by clicking on the plus sign in the left hand pane. The right hand pane shows any values which can be changed.

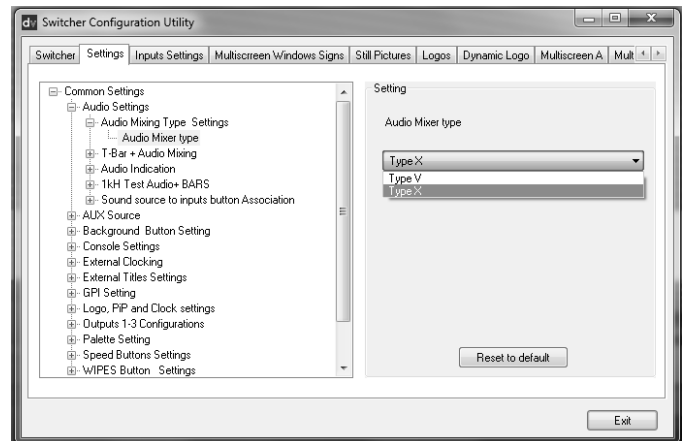

Input settings tab

The Input settings tab allows each input to be configured from the computer.

Note due to the design of the switcher different inputs may have more or less options as they are not all the same. See **page 9**, Video Input Module.

Each menu option can be expanded by clicking on the plus sign in the left hand pane. The right hand pane shows any values which can be changed.

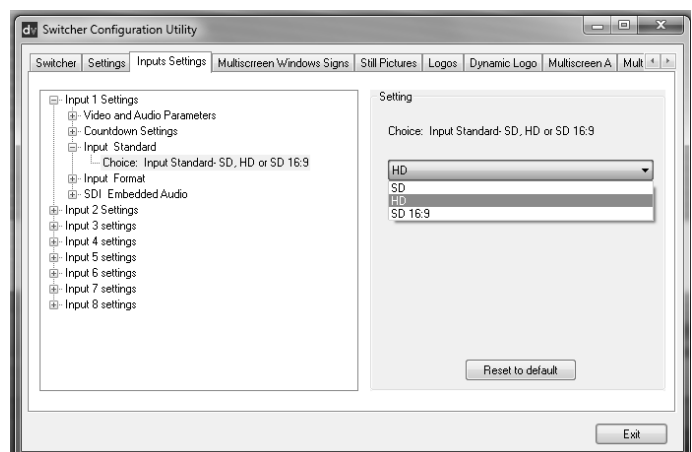

Multi screen window signs (labels) tab

This tab allows the user to rename the input source labels on the HDMI multi view.

The **READ** button can be used to load the current label of a selected input into the application window on the left.

This selected label can then be edited using the **TEXT** box. If required the font and colour of the text can also be changed.

The **WRITE** button can then be used to write the new label text into the switcher's memory.

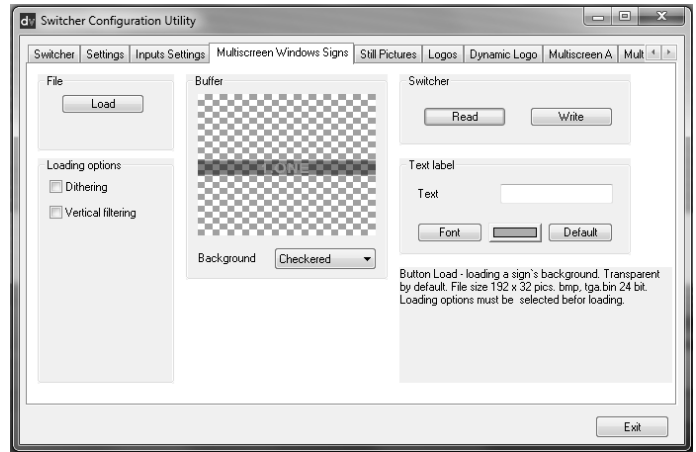

Still pictures (FS) tab

Each switcher has the ability to store still pictures in its frame stores. If the switcher has eight inputs it has the ability to store eight still pictures. Twelve pictures can be stored if the unit has twelve inputs.

See **FS button** on page 16 also.

The **LOAD** button can be used to browse for a picture stored on the computer. This picture is then loaded into the application window.

The **WRITE** button can then be used to save the new picture into a selected frame store on the switcher.

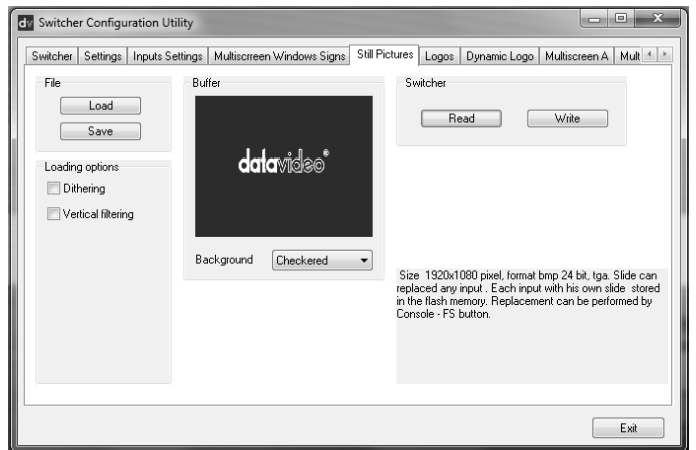

Logos tab

The SE-2800 can store up to seven still logos in its memory.

Using the logos tab you can use the **LOAD** button to browse for a logo stored on the computer. This logo is then loaded into the application window.

The **WRITE** button can then be used to save the new logo into a selected logo store on the switcher.

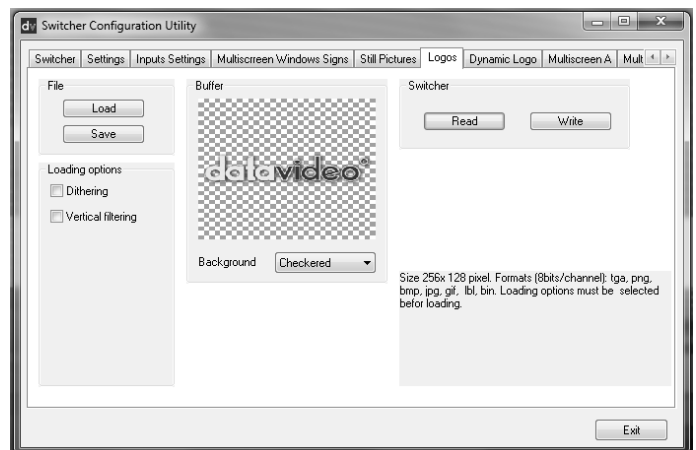

Dynamic Logo tab

The SE-2800 can store one dynamic moving logo in its memory. The dynamic logo can be a targa (TGA) sequence, GIF or AVI. It must be no longer than 75 frames/images long.

Using the Dynamic logo tab you can use the **LOAD** button to browse for a logo sequence of images stored on the computer. This logo sequence is then loaded into the application window.

The **WRITE** button can then be used to save the new logo sequence into the dynamic logo store on the switcher.

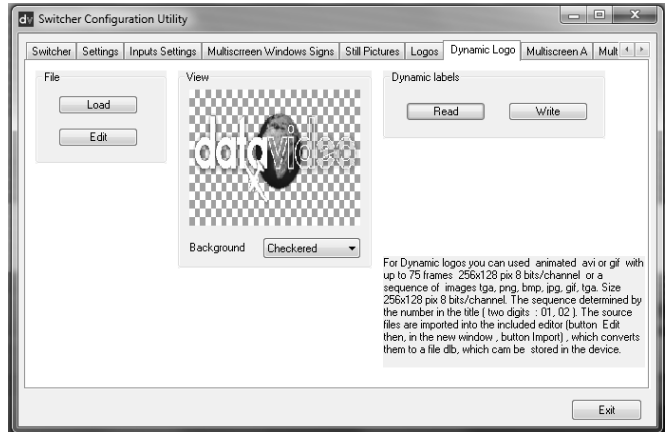

Multi screen A tab

Multi screen B+D tab

Multi screen C+E tab

These three tabs are used to write new Multi screen layouts to the switcher in order to change the HDMI multi-view layouts as described on **page 11**.

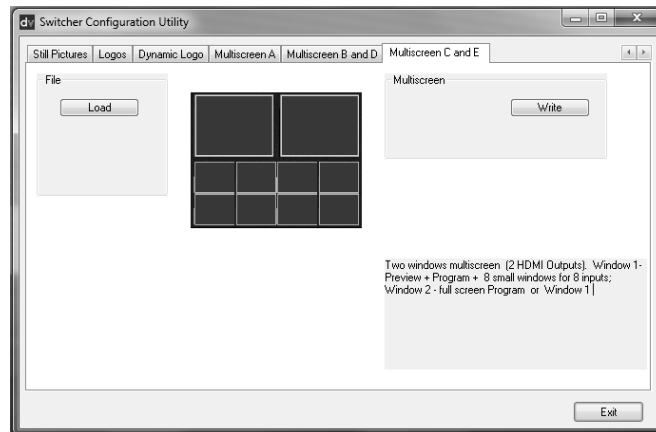

NOTE: Only change these layouts with guidance from your local Datavideo office as attempting to edit or load your own layouts may result in a poor outcome or a non-responsive switcher.

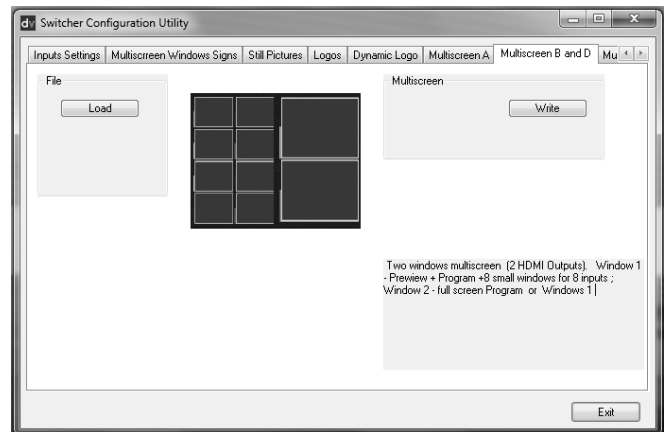
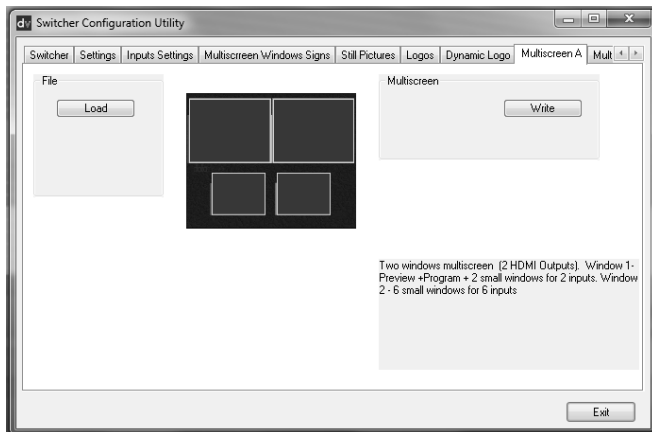

Controlling the switcher with a computer – SE Remote software

It is possible to control the SE-2800 with a Windows 7 computer using an Ethernet connection. The SE Remote software supplied with the switcher needs to be installed on the computer first. The SE-2800 then needs to be placed into PC Control mode. To do this press the **PC Control button** on the SE-2800 Control Panel. Once launched the Remote software displays an image of the SE-2800's keyboard as shown below. Any active functions or selections will be shown with a red button or key. These buttons or keys can be clicked with a mouse or alternatively you could use a touch screen monitor.



Software based Macro functions

It is possible to record a Macro type playlist to the computer when using the SE Remote software. This Macro function allows these pre-recorded keyboard actions or selections to be played back within a project where timing is important or where the same steps are repeated throughout the production. The Macro function buttons are **REC**, and **PLAY**. These buttons are located just above the T-Bar in the SE Remote display above.

REC & PLAY functions

Left mouse click the grey REC button and it will light up red. All of your actions when using the Remote Console will now be recorded to file. The only action that will not be recorded is the T-Bar, use the CUT or AUTO TAKE buttons instead. The function buttons just above the T-Bar as listed on this page are also ignored.

Click the red REC button again and a save window will appear. You can now save the recorded actions as a macro text file to a chosen location on the computer.

Click the grey PLAY button and a load file window will appear. You can now browse to and load a macro text file. When you load a file the recorded actions will begin to play back until the end of the file.

TIME function

Mouse clicking on this button will synchronize the time on the switcher to the current time on the computer.

SET function

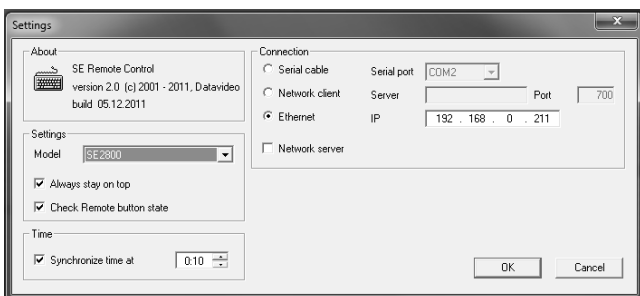

Used to set up the IP address of the connected switcher.

If unknown, the switcher's IP address may be found by using the **SEConfig software** first. The **Find button** within the SEConfig software will help confirm the IP address of the switcher.

NOTE: It is not possible to run the SEConfig and Remote software applications at the same time.

AUDIO function

Overview

The SE-2800 has a simple, cost effective, audio switcher built in. The SE-2800 has the ability to take audio from several sources either XLR analogue, SDI and/or HDMI inputs. The audio can be embedded onto the HDMI and SDI outputs and/or fed to the analogue XLR audio connections.

When using the audio functions of the SE-2800 switcher you may de-embed audio from selected SDI or HDMI inputs and then output this audio from the XLR outputs of the switcher to a separate audio mixer like the Datavideo AM-100 audio mixer.

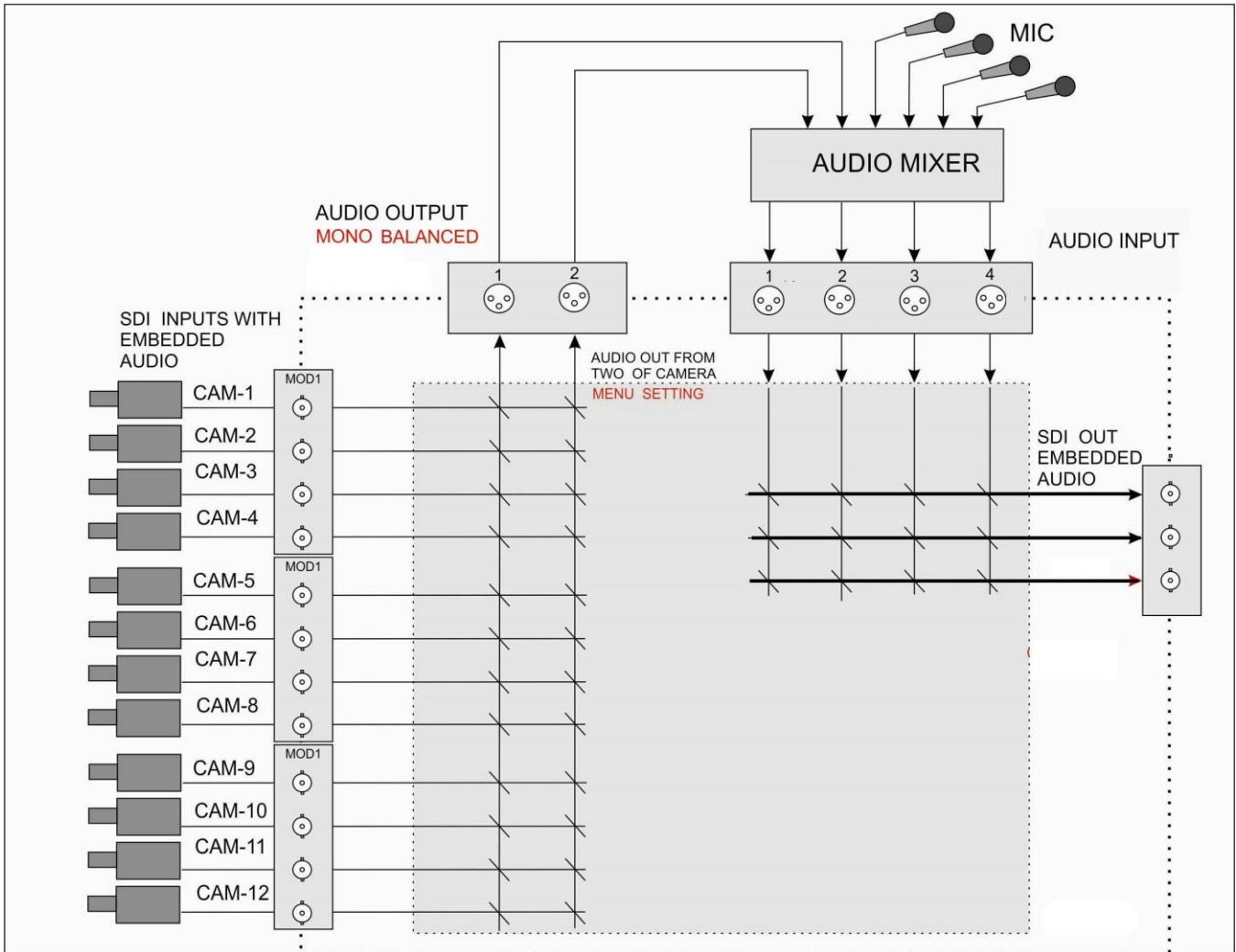

Once the audio is mixed externally with any microphones or audio sources it can then be fed back into the SE-2800 on the analogue XLR inputs. The SE-2800 can then embed this externally mixed audio on to the Program SDI and HDMI outputs.

Audio Menu Options – De-embedding SDI or HDMI audio

Using the following SE-2800 menu options audio can be selected from the SDI or HDMI video inputs.

SDI Embedded Audio Set.	Inputs 1 to 12	User choice of	Group 1,2,3 or 4 Pair 1 or 2
HDMI in Embedded Audio Pair	Input 4,8 or 12	User choice of	Group 1,2,3 or 4

As each SDI / HD-SDI source can have up to sixteen channels of audio, and HDMI eight channels, we need to choose the audio channels with the options above and by the following reference tables.

SDI Embedded Audio			
Group	Stereo Pair	Channel	Number
Group 1	Stereo pair 1	left	1
		right	2
	Stereo pair 2	left	3
		right	4
Group 2	Stereo pair 3	left	5
		right	6
	Stereo pair 4	left	7
		right	8
Group 3	Stereo pair 5	left	9
		right	10
	Stereo pair 6	left	11
		right	12
Group 4	Stereo pair 7	left	13
		right	14
	Stereo pair 8	left	15
		right	16

In some cases there may only be two channels of audio associated with the video: Group1, Stereo Pair 1.

HDMI Embedded Audio		
Stereo Pair	Channel	Number
Stereo pair 1	left	1
	right	2
Stereo pair 2	left	3
	right	4
Stereo pair 3	left	5
	right	6
Stereo pair 4	left	7
	right	8

Audio Menu Options – Monitoring the audio levels

The SE-2800 can confirm the incoming audio levels by showing audio peak meters on the HDMI multi-view.

Audio Level is shown	Tick selection ON or OFF
-----------------------------	--------------------------

It is also possible to hear the preview or program audio from the multi-view HDMI outputs using the menu option below.

Multi Screen Audio	Tick selection of Program or Preview audio on the HDMI outputs.
---------------------------	---

Audio Menu Options – Changing the audio input level

The SE-2800 can change the incoming audio level on the video inputs by adjusting the following menu option.

Input Audio Settings	Level Nominal	Range -60 to +60 Resets value to zero
-----------------------------	----------------------	--

The audio level can also be changed at the external audio mixer if one is used - see our example on **page 29**.

Changing the audio output level

The SE-2800 can change the program output audio levels by using the following keyboard buttons

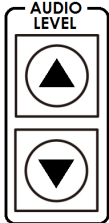

The AUDIO LEVEL buttons are related to the level of the Program audio output, whether SDI embedded or analogue XLR.

Working with a fixed or single audio source

Example 1:

We have two mono mics (channels 1 & 2) connected to a HD camera. These embedded audio channels are then output from this camera, HD-SDI, to the SE-2800 switcher. If we want to only hear these two audio channels regardless of the video channel used then we would set up the switcher in the following way.

Press the **ENTER** key in the **MENU** area of the SE-2800 keyboard to display the on screen menu on the HDMI 1 output.

Change the **Audio Association** settings in the menu system to show a value of 1 for each video input channel. Press the **ENTER** key to store the audio values chosen for each video input.

Change the **SDI Embedded Audio** setting in the switcher's menu system to show a value of Group 1 and Pair 1. Press the **ENTER** key to store the audio values chosen for each video input.

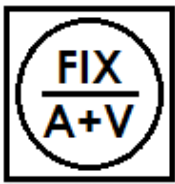

Now exit the menu by pressing any wipe key and look at the **FIX / A+V button** in the wipes area of the keyboard.

Select the **AUDIO FIXED** status with this button when looking at the status area of the HDMI multi-view. **The button will be backlit red.** The status area is located just below or near the Preview image on the HDMI multi-view monitor.

Switching between different embedded audio sources

Example 2:

We have two mono mics each connected to a different HD camera. The embedded audio is then output from each camera, HD-SDI, to the SE-2800 switcher. If we want to hear the audio from each camera as the video channels are switched, **audio follows video**, then we would set up in the following way.

Press the **ENTER** key in the **MENU** area of the SE-2800 keyboard to display the on screen menu on the HDMI 1 output.

Change the **Audio Association** settings in the menu system to show a value of 1 for each video input channel that is associated with audio input 1. Then change to a value of 2 each video input channel that is associated with audio input 2. Press the **ENTER** key to store the audio values chosen for each video input.

Change the **SDI Embedded Audio** setting in the switcher's menu system to show a value of Group 1 and Pair 1. Press the **ENTER** key to store the audio values chosen for each video input.

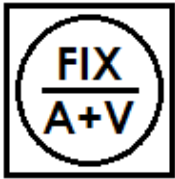

Now exit the menu by pressing any wipe key and look at the **FIX / A+V button** in the wipes area of the keyboard.

Select the **AUDIO-F-VIDEO** status with this button when looking at the status area of the HDMI multi-view. The button will be off. The status area is located just below or near the Preview image on the HDMI multi-view monitor.

When switching between the video sources the audio sources will also change. We can choose how the audio will change sources, whether it be a clean cut (immediate switch) or some sort of transitioned change (cross fade or fade out & in). To do this we would need to set up with the following menu options.

Auto Audio Mixing Type	User choice of	X type or V type Tick selection	X type = A/B cross fade V type = Fade out A then fade in B
T-Bar Audio Mixing Type	Tick selection of	Follow auto audio mixing type (use above option) By the end (clean cut or immediate audio switch)	

GPI / GPO Connections

The SE-2800 can be controlled externally via a simple contact closure GPI (General Purpose Interface) switch. This could be a push button, foot switch or any relay or any circuit that is able to provide a simple contact closure.

The GPI interface is a 3.5mm Jack Socket which is situated on the rear panel of the SE-2800. Contact closure between the Outer and Inner contacts on the jack plug will trigger a user selected event. Power is supplied by the SE-2800 and is less than 5V DC.

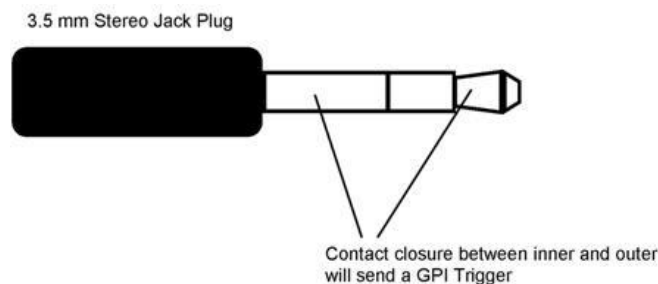

This GPI socket can also be used as a GPO socket to trigger record or playback events with other equipment such as the Datavideo HDR-70 recorder.

SAFETY FIRST The cabling required needs to be designed specifically to connect the SE-2800 to the chosen record or playback device as they are not all the same. The cabling required can be made by yourself or a competent technician. Please speak with your Dealer or local Datavideo office to get further help and advice.

SE-2800 Tally Outputs

The SE-2800 has a D-sub 25 pin female tally output port. These connections provide bi-colour tally information to a number of other Datavideo products, such as the ITC-100 eight channel talkback system and the TLM range of LCD Monitors.

These ports are open collector ports and as such do not provide power to tally light circuits.

Dielectric strength: Max. DC 24V

Current: Max. 50mA

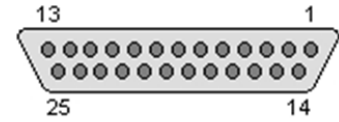

(D-sub 25-Pin Female)

The pin outputs are defined as follows:

Pin No.	Signal name	Input/Output	Description of signal
1	Program 1	Open collector output	Tally output of input video Program 1
2	Program 2	Open collector output	Tally output of input video Program 2
3	Program 3	Open collector output	Tally output of input video Program 3
4	Program 4	Open collector output	Tally output of input video Program 4
5	Program 5	Open collector output	Tally output of input video Program 5
6	Program 6	Open collector output	Tally output of input video Program 6
7	Program 7	Open collector output	Tally output of input video Program 7
8	Program 8	Open collector output	Tally output of input video Program 8
9	Program 9	Open collector output	Tally output of input video Program 9
10	Program 10	Open collector output	Tally output of input video Program 10
11	Program 11	Open collector output	Tally output of input video Program 11
12	Program 12	Open collector output	Tally output of input video Program 12
13	GND	Ground	Ground
14	Preset 1	Open collector output	Tally output of input video Preset 1
15	Preset 2	Open collector output	Tally output of input video Preset 2
16	Preset 3	Open collector output	Tally output of input video Preset 3
17	Preset 4	Open collector output	Tally output of input video Preset 4
18	Preset 5	Open collector output	Tally output of input video Preset 5
19	Preset 6	Open collector output	Tally output of input video Preset 6
20	Preset 7	Open collector output	Tally output of input video Preset 7
21	Preset 8	Open collector output	Tally output of input video Preset 8
22	Preset 9	Open collector output	Tally output of input video Preset 9
23	Preset 10	Open collector output	Tally output of input video Preset 10
24	Preset 11	Open collector output	Tally output of input video Preset 11
25	Preset 12	Open collector output	Tally output of input video Preset 12

Example of tally connections

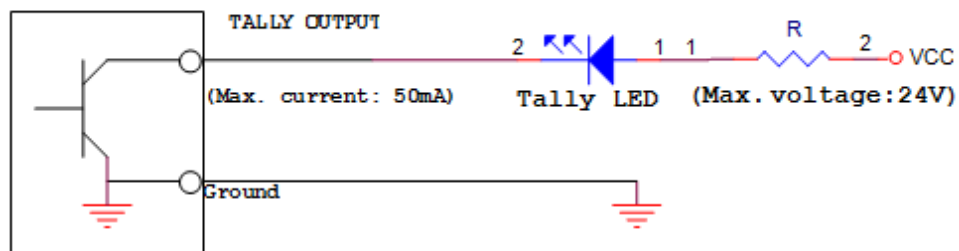

How to update the SE-2800 Firmware

From time to time Datavideo may release new firmware to fix reported bugs in the current SE-2800 firmware or to add a new feature. Customers can update the SE-2800 firmware themselves if they wish or they can contact their local dealer or reseller for assistance should they prefer this method.

This page describes the firmware update process for the complete unit, if you have all the items required it should take **approximately 1 hour 20 minutes total time to complete**.

Once started **the update process should not be interrupted in any way** as this could result in a non-responsive unit.

As well as a working SE-2800 you will need:

- The latest Firmware update file for the SE-2800.
This can be obtained from your local Datavideo office or dealer.
- The SE-2800 power supply.
- The SEConfig software supplied with the switcher.
- A Windows 7 computer with an Ethernet port.
- An Ethernet cable.

To update the SE-2800 firmware:

1. Switch off or shut down the SE-2800 and Computer in the normal way.
2. Connect the Ethernet cable between the SE-2800 rear panel and the Windows 7 Computer.
3. Turn on the Windows 7 Computer.
4. Unzip the firmware update folder to the Computer Desktop so the file within it is easy to locate.
5. Double click the firmware update icon to launch the Flash Update Utility.



6. Confirm the supported devices list says **SE-2800** then click **NEXT**.

7. The following window will be displayed.

Select **Device is connected via Ethernet** then click **NEXT**.

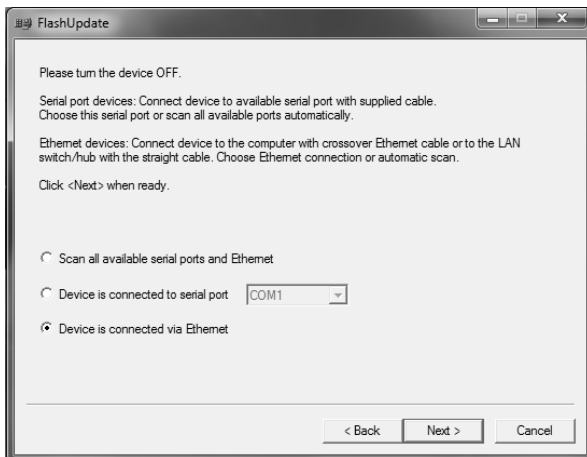

8. The following window will be displayed.

You can now **POWER ON** the **SE-2800** and it will be discovered by the Computer.

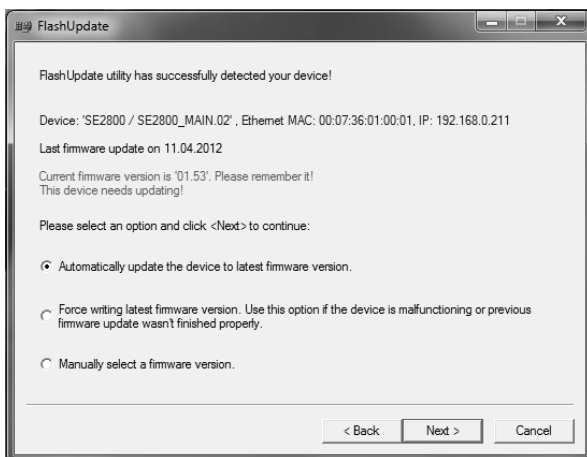
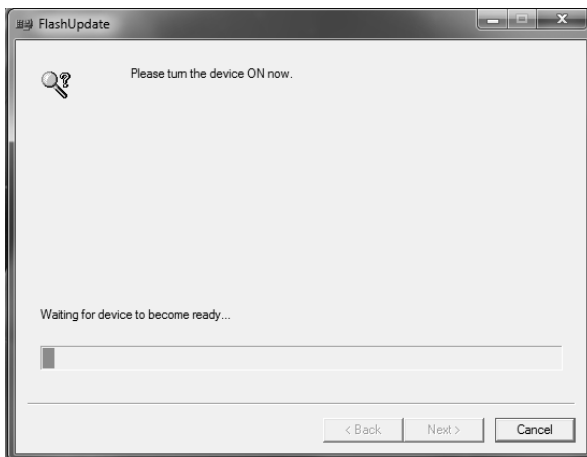

9. Select **Automatically update the device to latest firmware version** then click **NEXT**.

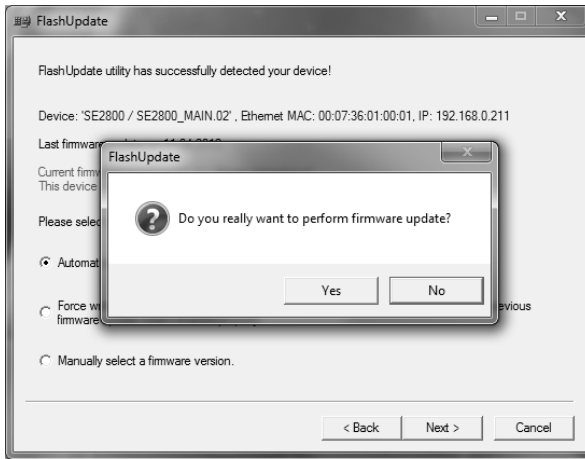

10. Click the **Yes button** to confirm you wish to perform the firmware update.

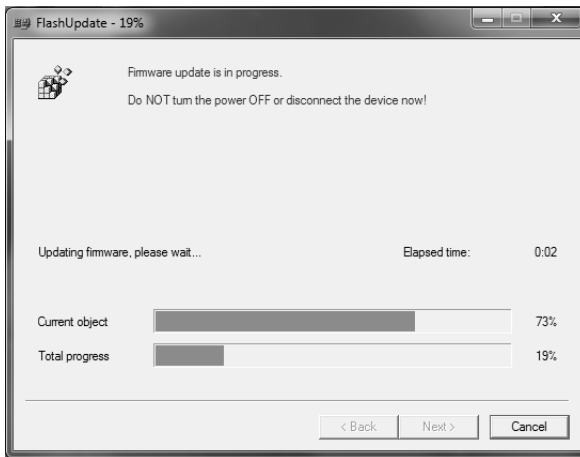

11. The update process will begin and two progress bars will be shown. The lower bar, Total Progress, will take around 15 minutes to complete.

12. Once this process is complete **close the application** and **power cycle the SE-2800**.

13. When the SE-2800 has restarted. **Install the SEConfig software on to the Computer**.

14. Double click the **SEConfig** dv icon to launch the second part of the update process.



15. If you immediately get an error window, do not worry, click **OK**.

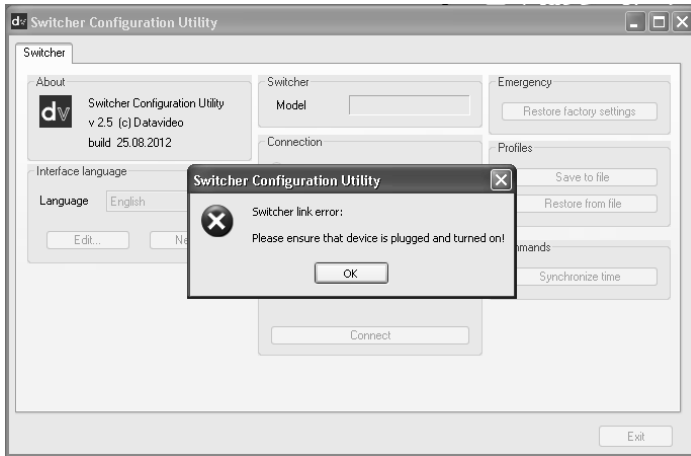

16. Now **Press PC Control button** so it is **ON** in the **MENU area** of the SE-2800 keyboard.

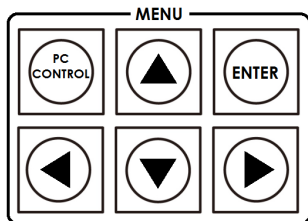

17. Select **Ethernet** to display the Computer's IP Address. Click the **Find button** to find and display the SE-2800 Switcher's IP Address in the drop down list. The first three numbers in both IP addresses should match. See below example.

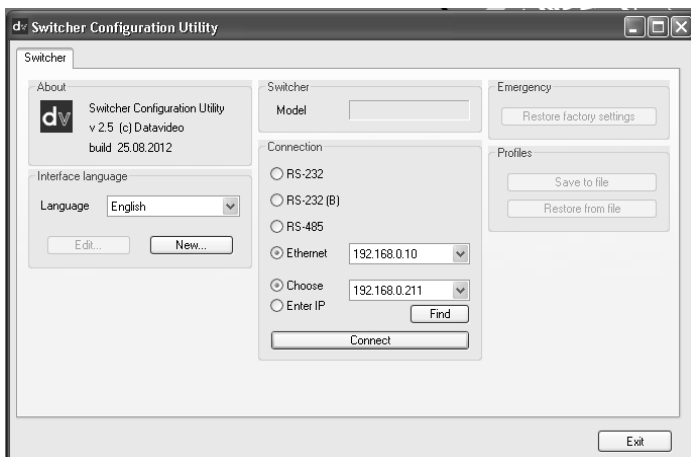

18. Click **Connect** and then click **Restore Factory Settings** in the top right hand corner. The process will take approximately 45 minutes to complete.
19. The next step will be to re-calibrate the SE-2800 T-Bar to get it working again.

How to Re-calibrate the SE-2800 T-Bar

After a firmware update of the switcher it will be necessary to re-calibrate the T-Bar to get it working correctly.

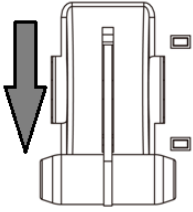

1. Move the **T-Bar** to its **lowest position**.

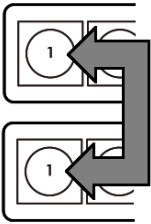

2. **Power OFF** the SE-2800 switcher.
3. Press and **hold down button 1** on both the **Program and Preset** rows of the switcher's keyboard.

4. **Power ON** the SE-2800 switcher while **still holding down the buttons** in step 3.

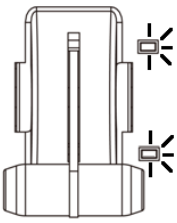

5. The switcher will start but the keyboard lights will remain dead except for the T-Bar progress LEDs. When these **LEDs flash ON and OFF** release the buttons from step 3.

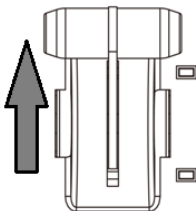

6. Move the **T-Bar** to its **highest position** and then press the **CUT button**.

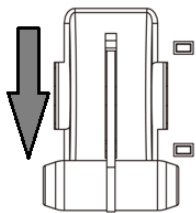

7. Move the **T-Bar** back to its **lowest position** and then press the **AUTO TAKE button**.



8. To exit the calibration procedure press the **CLOCK button**.

9. Ensure the **TIMER button** is **OFF**.

10. Test the T-Bar.
If necessary change the **T-Bar Mode** in the **MENU options**.

How to change the SE-2800 video standard

As well as a working SE-2800 you will need:

- The latest Firmware update file for the SE-2800.
This can be obtained from your local Datavideo office or dealer.
- The SE-2800 power supply.
- The SEConfig software supplied with the switcher.
- A Windows 7 computer with Ethernet port.
- An Ethernet cable.

To change the SE-2800 video standard:

1. Switch off or shut down the SE-2800 and Computer in the normal way.
2. Connect the Ethernet cable between the SE-2800 rear panel and the Windows 7 Computer.
3. Turn on the Windows 7 Computer.
4. Unzip the firmware update folder to the computer desktop so the file within it is easy to locate.
5. Double click the firmware update icon to launch the process.



6. Confirm the lower box says **SE-2800** then click **NEXT**.

7. The following window will be displayed.
Select **Device is connected via Ethernet** then click **NEXT**.



8. The following window will be displayed.
You can now **POWER ON** the **SE-2800** and it will be discovered by the Computer.



9. Select **Manually select a firmware version** then click **NEXT**.



1. Click the **Yes button** to confirm you wish to proceed.

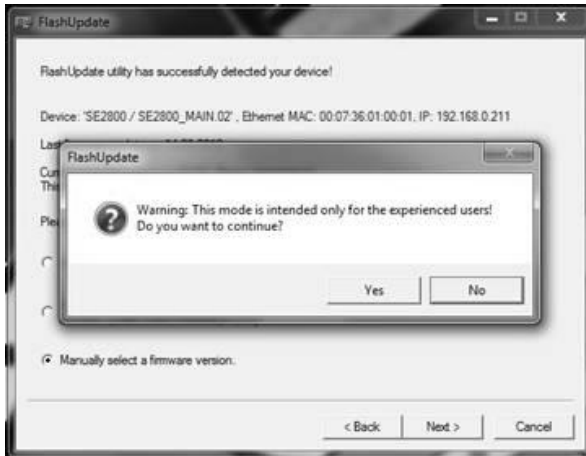

The Video Standard can now be changed from 1080i 60 to 1080i 50 or vice versa.

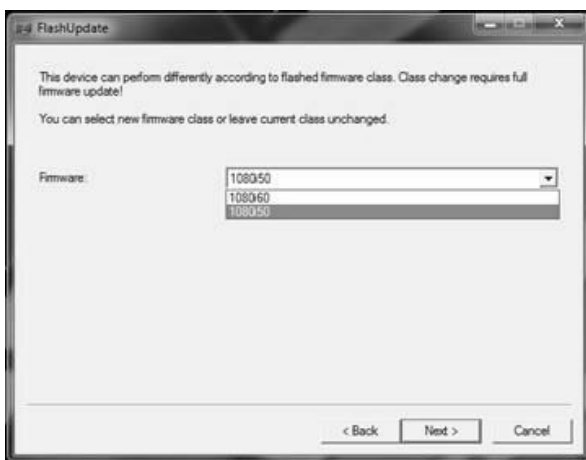

13. You will now see which firmware elements are selected to be changed.

14. Click **NEXT** at the bottom of the flash update window.
Then click the **Yes button** to confirm you wish to proceed.

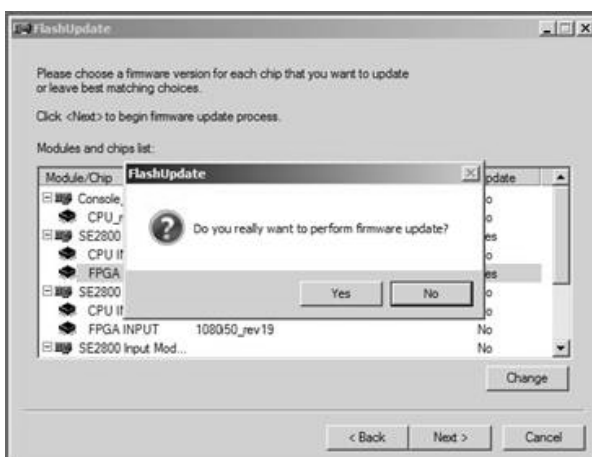

15. Wait for the update to progress.

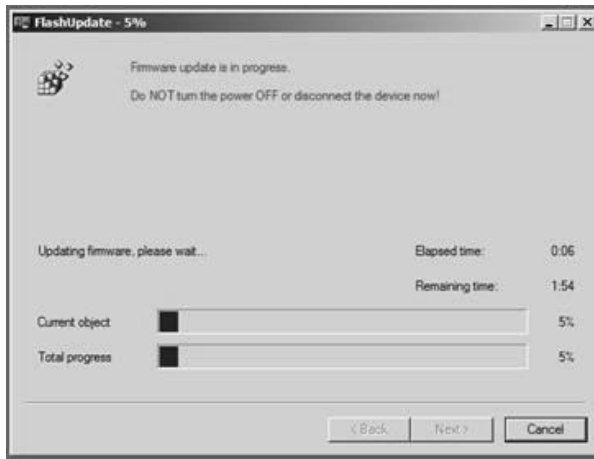

16. Once the process is finished re-start the switcher by powering it off and back on again.

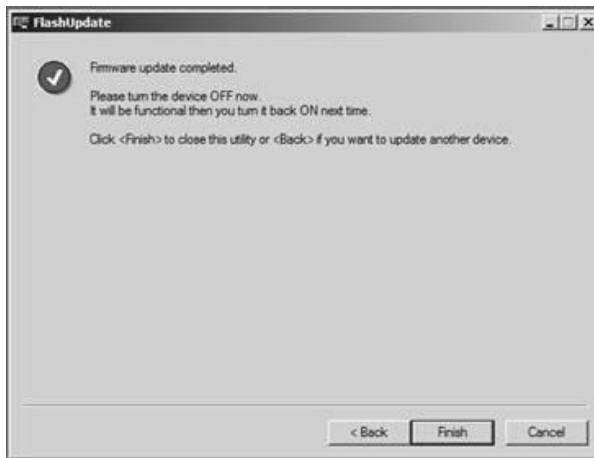

17. Check the resolution at the output now matches the desired 1080i 50 standard.

18. Check the T-Bar and other functions still operate correctly.

Example SE-2800 Set Up

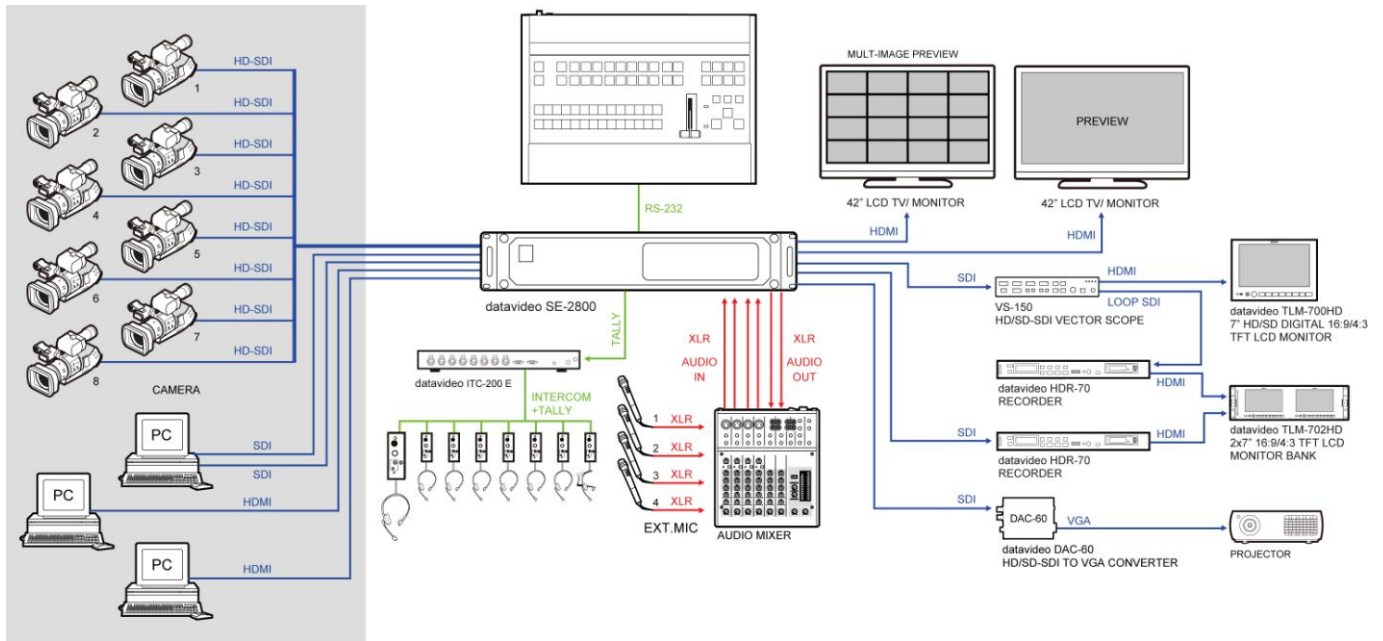

Dimensions

All measurements in millimetres (mm).

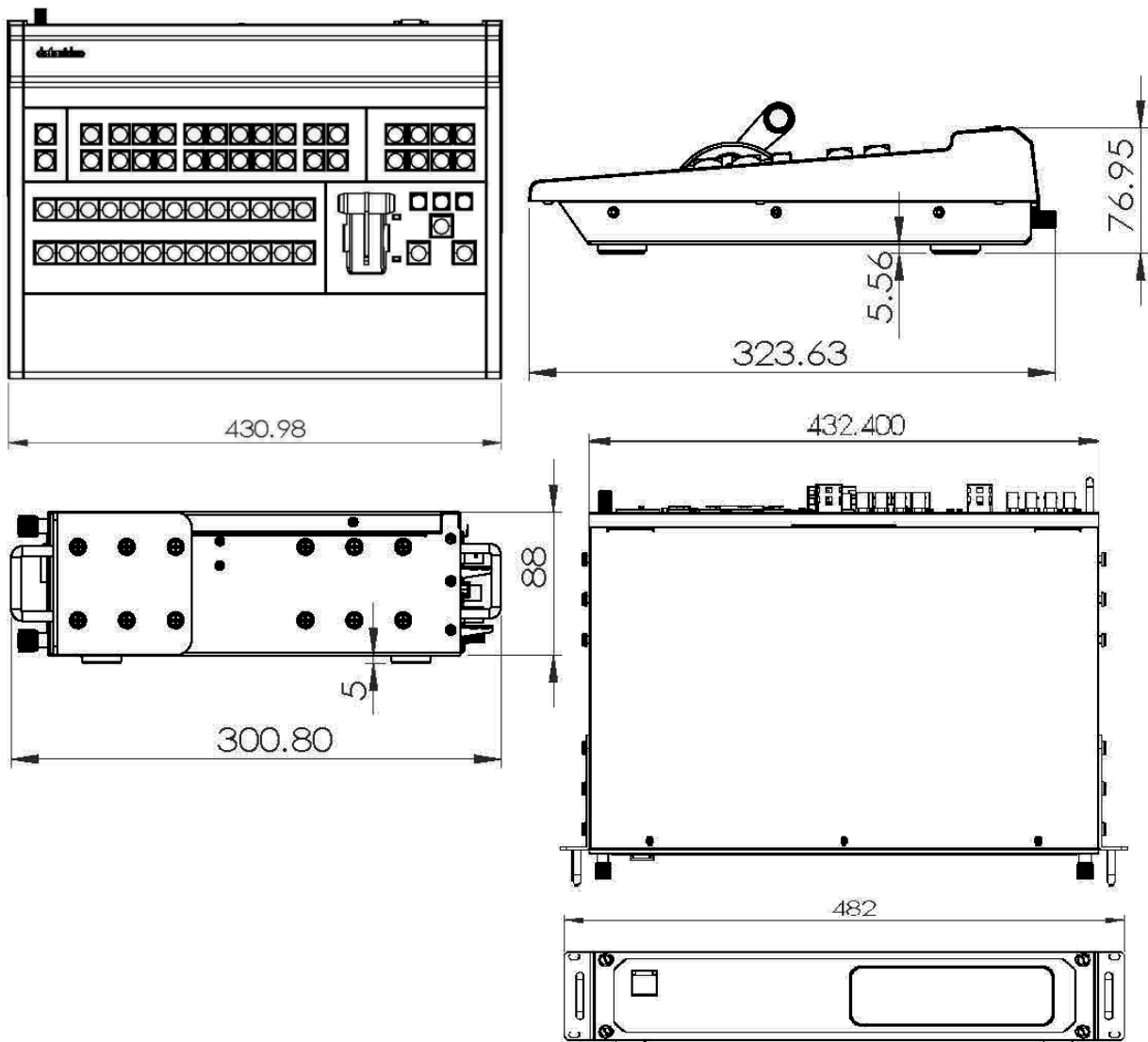

Specification

(Below based on SE-2800 12 channel unit)

Inputs	<ul style="list-style-type: none"> • Maximum 12 inputs, can be configurable to 12 HD SDI, 12 SD SDI, 6 CVBS or 3 HDMI • Possible combination, for example 10 HD SDI + 2 HDMI, or 3 HD SDI + 3 HDMI + 6 CVBS
Outputs	<ul style="list-style-type: none"> • 3 BNC output connectors for SDI Outputs • 2 HDMI for Multiscreen • RJ-45 for PC Remote controls • 2 BNC for Sync-In and Sync-Out • DB-9 for Console
Video Input	<ul style="list-style-type: none"> • HD/SDI: 1920 x 1080i/50, 1920 x 1080i/60 • SD: PAL 720 x 576 /50Hz • SD: NTSC 720 x 480 /59.9Hz • SD: NTSC 7.5 IRE (US standard)/ 0 IRE (Japan standard) options • HDMI 1920 x 1080i/50 • HDMI 1920x1080i/60Hz • HDMI 720 x 576 /50Hz • HDMI 720x480i/60Hz • Y:Cb:Cr, 4:2:2 10 bit
Preview Outputs	<ul style="list-style-type: none"> • 2x HDMI output • Way 1: HDMI 1 Multiscreen1: 9 smaller windows for inputs 1-9 with embedded audio level indication (group1, channel 1) HDMI 2 Multiscreen2: 3 smaller windows for inputs 10-12 with embedded audio level indication (group1, channel 1) + 2 bigger windows for Preview + Program, embedded audio level indication for Program (group1, channel 1) • Way 2: HDMI 1 Multiscreen1- 12 smaller windows for inputs 1-12 with embedded audio level indication (group1, channel 1) + 2 bigger windows for Preview and Program. embedded audio level indication for Program (group1, channel 1) HDMI 2 Multiscreen2 : Program, Multiscreen 1 • Way 3: HDMI 1 Multiscreen1- 8 smaller windows for inputs 1-8 with embedded audio level indication (group1, channel 1) + 2 bigger windows for Preview and Program. embedded audio level indication for Program (group1, channel 1) HDMI 2 Multiscreen 2 : Program, Multiscreen 1 • Resolution is 1920x1080i
Other Interface	<ul style="list-style-type: none"> • Serial D-Sub 9 Pin x 1 RS232 • Tally Output D-Sub 25 Pin x 12 Channel Open Collector Output • Support Line and MIC mode • GPI port
HD SDI signal	<ul style="list-style-type: none"> • SMPTE 292M standard complied with • Output return loss : More than 15 dB (5MHz to 750MHz) More than 10 dB (750MHz to 1.5 GHz) • Output level : 0.8 Vpp ± 10% • Rise time : Less than 270 ps • Fall time : Less than 270 ps • Difference between rise time and fall time within 100 ps • Alignment jitter : Less than 0.2 UI • Timing jitter : Less than 1.0 UI • Eye aperture ratio : More than 90% • DC offset : 0 ± 0.5V • Equalizer use 5C-FB cable support 100 meters
SD SDI signal	Analog Y/C, Composite CCIR601 NTSC and PAL
Operating Temperature	• 0°C to 40°C (32°F to 102°F)
Humidity	• 10% to 90% (non condensing)
Dimension & Weight	Base Unit : 482mm (W) x 88mm (H) x 302mm (D) = 9 Kg Control Panel : 699.4mm (W) x 143.89mm (H) x 436.6mm (D) = 10 Kg
Power	• Input AC 100 ~ 240V Switching Adaptor, output DC 12V / 5A (48W)

Service and Support

It is our goal to make your products ownership a satisfying experience. Our support staff are available to assist you in setting up and operating your system. Please refer to our web site www.datavideo-tek.com for answers to common questions, support requests or contact your local office below.

Datavideo Global Website: www.datavideo-tek.com

Datavideo Corporation

Tel: +1 562 696 2324	Fax: +1 562-698-6930	E-Mail: contactus@datavideo.us
----------------------	----------------------	--

Datavideo Technologies Europe BV

Tel: +31-30-261-96-56	Fax: +31-30 261-96-57	E-Mail: service@datavideo.nl
-----------------------	-----------------------	--

Datavideo UK Limited

Tel: +44 1457 851 000	Fax: +44 1457 850 964	E-Mail: sales@datavideo.co.uk
-----------------------	-----------------------	--

Datavideo Technologies Co., Ltd

Tel: +886 2 8227 2888	Fax: +886-2-8227-2777	E-mail: service@datavideo.com.tw
-----------------------	-----------------------	--

Datavideo Technologies China Co., Ltd

Tel: +86 21-5603 6599	Fax: +86 21-5603 6770	E-mail: service@datavideo.cn
-----------------------	-----------------------	--

Datavideo Technologies (S) PTE Ltd

Tel: +65-6749 6866	Fax: +65-6749 3266	E-mail: sales@datavideo.sg
--------------------	--------------------	--

Datavideo HK Ltd

Tel: +852 2833 1981	Fax: +852-2833-9916	E-mail: info@datavideo.com.hk
---------------------	---------------------	--

Datavideo France s.a.r.l.

Tel: +33 1 60 37 02 46	Fax: +33 1 60 37 67 32	E-mail: info@datavideo.fr
------------------------	------------------------	--

Datavideo Technologies India PVT Ltd.

Tel: +91 120 4309120	Fax: +91 120 4309121	E-mail: sales@datavideo.in
----------------------	----------------------	--

All trademarks are the properties of their respective owners.

Datavideo Technologies Co., Ltd. All rights reserved 2012.

Rev Date: 31/10/2012

P/N: G082060591E1