



---

INSTRUCTION BOOK FOR  
Tensioned Cosmopolitan Electrol  
For Sizes Up To 10' x 10'

---

**DA-LITE**<sup>®</sup>

## Important Safety Instructions

When using your video equipment, basic safety precautions should always be followed, including the following:

1. Read and understand all instructions before using.
2. Position the cord so that it will not be tripped over, pulled, or contact hot surfaces.
3. If an extension cord is necessary, a cord with a current rating at least equal to that of the appliance should be used. Cords rated for less amperage than the appliance may overheat.
4. To reduce the risk of electric shock, do not disassemble this appliance. Contact an authorized service dealer when repair work is required. Incorrect reassembly can cause electric shock when the appliance is used subsequently.
5. The use of an accessory attachment not recommended by the manufacturer may cause a risk of fire, electric shock, or injury to persons.

### Save These Instructions

## Installation

There are three methods of mounting to include:

Flush against wall; Suspended from ceiling (use extension brackets); and recessed above ceiling.

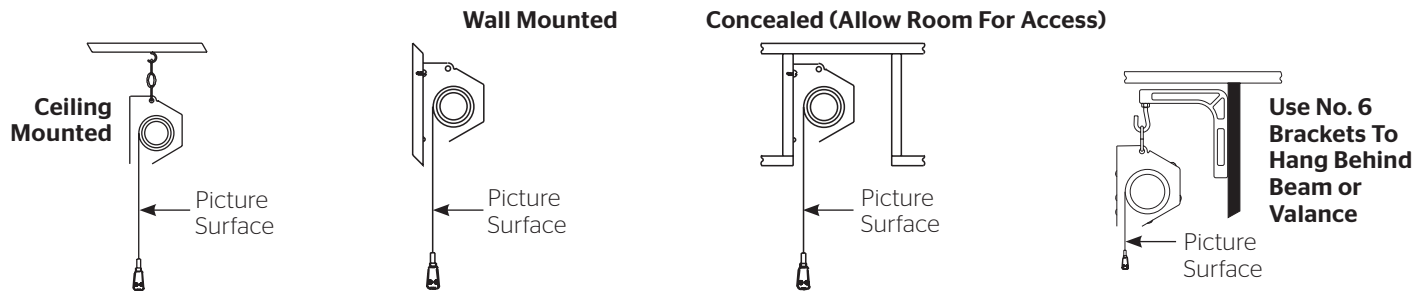

**NOTE:** Under no circumstances should unit be completely sealed in recessed installation. Allow access for service. Picture surface is centered in case. Case extends 5-1/2" beyond surface on either end. Do not attach anything to screen slat rod or bottom fabric pocket.

1. Make sure screen is level. Use a carpenter's level and plumb level.

**⚠ CAUTION! Do not cut wrapping paper or tape with knife or any sharp tool. Remove by hand.**

**⚠ ATTENTION! Ne coupez pas le papier d'emballage ou le ruban adhésif avec un couteau ou un outil tranchant. Retirez à la main.**

2. Install electrical hook-up that applies to your unit. Make sure to review your Electrical Installation Checklists and Wiring Diagrams (included) for either 120 Volt Switch, 220/240 Volt Switch, or Low Voltage Control.

## Pre-Installation

1. Carefully unpack screen and remove outer wrapping from case.
2. Remove shipping brackets by removing the screws from the slat bar and wooden board and use supplied 1/8" next key to remove silver shipping brackets attached to slat.
3. Always handle screen in horizontal position.

3. Test installation by running screen up and down a few times. Be prepared to stop screen. Standard Duty Cycle: 1 MIN. ON / 3 MIN. OFF.

**NOTE:** Must be installed in accordance with the requirements of the Local Building Codes, the Canadian Electrical Code (CEC), CAN/CSA C22.1 and the National Electric Code (NEC), NFPA 70.

# Tensioned Cosmopolitan® Electrol® Installation

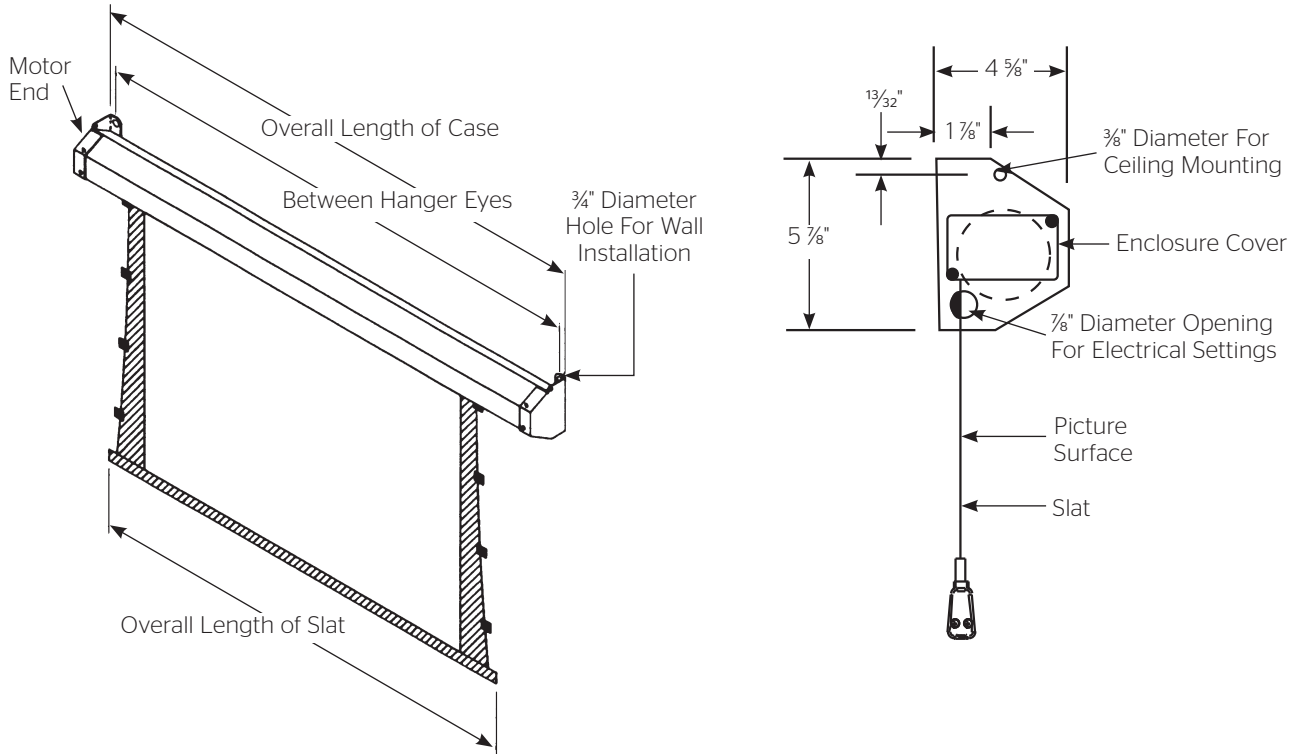

## 120V Wiring Diagram

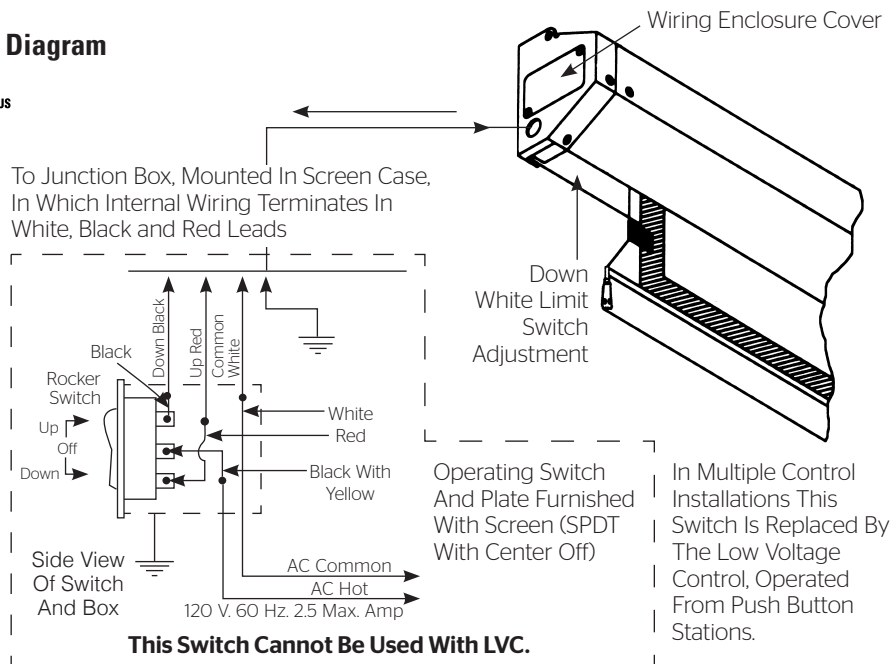

**NOTE:** A single switch cannot be used to operate more than one screen. Contact the factory for further information.

## 240 VOLT WIRING DIAGRAM FOR STANDARD WALL SWITCH:

Da-Lite offers two styles of 240 volt wall switches for standard operation. Please see wiring diagram included in wall switch box included with screen.

# 120V Wiring Diagram with Optional Built-In Low Voltage Control

3-conductor 20-24 gauge wire can be used in place of the supplied RJ-14 cable to connect the wall switch. Connect the BUS terminals on the wall switch to the corresponding BUS terminals on the splitter board.

**IMPORTANT NOTE:** The wall switch is REQUIRED to make any limit switch adjustments, EVEN if a third party control system is used. Therefore, it is advised to wire the switch or provide a 3-conductor connection that is accessible.

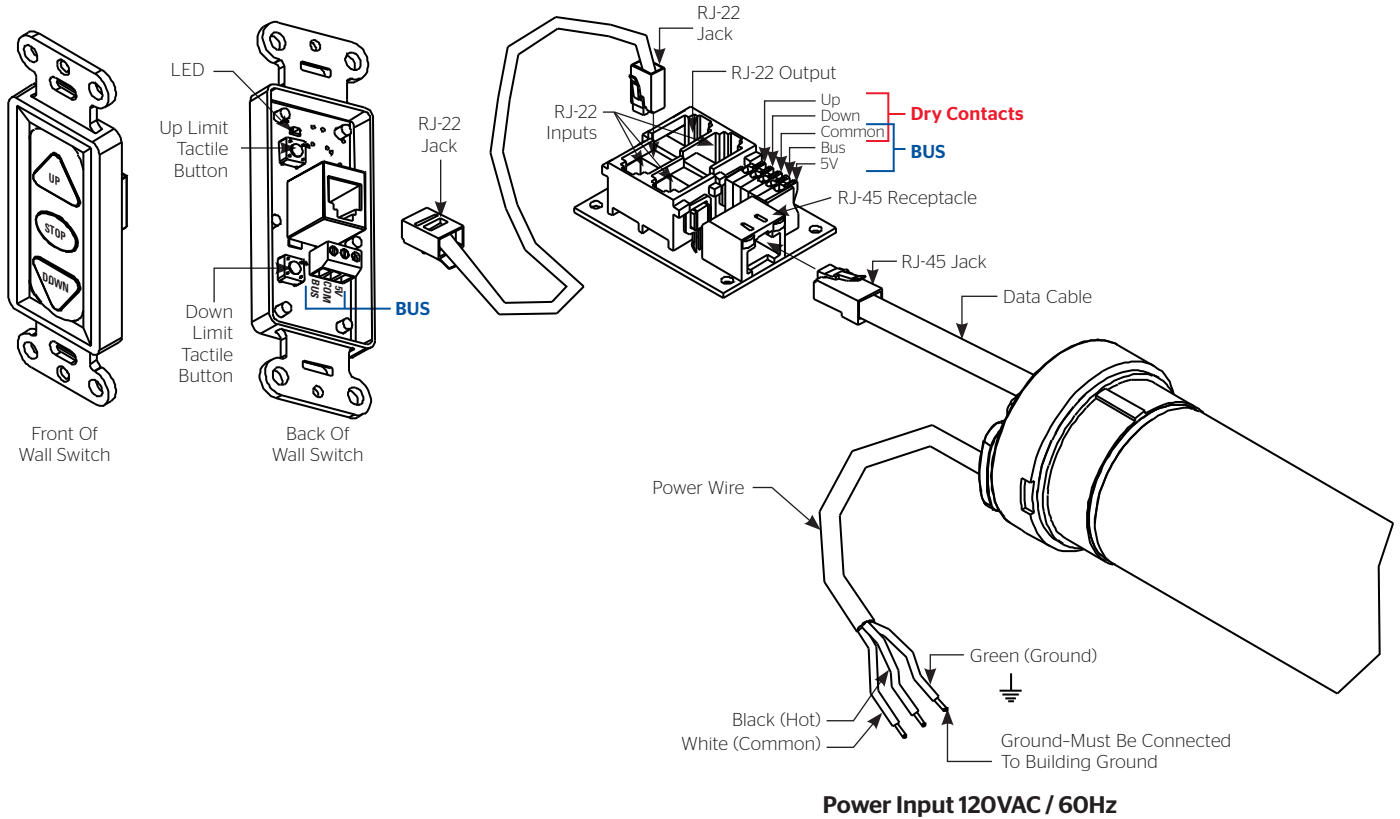

**RJ-14 Pin-Outs (Tab Is Facing Up)**

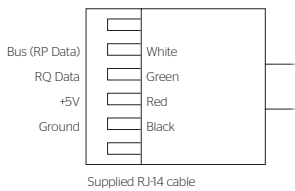

**RJ-22 Pin-Outs (Tab Is Facing Up)**

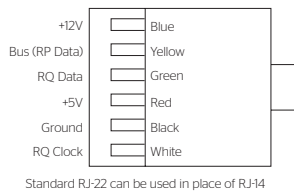

**RJ-45 Pin-Outs (Tab Is Facing Up)**

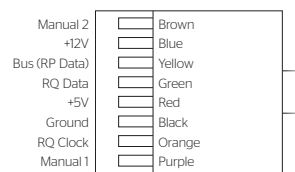

# 120V Wiring Diagram with Optional Built-In Video Projector Interface

**⚠ CAUTION:** The projector must be turned off before connecting the trigger wires to the projector. Failure to do so may damage the controller.

**⚠ ATTENTION:** Le projecteur doit être éteint avant de brancher les fils de déclenchement à celui-ci. Tout manquement à cette instruction pourrait endommager le contrôleur.

Use 2-conductor 20-24 gauge wire to extend the low voltage connection from the projector's 5 or 12-volt screen trigger output to the length required to reach the VPI. When extending the low voltage connection from the projector's screen trigger output polarity does not matter. The red and black wires from the VPI are interchangeable.

**IMPORTANT NOTE:** The wall switch is REQUIRED to make any limit switch adjustments, EVEN if a third party control system is used. Therefore, it is advised to wire the switch or provide a 3-conductor connection that is accessible.

3-conductor 20-24 gauge wire can be used in place of the supplied RJ-14 cable to connect the wall switch. Connect the BUS terminals on the wall switch to the corresponding BUS terminals on the splitter board.

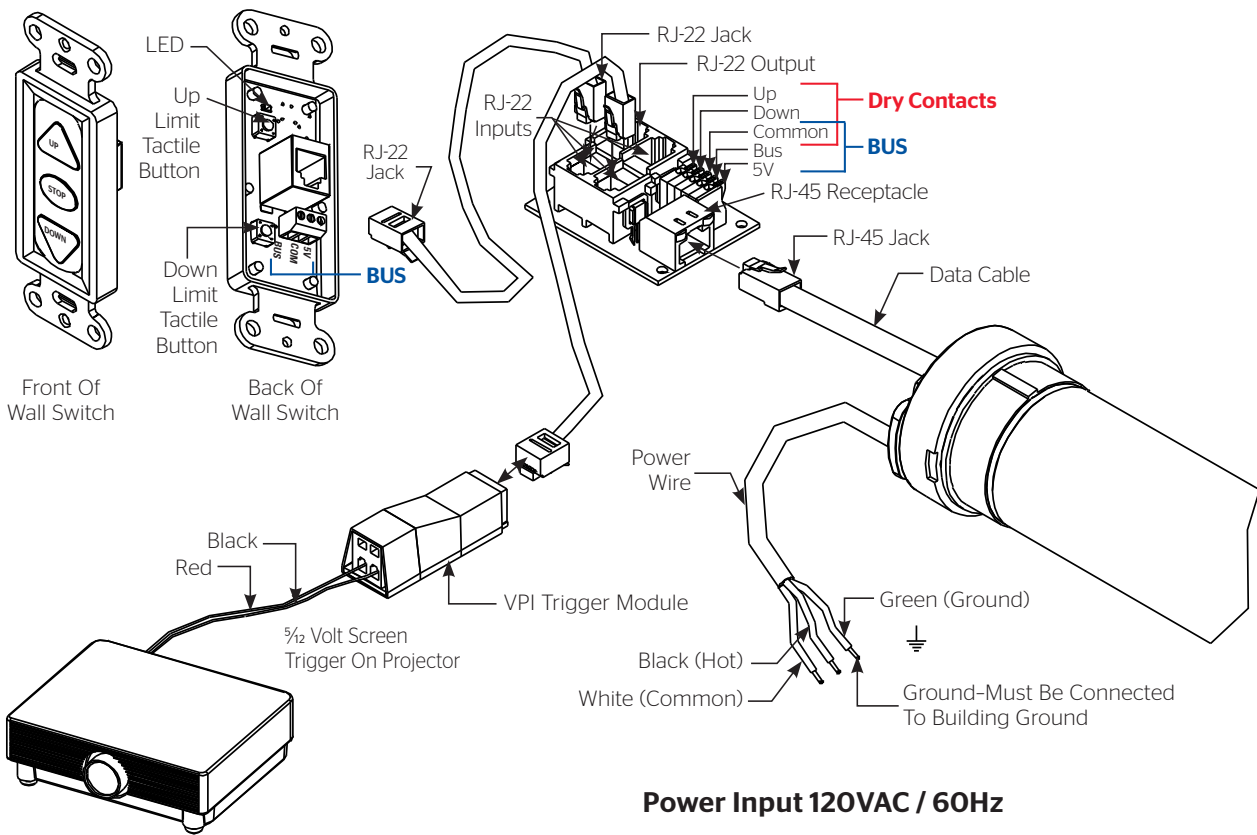

# Tensioned Cosmopolitan® Electrol® Installation

## 240V Wiring Diagram With Optional Built-In Low Voltage Control

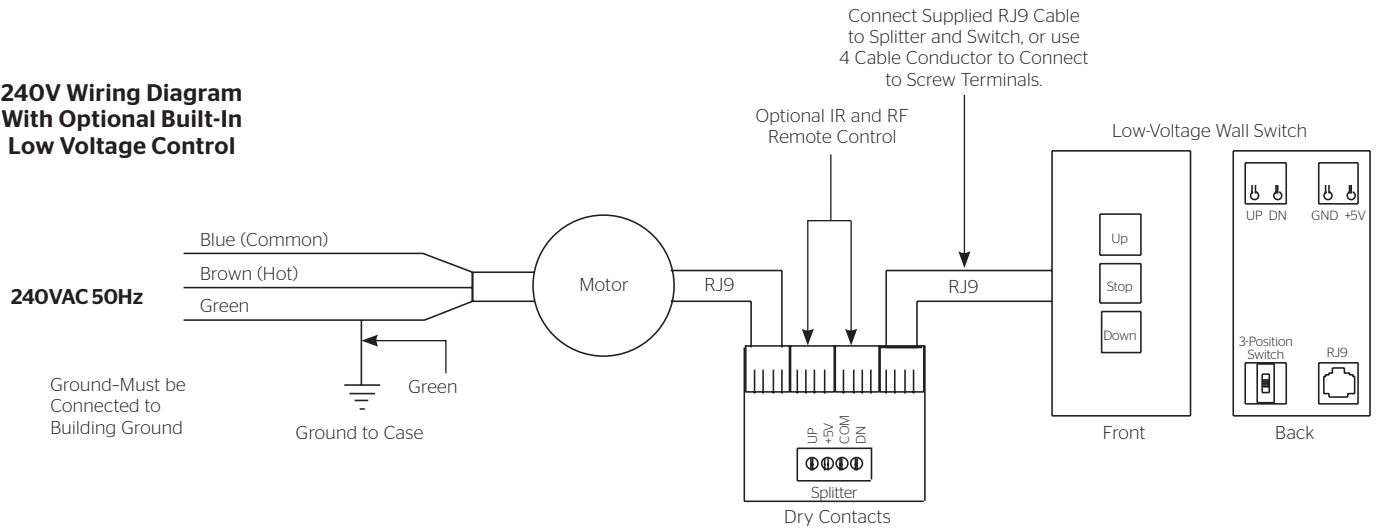

### ILT RJ9 Pin-Outs (Tab Is Facing Up)

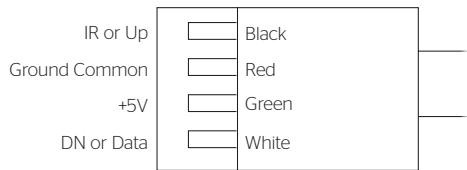

**IMPORTANT NOTE:** The wall switch is REQUIRED to make any limit switch adjustments, EVEN if a third party control system is used. Therefore, it is advised to wire the switch or provide a 4-conductor connection that is accessible.

## Screen Adjustment

The screen surface travel is stopped automatically in the fully opened and closed positions by limit switches that are properly adjusted at Da-Lite. The screen should not be adjusted for more or less drop. The fabric cables are adjusted for proper vertical and lateral tension at Da-Lite.

**⚠ CAUTION!** Contact Da-Lite at 800-622-3737 or 574-267-8101 if screen motor needs adjustment.

**⚠ ATTENTION!** Contactez Da-Lite au 800-622-3737 ou au 574-267-8101 au cas le moteur de l'écran a besoin d'être ajusté.

# Troubleshooting

Visit [www.da-lite.com](http://www.da-lite.com) to find installation and troubleshooting tutorials. You will also find a link to Live Chat for interactive support and you can contact us by email at

[info@da-lite.com](mailto:info@da-lite.com) or by phone at (800) 622-3737 or (574) 267-8101 with any troubleshooting questions.

Symptom	Cause	Solution	
Screen will not operate. Motor does not hum.	Incorrect line voltage.	Verify 115-125V (or 220-240V). If insufficient voltage, rewire incoming electric line.	
	Blown fuse.	Replace fuse.	
	Tripped circuit breaker.	Reset circuit breaker.	
	No power to operating switch or junction.		Check above. Tighten all loose wire connections. Correct any improper connections. "Down" Position Check for power across black and white leads. "Up" Position Check for power across red and white leads.
		Power at junction box. Thermal overload tripped.	Let motor cool down for 15 minutes. Try again.
		Broken wire in the "up" or "down" position.	Check for continuity. Cut off old splice and reconnect.
	Motor hums.	Defective motor, limit switch or capacitor.	Replace motor assembly. NOTE: Motor is a sealed assembly.
Temporary binding.		With power "off", turn roller by hand to free binding.	
Capacitor burned out.		Replace motor assembly.	
Incorrect stopping position in downward direction.	"Down" limit switch out of adjustment.	Contact Da-Lite at 800-622-3737 or 574-267-8101.	
Incorrect stopping position in upward direction.	"Up" limit switch out of adjustment.	Contact Da-Lite at 800-622-3737 or 574-267-8101.	
Noise. NOTE: Screen will operate with a low pitched hum.	Gear noise.	Replace motor assembly.	
Coasting.	Defective brake.	Replace motor assembly.	
Roller displaced from mounting bracket.	Pin end slipped out of nylon bearing.	Realign pin end bracket.	

## LIMITED ONE YEAR WARRANTY ON DA-LITE PRESENTATION PRODUCTS

Milestone AV Technologies LLC warrants certain Da-Lite branded products to the original purchaser only, to be free from defects in materials and workmanship for a period of one (1) year from the date of purchase by the original purchaser; provided they are properly operated according to Da-Lite's instructions and are not damaged due to improper handling or treatment after shipment from the factory.

This warranty does not apply to equipment showing evidence of misuse, abuse or accidental damage, or which has been tampered with or repaired by a person other than authorized Da-Lite personnel.

Da-Lite's sole obligation under this warranty shall be to repair or to replace (at Da-Lite's option) the defective part of the merchandise. Returns for service should be made to your Da-Lite dealer. If it is necessary for the dealer to return the screen or part to Da-Lite, transportation expenses to and from Da-Lite are payable by the purchaser and Da-Lite is not responsible for damage in shipment. To protect yourself against damage or loss in transit, insure the product and prepay all transportation expenses.

**TO THE MAXIMUM EXTENT PERMITTED BY APPLICABLE LAW, THIS WARRANTY IS IN LIEU OF ALL OTHER WARRANTIES, EXPRESS OR IMPLIED, INCLUDING WARRANTIES AS TO FITNESS FOR USE AND MERCHANTABILITY.** Any implied warranties of fitness for use, or merchantability, that may be mandated by statute or rule of law are limited to the one (1) year warranty period. This warranty gives you specific legal rights, and you may also have other rights, which vary from state-to-state. **TO THE MAXIMUM EXTENT PERMITTED BY APPLICABLE LAW, NO LIABILITY IS ASSUMED FOR EXPENSES OR DAMAGES RESULTING FROM INTERRUPTION IN OPERATION OF EQUIPMENT, OR FOR INCIDENTAL, DIRECT, OR CONSEQUENTIAL DAMAGES OF ANY NATURE.**

In the event that there is a defect in materials or workmanship of a Da-Lite product, you may contact our Sales Partners at PO Box 137, Warsaw, IN 46581-0137, (574) 267-8101, (800) 622-3737.

**IMPORTANT: THIS WARRANTY SHALL NOT BE VALID AND DA-LITE BRANDED PRODUCTS SHALL NOT BE BOUND BY THIS WARRANTY IF THE PRODUCT IS NOT OPERATED IN ACCORDANCE WITH THE DA-LITE WRITTEN INSTRUCTIONS.**

Keep your sales receipt to prove the date of purchase and your original ownership.



A Milestone AV Technologies Brand

3100 North Detroit Street  
Warsaw, Indiana 46582  
P: 574.267.8101 or 800.622.3737  
F: 574.267.7804 or 877.325.4832  
E: info@da-lite.com  
www.da-lite.com

DL-0264 (Rev. 2) 10.14

© 2014 Milestone AV Technologies LLC. Printed in U.S.A.

76063