

**datavideo<sup>®</sup>**

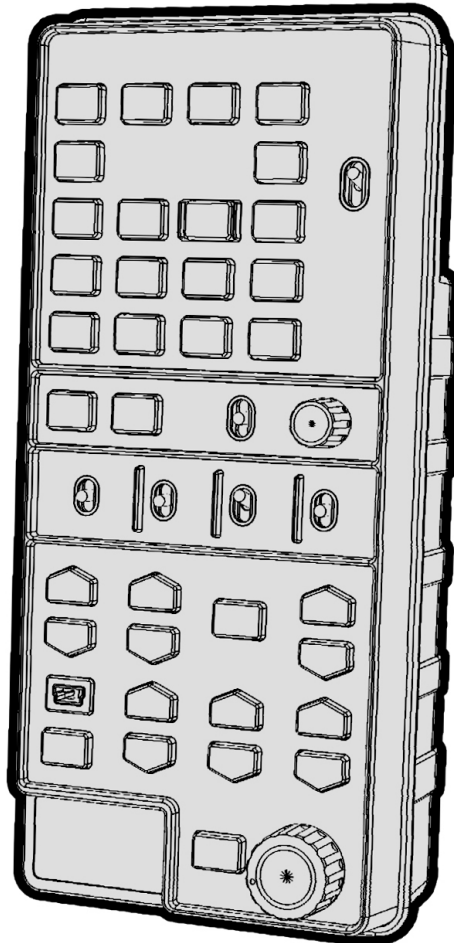

**MULTI-CAMERA  
CONTROL UNIT  
MCU-100**

**Instruction manual**

[www.datavideo.com](http://www.datavideo.com)

## Contents

|   |           |
|---|-----------|
| <b>Warnings and Precautions</b> .....             | <b>3</b>  |
| <b>Warranty</b> .....                             | <b>4</b>  |
| <b>Disposal</b> .....                             | <b>4</b>  |
| <b>Packing List</b> .....                         | <b>5</b>  |
| <b>Introduction</b> .....                         | <b>5</b>  |
| <b>Features</b> .....                             | <b>6</b>  |
| <b>Example MCU-100 Set Up</b> .....               | <b>7</b>  |
| <b>Connections and Controls</b> .....             | <b>8</b>  |
| <b>MCU-100 Keyboard Guide</b> .....               | <b>10</b> |
| <b>How to store selected camera set ups</b> ..... | <b>15</b> |
| <b>Firmware update procedure</b> .....            | <b>17</b> |
| <b>Specifications</b> .....                       | <b>19</b> |
| <b>Service &amp; Support</b> .....                | <b>20</b> |

### Disclaimer of Product and Services

The information offered in this instruction manual is intended as a guide only. At all times, Datavideo Technologies will try to give correct, complete and suitable information. However, Datavideo Technologies cannot exclude that some information in this manual, from time to time, may not be correct or may be incomplete. This manual may contain typing errors, omissions or incorrect information. Datavideo Technologies always recommend that you double check the information in this document for accuracy before making any purchase decision or using the product. Datavideo Technologies is not responsible for any omissions or errors, or for any subsequent loss or damage caused by using the information contained within this manual. Further advice on the content of this manual or on the product can be obtained by contacting your local Datavideo Office or dealer.

## Warnings and Precautions

1. Read all of these warnings and save them for later reference.
2. Follow all warnings and instructions marked on this unit.
3. Unplug this unit from the wall outlet before cleaning. Do not use liquid or aerosol cleaners. Use a damp cloth for cleaning.
4. Do not use this unit in or near water.
5. Do not place this unit on an unstable cart, stand, or table. The unit may fall, causing serious damage.
6. Slots and openings on the cabinet top, back, and bottom are provided for ventilation. To ensure safe and reliable operation of this unit, and to protect it from overheating, do not block or cover these openings. Do not place this unit on a bed, sofa, rug, or similar surface, as the ventilation openings on the bottom of the cabinet will be blocked. This unit should never be placed near or over a heat register or radiator. This unit should not be placed in a built-in installation unless proper ventilation is provided.
7. This product should only be operated from the type of power source indicated on the marking label of the AC adapter. If you are not sure of the type of power available, consult your Datavideo dealer or your local power company.
8. Do not allow anything to rest on the power cord. Do not locate this unit where the power cord will be walked on, rolled over, or otherwise stressed.
9. If an extension cord must be used with this unit, make sure that the total of the ampere ratings on the products plugged into the extension cord do not exceed the extension cord rating.
10. Make sure that the total amperes of all the units that are plugged into a single wall outlet do not exceed 15 amperes.
11. Never push objects of any kind into this unit through the cabinet ventilation slots, as they may touch dangerous voltage points or short out parts that could result in risk of fire or electric shock. Never spill liquid of any kind onto or into this unit.
12. Except as specifically explained elsewhere in this manual, do not attempt to service this product yourself. Opening or removing covers that are marked "Do Not Remove" may expose you to dangerous voltage points or other risks, and will void your warranty. Refer all service issues to qualified service personnel.
13. Unplug this product from the wall outlet and refer to qualified service personnel under the following conditions:
  - a. When the power cord is damaged or frayed;
  - b. When liquid has spilled into the unit;
  - c. When the product has been exposed to rain or water;
  - d. When the product does not operate normally under normal operating conditions. Adjust only those controls that are covered by the operating instructions in this manual; improper adjustment of other controls may result in damage to the unit and may often require extensive work by a qualified technician to restore the unit to normal operation;
  - e. When the product has been dropped or the cabinet has been damaged;
  - f. When the product exhibits a distinct change in performance, indicating a need for service.

## Warranty

### Standard Warranty

- Datavideo equipment is guaranteed against any manufacturing defects for one year from the date of purchase.
- The original purchase invoice or other documentary evidence should be supplied at the time of any request for repair under warranty.
- Damage caused by accident, misuse, unauthorized repairs, sand, grit or water is not covered by this warranty.
- All mail or transportation costs including insurance are at the expense of the owner.
- All other claims of any nature are not covered.
- Cables & batteries are not covered under warranty.
- Warranty only valid within the country or region of purchase.
- Your statutory rights are not affected.



### Two Year Warranty

- All Datavideo products purchased after 01-Oct.-2008 qualify for a free one year extension to the standard Warranty, providing the product is registered with Datavideo within 30 days of purchase. For information on how to register please visit [www.datavideo.com](http://www.datavideo.com) or contact your local Datavideo office or authorized Distributors.
- Certain parts with limited lifetime expectancy such as LCD Panels, DVD Drives, Hard Drives are only covered for the first 10,000 hours, or 1 year (whichever comes first).

Any second year warranty claims must be made to your local Datavideo office or one of its authorized Distributors before the extended warranty expires.

## Disposal



### For EU Customers only - WEEE Marking.

This symbol on the product indicates that it should not be treated as household waste. It must be handed over to an applicable take-back scheme for the recycling of Waste Electrical and Electronic Equipment. For more detailed information about the recycling of this product, please contact your local Datavideo office or your local recycling centre.

## Packing List

The following items should be included in the box. If any items are missing please contact your supplier.

| Item No. | Description         | Quantity |
|----------|---------------------|----------|
| 1        | MCU-100 Control Box | 1        |
| 2        | Accessory kit *     | 1        |
| 3        | Instruction Manual  | 1        |

*\*The accessory kit also contains a packing list.*

## Introduction

The Datavideo MCU-100 Controller can be used to remotely set up, from a gallery or OB Van, Panasonic P2 cameras such as the AG-HPX255, AG-HPX371 or AG-HPX600. The MCU-100 can be connected with up to four Panasonic cameras allowing settings from one camera to be aligned with the other cameras quickly. With features similar to Panasonic's own AG-EC4G Extension Control Unit the MCU-100 reduces cost, manpower, equipment, set up time and saves desk space.

*That's Datavideo; sharing the value!*

To get more value out of this equipment please take a few minutes to read through this manual. This will help you to familiarise yourself with all the aspects of the MCU-100 control unit.

## Features

- Four RJ-45 connections allow remote set up of up-to four Panasonic cameras.
- RJ-45 cabling allows unit to be placed up to 300m away from the camera(s).
- Control of Record and Playback functions.
- Control of Camera User memory functions.
- Control of Camera OSD Menu Navigation.
- Control of Shutter speed and degree functions.
- Control of Iris adjustment.
- Control of AWB & ABB functions.
- Control of White Balance A, B and Preset functions.
- Control of Camera Knee & Bars functions.
- Control of Camera Gain adjustment.
- RGB / R & B gain and Master Pedestal controls.

## Compatible Camera Models

AG-HPX255, AG-HPX370, AG-HPX371, AG-HPX372, AG-HPX600, AJ-HPX2700G, and AJ-HPX3000

**\*Note:** Datavideo have tested and found the above Panasonic cameras to be compatible with the MCU-100 unit. However, due to the differences between individual Panasonic camera models some features or settings may be limited. In most cases the same limitation also applies to the Panasonic AG-EC4G unit.

# Example MCU-100 Set Up

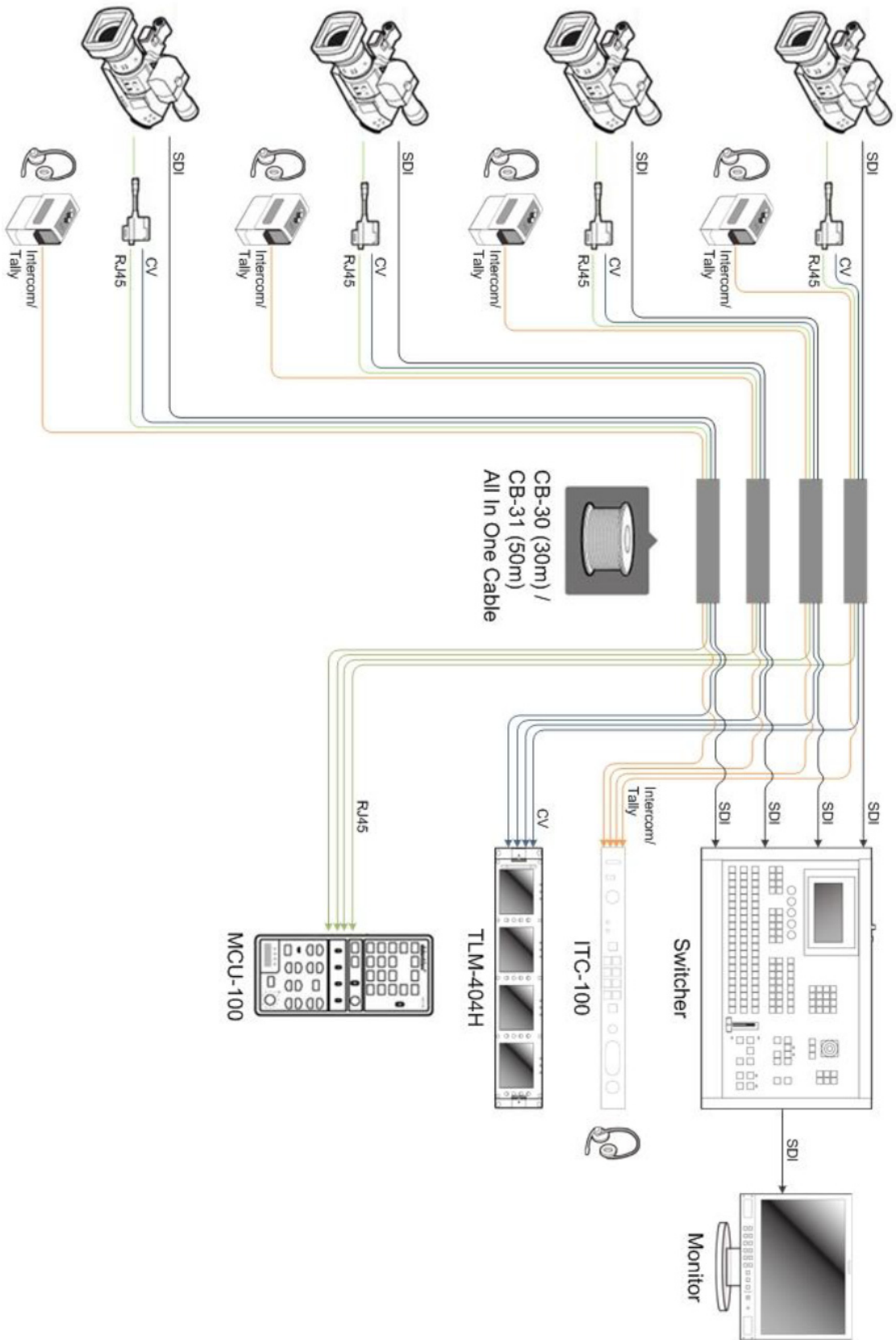

# Connections and Controls

## MCU-100 Keyboard

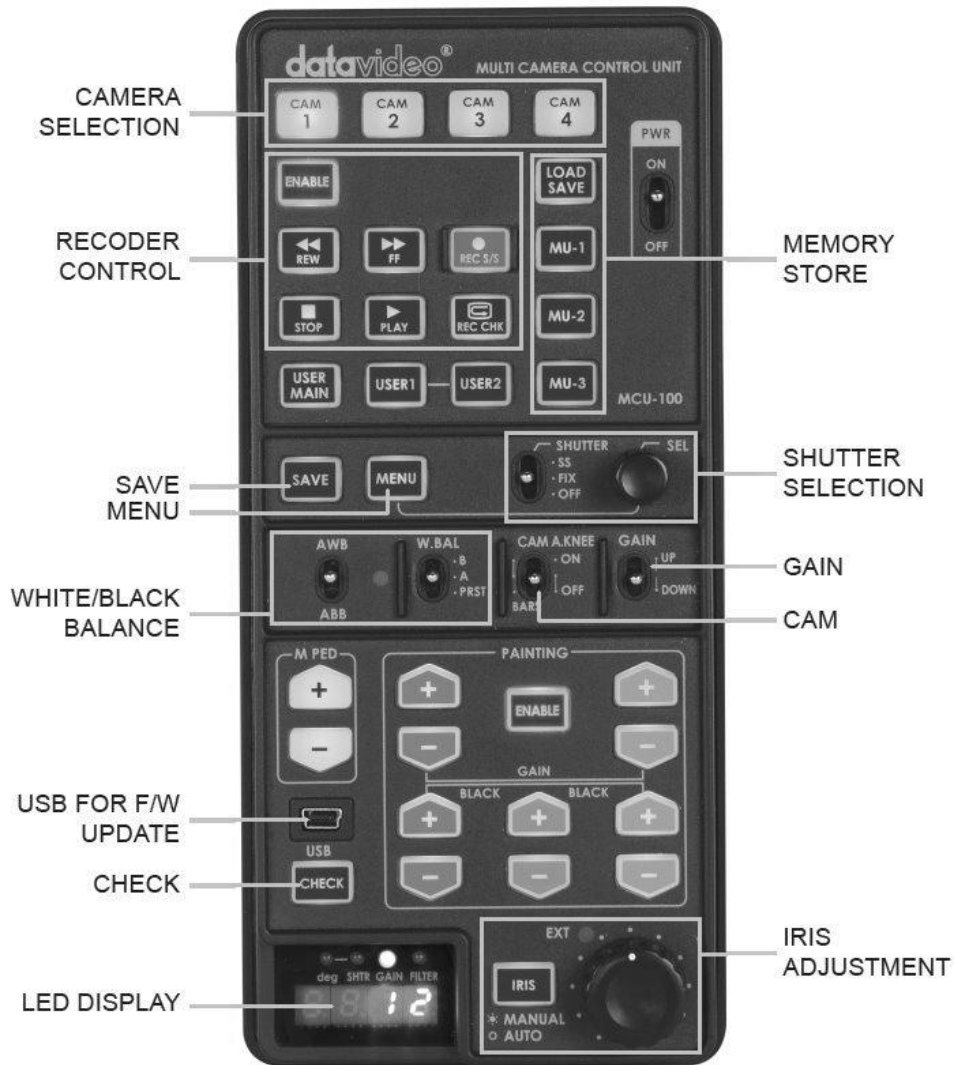

## MCU-100 Front Panel

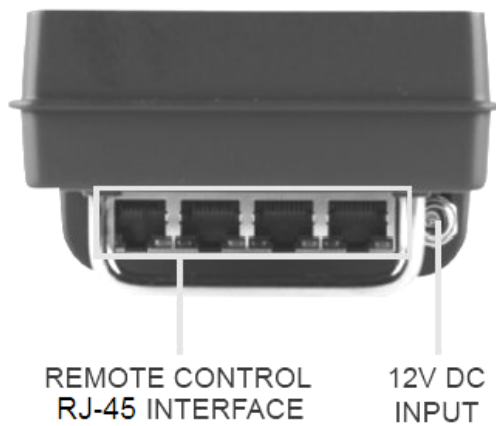



## AD-1 Camera Control Adaptor



This unit allows you to operate the functions of the camera up to 300m away with the MCU-100 unit.

The AD-1 adaptor connects to the MCU-100 via RJ-45 cabling to the chosen Panasonic camera. This adaptor changes the RJ-45 connection to a Panasonic CAM/BS cable and multi-pin connector.

**NOTE:** Be very careful with the Panasonic CAM/BS cable connector which plugs into the remote socket of the Panasonic camera. This connector only slides into the camera's remote socket when the notches and pins are matched up correctly. ***Do not twist or force this connection as damage to the camera or connector pins may happen.***

**NOTE:** With the AD-1 connected, the menu and other functions of the Panasonic camera may be limited to remote control only. To regain manual control of the menu functions on the camera first disconnect the AD-1.

The AD-1 also features a BNC type Composite (CV) output which can be taken to an SD monitor on or near the camera. This Composite output can be used for confidence and composition monitoring and in some cases to view the camera's own LCD/OSD menus too. ***Please note this feature is camera model and firmware dependant.***

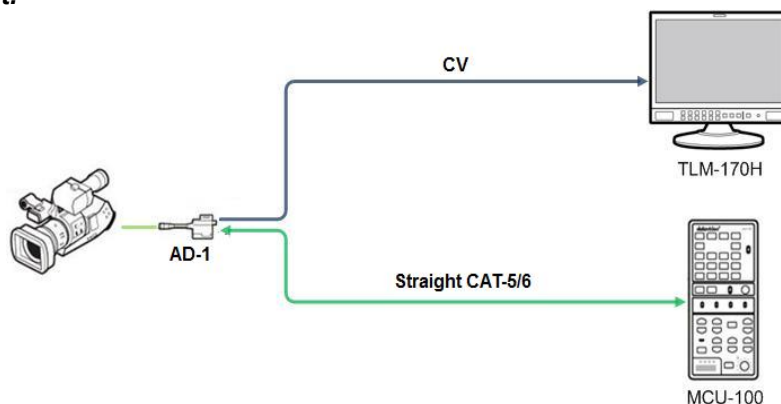

Each AD-1 adaptor has a built in velcro strap so that the unit can be quickly mounted in a convenient location on or near the camera.

A micro USB 2.0 port is provided for transfer of firmware updates to the unit. See [page 17](#) for more details.

# MCU-100 Keyboard Guide



## Power switch

Use this switch to power the MCU-100 On or Off.



## Camera selection

Select the button for the camera that you wish to control.



## MCU-100 Memory stores

Using the LOAD SAVE button it is possible to transfer the current setting from one camera to another.

MU-1, MU-2 and MU-3 can be used to store settings within the MCU-100.

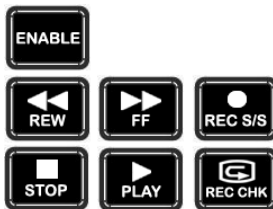

## Recorder / Playback functions

ENABLE when selected activates the recorder / playback functions of the chosen camera. This includes rewind [REW], fast forward [FF], record start/stop [REC S/S], stop, play and record check [REC CHK].

REC CHK makes it possible to check what has just been recorded (2 seconds REC review) by pressing this button during REC pause.

With a DVCPRO HD camera recorder, the tape is cued to provide continuity from one shot to the next when this button is pressed while playback is paused.



## User defined functions from the Camera

These buttons match the user defined functions of the USER MAIN, USER1 and USER2 buttons on the chosen camera. Operation will follow the function that was assigned by the user in the chosen cameras OSD menu. **NOTE:** USER 2 button will work as a thumbnail ON switch for the AG-HP255 and AG-HPX371. MENU button is back lit orange at this time.



## Data save – save defined functions from the camera

When this function is enabled, the button is back lit orange and the MCU-100 settings are stored into the chosen camera.

If this function is disabled - the button is back lit green; any chosen MCU-100 settings will not be stored in the chosen camera. The current camera/MCU-100 settings will be reset to defaults when the power of the unit or the camera is turned off.



### Menu

When this function is enabled, the button is back lit orange and the OSD menu is shown on the LCD panel/view finder of the camera. This OSD menu may also be shown on the AD-1's composite output (if supported).

Some camera models also allow this OSD menu to be displayed on the SDI or HDMI output of the chosen camera. Refer to your cameras manual for more details on its OSD Menu outputs and change settings where necessary.



### Shutter switch

To change operation of the shutter.

**OFF** : To turn off the shutter operation.

**FIX** : To turn on fixed shutter mode.

**SS** : To turn on synchro scan mode.



### SEL - Select dial

The select dial is used for two functions, to navigate the menus or to control the shutter speed.

When the MENU button is active and back lit orange. The select dial is turned to navigate through the camera's menu options. Pressing in the same dial, like a button, confirms the current selection or value shown.

When the MENU button is NOT active and back lit green. The select dial can be turned to adjust the SHUTTER speed of the camera.

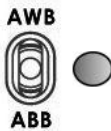

### AWB / ABB switch with LED

This switch is used to trigger Auto White Balance (AWB) or Auto Black Balance (ABB) adjustment.

**AWB**: White balance is adjusted automatically. When the W.BAL switch is set to A or B at this time, the value to which the balance was adjusted will be stored in memory A or memory B.

**ABB**: Black balance is adjusted automatically. This value will be stored in a dedicated ABB memory.

**LED ON**: Auto white balance / auto black balance in progress.

**LED OFF**: Auto white balance / auto black balance completed.

**LED stops blinking and goes off**: Auto white balance / auto black balance error.



### W.BAL switch

This switch is used to recall the preset or stored values of white balance in the camera.

**A or B**: This will apply the value stored in the white balance A or B memory in the camera recorder. When the AWB / ABB switch is set to the AWB position, the white balance is automatically adjusted and the value adjusted is stored in the selected memory A or B.

**PRST**: This will apply the preset value of the white balance stored in the camera recorder.



**CAM A.KNEE switch**

To select the video signals to be output from the camera.

**BARS:** Camera generated colour bar signals are output.

**CAM. AUTO KNEE OFF:** The images shot by camera are output. The AUTO KNEE circuit does not work. MANUAL KNEE is set as the camera recorder's initial setting.

**CAM. AUTO KNEE ON:** The images shot by the camera are output. The AUTO KNEE circuit works.

**NOTE:** AUTO KNEE circuit will not be effective if DRS (Dynamic Range Stretch) function is enabled. It is also possible to allocate the MANUAL KNEE and DRS functions via the menu settings on the camera.



**GAIN switch**

Allows selection of the video amplifier's gain depending on the lighting conditions that are present in the camera's location.

Moving the switch upwards increases the gain in dB steps. Moving the switch downwards decreases the gain in dB steps.



**Master Pedestal Control**

These buttons are used to adjust the level of the Master Pedestal.

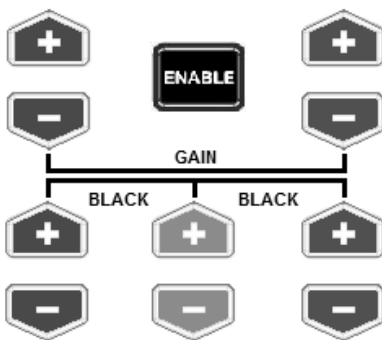

**Enable & Painting Adjustment buttons**

Press the ENABLE button in the *Painting area* of the MCU-100 before choosing to adjust either the level of the Red and Blue Gain or the RGB Pedestal values.



**Mini B USB 2.0 port**

This port is used for firmware updates or to save/transfer MCU-100 settings to computer.

See **page 17** for firmware update details.

See **page 16** for saving/transferring settings with a computer.



### **CHECK / Lock**

GAIN value, SHUTTER speed, FILTER position, IRIS, Master Pedestal, R/B Gain and RGB pedestal values are shown on the display below in this order each time the CHECK button is pressed.

If the CHECK button is pressed and held down for over two seconds the MCU-100 unit will switch in to LOCK mode.



### **LED display**

The IRIS value, Shutter degree, speed, Gain and Filter positions can be displayed here by using the CHECK button.

\*The M. PED, PAINTING GAIN R/B and BLACK R/G/B values can also be displayed sequentially here. See CHECK button also.

When in LOCK mode this display will show Lock.



### **EXT LED**

This LED will be ON when a lens extender is detected on the chosen camera.



### **IRIS control**

Used to adjust the Iris value. See IRIS and CHECK buttons also.



### **IRIS button**

To enable or disable Auto Iris.

The button is back lit orange when Auto Iris is enabled.

## Seven segment display and LEDs



**LED** Indicates the displayed format of SHUTTER value.

**Deg** **LED ON** : Shutter angle is displayed.  
**LED OFF**: Shutter speed is displayed.

**SHTR** When LED ON displays SHUTTER (speed) value.

**GAIN** When LED ON displays GAIN value (in dB).

**FILTER** When LED ON displays ND FILTER mode (F1~F5).

## Operation Modes – LOCK and NORMAL

There are two modes of operation on the MCU-100.

1. **NORMAL**: This is always active when the unit is first turned on. Under this mode all functions are available. Buttons not back lit indicate functions that are currently not in use. The user may activate these functions via an associated ENABLE button.
2. **LOCK**: This mode is activated by pressing and holding down the CHECK button for two seconds. When in LOCK mode all functions are unavailable except for the 4 Camera selection buttons and the CHECK function. This is to prevent unauthorized or unintended operation during a LIVE production. The seven segment LED display will also show Lock.

Iris controls can be quickly accessed in LOCK mode by pressing down on the IRIS Dial once; press the dial again to return to full lock mode. When the Iris function is accessed in this way, if the MCU-100 unit is left idle for 3 seconds or more then the unit will automatically return to full Lock mode.

The Lock mode can be deactivated by pressing and holding down the CHECK button for two seconds.

## How to store selected camera set ups

### How to copy settings set by MCU-100 from one camera to another

When MCU-100 is used to control more than one camera, it is possible to copy the settings set by the unit on one camera to another via the Memory Stores functions of the unit.

Follow the following procedure to copy the settings set by the unit on camera to another.

1. Select the camera from which you want to copy the settings via the CAM 1 to CAM 4 buttons.
2. Press the LOAD SAVE button to start the copy process. The LOAD SAVE button will be back lit orange and blinking.
3. Whilst the LOAD SAVE button is back lit orange and blinking select the camera to which you want to copy the settings via the CAM 1 to CAM 4 buttons.
4. When the LOAD SAVE button is back lit green the copy process is then completed.

**Note:** This process does not work if either the selected source or destination camera is not connected or is not powered on.

### How to store / recall settings from internal memory MU-1, MU-2 or MU-3

The MCU-100 has dedicated internal memory to store the settings set by the unit on four cameras. This internal memory can be accessed using the Memory Store functions.

Internally, the unit has three memory blocks indicated by the Memory Stores MU-1, MU-2 and MU-3. Each of these blocks is divided into four segments, one segment for each camera. These are used to store the settings for each camera accordingly.

Use this procedure **to store** the settings on a camera to the MCU-100 unit's internal memory.

1. Select the camera from which you want to copy the settings via the CAM 1 to CAM 4 buttons.
2. Press the LOAD SAVE button to start the copy process. The LOAD SAVE and the selected camera button will be back lit orange and blinking.
3. Whilst these buttons are back lit orange and blinking select the memory block, MU-1, MU-2 or MU-3 button, to which you want to copy the settings.
4. When the MU-1, MU-2 or MU-3 button is back lit green and the copy process is then completed.

Use this procedure **to recall** a previously saved setting on the MU-1, MU-2 or MU-3 button to a camera.

1. Select the camera to which you want to copy the stored settings via the CAM 1 to CAM 4 buttons.
2. Select the memory block from which you want to copy the settings via the MU-1, MU-2 or MU-3 button.
3. Press the LOAD SAVE button to start the copy process. The LOAD SAVE and the selected camera button will be back lit orange and blinking.
4. These buttons will be back lit green when copy process is completed.

## How to save / load the camcorders' settings to / from a PC

It is possible to save the current settings on all four cameras from MCU-100 to a PC for later use. Also any previously saved MCU-100 settings stored on a PC can also be loaded back to the MCU-100 unit. This can be handy if multiple users have access to the equipment and you need a quick way to get back to your preferred settings.

Use the following procedure to save the current camera settings set by the MCU-100 unit to a PC.

1. Power off the MCU-100 unit.
2. Connect the MCU-100 unit to PC using USB cable via the USB 2.0 (Mini B) interface.

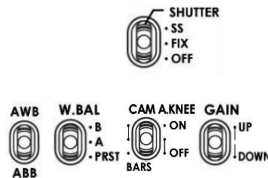

3. Set the five switches  on the MCU-100 unit to their middle position.
4. Press and hold in both the CAM 1 & MU-1 buttons at same time and then power on the MCU-100 unit.
5. The seven segment LED Display will show “cU--”, and the PC will detect the MCU-100 unit as an external storage device named “MCU-100\_MUx”.
6. Open the “MCU-100\_MUx” folder on the PC and copy “mu\_param.bin” file to desired PC hard drive location.
7. Once complete unplug the USB cable and reboot the the MCU-100 unit.

To load previously saved settings on a PC to MCU-100.

**Repeat steps** 1~5 of the above procedure and then continue with the following steps.

6. Open the “MCU-100\_MUx” file folder on PC and delete the “mu\_param.bin” file.
7. Copy the previously saved “mu\_param.bin” file from the PC hard drive location to the “MCU-100\_MUx” folder.

**Note:** Do not worry if the previously saved xxxxxxxx.bin file has been renamed on the PC. The MCU-100 unit will automatically amend the file name back to “mu\_param.bin” after a reboot.

8. Once the copy process is complete unplug the USB cable and reboot the MCU-100 unit.



## Firmware update procedure

From time to time Datavideo may release new firmware to either add new features or to fix reported bugs in the current MCU-100 firmware. Customers can update the firmware themselves if they wish or they can contact their local dealer or reseller for assistance should they prefer this method.

This page describes the firmware update process and it should take **approximately 20 minutes total time to complete**.

Once started **the update process should not be interrupted in any way** as this could result in a non-responsive unit.

**As well as a working MCU-100 you will need:**

➤ The latest firmware update for the **AD-1** units **and** the **MCU-100**.

➤ The **NuMicro ISP Programming Tool** software.

The above items can be obtained from your local Datavideo office.

➤ USB 2.0 cable with a USB A type connector and Micro USB connector.

➤ A Windows Vista or 7 computers with USB 2.0 port.

**Note:** It is best to update the firmware of the **AD-1** unit(s) at the same time as the **MCU-100**.

## How to update the MCU-100 firmware

1. Turn off the MCU-100 power.
2. USB cable connects the MCU-100 to PC.

3. Set the five switches  on the MCU-100 to their middle position.

4. Move  switch up towards (**AWB**) and at the same time also press the **shutter select** button in. Hold both in place.
5. Turn on the MCU-100 power.
6. MCU-100 LED display will show “L-x.x”, and the PC will find MCU-100 by USB 2.0.
7. Open “**MCU-100\_U1**” folder on PC.
8. Delete the **bootcode.bin** file in “**MCU-100\_U1**” folder.
9. Copy new **xxxxxxxxx.bin** file to the “**MCU-100\_U1**” folder. Do not worry about the new file name; the MCU-100 will amend the file name automatically after reboot.
10. Reboot MCU-100.

**Note:** It is best to update the firmware of the **AD-1** unit(s) at the same time as the **MCU-100**.

## How to update the AD-1 firmware with the NuMicro ISP Programming Tool

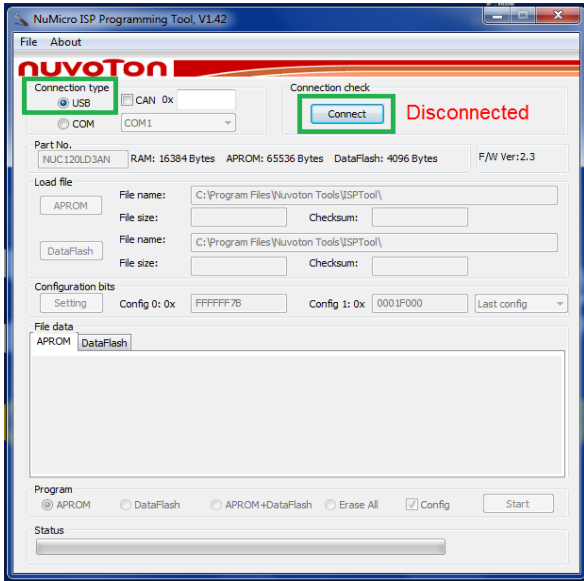

Install the software tool by using the “Setup, NuMicro ISP Programming Tool, v1.42” on your Windows 7 PC.

Connect the USB cable to the AD-1 Micro USB port and then to your PC.

Use the desktop Icon to launch the software tool.

Select “**Connect**”

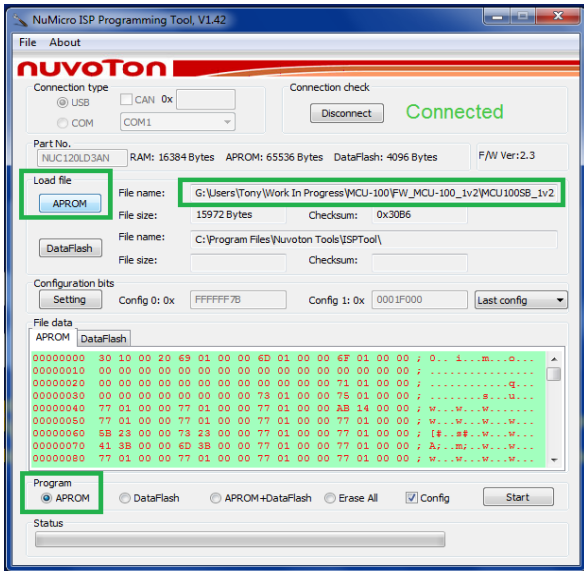

Click on the **Load File “APROM”** button and then browse to the location of the Firmware bin file.

Click on the **Program “APROM”** radio button, and then click on the “**Start**” button to begin the update process.

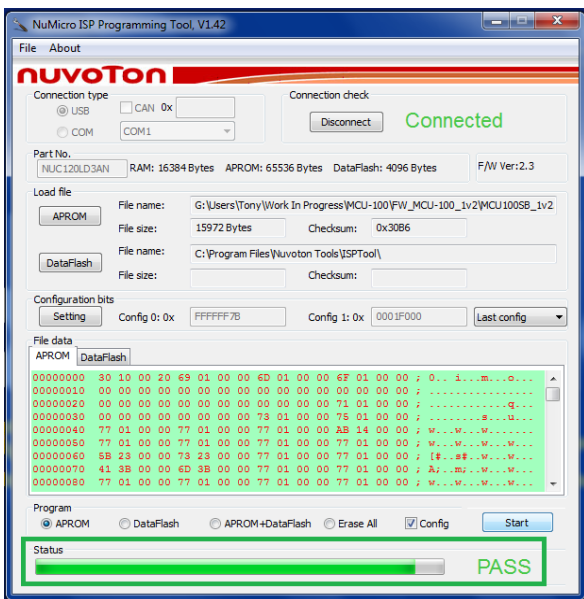

A firmware update progress bar will be shown at the bottom of the window.

Once finished the program will show **PASS** and then disconnect the AD-1.

Remove the USB Cable and then connect the AD-1 to the camera’s remote port to test the new firmware.

**Note:** It is best to update the firmware of the **AD-1** unit(s) at the same time as the **MCU-100**.

## Specifications

|                                 |                                 |
|---------------------------------|---------------------------------|
| <b>Power Consumption</b>        | DC 12V / 0.5A ( 6W )            |
| <b>Weight</b>                   | 350 g                           |
| <b>Dimension</b>                | 95mm (W) x 208mm (H) x 54mm (D) |
| <b>Input /Output Connection</b> | RJ45 x 4                        |
| <b>Connection Distance</b>      | Up to 300m (CAT-5 or CAT6)      |

# Service & Support

It is our goal to make your products ownership a satisfying experience. Our supporting staff is available to assist you in setting up and operating your system. Please refer to our web site [www.datavideo.com](http://www.datavideo.com) for answers to common questions, support requests or contact your local office below.

## Datavideo USA

Datavideo Corporation  
7048 Elmer Avenue.  
Whittier, CA 90602,  
U.S.A.  
Tel: +1-562-696 2324  
Fax: +1-562-698 6930  
E-mail: [sales@datavideo.us](mailto:sales@datavideo.us)

## Datavideo The Netherland

Datavideo Technologies Europe BV  
Floridadreef 106  
3565 AM Utrecht,  
The Netherlands  
Tel: +31-30-261-96-56  
Fax: +31-30-261-96-57  
E-mail: [info@datavideo.nl](mailto:info@datavideo.nl)

## Datavideo United Kingdom

Datavideo UK Limited  
Units 1 & 2 Waterside Business Park  
Hadfield, Glossop, Derbyshire  
SK13 1BE, UK  
Tel: +44-1457 851 000  
Fax: +44-1457 850 964  
E-mail: [sales@datavideo.co.uk](mailto:sales@datavideo.co.uk)

## Datavideo Taiwan

Datavideo Technologies Co. Ltd  
10F. No. 176, Jian 1st Rd., Chung Ho  
District, New Taipei City 235, Taiwan,  
R.O.C.  
Tel: +886-2-8227-2888  
Fax: +886-2-8227-2777  
E-mail: [service@datavideo.com.tw](mailto:service@datavideo.com.tw)

## Datavideo China

Datavideo Technologies China Co  
101, NO.618, LiuYing Rd, Zhabei District,  
Shanghai, China  
Tel: +86 21-5603 6599  
Fax: +86 21-5603 6770  
E-mail: [service@datavideo.cn](mailto:service@datavideo.cn)

## Datavideo Singapore

Datavideo Technologies (S) PTE Ltd  
No. 178 Paya Lebar Road #06-03  
Singapore 409030  
Tel: +65-6749 6866  
Fax: +65-6749 3266  
E-mail: [sales@datavideo.sg](mailto:sales@datavideo.sg)

## Datavideo Hong Kong

Datavideo Hong Kong Ltd  
G/F., 26 Cross Lane  
Wanchai, Hong Kong  
Tel: +852-2833-1981  
Fax: +852-2833-9916  
E-mail: [info@datavideo.com.hk](mailto:info@datavideo.com.hk)

## Datavideo France

Datavideo France s.a.r.l  
Cité Descartes 1, rue Albert Einstein  
Champs sur Marne  
774477-Marne la Vallée cedex 2  
Tel: +33-1-60370246  
E-mail: [info@datavideo.fr](mailto:info@datavideo.fr)

## Datavideo India

Datavideo Technologies India Pvt Ltd  
A-132, Sec-63, Noida-201307,  
Uttar Pradesh (UP), India.  
Tel: +91-0120-2427337  
Fax: +91-0120-2427338  
E-mail: [sales@datavideo.in](mailto:sales@datavideo.in)



Please refer to our website for update the latest version manual.  
[www.datavideo.info/PTZ+Camera+and+Control/MCU-100](http://www.datavideo.info/PTZ+Camera+and+Control/MCU-100)

# datavideo®

[www.datavideo.com](http://www.datavideo.com)

All the trademarks are the properties of their respective owners. Datavideo Technologies Co., Ltd.

All rights reserved 2018

May-14.2014 P/N:G082060585E4