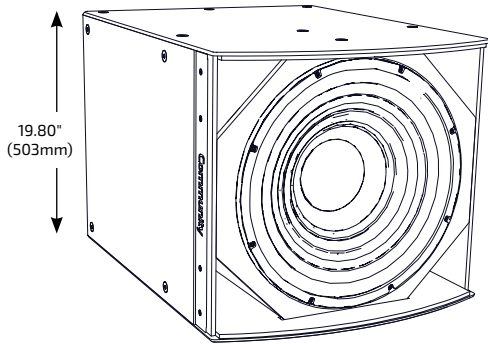

I SERIES

Subwoofer 800

IS8-118

 HIGH POWER SINGLE 18-INCH
SUBWOOFER

APPLICATIONS
SMALL TO MEDIUM SIZE VENUES

 Houses of Worship · Auditoriums · Restaurants
Meeting Rooms · Corporate A/V Systems

LARGER SIZE VENUES

 Arenas · Stadiums · Night Clubs · Theaters
Themed Entertainment · Larger Houses of Worship

DESCRIPTION

I SERIES Subwoofer 800 loudspeakers provide exemplary acoustic performance, modular flexibility and elegant aesthetics for modern performance venues. Designed to support the goals of systems integrators and consultants both acoustically and mechanically, I SERIES Subwoofers provide a broad range of sizes and capabilities that can be specifically matched to the needs of any modern venue.

The compact, low-profile single driver I SERIES subwoofers are ideal for distributed or concealed sub-bass and are the perfect choice for ground stack applications. Additionally, each cabinet was carefully designed to provide matching face widths and suspension point locations for seamless integration into flown arrays with I SERIES full-range models when additional LF extension is needed but a compact appearance is required. The broad range of optional low profile fly rails, fly frames and modular array brackets reduces design and installation time while also providing improved aesthetics and nearly limitless integration possibilities.

The IS8-118 is a compact, direct radiating subwoofer with large, balanced ports that provide optimal enclosure tuning and even air pressure distribution to the driver cones, reducing distortion and extending system longevity. FEA optimized linear suspensions and high flux neodymium motors with long linear excursion capabilities provide exceptionally deep bass for the enclosure's size.

FEATURES

- High-flux, linear neodymium motors with demodulation rings for very low distortion
- Matched-size enclosure and aligned suspension point for seamless flown array integration
- 1600W continuous power handling (6400W peak)
- Long, linear excursion ensures deep, clean bass extension at maximum output
- Isolated driver air volumes allow use of directional steering techniques within a single enclosure

TECHNICAL SPECIFICATIONS¹

Operating Mode	Single Amp		
Operating Environment	Indoor		
Operating Range²	31 Hz to 145 Hz		
Transducer	1 x 18" (457mm) double-treated cone with 4" (102mm) voice coil, triple demodulation rings, neodymium construction		
Continuous Power Handling³ @ Nominal Impedance	Single Amp	113V	1600W @ 8 ohms (6400W peak)
Nominal Sensitivity⁴	Half Space	@ 1W 99 dB	@ 2.83V 99 dB
	Whole Space	93 dB	93 dB
Nominal Maximum SPL⁵	Half Space	Peak 137 dB	Continuous 131 dB
	Whole Space	131 dB	125 dB
Equalized Sensitivity⁶	Half Space	@ 1W 99 dB	@ 2.83V 99 dB
	Whole Space	93 dB	93 dB
Equalized Maximum SPL⁷	Half Space	Peak 137 dB	Continuous 131 dB
	Whole Space	131 dB	125 dB
Recommended Amplifiers	Single Amp	1600W - 3200W @ 8 ohms, (113V - 160V)	
PHYSICAL			
Input Connection	(2) Screw terminal blocks (4-position)		
Mounting Points	(24) M10 threaded rigging points		
Environmental	IPX4 per IEC 60529 , designed in accordance with MIL-STD-810G		
Dimensions/Weight/Finish	Refer to the Technical Drawing		
OPTIONS			
Accessories (Refer to Accessory Guide for complete listing)	Modular rigging kits include: BFR22 : BalancePoint™ Fly Rails; IAB40 : Isometric Array Frame; VAB-BFR54 : Sub Above Vert. Array; HAB : Sub/ Dual 2-Way Horiz. Array; HVS : Multiple Horiz./Vert. Array Kits with Sub Behind Array options; TPK : Tight Pack Kit		
Configure-to-Order (CTO)	Custom color		

IS8-118

HIGH POWER SINGLE 18-INCH
SUBWOOFER

AXIAL PROCESSED RESPONSE (dB)⁸

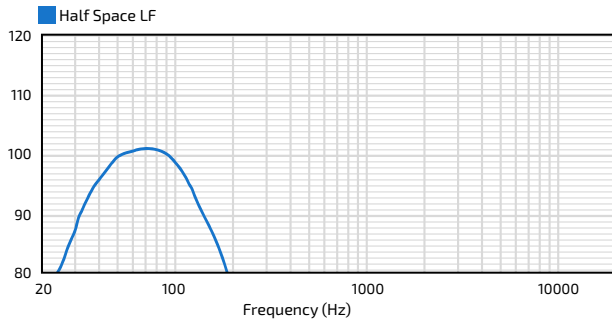

AXIAL SENSITIVITY (dB SPL)⁹

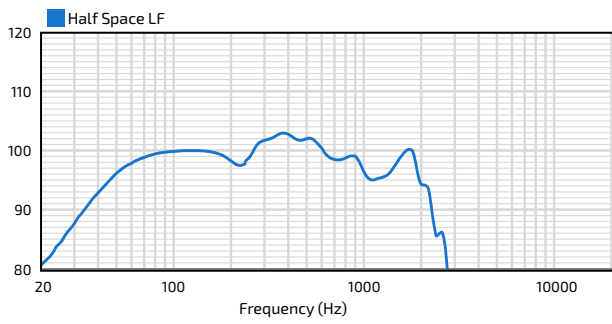

IMPEDANCE (Ohms)

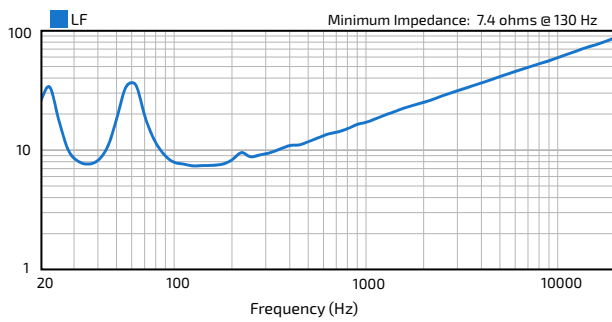

IS8-118

HIGH POWER SINGLE 18-INCH
SUBWOOFER

TECHNICAL DRAWING / DIMENSIONS / FINISH

H x W x D
19.80" x 22.10" x 28.89"
(503 x 561 x 734 mm)

Unit Weight
98 lbs (44.5 kg) loudspeaker only

Shipping Weight
112 lbs (50.8 kg)

Grille:
Powder-coated perforated steel backed with color-matched acoustically transparent woven fabric
Black (RAL#9005) or White (RAL#9003)

Enclosure / Finish
Black (RAL#9004) or White (RAL#9003)
low gloss, uniformly textured painted
15mm Baltic Birch plywood

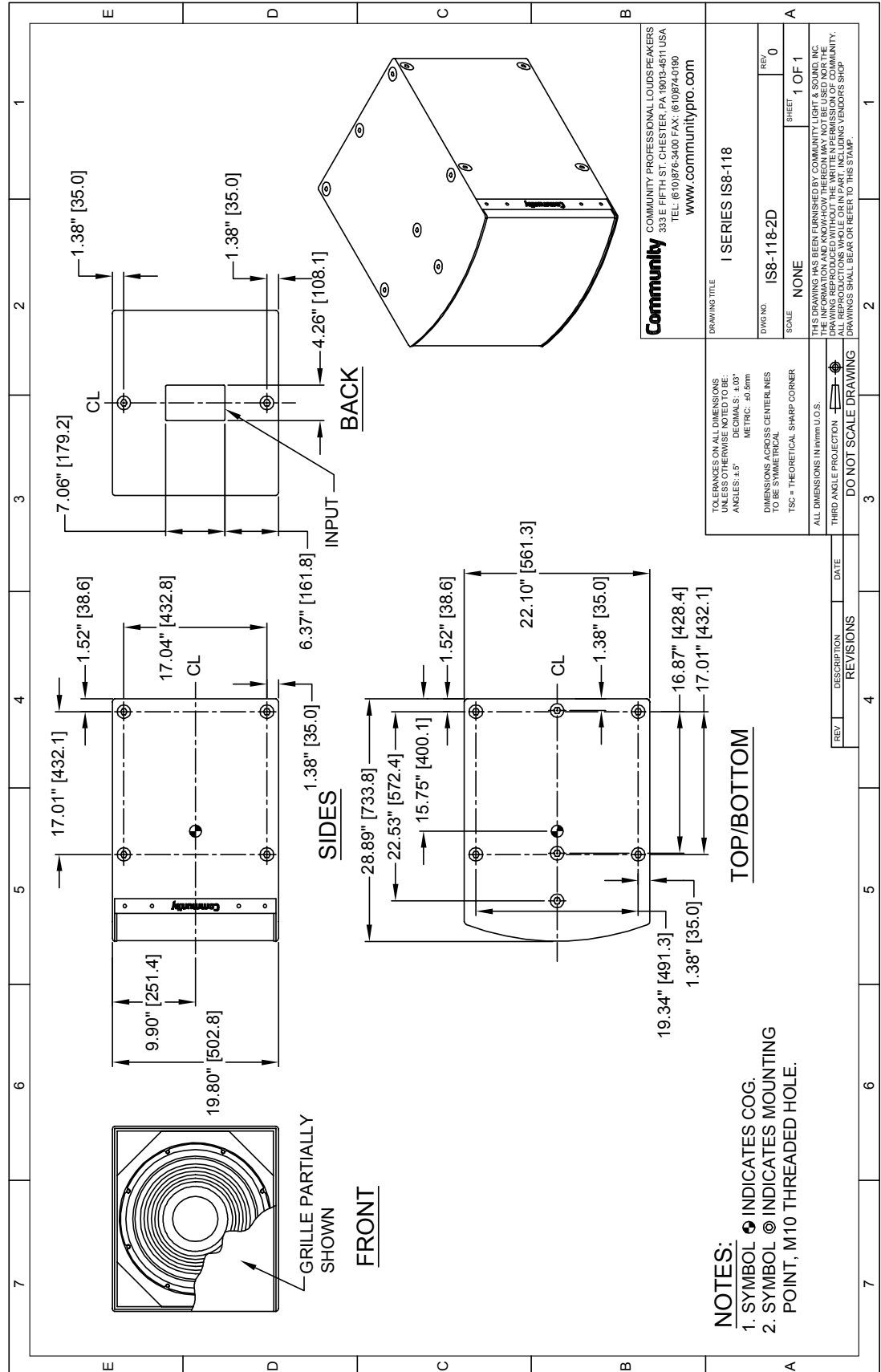

- NOTES:**
1. SYMBOL ● INDICATES COG.
 2. SYMBOL ⊙ INDICATES MOUNTING POINT, M10 THREADED HOLE.

I SERIES

Subwoofer 800

IS8-118

HIGH POWER SINGLE 18-INCH
SUBWOOFER

CONNECTION DIAGRAM

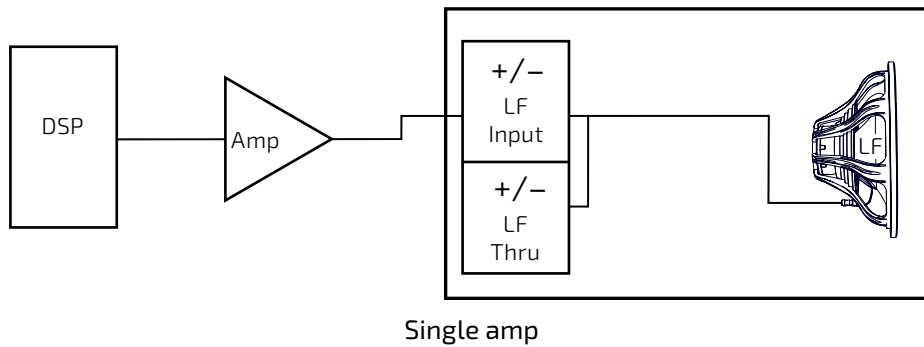

INPUT PANEL

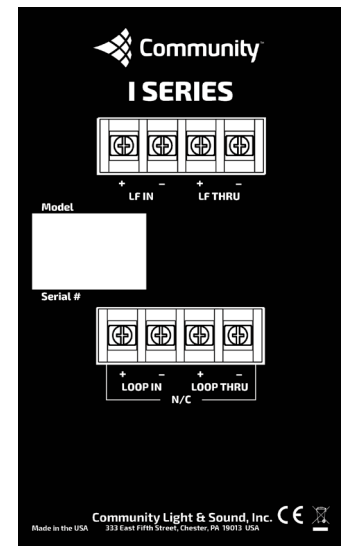

NOTES

- PERFORMANCE SPECIFICATIONS** All measurements are taken indoor using a time-windowed and processed to eliminate room effects, approximating an anechoic environment, a distance of 6.0 m. All acoustic specifications are rounded to the nearest whole number. An external DSP with settings provided by Community Professional Loudspeakers is required to achieve the specified performance; further performance gains can be realized using Community's dSPEC226 loudspeaker processor with FIR power response optimization.
- OPERATING RANGE** The frequency range in which the axial processed response remains within 10dB of the average SPL.
- CONTINUOUS POWER HANDLING** Maximum continuous input voltage (and the equivalent power rating, in watts, at the stated nominal impedance) that the system can withstand, without damage, for a period of 2 hours using an EIA-426-B defined spectrum; with recommended signal processing and protection filters.
- NOMINAL SENSITIVITY** Averaged SPL over the operating range with an input voltage that would produce 1 Watt at the nominal impedance and the averaged SPL over the operating range with an input voltage of 2.83 Volts, respectively; swept sine wave axial measurements with no external processing applied in whole space, except where indicated.
- NOMINAL MAXIMUM SPL** Calculated based on nominal / peak power handling, respectively, and nominal sensitivity; exclusive of power compression.
- EQUALIZED SENSITIVITY** The respective SPL levels produced when an EIA-426-B signal is applied to an equalized loudspeaker system at a level which produces a total power of 1 Watt, in sum, to the loudspeaker subsections and at a level which produces a total voltage, in sum, of 2.83 volts to the loudspeaker subsections, respectively; each referenced to a distance of 1 meter.
- EQUALIZED MAXIMUM SPL** The SPL produced when an EIA-426-B signal is applied to an equalized loudspeaker system, at a level which drives at least one subsection to its rated continuous input voltage limit, referenced to a distance of 1 meter. The peak SPL represents the 2:1 (6dB) crest factor of the EIA-426-B test signal.
- AXIAL PROCESSED RESPONSE** The axial magnitude response of the complete loudspeaker system and each pass band capable of being driven by an independent amplification channel with recommended signal processing applied. 1/6 octave smoothing applied.
- AXIAL SENSITIVITY** The SPL plotted against frequency, in all operating modes and for each pass band capable of being driven by an independent amplification channel, for a 1 Watt swept sine wave, referenced to 1 meter with no signal processing. 1/6 octave smoothing applied.

Data presented on this spec sheet represents a selection of the basic performance specifications for the model. These specifications are intended to allow the user to perform a fair, straightforward evaluation and comparison with other loudspeaker spec sheets. For a detailed analysis of this loudspeaker's performance, please download the GLL file and/or the CLF file from our website: communitypro.com.