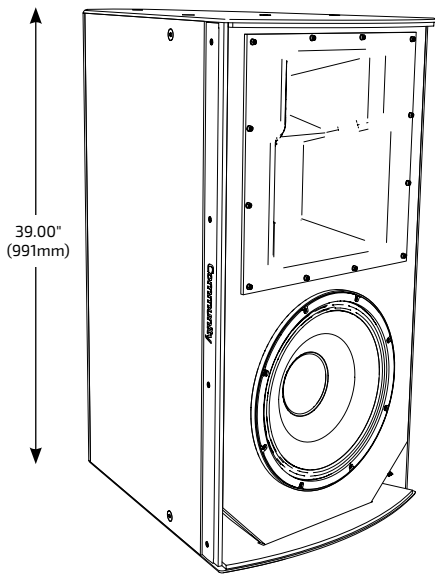

**I SERIES**  
 Point Source 800

# IP8-1153/94

 HIGH POWER 15-INCH THREE-WAY  
 90° x 40° INSTALLATION LOUDSPEAKER

**APPLICATIONS**
**MAIN PA** (*Small to Medium Size Venues*)

 Houses of Worship · Auditoriums · Restaurants  
 Meeting Rooms · Theaters · Corporate A/V Systems

**DISTRIBUTED OR FILL** (*Larger Size Venues*)

 Arenas · Stadiums · Night Clubs · Theaters  
 Themed Entertainment · Larger Houses of Worship

**DESCRIPTION**

I SERIES Point Source 800 loudspeakers provide exemplary acoustic performance, modular flexibility and elegant aesthetics for modern performance venues. Designed to support the goals of systems integrators and consultants both acoustically and mechanically, I SERIES includes a wide variety of arrayable, rotatable coverage patterns and a comprehensive selection of modular bracket systems that accelerate system design and system commissioning.

FEA-optimized linear suspensions, high-flux neodymium motors, and integral demodulation rings ensure precise transducer motion control and very low distortion at high SPL levels. The custom long-excursion LF driver delivers deep bass response and a balanced midrange in the most demanding applications. The matched diaphragms on the HF and MF compression drivers provide natural, transparent sound quality with unrivaled intelligibility and transient response accuracy that complements any source.

The rotatable 18-inch (457mm) MF/HF waveguide provides well-defined coverage and a smooth off-axis response that enhances arrayability. The acoustic 8th order MF/HF passive crossover produces a smooth, consistent vertical off-axis response free from the polar lobing and power response losses inherent in similar systems. User selectable biamp or triamp operating modes further expand performance capabilities.

**FEATURES**

- Matching ketone polymer MF/HF diaphragms provide uniform sound quality from 500Hz to 20 kHz
- M200HP midrange compression driver for signature Community intelligibility and low distortion
- FEA-optimized suspensions and neodymium motors with integral demodulation rings in LF and HF
- Large rotatable waveguide, user selectable biamp or triamp operation
- Innovative low profile modular bracket systems create elegant arrays with simplified installation

**TECHNICAL SPECIFICATIONS<sup>1</sup>**

<b>Operating Mode</b>	Biamp or Triamp with DSP		
<b>Operating Environment</b>	Indoor		
<b>Operating Range<sup>2</sup></b>	30 Hz to 16.5 kHz		
<b>Nominal Beamwidth (H x V)</b>	90° x 40°, rotatable waveguide		
<b>Transducers</b>	LF – 1 x 15" (381mm) neodymium motor woofer, 3" (76mm) voice coil, demodulation ring MF – M200HP, 2" exit, ketone polymer diaphragm, compression driver HF – 1 x 1.4" (36mm) exit neodymium compression driver, 2.6" (66mm) voice coil, demodulation ring, ketone polymer diaphragm		
<b>Continuous Power Handling<sup>3</sup> @ Nominal Impedance</b>	LF	69V	600W @ 8 ohms (2400W peak)
	MF	35V	150W @ 8 ohms (600W peak)
	HF	32V	125W @ 8 ohms (500W peak)
	MF/HF	47V	275W @ 8 ohms (1100W peak)
<b>Nominal Sensitivity<sup>4</sup></b>		@ 1W	@ 2.83V
	LF	96 dB	96 dB
	MF	106 dB	106 dB
	HF	106 dB	106 dB
	MF/HF	106 dB	106 dB
<b>Nominal Maximum SPL<sup>5</sup> (Whole Space)</b>		<b>Peak</b>	<b>Continuous</b>
	LF	130 dB	124 dB
	MF	134 dB	128 dB
	HF	133 dB	127 dB
	MF/HF	136 dB	130 dB
<b>Equalized Sensitivity<sup>6</sup></b>	System	@ 1W 94 dB	@ 2.83V 94 dB
<b>Equalized Maximum SPL<sup>7</sup></b>	System	<b>Peak</b> 128 dB	<b>Continuous</b> 122 dB
<b>Recommended Amplifiers</b>	LF	600W - 1200W @ 8 ohms, (69V - 98V)	
	MF	150W - 300W @ 8 ohms, (35V - 49V)	
	HF	125W - 250W @ 8 ohms (32V - 45V)	
	MF/HF	275W - 550W @ 8 ohms, (47V - 66V)	

**PHYSICAL**

<b>Input Connection</b>	(2) Screw terminal blocks (6-position)
<b>Mounting Points</b>	(15) M10 threaded rigging points
<b>Environmental</b>	IPX4 per IEC 60529, designed in accordance with MIL-STD-810G
<b>Dimensions/Weight/Finish</b>	Refer to the Technical Drawing page

**OPTIONS**

<b>Accessories</b> (Refer to Accessory Guide for complete listing)	<i>Rigging kits include:</i> <b>BFR22:</b> BalancePoint™ Fly Rails; <b>IUB1153:</b> U-Bracket; <b>IVY1153:</b> Vertical Yoke; <b>IAF55:</b> Isometric Array Frame; <b>VAB-BFR38:</b> Sub Above Vert Array; <b>HAB3-BFR38:</b> Sub/Dual 3-Way Horiz Array; <b>HSB3/VSB3:</b> Multiple Splay Brackets for Horiz/Vert Arrays with Sub Behind options; <b>DFS:</b> Downfill Splay Kit; <b>DVS-BFR22:</b> Dual Vert Splay Kit with BalancePoint™ Fly Rails; <b>TPK:</b> Tight Pack Kit
<b>Configure-to-Order (CTO)</b>	Custom color

### AXIAL PROCESSED RESPONSE (dB)<sup>8</sup>

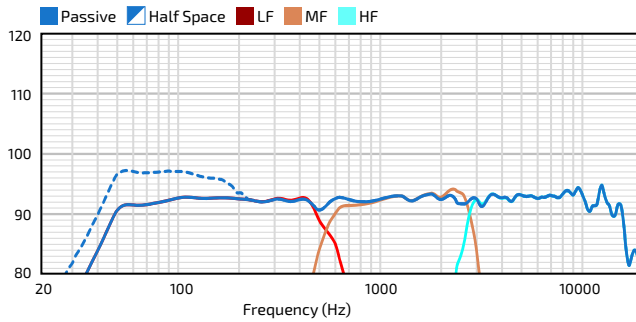

### HORIZONTAL OFF-AXIS RESPONSE (dB)<sup>10</sup>

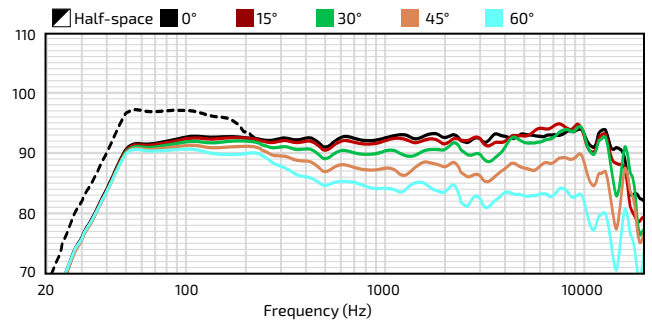

### AXIAL SENSITIVITY (dB SPL)<sup>9</sup>

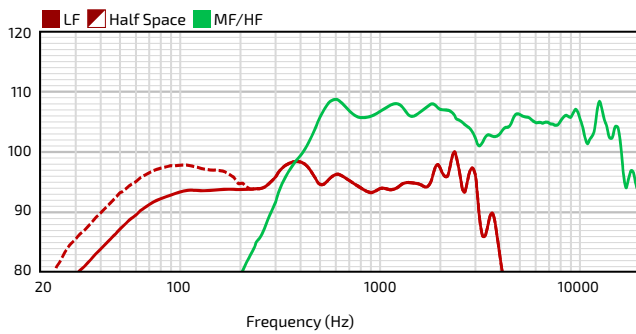

### VERTICAL OFF-AXIS UP RESPONSE (dB)<sup>10</sup>

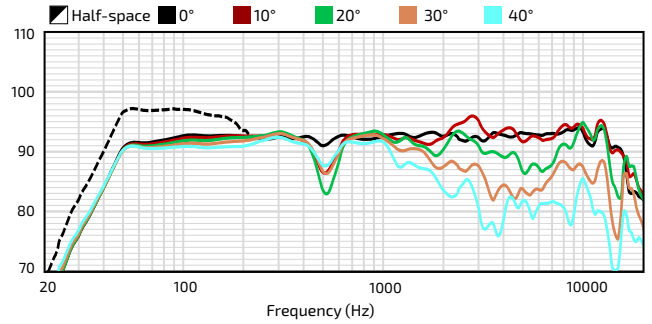

### IMPEDANCE (Ohms)

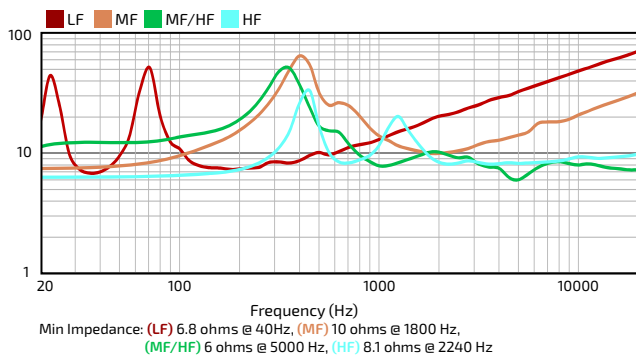

### VERTICAL OFF-AXIS DOWN RESPONSE (dB)<sup>10</sup>

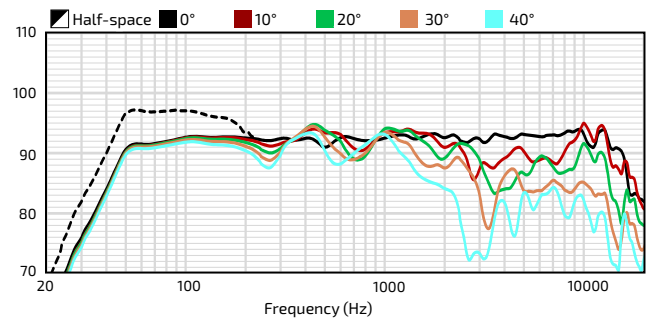

### DIRECTIVITY INDEX (dB)<sup>11</sup>

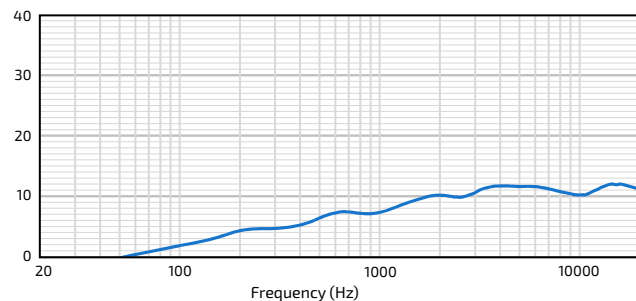

### BEAMWIDTH (Degrees)<sup>12</sup>

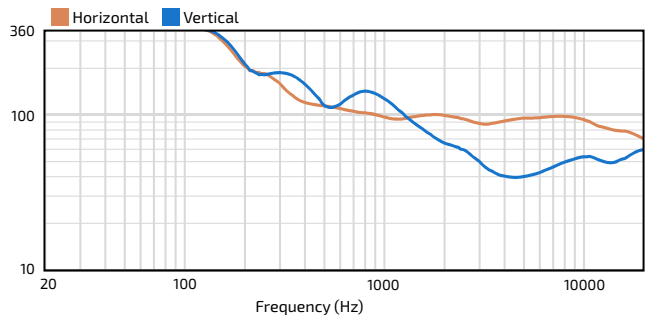

## HORIZONTAL POLAR DATA (30dB Scale, 6dB per major division)

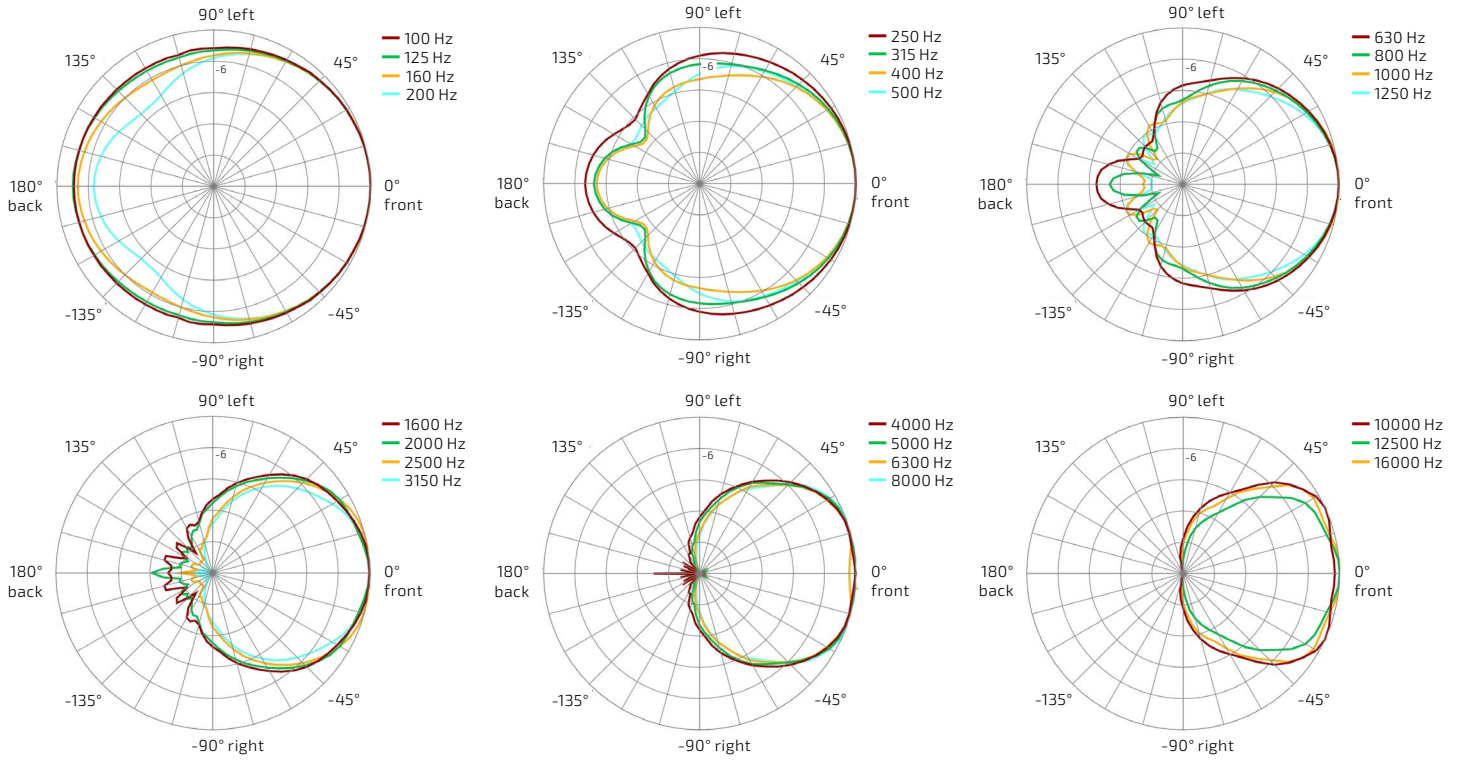

## VERTICAL POLAR DATA (30dB Scale, 6dB per major division)

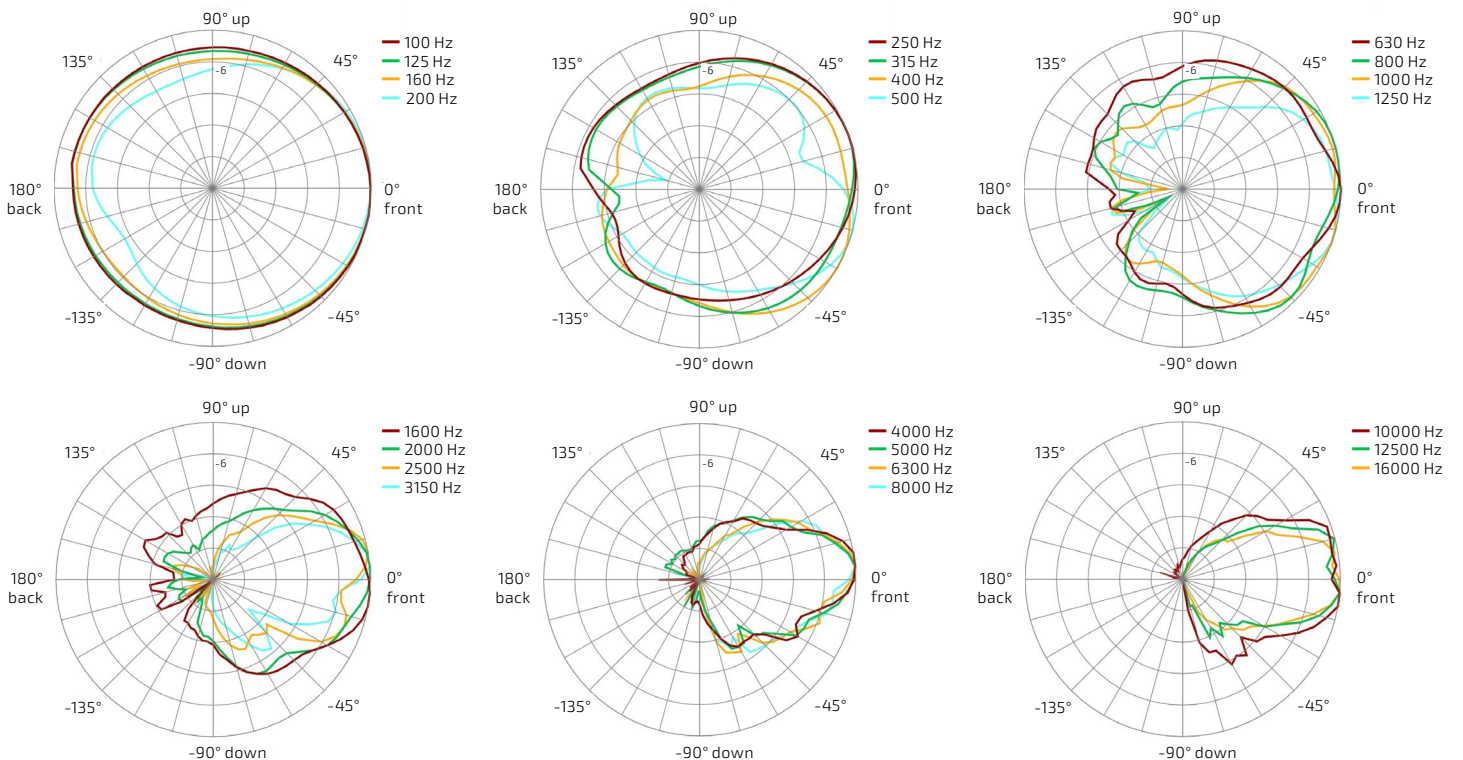

# IP8-1153/94

HIGH POWER 15-INCH THREE-WAY  
90° x 40° INSTALLATION LOUDSPEAKER

## TECHNICAL DRAWING / DIMENSIONS / FINISH

**H x W x D**  
39.00" x 22.10" x 26.30"  
(991 x 561 x 668 mm)

**Unit Weight**  
105 lbs (47.6 kg) loudspeaker only  
**Shipping Weight**  
124 lbs (56.2 kg)

**Grille:**  
Powder-coated perforated steel backed with color-matched acoustically transparent woven fabric. Black (RAL#9005) or White (RAL#9003)

**Enclosure / Finish**  
Black (RAL#9004) or White (RAL#9003) low gloss, uniformly textured painted 15mm Baltic Birch plywood

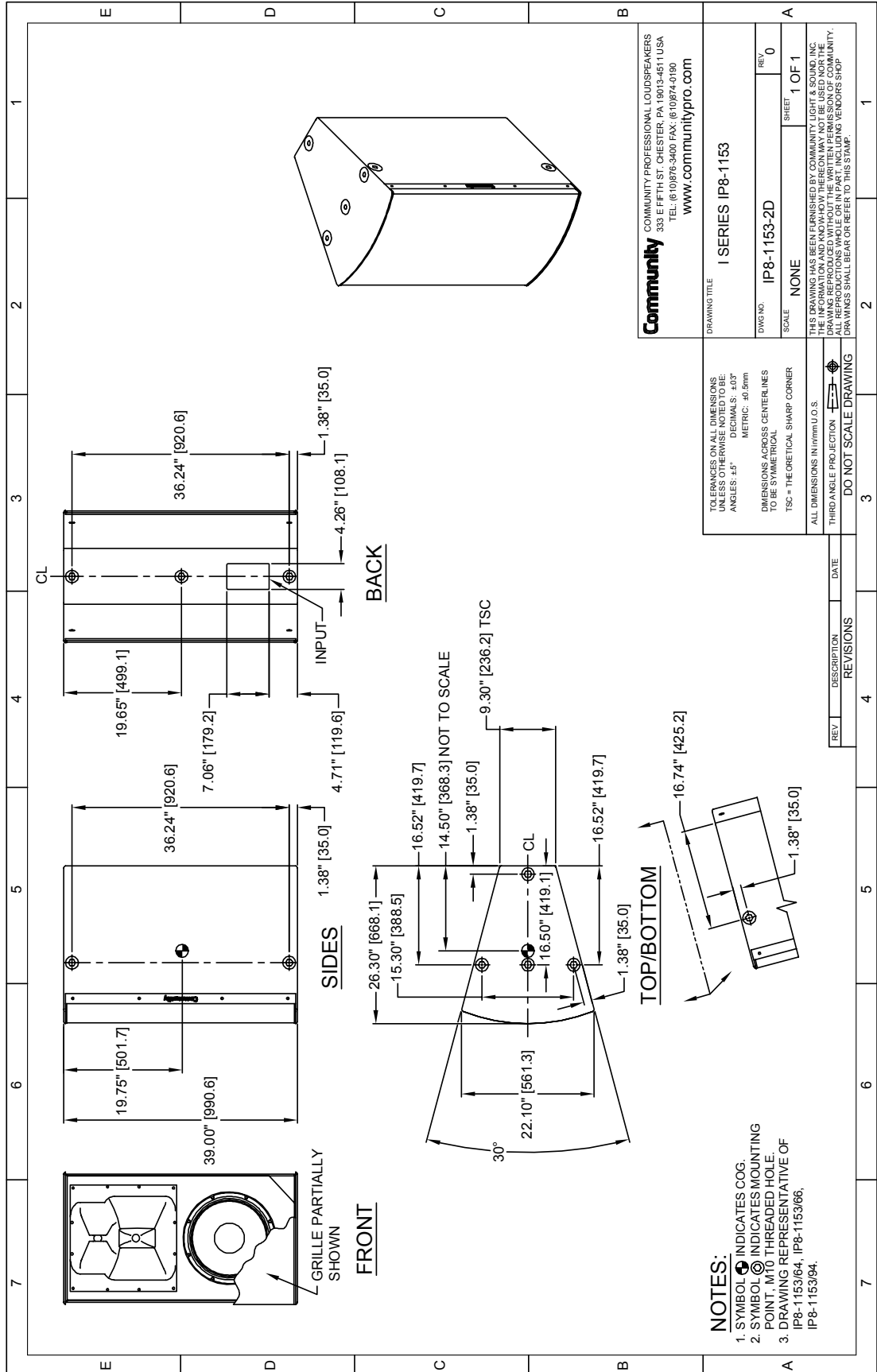

## I SERIES

Point Source 800

# IP8-1153/94

HIGH POWER 15-INCH THREE-WAY  
90° x 40° INSTALLATION LOUDSPEAKER

### CONNECTION DIAGRAMS

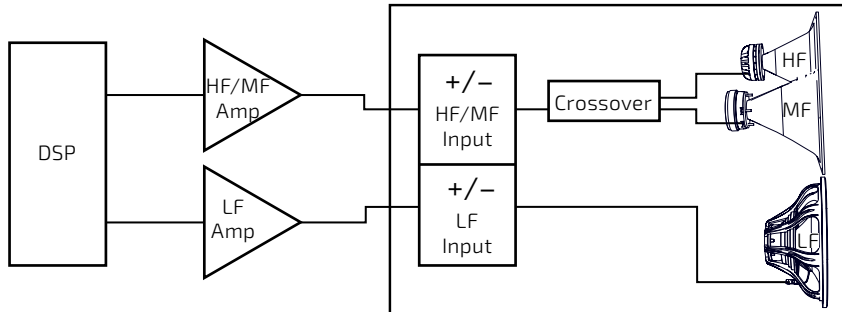

Three-way biamp

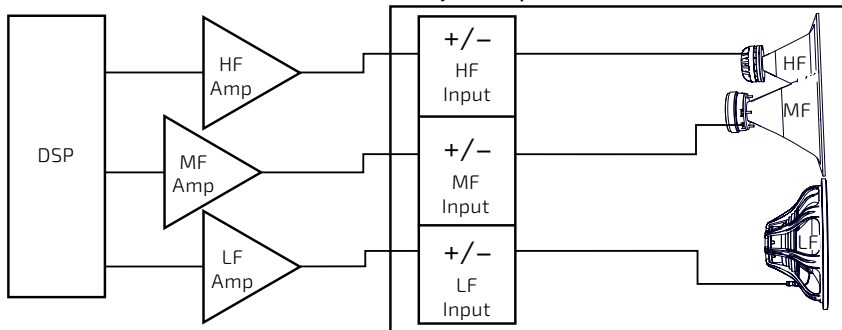

Three-way triamp

### INPUT PANEL

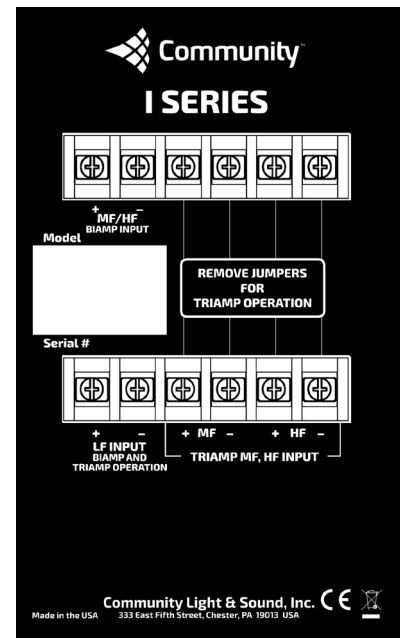

Three-way input panel

### NOTES

- PERFORMANCE SPECIFICATIONS** All measurements are taken indoor using a time-windowed and processed signal to eliminate room effects, approximating an anechoic environment, a distance of 6.0 m. All acoustic specifications are rounded to the nearest whole number. An external DSP with settings provided by Community Professional Loudspeakers is required to achieve the specified performance; further performance gains can be realized using Community's dSPEC226 loudspeaker processor with FIR power response optimization.
- OPERATING RANGE** The frequency range in which the on-axis processed response remains within 10dB of the average SPL.
- CONTINUOUS POWER HANDLING** Maximum continuous input voltage (and the equivalent power rating, in watts, at the stated nominal impedance) that the system can withstand, without damage, for a period of 2 hours using an EIA-426-B defined spectrum; with recommended signal processing and protection filters.
- NOMINAL SENSITIVITY** Averaged SPL over the operating range with an input voltage that would produce 1 Watt at the nominal impedance and the averaged SPL over the operating range with a fixed input voltage of 2.83V, respectively; swept sine wave axial measurements with no external processing applied in whole space, except where indicated.
- NOMINAL MAXIMUM SPL** Calculated based on nominal / peak power handling, respectively, and nominal sensitivity; exclusive of power compression.
- EQUALIZED SENSITIVITY** The respective SPL levels produced when an EIA-426-B signal is applied to the equalized loudspeaker system at a level which produces a total power of 1 Watt, in sum, to the loudspeaker subsections and also at a level which produces a total voltage, in sum, of 2.83V to the loudspeaker subsections, respectively; each referenced to a distance of 1 meter.
- EQUALIZED MAXIMUM SPL** The SPL produced when an EIA-426-B signal is applied to the equalized loudspeaker system, at a level which drives at least one subsection to its rated continuous input voltage limit, referenced to a distance of 1 meter. The peak SPL represents the 2:1 (6dB) crest factor of the EIA-426-B test signal.
- AXIAL PROCESSED RESPONSE** The on-axis variation in acoustic output level with frequency of the complete loudspeaker system with recommended signal processing applied. 1/6 octave Gaussian smoothing applied.
- AXIAL SENSITIVITY** The on-axis variation in acoustic output level with frequency for a 1 Watt swept sine wave, referenced to 1 meter with no signal processing. 1/6 octave Gaussian smoothing applied.
- HORIZONTAL / VERTICAL OFF-AXIS RESPONSES** The loudspeaker's magnitude response at various angles off-axis, with recommended signal processing applied in the operating mode which utilizes the largest number of individually amplified pass bands. 1/6 octave Gaussian smoothing applied.
- DIRECTIVITY INDEX** The ratio of the on-axis SPL squared to the mean squared SPL at the same distance for all points within the measurement sphere for each given frequency; expressed in dB. 1/6 octave Gaussian smoothing applied.
- BEAMWIDTH** The angle between the -6dB points in the polar response of the loudspeaker when driven in the operating mode which utilizes the largest number of individually amplified pass bands. 1/6 octave Gaussian smoothing applied.

Data presented on this spec sheet represents a selection of the basic performance specifications for the model. These specifications are intended to allow the user to perform a fair, straightforward evaluation and comparison with other loudspeaker spec sheets. For a detailed analysis of this loudspeaker's performance, please download the GLL file and/or the CLF file from our website: [communitypro.com](http://communitypro.com)