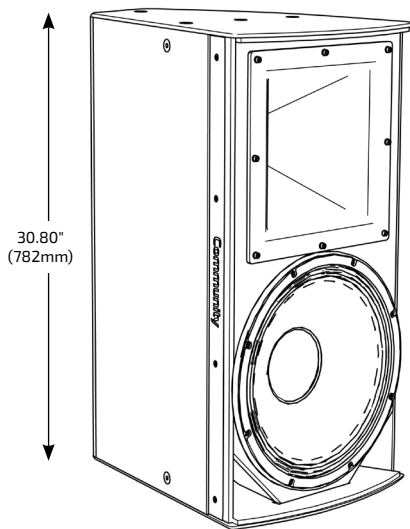

I SERIES
 Point Source 800

IP8-1152/99

 HIGH POWER 15-INCH TWO-WAY
 90° x 90° INSTALLATION LOUDSPEAKER

APPLICATIONS

MAIN PA (Small to Medium Size Venues)

 Houses of Worship · Auditoriums · Restaurants
 Meeting Rooms · Theaters · Corporate A/V Systems

DISTRIBUTED OR FILL (Larger Size Venues)

 Arenas · Stadiums · Night Clubs · Theaters
 Themed Entertainment · Larger Houses of Worship

DESCRIPTION

I SERIES Point Source 800 loudspeakers provide exemplary acoustic performance, modular flexibility and elegant aesthetics for modern performance venues. Designed to support the goals of systems integrators and consultants both acoustically and mechanically, I SERIES includes a wide variety of arrayable, rotatable coverage patterns and a comprehensive selection of modular bracket systems that accelerate system design and system commissioning.

FEA-optimized linear suspensions, high-flux neodymium motors, and integral demodulation rings ensure precise transducer motion control and very low distortion at high SPL levels. The custom long-excursion LF driver delivers deep bass response and a balanced midrange in the most demanding applications. The HF compression driver's non-metallic diaphragm provides natural, transparent sound quality that accurately reproduces and complements any source.

The rotatable 13-inch (330mm) HF waveguide provides well-defined coverage and a smooth off-axis response that enhances arrayability. Individually voiced crossovers produce proper beamwidth matching transitions and identical sonic signatures throughout the product line, permitting horn patterns to be mixed throughout an installation. Additionally, user selectable single-amp or biamp operating modes expand application flexibility.

FEATURES

- High-flux, linear neodymium motors with demodulation rings for very low distortion
- Exceptional sound quality and clarity at very high output levels
- Lightweight and compact with deep LF extension
- Large rotatable waveguide with individually voiced crossover, single amp / biamp selectable
- Innovative low profile modular bracket systems create elegant arrays with simplified installation

TECHNICAL SPECIFICATIONS¹

Operating Mode	Passive or Biamp with DSP		
Operating Environment	Indoor		
Operating Range²	29 Hz to 19.5 kHz		
Nominal Beamwidth (H x V)	90° x 90°, rotatable waveguide		
Transducers	LF 1 x 15" (381mm) neodymium driver, 3" (76mm) voice coil, demodulation ring HF 1 x 1.4" (36mm) exit compression, 2.6" (66mm) voice coil, demodulation ring, ketone polymer diaphragm, neodymium compression driver		
Continuous Power Handling³ @ Nominal Impedance	Passive* LF HF	80V 69V 25V	800W @ 8 ohms (3200W peak) 600W @ 8 ohms (2400W peak) 80W @ 8 ohms (320W peak)
Nominal Sensitivity⁴	Passive LF HF	@ 1W 94 dB 95 dB 104 dB	@ 2.83V 94 dB 95 dB 104 dB
Nominal Maximum SPL⁵ (Whole Space)	Passive LF HF	Peak 129 dB 129 dB 129 dB	Continuous 123 dB 123 dB 123 dB
Equalized Sensitivity⁶	System	@ 1W 93 dB	@ 2.83V 93 dB
Equalized Maximum SPL⁷	System	Peak 128 dB	Continuous 122 dB
Recommended Amplifiers	Passive LF HF	800W - 1600W @ 8 ohms, (80V - 113V) 600W - 1200W @ 8 ohms, (69V - 98V) 80W - 160W @ 8 ohms (25V - 36V)	
PHYSICAL			
Input Connection	(2) Screw terminal blocks (6-position)		
Mounting Points	(15) M10 threaded rigging points		
Environmental	IPX4 per IEC 60529, designed in accordance with MIL-STD-810G		
Dimensions/Weight/Finish	Refer to the Technical Drawing		
OPTIONS			
Accessories (Refer to Accessory Guide for complete listing)	Rigging kits include: BFR22 : BalancePoint™ Fly Rails; IUB1152 : U-Bracket; IVY1152 : Vertical Yoke; IAF40/IAF55 : Isometric Array Frames; VAB-BFR38 : Sub Above Vert Array; HAB-BFR38 : Sub/Dual 2-Way Horiz Array; HSB/VSB : Multiple Splay Brackets for Horiz/Vert Arrays with/without Sub Behind options; DFS : Downfill Splay Kit; DVS-BFR22 : Dual Vert Splay Kit with BalancePoint™ Fly Rails; TPK : Tight Pack Kit		
Configure-to-Order (CTO)	Custom color		

¹Rated continuous maximum input voltage at passive loudspeaker input may be higher than for directly connected transducers due to losses in the passive crossover. Voltages applied to the transducer terminals through the passive crossover shall always be the same or lower than the rated continuous voltage for each device.

AXIAL PROCESSED RESPONSE (dB)⁸

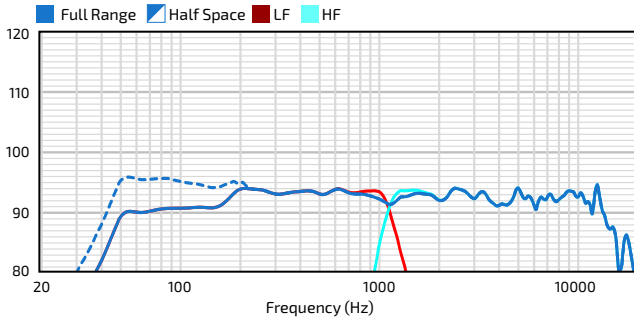

HORIZONTAL OFF-AXIS RESPONSE (dB)¹⁰

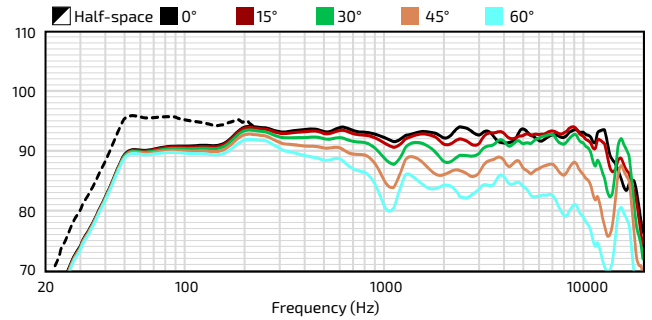

AXIAL SENSITIVITY (dB SPL)⁹

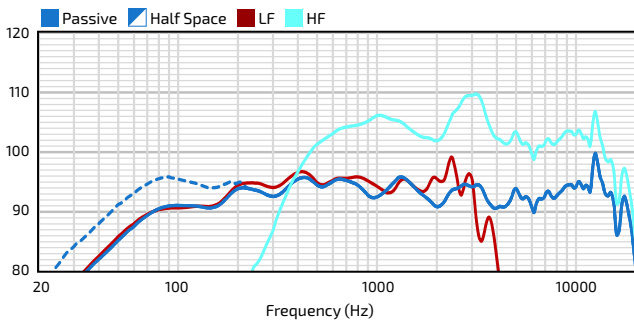

VERTICAL OFF-AXIS UP RESPONSE (dB)¹⁰

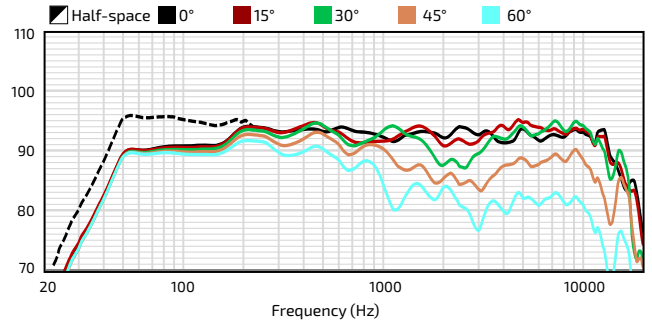

IMPEDANCE (Ohms)

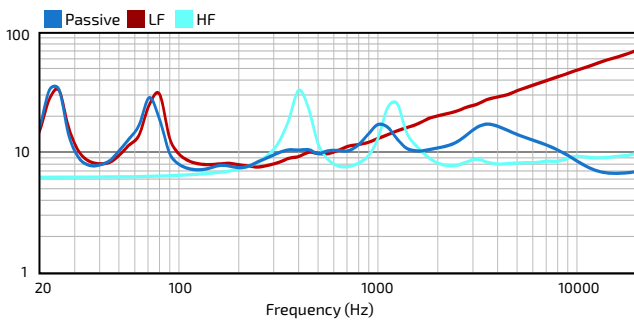

Minimum Impedance:
(Passive) 6.7 ohms @ 16000 Hz, (LF) 7.6 ohms @ 250 Hz, (HF) 7.6 ohms @ 710 Hz

VERTICAL OFF-AXIS DOWN RESPONSE (dB)¹⁰

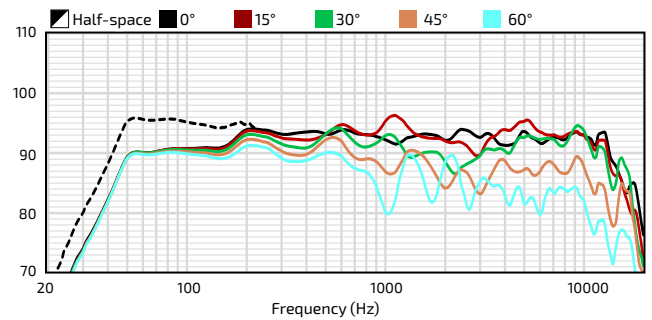

DIRECTIVITY INDEX (dB)¹¹

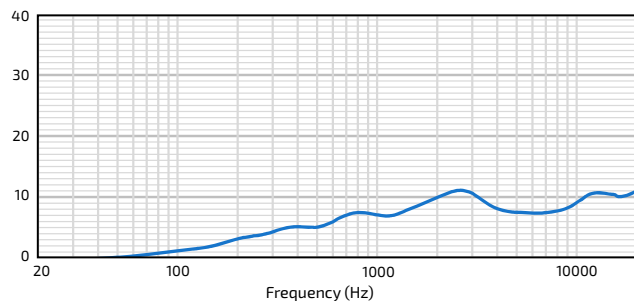

BEAMWIDTH (Degrees)¹²

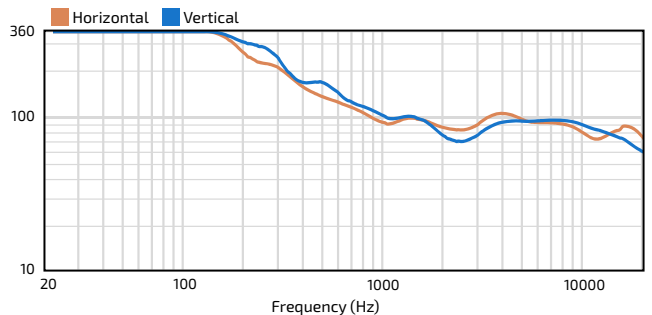

HORIZONTAL POLAR DATA (30dB Scale, 6dB per major division)

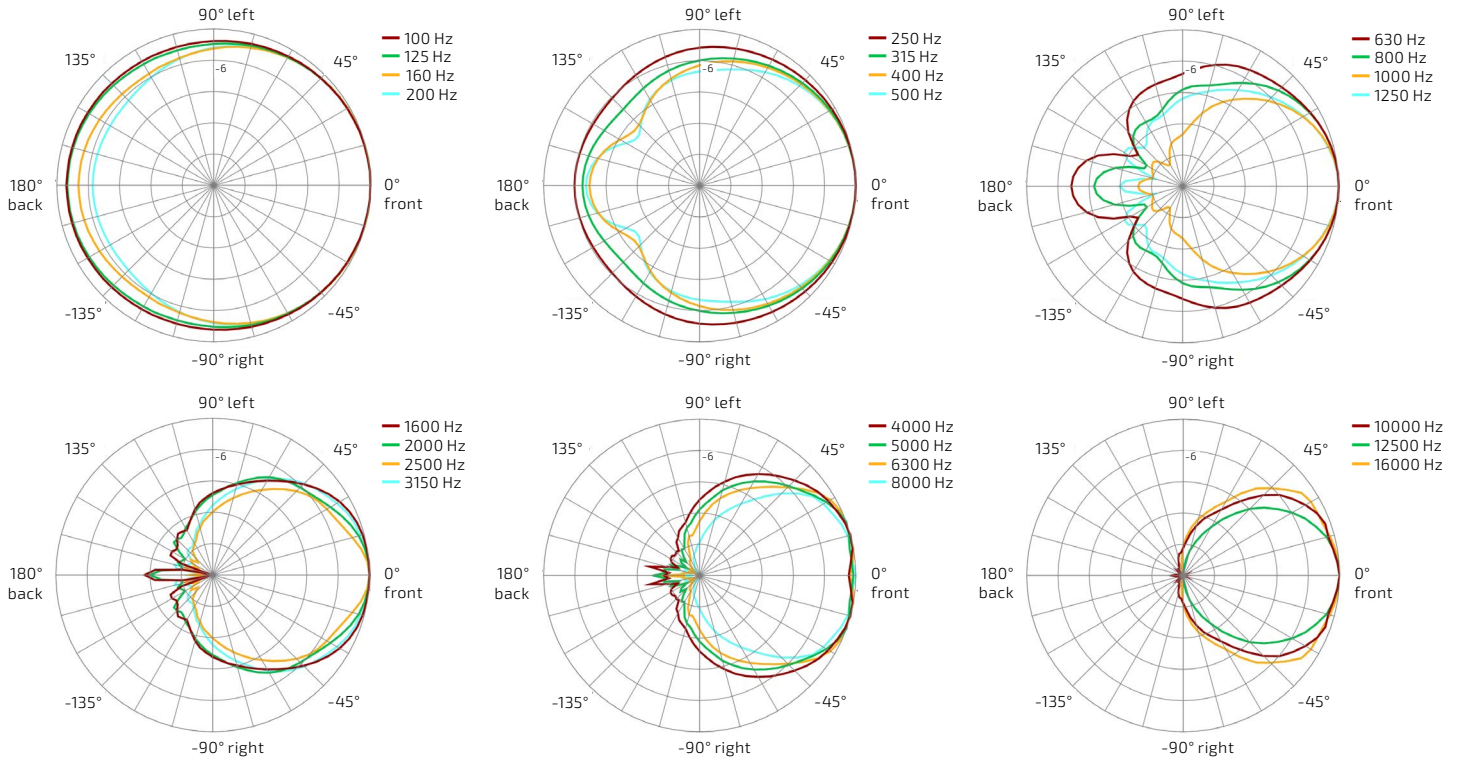

VERTICAL POLAR DATA (30dB Scale, 6dB per major division)

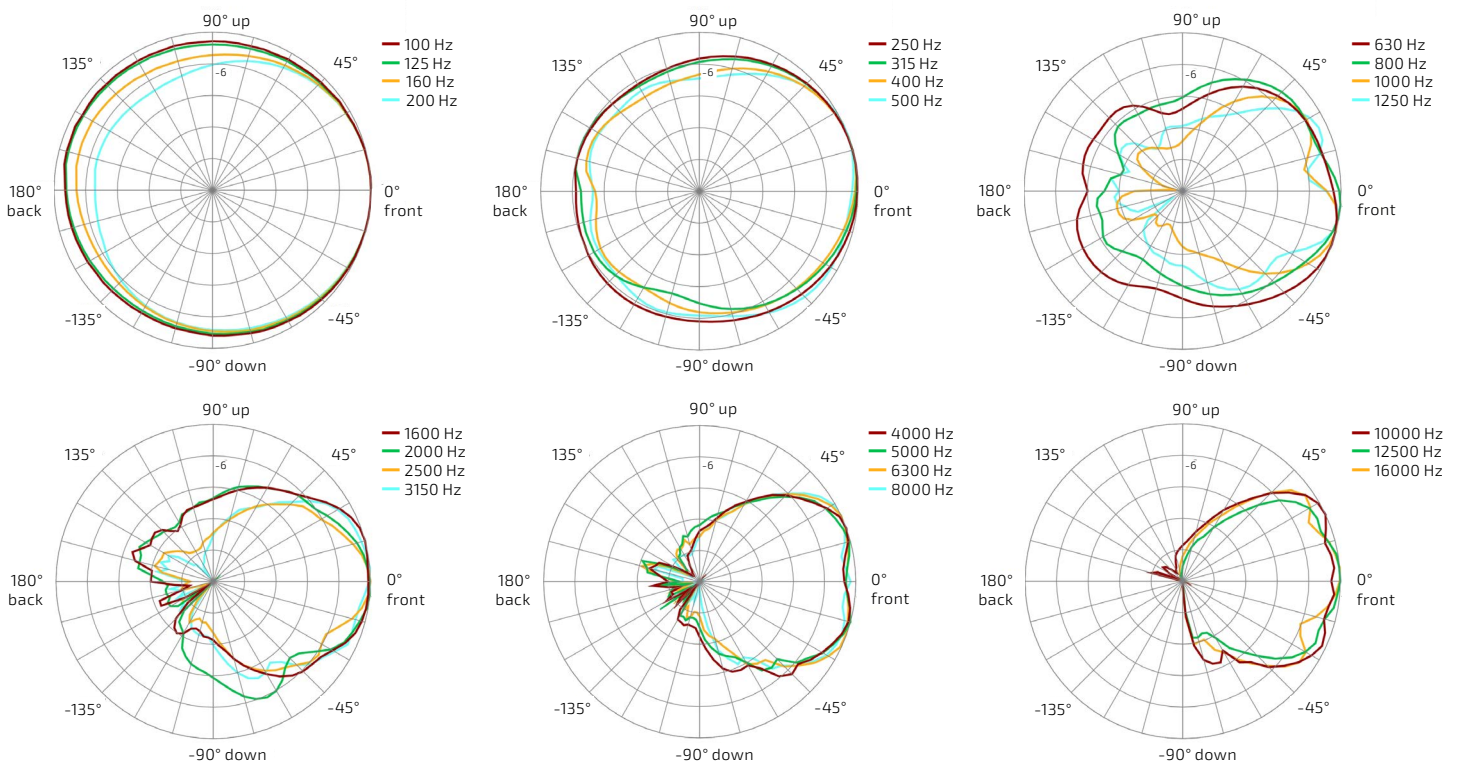

IP8-1152/99

HIGH POWER 15-INCH TWO-WAY
90° x 90° INSTALLATION LOUDSPEAKER

TECHNICAL DRAWING / DIMENSIONS / FINISH

H x W x D
30.80" x 16.50" x 20.07"
(782 x 419 x 510 mm)

Unit Weight
68 lbs (30.8 kg) loudspeaker only
Shipping Weight
81.0 lbs (36.7 kg)

Grille:
Powder-coated perforated steel backed with color-matched acoustically transparent woven fabric. Black (RAL#9005) or White (RAL#9003)

Enclosure / Finish
Black (RAL#9004) or White (RAL#9003) low gloss, uniformly textured painted 15mm Baltic Birch plywood

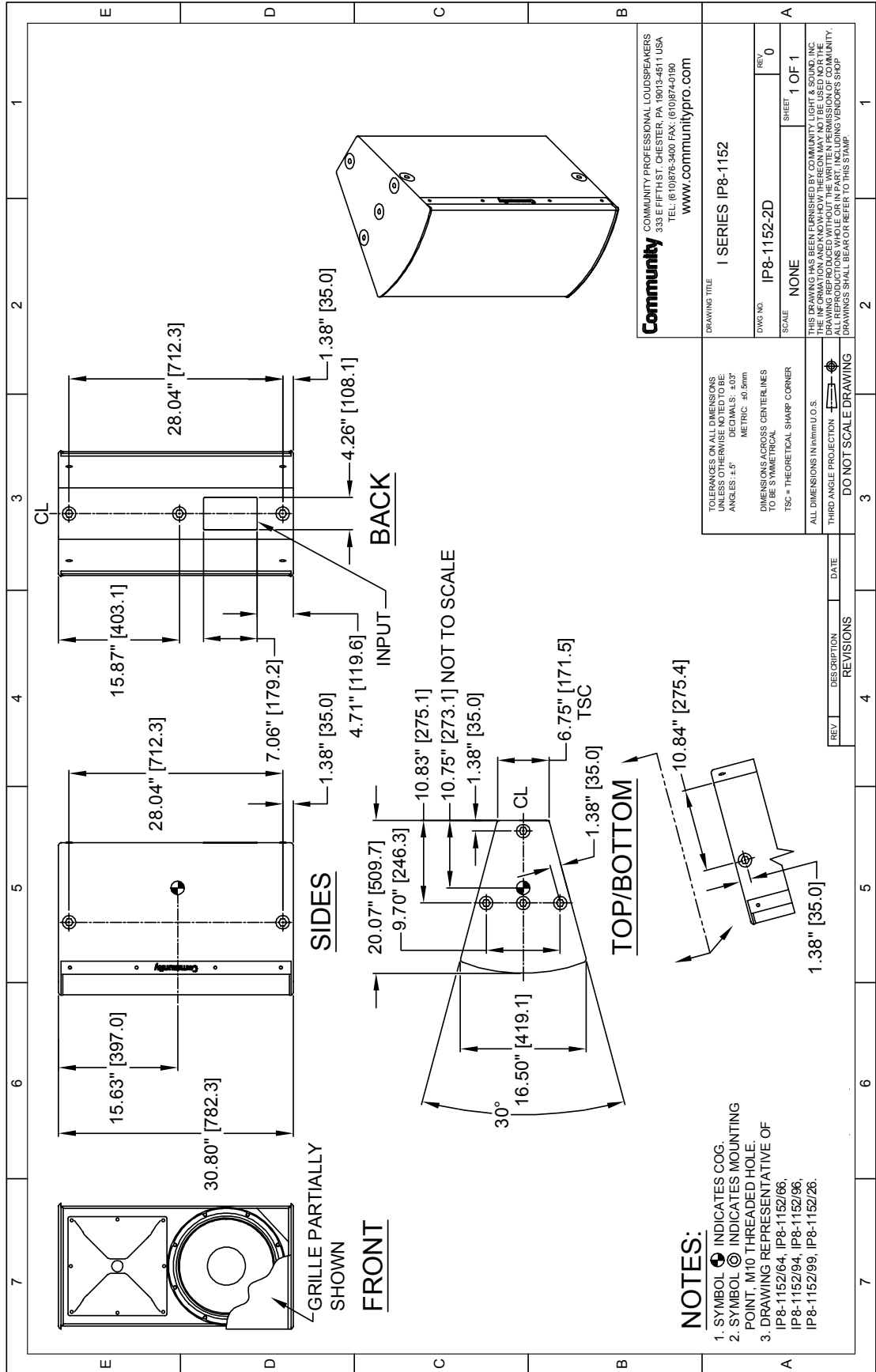

Community COMMUNITY PROFESSIONAL LOUDSPEAKERS
332 E. FIFTH ST. CHESTER, PA 19013-4511 USA
TEL: (610)875-3400 FAX: (610)874-0180
www.communitypro.com

DRAWING TITLE		I SERIES IP8-1152	
DWG NO.	IP8-1152-2D	SHEET	1 OF 1
SCALE	NONE	REV.	0

ALL DIMENSIONS IN INCHES UNLESS OTHERWISE NOTED TO BE METRIC.
DECIMALS: 1/32
ANGLES: 1/4°
DIMENSIONS ACROSS CENTER LINES TO BE SHOWN UNLESS OTHERWISE NOTED TO BE THEORETICAL SHARP CORNER
TSC = THEORETICAL SHARP CORNER
ALL DIMENSIONS IN INCHES UNLESS OTHERWISE NOTED TO BE METRIC.
THIRD ANGLE PROJECTION
DO NOT SCALE DRAWING

- NOTES:**
1. SYMBOL Ⓞ INDICATES COG. POINT, M10 THREADED HOLE.
 2. SYMBOL Ⓢ INDICATES MOUNTING POINT, M10 THREADED HOLE.
 3. DRAWING REPRESENTATIVE OF IP8-1152/64, IP8-1152/66, IP8-1152/94, IP8-1152/96, IP8-1152/99, IP8-1152/26.

THIS DRAWING HAS BEEN FINISHED BY COMMUNITY LIGHT & SOUND INC. THE INFORMATION AND KNOW-HOW THEREON MAY NOT BE USED FOR THE DRAWING REPRODUCED WITHOUT THE WRITTEN PERMISSION OF COMMUNITY. COMMUNITY LIGHT & SOUND INC. MAKING VENDOR'S SHOP DRAWINGS SHALL BEAR OR REFER TO THIS STAMP.

I SERIES

Point Source 800

IP8-1152/99

HIGH POWER 15-INCH TWO-WAY
90° x 90° INSTALLATION LOUDSPEAKER

CONNECTION DIAGRAMS

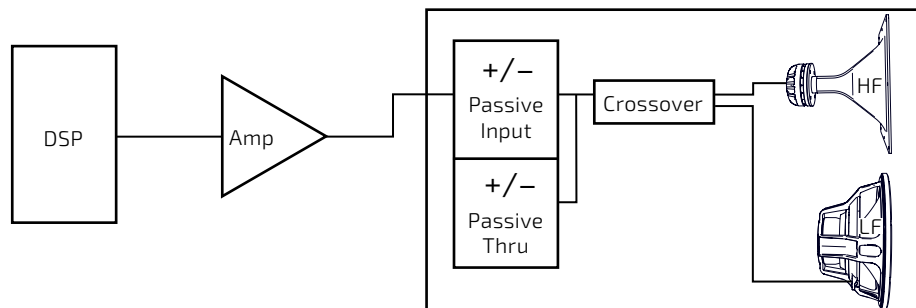

Two-way single amp

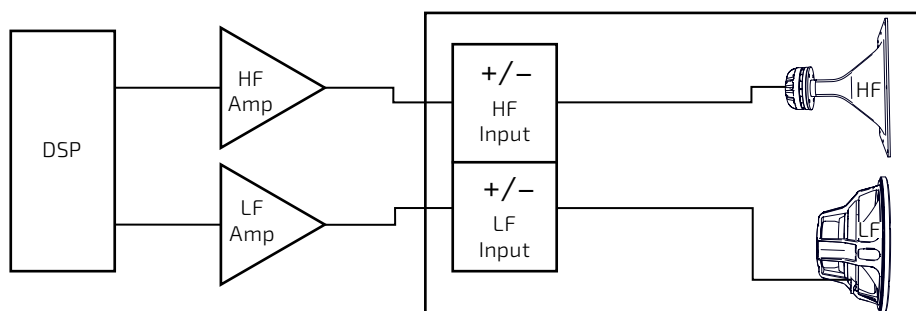

Two-way biamp

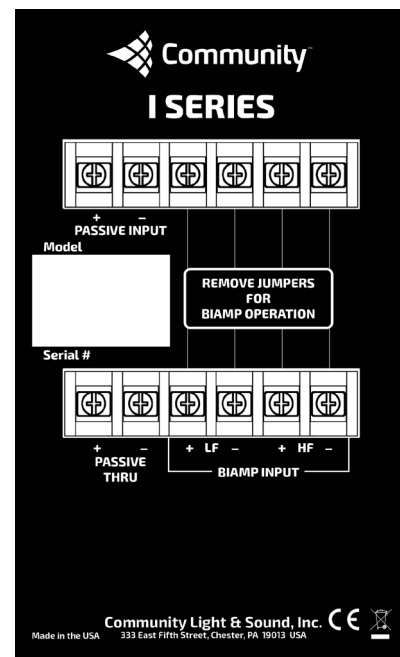

Two-way input panel

NOTES

- PERFORMANCE SPECIFICATIONS** All measurements are taken indoor using a time-windowed and processed signal to eliminate room effects, approximating an anechoic environment, a distance of 6.0 m. All acoustic specifications are rounded to the nearest whole number. An external DSP with settings provided by Community Professional Loudspeakers is required to achieve the specified performance; further performance gains can be realized using Community's dSPEC226 loudspeaker processor with FIR power response optimization.
- OPERATING RANGE** The frequency range in which the on-axis processed response remains within 10dB of the average SPL.
- CONTINUOUS POWER HANDLING** Maximum continuous input voltage (and the equivalent power rating, in watts, at the stated nominal impedance) that the system can withstand, without damage, for a period of 2 hours using an EIA-426-B defined spectrum; with recommended signal processing and protection filters.
- NOMINAL SENSITIVITY** Averaged SPL over the operating range with an input voltage that would produce 1 Watt at the nominal impedance and the averaged SPL over the operating range with a fixed input voltage of 2.83V, respectively; swept sine wave axial measurements with no external processing applied in whole space, except where indicated.
- NOMINAL MAXIMUM SPL** Calculated based on nominal / peak power handling, respectively, and nominal sensitivity; exclusive of power compression.
- EQUALIZED SENSITIVITY** The respective SPL levels produced when an EIA-426-B signal is applied to the equalized loudspeaker system at a level which produces a total power of 1 Watt, in sum, to the loudspeaker subsections and also at a level which produces a total voltage, in sum, of 2.83V to the loudspeaker subsections, respectively; each referenced to a distance of 1 meter.
- EQUALIZED MAXIMUM SPL** The SPL produced when an EIA-426-B signal is applied to the equalized loudspeaker system, at a level which drives at least one subsection to its rated continuous input voltage limit, referenced to a distance of 1 meter. The peak SPL represents the 2:1 (6dB) crest factor of the EIA-426-B test signal.
- AXIAL PROCESSED RESPONSE** The on-axis variation in acoustic output level with frequency of the complete loudspeaker system with recommended signal processing applied. 1/6 octave Gaussian smoothing applied.
- AXIAL SENSITIVITY** The on-axis variation in acoustic output level with frequency for a 1 Watt swept sine wave, referenced to 1 meter with no signal processing. 1/6 octave Gaussian smoothing applied.
- HORIZONTAL / VERTICAL OFF-AXIS RESPONSES** The loudspeaker's magnitude response at various angles off-axis, with recommended signal processing applied in the operating mode which utilizes the largest number of individually amplified pass bands. 1/6 octave Gaussian smoothing applied.
- DIRECTIVITY INDEX** The ratio of the on-axis SPL squared to the mean squared SPL at the same distance for all points within the measurement sphere for each given frequency; expressed in dB. 1/6 octave Gaussian smoothing applied.
- BEAMWIDTH** The angle between the -6dB points in the polar response of the loudspeaker when driven in the operating mode which utilizes the largest number of individually amplified pass bands. 1/6 octave Gaussian smoothing applied.

Data presented on this spec sheet represents a selection of the basic performance specifications for the model. These specifications are intended to allow the user to perform a fair, straightforward evaluation and comparison with other loudspeaker spec sheets. For a detailed analysis of this loudspeaker's performance, please download the GLL file and/or the CLF file from our website: communitypro.com