



# ELAR EXTQW FLOOD HP™

user manual

©2015 **ELATION PROFESSIONAL** all rights reserved. Information, specifications, diagrams, images, and instructions herein are subject to change without notice. ELATION PROFESSIONAL logo and identifying product names and numbers herein are trademarks of ELATION PROFESSIONAL. Copyright protection claimed includes all forms and matters of copyrightable materials and information now allowed by statutory or judicial law or hereinafter granted. Product names used in this document may be trademarks or registered trademarks of their respective companies and are hereby acknowledged. All non-ELATION brands and product names are trademarks or registered trademarks of their respective companies.

**ELATION PROFESSIONAL** and all affiliated companies hereby disclaim any and all liabilities for property, equipment, building, and electrical damages, injuries to any persons, and direct or indirect economic loss associated with the use or reliance of any information contained within this document, and/or as a result of the improper, unsafe, insufficient and negligent assembly, installation, rigging, and operation of this product.

**Elation Professional USA** | 6122 S. Eastern Ave. | Los Angeles, CA. 90040  
323-582-3322 | 323-832-9142 fax | [www.elationlighting.com](http://www.elationlighting.com) | [info@elationlighting.com](mailto:info@elationlighting.com)

**Elation Professional B.V.** | Junostraat 2 | 6468 EW Kerkrade, Netherlands  
+31 45 546 85 66 | +31 45 546 85 96 fax | [www.elationlighting.eu](http://www.elationlighting.eu) | [info@elationlighting.eu](mailto:info@elationlighting.eu)

## DOCUMENT VERSION

 Please check [www.elationlighting.com](http://www.elationlighting.com) for the latest revision/update of this manual.

| Date   | Document Version | DMX Channel Modes             | Notes                  |
|--------|------------------|-------------------------------|------------------------|
| 1/2015 | 2                | 1 / 2 / 3 / 4 / 5 / 6 / 7 / 8 | Updated manual format. |

## CONTENTS

|                                  |    |
|----------------------------------|----|
| General Information              | 4  |
| Warranty                         | 7  |
| Safety Instructions              | 8  |
| General Guidelines               | 9  |
| Fixture Installation             | 10 |
| Understanding DMX                | 13 |
| Fixture Control                  | 16 |
| DMX Channel Functions And Values | 20 |
| Cleaning and Maintenance         | 23 |
| Technical Specifications         | 24 |
| Optional Accessories             | 26 |

## GENERAL INFORMATION

### INTRODUCTION

Congratulations, you have just purchased one of the most innovative and reliable ArtNet to DMX converter on the market today! The **ELAR EXTQW FLOOD HP™** has been designed to perform reliably for years when the guidelines in this booklet are followed. Please read and understand the instructions in this manual carefully and thoroughly before attempting to operate this unit. These instructions contain important information regarding safety during use and maintenance.



### IP65 RATED

An IP rated lighting fixture is one, which is commonly installed in outdoor environments and has been designed with an enclosure that effectively protects the ingress (entry) of external foreign objects such as dust and water. The **International Protection (IP)** rating system is commonly expressed as "IP" (Ingress Protection) followed by two numbers (i.e. IP65) where the numbers define the degree of protection. The first digit (Foreign Bodies Protection) indicates the extent of protection against particles entering the fixture and the second digit (Water Protection) indicates the extent of protection against water entering the fixture. An IP65 rated lighting fixture is one, which has been designed and tested to protect against the ingress of dust (6) and high-pressure water jets from any direction (5).



### **MARINE/COASTAL ENVIRONMENT INSTALLATIONS!**

Please note although this fixture is IP rated, the fixture is **NOT** suitable for marine and/or coastal environment installations. Installing this fixture in a marine and/or coastal environment may cause corrosion and/or excessive wear to the interior and/or exterior components of the fixture. Damages and/or performance issues resulting from installation in a marine and/or coastal environment will void the manufactures warranty and will **NOT** be subject to any warranty claims and/or repairs.



Ensure **ALL** connections and end caps are properly sealed with a non-conductive dielectric grease (available at most electrical suppliers) to prevent water ingress/condensation and/or corrosion.



### **OPTIONAL CORROSION-RESISTANT COATING**

Optional Corrosion-Resistant Coatings may be available for this fixture. Please consult your **Elation Professional** sales representative for details.

## UNPACKING

Thank you for purchasing the **ELAR EXTQW FLOOD HP™** by Elation Professional®. Every **ELAR EXTQW FLOOD HP™** has been thoroughly tested and has been shipped in perfect operating condition. Carefully check the shipping carton for damage that may have occurred during shipping. If the carton appears to be damaged, carefully inspect your unit for damage and be sure all accessories necessary to operate the unit have arrived intact. In the event damage has been found or parts are missing, please contact our customer support team for further instructions. Please do not return this unit to your dealer without first contacting customer support at the number listed below. Please do not discard the shipping carton in the trash. Please recycle whenever possible.

## BOX CONTENTS

- (1) 4pin Female to Edison Power Cable 8 ft. (2.4m)
- (1) 3pin Male XLR to 3pin Female DMX Cable 6.6 ft. (2m)
- (1) 3pin Female XLR to 3pin Male DMX Cable 6.6 ft. (2m)
- (1) Bag of DMX End Caps
- Manual & Warranty Card

## CUSTOMER SUPPORT

Elation Professional® provides a customer support line, to provide set up help and to answer any question should you encounter problems during your set up or initial operation. You may also visit us on the web at [www.elationlighting.com](http://www.elationlighting.com) for any comments or suggestions. For service related issue please contact Elation Professional®.

### **ELATION SERVICE USA - Monday - Friday 8:00am to 5:00pm PST**

**Voice: 323-582-3322**

**Fax: 323-832-9142**

E-mail: [support@elationlighting.com](mailto:support@elationlighting.com)

### **ELATION SERVICE EUROPE - Monday - Friday 08:30 to 17:00 CET**

**Voice: +31 45 546 85 30**

**Fax: +31 45 546 85 96**

E-mail: [support@elationlighting.eu](mailto:support@elationlighting.eu)

## **WARRANTY REGISTRATION**

Please fill out the enclosed warranty card to validate your purchase. All returned service items whether under warranty or not, must be freight pre-paid and accompany a return authorization (R.A.) number. The R.A. number must be clearly written on the outside of the return package. A brief description of the problem as well as the R.A. number must also be written down on a piece of paper and included in the shipping container. If the unit is under warranty, you must provide a copy of your proof of purchase invoice. Items returned without a R.A. number clearly marked on the outside of the package will be refused and returned at customer's expense. You may obtain a R.A. number by contacting customer support at 323-582-3322.

### **IMPORTANT NOTICE!**



**There are no user serviceable parts inside this unit. Do not attempt any repairs yourself; doing so will void your manufactures warranty. Damages resulting from modifications to this fixture and/or the disregard of safety and general user instructions found in this user manual void the manufactures warranty and are not subject to any warranty claims and/or repairs.**

## LIMITED WARRANTY

A. Elation Professional® hereby warrants, to the original purchaser, Elation Professional® products to be free of manufacturing defects in material and workmanship for a period of two years (730 days), and Elation Professional® product rechargeable batteries to be free of manufacturing defects in material and workmanship for a period of six months (180 days), from the original date of purchase. This warranty excludes discharge lamps and all product accessories. This warranty shall be valid only if the product is purchased within the United States of America, including possessions and territories. It is the owner's responsibility to establish the date and place of purchase by acceptable evidence, at the time service is sought.

B. For warranty service, send the product only to the Elation Professional® factory. All shipping charges must be pre-paid. If the requested repairs or service (including parts replacement) are within the terms of this warranty, Elation Professional® will pay return shipping charges only to a designated point within the United States. If any product is sent, it must be shipped in its original package and packaging material. No accessories should be shipped with the product. If any accessories are shipped with the product, Elation Professional® shall have no liability what so ever for loss and/or or damage to any such accessories, nor for the safe return thereof.

C. This warranty is void if the product serial number and/or labels are altered or removed; if the product is modified in any manner which Elation Professional® concludes, after inspection, affects the reliability of the product; if the product has been repaired or serviced by anyone other than the Elation Professional® factory unless prior written authorization was issued to purchaser by Elation Professional®; if the product is damaged because not properly maintained as set forth in the product instructions, guidelines and/or user manual.

D. This is not a service contract, and this warranty does not include any maintenance, cleaning or periodic check-up. During the periods as specified above, Elation Professional® will replace defective parts at its expense, and will absorb all expenses for warranty service and repair labor by reason of defects in material or workmanship. The sole responsibility of Elation Professional® under this warranty shall be limited to the repair of the product, or replacement thereof, including parts, at the sole discretion of Elation Professional®. All products covered by this warranty were manufactured after January 1, 1990, and bare identifying marks to that effect.

E. Elation Professional® reserves the right to make changes in design and/or performance improvements upon its products without any obligation to include these changes in any products theretofore manufactured.

F. No warranty, whether expressed or implied, is given or made with respect to any accessory supplied with the products described above. Except to the extent prohibited by applicable law, all implied warranties made by Elation Professional® in connection with this product, including warranties of merchantability or fitness, are limited in duration to the warranty periods set forth above. And no warranties, whether expressed or implied, including warranties of merchantability or fitness, shall apply to this product after said periods have expired. The consumer's and/or dealer's sole remedy shall be such repair or replacement as is expressly provided above; and under no circumstances shall Elation Professional® be liable for any loss and/or damage, direct and/or consequential, arising out of the use of, and/or the inability to use, this product.

G. This warranty is the only written warranty applicable to Elation Professional® products and supersedes all prior warranties and written descriptions of warranty terms and conditions heretofore published.

# SAFETY INSTRUCTIONS



The **ELAR EXTQW FLOOD HP™** is an extremely sophisticated piece of electronic equipment. To guarantee a smooth operation, it is important to follow the guidelines in this manual. The manufacturer of this device will not accept responsibility for damages resulting from the misuse of this fixture due to the disregard of the information printed in this manual.



This device falls under **PROTECTION CLASS 1**. It's essential this device be grounded properly. Only qualified personnel should perform all electrical connections.

## C A U T I O N S



**UNPLUG POWER BEFORE SERVICING FIXTURE**



**NEVER TOUCH FIXTURE DURING OPERATION AS IT MAY BE HOT**



**NEVER LOOK DIRECTLY INTO THE LIGHT SOURCE  
SENSITIVE PERSONS MAY SUFFER AN EPILEPTIC SHOCK**

- For proper operation, follow the **Installation** guidelines described in this manual. Only qualified and certified personnel should perform installation of this fixture and only the original rigging parts (brackets) included with this fixture should be used for installation. Any modifications will void the original manufacturer's warranty and increase the risk of damage and/or personal injury.
- Never look directly into the light source of this fixture to prevent risk of injury to your retina, which may induce blindness. Those suffering from **EPILEPSY** should avoid looking directly into the light source of this unit at all times.
- Always disconnect from main power source before performing any type of service and/or cleaning procedure. Only handle the power cord by the plug end, never pull out the plug by tugging the wire portion of the cord.
- Do not operate this fixture if the power cord has become frayed, crimped and/or damaged. If the power cord is damaged, replace it immediately with a new one of similar power rating.



## GENERAL GUIDELINES



- **NEVER OPEN THIS FIXTURE WHILE IN USE!**
- **Ensure ALL connections and end caps are properly sealed with a dielectric grease (available at most electrical suppliers) to prevent water corrosion and/or electrical short circuit.**
- During the initial operation of this fixture, a light smoke or smell may emit from the interior of the fixture. This is a normal process and is caused by excess paint in the interior of the casing burning off from the heat associated with the lamp and will decrease gradually over time.
- Please make sure there are **NO FLAMMABLE MATERIALS** close to the fixture while operating, to prevent any fire hazard.
- **Minimum** distance of inflammable materials from the surface **1.6 feet (0.5m)**.
- **DO NOT** attempt installation and/or operation without knowledge how to do so.
- **DO NOT** allow operation by persons who are not qualified to operate this type of fixture. Most damages are the result of operations by nonprofessionals.
- Consistent operational breaks may ensure the fixture will function properly for many years to come.
- **DO NOT** shake fixture, avoid brute force when installing and/or operating fixture.
- Always install the fixture with an appropriate safety cable. When installing the fixture in a suspended environment, always use mounting hardware that is no less than M10 x 25 mm, also be sure the hardware is insert in the pre-arranged screw holes in the bracket of the fixture.
- Use the original packaging and materials to transport the fixture in for service.
- **DO NOT TOUCH** the housing bare-hand during its operation. Turn OFF the power and allow approximately 15 minutes for the fixture to cool down before replacing or serving.

## FIXTURE INSTALLATION



### **FLAMMABLE MATERIAL WARNING**

Keep fixture at least 5.0 ft (1.5m) away from any flammable materials, decorations, pyrotechnics, etc.



### **ELECTRICAL CONNECTIONS**

A qualified electrician should be used for all electrical connections and/or installations.

## CAUTIONS

- For added protection, mount the fixture in areas outside walking paths, seating areas, or in areas where unauthorized personnel might reach the fixture.
- Min/Max ambient operating temperature for this fixture is **5°F to 113°F (-15°C to 45°C)**. Do not use the fixture under or above this temperature.
- Before mounting the fixture to any surface, make sure the installation area can hold a minimum point load of 10 times the weight of the fixture. **99 lbs / 45 kg**
- Fixture installation must always be secured with a secondary safety attachment, such as an appropriate safety cable.
- Never stand directly below the device when mounting, removing or servicing.

- **Ensure ALL connections and end caps are properly sealed with a dielectric grease (available at most electrical suppliers) to prevent water corrosion and/or electrical short circuit.**

## POWER LINKING

Max number of units that can be power linked is **10 units @110V** and **20 units @240V**.

## CLAMP MOUNTING

The **ELAR EXTQW FLOOD HP™** provides a unique integrated mounting Yoke. When mounting this fixture to truss be sure to secure an appropriately rated clamp using an M10 screw fitted through the center hole of the mounting Yoke.

## MOUNTING POINTS

- Overhead mounting requires extensive experience, including amongst others calculating working load limits, installation material being used, and periodic safety inspection of all installation material and the device. If you lack these qualifications, do not attempt the installation yourself. Improper installation can result in bodily injury.
- Fixture is fully operational in the specific mounting positions as illustrated below.

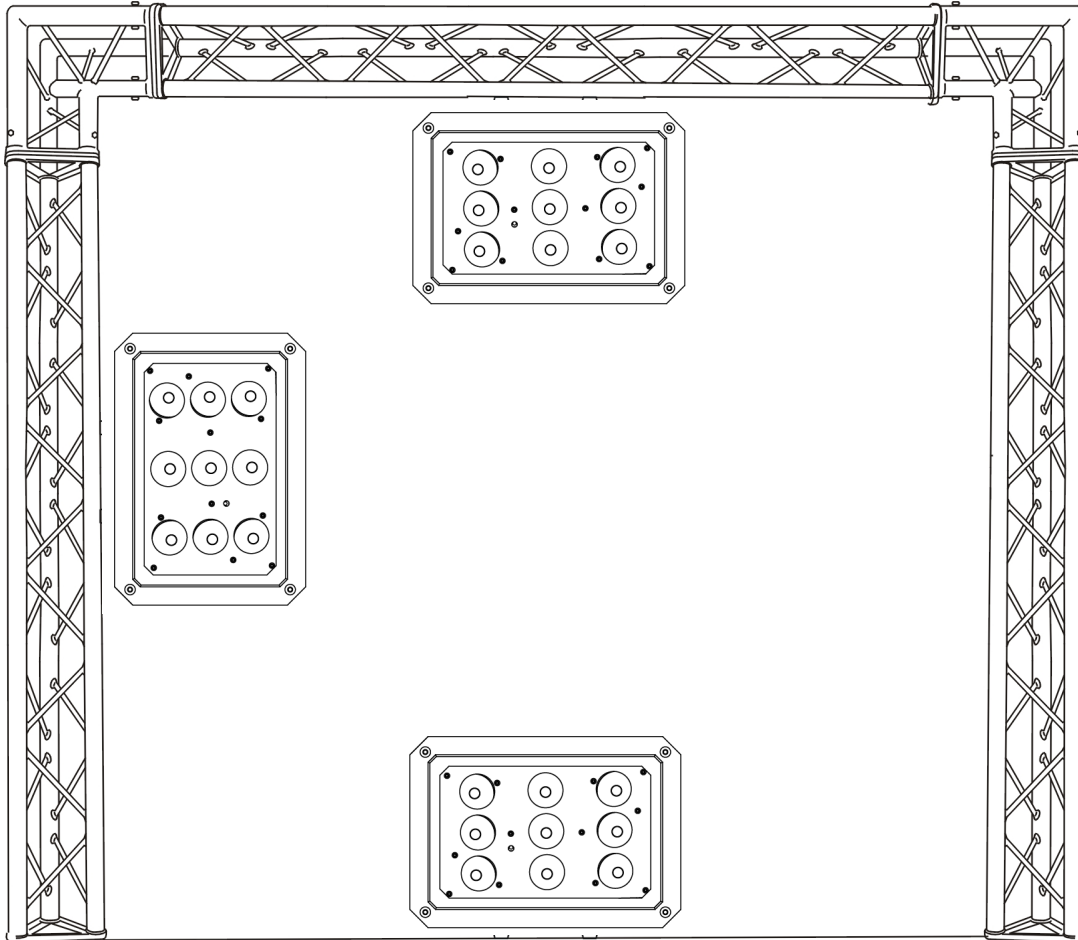

## SAFETY CABLE

**Always use a Safety Cable whenever installing this fixture in a suspended environment to ensure the fixture will not drop if the clamp fails.**

## SECURING

Regardless of the rigging option you choose for your **ELAR EXTQW FLOOD HP™** always be sure to secure your fixture with a safety cable.

### SAFETY CABLE RIGGING POINT

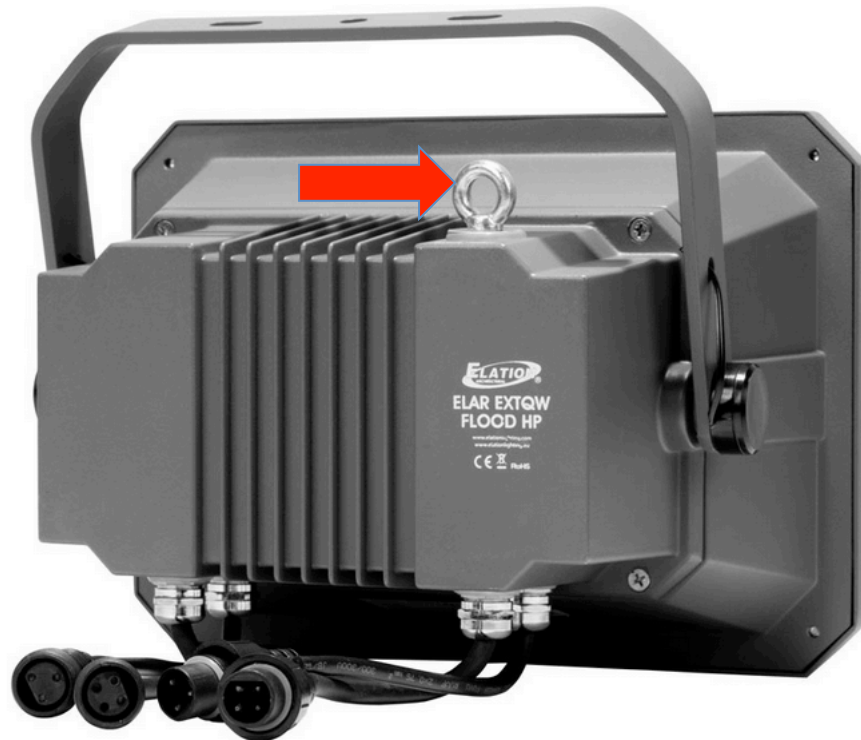

## UNDERSTANDING DMX

### DMX-512

DMX is short for Digital Multiplex. This is a universal protocol used by most lighting and controller manufactures as a form of communication between intelligent fixtures and controllers. DMX allows all makes and models of different manufactures to be linked together and operate from a single controller. This is possible as long as all the fixtures and the controller are DMX compliant. A DMX controller sends the DMX data instructions to the fixture allowing the user to control the different aspects of an intelligent light. DMX data is sent out as serial data that travels from fixture to fixture via data "IN" and data "OUT" XLR terminals located on the fixtures (most controllers will only have output jacks).

### DMX LINKING

To ensure proper DMX data transmission, always use the included **ELAR™** series IP rated DMX cables listed in the **OPTIONAL ACCESSORIES** section at the end of this manual. When using several DMX fixtures try to use the shortest cable path possible. Never split a DMX line with a "Y" style connector. The order in which the fixtures are connected in a DMX line does not influence the DMX addressing. For example; a fixture assigned a starting DMX address of 1 may be placed anywhere in the DMX chain, at the beginning, at the end, or anywhere in the middle. The DMX controller knows to send data assigned to address 1 to that fixture no matter where it is located in the DMX chain. The **ELAR EXTQW FLOOD HP™** can be controlled via DMX-512 protocol and the DMX address is set via the control menu.

### DATA CABLE (DMX Cable) REQUIREMENTS (For DMX and Master/Slave Operation)

Your fixture and your DMX controller require a standard 3pin or 5pin XLR connector for data input and data output (see figure below). Also, remember that a DMX line must be daisy chained and cannot be split.

### DMX-512 CONTROLLER CONNECTION

Connect the provided XLR cable to the female XLR output of your controller and the other side to the male XLR input of the **ELAR EXTQW FLOOD HP™**. The diagram below illustrates a typical DMX-512 connection when the fixture is in the **8 Channel Mode**. You can chain multiple panels together through serial linking. Always be sure daisy chain your in and out data connections, never split or “Y” your DMX connections.

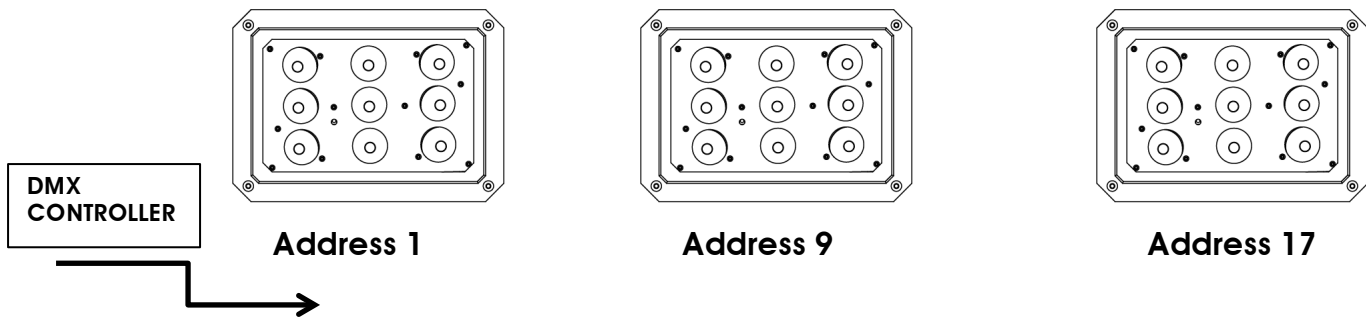

### DMX-512 CONNECTION WITH DMX TERMINATOR

A DMX terminator should be used in all DMX lines especially in longer runs. The use of a terminator may avoid erratic behavior in your DMX line. A terminator is a 120 ohm 1/4 watt resistor that is connected between pins 2 and 3 of a male XLR connector (DATA + and DATA -). This fixture is inserted in the female XLR connector of the last fixture in your daisy chain to terminate the line. Using a line terminator will decrease the possibilities of erratic behavior. Use the included **ELAR™ DMX Terminator End Caps**.

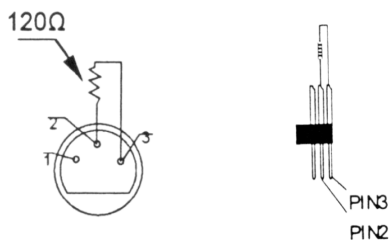

Termination reduces signal errors and avoids signal transmission problems and interference. It is always advisable to connect a DMX terminal, (Resistance 120 Ohm 1/4 W) between PIN 2 (DMX-) and PIN 3 (DMX +) of the last fixture.

## DMX ADDRESSING

All fixtures should be given a DMX starting address when using a DMX controller, so the correct fixture responds to the correct control signal. This digital starting address is the channel number from which the fixture starts to “listen” to the digital control information sent out from the DMX controller. The allocation of this starting DMX address is achieved by setting the correct DMX address on the digital display located on the back of the fixture.

You can set the same starting address for all fixtures or a group of fixtures, or set different address for each individual fixture. Be advised that setting all fixtures to the same DMX address will subsequently control all fixtures in the same fashion, in other words, changing the settings of one channel will affect all the fixtures simultaneously.

If you set each fixture to a different DMX address, each unit will start to “listen” to the channel number you have set, based on the quantity of control channels (DMX channels) of each fixture. That means changing the settings of one channel will only affect the selected fixture.

In the case of the **ELAR EXTQW FLOOD HP™**, when in the **12 Channel Mode** you should set the starting DMX address of the first unit to 1, the second unit to 9 (1 + 8), the third unit to 17 (9 + 8), and so on.

**Note:** During start-up the **ELAR EXTQW FLOOD HP™** will automatically detect whether a DMX data signal is being received or not. If the fixture is not receiving a DMX signal please check the following:

- The 3pin or 5pin XLR input plug (cable with DMX signal from controller) is not connected or is not inserted completely into the DMX input jack of the fixture.
- The DMX controller is switched off or defective.
- The DMX cable or connector is defective.
- A DMX terminator has been inserted into the last fixture in your DMX chain.

# FIXTURE CONTROL

## ON-BOARD SYSTEM MENU

The **ELAR EXTQW FLOOD HP™** requires the **ELAR WR II™** Infrared Wireless Remote Controller (pictured below) to make any menu/mode changes to the fixture. This remote is an optional accessory and is **NOT INCLUDED**.

The next sections will cover how to access each menu/mode function.



**ELAR WR II™**



### REMOTE CONTROL USE

Must be aimed towards front face of the fixture within a max distance of **32 ft (10m)**.



## PROGRAM MODE

Press **PROG** button to cycle through the following modes: **COLOR SELECT MODE**, **AUTO RUN MODE**, **COLOR FADE MODE**, and **COLOR CHANGE MODE**. Each press of the **PROG** button will change to the next mode in order.

### COLOR SELECT MODE

When all the LEDs glow **RED** for a short period of time, this indicates that the fixture is now in the **STATIC COLOR SELECT MODE**. You can press the “+” and “-” buttons or press two numbers **00-15** to select one of the 16 static colors. (See color chart below) You can also press the **FLASH** button to turn the flash **ON/OFF** and press the “+” and “-” buttons or press two numbers **00-15** to adjust the flash speed:

**00 = OFF, 01 = SLOWEST SPEED, 15 = FASTEST SPEED.**

|                            |
|----------------------------|
| Off                        |
| Red                        |
| Green                      |
| Blue                       |
| White                      |
| Red + Green                |
| Red + Blue                 |
| Red + White                |
| Green + Blue               |
| Green + White              |
| Blue + White               |
| Red + Green + Blue         |
| Red + Green + White        |
| Red + Blue + White         |
| Green + Blue + White       |
| Red + Green + Blue + White |

### AUTO RUN MODE

When all the LEDs glow **GREEN** for a short period of time, this indicates that the fixture is now in the **AUTO RUN MODE**. You can also press the **SPEED** button to enter **SPEED SET MODE** and press the “+” and “-” buttons or press two numbers **01-16** to adjust the auto run speed:

**SPEED, 01 = SLOWEST SPEED, 16 = FASTEST SPEED.**

## COLOR FADE MODE

When all of the LEDs glow **BLUE** for a short period of time, this indicates that the fixture is now in the **COLOR FADE MODE**. You can press the “+” and “-” buttons or press two numbers **01-16** to select the **COLOR FADE MODE**. You can also press **SPEED** button to enter the **SPEED SET MODE** and press the “+” and “-” buttons or press in two numbers **01-16** to adjust the color fade speed:

**01 = SLOWEST SPEED, 16 = FASTEST SPEED.**

## COLOR CHANGE MODE

When all of the LEDs glow **WHITE** for a short period of time, this indicates that the fixture is now in the **COLOR CHANGE MODE**. You can press the “+” and “-” buttons or press two numbers **01-16** to select one of the **16 COLOR CHANGE MODES**. You can also press the **SPEED** button to enter **SPEED SET MODE** and press the “+” and “-” buttons or press two numbers **01-16** to adjust the color change speed:

**01 = SLOWEST SPEED, 16 = FASTEST SPEED.**

## M/S MODE

Press the **SL/SA** button to select **SLAVE MODE** to control the fixture by the master unit.

## LIGHT PROGRAM MODE

Press the **R/G/B/W** buttons to choose Red/Green/Blue/White colors and the press the “+” and “-” buttons or press three number **000-255** to adjust the intensity of each LED color. You can also press the **FLASH** button to turn **ON** flash and press the “+” and “-” buttons or press two numbers **00-15** to adjust the flash speed:

**00 = OFF, 01 = SLOWEST SPEED, 15 = FASTEST SPEED.**

## DMX MODE

There are (8) different DMX modes. You must set the DMX Channel mode before you can address the fixture. To select your desired DMX Channel mode press the **DMX MODE** button, and then press the “+” or “-” buttons to scroll through the DMX Channel modes in the order they are listed below. Once the desired DMX Channel mode is selected, set the desired DMX address.

- **RED** LEDs glow = **DMX Mode 1: 1 DMX Channel**
- **GREEN** LEDs glow = **DMX Mode 2: 2 DMX Channels**
- **BLUE** LEDs glow = **DMX Mode 3: 3 DMX Channels**
- **WHITE** LEDs glow = **DMX Mode 4: 4 DMX Channels**
- **RED** and **GREEN** LEDs glow = **DMX Mode 5: 5 DMX Channels**
- **RED** and **BLUE** LEDs glow = **DMX Mode 6: 6 DMX Channels**
- **RED** and **WHITE** LEDs glow = **DMX Mode 7: 7 DMX Channels**
- **GREEN** and **BLUE** LEDs glow = **DMX Mode 8: 8 DMX Channels**

## SET DMX ADDRESS

Press the **SET ADDR** button to set the 3-digit DMX address or initialize the program, the LEDs will then flash **RED**, **GREEN**, **BLUE** and **WHITE** 2~3 times. After the LEDs glow **RED**, press the first number of the DMX address. After the first number is entered the LEDs will glow **GREEN**, then press the second number of the DMX address. After the second number is entered the LEDs will glow **BLUE**, then press the third number of the DMX address. After all three numbers of the DMX address are entered, the LEDs will flash **RED**, then **GREEN**, then **BLUE**, and finally **WHITE** 2~3 times, which indicates the DMX address has been entered correctly and the fixture is now in **DMX MODE**.

If the DMX address was entered incorrectly, the LEDs will glow **RED** and a new DMX address must be entered.

## BLACK OUT MODE

Press the “**BLACK OUT**” button to turn all the LEDs **ON/OFF**, like a shutter.

# DMX CHANNEL FUNCTIONS AND VALUES

## DMX Mode 1: 1 Channel Mode

| Value   | Function                   |
|---------|----------------------------|
| 000-015 | Off                        |
| 016-031 | Red                        |
| 032-047 | Green                      |
| 048-063 | Blue                       |
| 064-079 | White                      |
| 080-095 | Red + Green                |
| 096-111 | Red + Blue                 |
| 112-127 | Red + White                |
| 128-143 | Green + Blue               |
| 144-159 | Green + White              |
| 160-175 | Blue + White               |
| 176-191 | Red + Green + Blue         |
| 192-207 | Red + Green + White        |
| 208-223 | Red + Blue + White         |
| 224-239 | Green + Blue + White       |
| 240-255 | Red + Green + Blue + White |

## DMX Mode 2: 2 Channel Mode

| Channel | Value                                | Function                |
|---------|--------------------------------------|-------------------------|
| 1       | STATIC COLOR MACROS (See DMX Mode 1) |                         |
| 2       | 0 - 255                              | MASTER DIMMER 0% - 100% |

## DMX Mode 3: 3 Channel Mode

| Channel | Value                                | Function                             |
|---------|--------------------------------------|--------------------------------------|
| 1       | STATIC COLOR MACROS (See DMX Mode 1) |                                      |
| 2       | 0 - 255                              | MASTER DIMMER 0% - 100%              |
| 3       | 0-15<br>16-255                       | STROBING OFF<br>STROBING SLOW - FAST |

## DMX Mode 4: 4 Channel Mode

| Channel | Value | Function        |
|---------|-------|-----------------|
| 1       | 0-255 | RED 0% - 100%   |
| 2       | 0-255 | GREEN 0% - 100% |
| 3       | 0-255 | BLUE 0% - 100%  |
| 4       | 0-255 | WHITE 0% - 100% |

**DMX Mode 5: 5 Channel Mode**

| Channel | Value | Function                |
|---------|-------|-------------------------|
| 1       | 0-255 | RED 0% - 100%           |
| 2       | 0-255 | GREEN 0% - 100%         |
| 3       | 0-255 | BLUE 0% - 100%          |
| 4       | 0-255 | WHITE 0% - 100%         |
| 5       | 0-255 | MASTER DIMMER 0% - 100% |

**DMX Mode 6: 6 Channel Mode**

| Channel | Value                                | Function                |
|---------|--------------------------------------|-------------------------|
| 1       | 0-255                                | RED 0% - 100%           |
| 2       | 0-255                                | GREEN 0% - 100%         |
| 3       | 0-255                                | BLUE 0% - 100%          |
| 4       | 0-255                                | WHITE 0% - 100%         |
| 5       | 0-255                                | MASTER DIMMER 0% - 100% |
| 6       | STATIC COLOR MACROS (See DMX Mode 1) |                         |

**Note: Channel 1, 2 and 3 will not work, when Channel 6 is being used.**

**DMX Mode 7: 7 Channel Mode**

| Channel | Value                                | Function                             |
|---------|--------------------------------------|--------------------------------------|
| 1       | 0-255                                | RED 0% - 100%                        |
| 2       | 0-255                                | GREEN 0% - 100%                      |
| 3       | 0-255                                | BLUE 0% - 100%                       |
| 4       | 0-255                                | WHITE 0% - 100%                      |
| 5       | 0-255                                | MASTER DIMMER 0% - 100%              |
| 6       | 0-15<br>16-255                       | STROBING OFF<br>STROBING SLOW - FAST |
| 7       | STATIC COLOR MACROS (See DMX Mode 1) |                                      |

**Note: Channel 1, 2 and 3 will not work, when Channel 7 is being used.**

### DMX Mode 8: 8 Channels Mode

| CH8       |                               | CH7                            | CH6                     | CH5                                | CH4                           | CH3                          | CH2                           | CH1                         |
|-----------|-------------------------------|--------------------------------|-------------------------|------------------------------------|-------------------------------|------------------------------|-------------------------------|-----------------------------|
| DMX VALUE | FUNCTION                      |                                |                         |                                    |                               |                              |                               |                             |
| 0-255     | NO FUNCTION                   | DIMMER MODE (0-63)             | STROBE MODE<br>(16-255) |                                    | WHITE (0-255)<br>(Dim→Bright) | BLUE (0-255)<br>(Dim→Bright) | GREEN (0-255)<br>(Dim→Bright) | RED (0-255)<br>(Dim→Bright) |
| 0-255     | COLOR MACROS (See DMX Mode 1) | STATIC COLOR MODE (64-127)     |                         |                                    |                               |                              |                               |                             |
| 000-015   | COLOR CHASE 1                 | COLOR CHASE MODES<br>(128-191) | SPEED MODE<br>(0-255)   | DIMMING<br>(0-255)<br>(Dim→Bright) | No Function                   | No Function                  | No Function                   | No Function                 |
| 016-031   | COLOR CHASE 2                 |                                |                         |                                    |                               |                              |                               |                             |
| 032-047   | COLOR CHASE 3                 |                                |                         |                                    |                               |                              |                               |                             |
| 048-063   | COLOR CHASE 4                 |                                |                         |                                    |                               |                              |                               |                             |
| 064-079   | COLOR CHASE 5                 |                                |                         |                                    |                               |                              |                               |                             |
| 080-095   | COLOR CHASE 6                 |                                |                         |                                    |                               |                              |                               |                             |
| 096-111   | COLOR CHASE 7                 |                                |                         |                                    |                               |                              |                               |                             |
| 112-127   | COLOR CHASE 8                 |                                |                         |                                    |                               |                              |                               |                             |
| 128-143   | COLOR CHASE 9                 |                                |                         |                                    |                               |                              |                               |                             |
| 144-159   | COLOR CHASE 10                |                                |                         |                                    |                               |                              |                               |                             |
| 160-175   | COLOR CHASE 11                |                                |                         |                                    |                               |                              |                               |                             |
| 176-191   | COLOR CHASE 12                |                                |                         |                                    |                               |                              |                               |                             |
| 192-207   | COLOR CHASE 13                |                                |                         |                                    |                               |                              |                               |                             |
| 208-223   | COLOR CHASE 14                |                                |                         |                                    |                               |                              |                               |                             |
| 224-239   | COLOR CHASE 15                |                                |                         |                                    |                               |                              |                               |                             |
| 240-255   | COLOR CHASE 16                |                                |                         |                                    |                               |                              |                               |                             |
| 000-015   | COLOR FADE 1                  | COLOR FADE MODES<br>(192-255)  | (Slow→Fast)             |                                    |                               |                              |                               |                             |
| 016-031   | COLOR FADE 2                  |                                |                         |                                    |                               |                              |                               |                             |
| 032-047   | COLOR FADE 3                  |                                |                         |                                    |                               |                              |                               |                             |
| 048-063   | COLOR FADE 4                  |                                |                         |                                    |                               |                              |                               |                             |
| 064-079   | COLOR FADE 5                  |                                |                         |                                    |                               |                              |                               |                             |
| 080-095   | COLOR FADE 6                  |                                |                         |                                    |                               |                              |                               |                             |
| 096-111   | COLOR FADE 7                  |                                |                         |                                    |                               |                              |                               |                             |
| 112-127   | COLOR FADE 8                  |                                |                         |                                    |                               |                              |                               |                             |
| 128-143   | COLOR FADE 9                  |                                |                         |                                    |                               |                              |                               |                             |
| 144-159   | COLOR FADE 10                 |                                |                         |                                    |                               |                              |                               |                             |
| 160-175   | COLOR FADE 11                 |                                |                         |                                    |                               |                              |                               |                             |
| 176-191   | COLOR FADE 12                 |                                |                         |                                    |                               |                              |                               |                             |
| 192-207   | COLOR FADE 13                 |                                |                         |                                    |                               |                              |                               |                             |
| 208-223   | COLOR FADE 14                 |                                |                         |                                    |                               |                              |                               |                             |
| 224-239   | COLOR FADE 15                 |                                |                         |                                    |                               |                              |                               |                             |
| 240-255   | COLOR FADE 16                 |                                |                         |                                    |                               |                              |                               |                             |

**NOTES:**

- ① When Channel 7 fader level is between values of (0 and 63), Channel 1 to Channel 4 will control the Red/Green/Blue/White dimmer, and Channel 6 will control strobe speed.
- ② When Channel 7 fader level is between values of (64 and 127), Channel 8 fader will select one of the 16 Static COLOR MACROS listed in DMX Mode 1, and Channel 6 will control strobe speed.
- ③ When Channel 7 fader level is between the values of (128 and 191), Channel 8 fader will select one of the 16 COLOR CHASE MODES, and Channel 6 will control COLOR CHASE speed.
- ④ When Channel 7 fader level is between the values of (192 and 255), Channel 8 fader will select one of the 16 COLOR FADE MODES, and Channel 6 will control COLOR FADE speed.

## CLEANING AND MAINTENANCE



**C A U T I O N**

**Disconnect power before cleaning or maintenance.**

### CLEANING

Frequent cleaning is recommended to insure proper function, optimized light output, and an extended life. The frequency of cleaning depends on the environment in which the fixture operates: damp, smoky or particularly dirty environments can cause greater accumulation of dirt on the fixture's optics.

- Clean the external lens surface at least every 20 days with a soft cloth to avoid dirt/debris accumulation. Never use alcohol, solvents, or ammonia based cleaners.

### MAINTENANCE

Regular inspections are recommended to insure proper function and extended life. There are no user serviceable parts inside this fixture, please refer all other service issues to an authorized Elation service technician. Should you need any spare parts, please order genuine parts from your local Elation dealer.

Please refer to the following points during routine inspections:

- A detailed electric check by an approved electrical engineer every 3 months, to make sure the circuit contacts are in good condition and prevent overheating.
- Be sure all screws and fasteners are securely tightened at all times. Loose screws may fall out during normal operation resulting in damage or injury.
- Check for any deformations on the housing, color lenses, rigging hardware and rigging points (ceiling, suspension, trussing). Deformations in the housing could allow for dust to enter into the fixture. Damaged rigging points or unsecured rigging could cause the fixture to fall and seriously injure a person(s).
- Inspect all moving parts and make sure there are no signs of wear and rotate/move without imbalances.
- Electric power supply cables must not show any damage, material fatigue or sediments. Never remove the ground prong from the power cable.

## TECHNICAL SPECIFICATIONS

### FEATURES

IP65 Rated  
25° Beam Angle  
Die-Cast Aluminum Housing / Tempered Glass  
IR Remote Programmable  
Flicker Free Operation for TV and FILM

### SOURCE

9 x 5W QUAD Color (RGBW) LEDs  
50,000 Hour Average Life

### EFFECTS

Color + Variable Strobe Macros  
Electronic Dimming: 0% - 100%

### COLOR

RGBW (Red, Green, Blue, White)

### CONTROL / CONNECTIONS

8 DMX Channel Modes (1/2/3/4/5/6/7/8)  
3pin IP DMX In/Out  
4pin IP Power In/Out  
Power Link Multiple Units (10) at 120V (20) at 240V

### SIZE / WEIGHT

Length: 11.8" (298mm)  
Width: 8.3" (210mm)  
Vertical Height: 9.8" (249mm)  
Weight: 9.9 lbs. (4.5kg)

### ELECTRICAL

AC 100-240V - 50/60Hz  
56W Max Power Consumption

### APPROVALS / RATINGS

CE | IP65\*\*

\*\*Optional Corrosion-Resistant Coating may be available for this fixture. Please consult an Elation sales representative for details.

**Please Note: Specifications and improvements in the design of this unit and this manual are subject to change without any prior written notice.**



### PHOTOMETRIC DATA

|            |                   |                   |                   |                  |                 |
|------------|-------------------|-------------------|-------------------|------------------|-----------------|
| RED LEDs   | 196 FC / 2110 LUX | 76 FC / 822 LUX   | 37 FC / 398 LUX   | 22 FC / 237 LUX  | 14 FC / 153 LUX |
| GREEN LEDs | 221 FC / 2380 LUX | 884 FC / 884 LUX  | 39 FC / 421 LUX   | 22 FC / 240 LUX  | 14 FC / 155 LUX |
| BLUE LEDs  | 230 FC / 2480 LUX | 91 FC / 981 LUX   | 42 FC / 455 LUX   | 25 FC / 269 LUX  | 16 FC / 168 LUX |
| WHITE LEDs | 305 FC / 3280 LUX | 116 FC / 1244 LUX | 55 FC / 592 LUX   | 33 FC / 350 LUX  | 20 FC / 217 LUX |
| FULL ON    | 920 FC / 9900 LUX | 342 FC / 3680 LUX | 161 FC / 1736 LUX | 94 FC / 1009 LUX | 61 FC / 653 LUX |

LUX x 0.0929 = FC

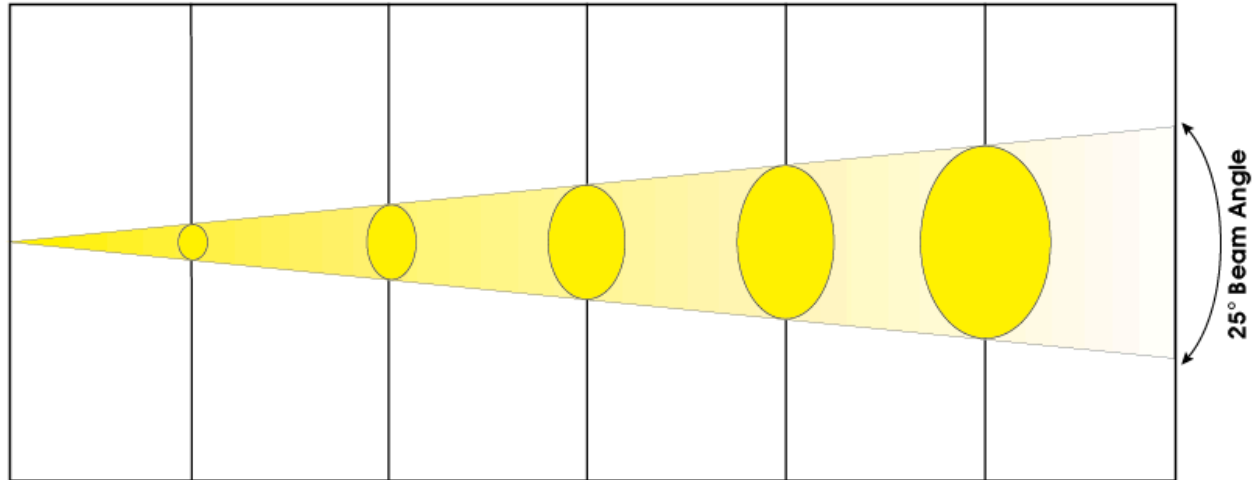

|                          |                     |                     |                     |                     |                     |
|--------------------------|---------------------|---------------------|---------------------|---------------------|---------------------|
| 0 m                      | 1 m                 | 2 m                 | 3 m                 | 4 m                 | 5 m                 |
| 0 ft                     | 3.3 ft              | 6.6 ft              | 9.8 ft              | 13.1 ft             | 16.4 ft             |
| <b>Min Beam Diameter</b> |                     |                     |                     |                     |                     |
| 25° Beam Angle           | ∅ 1.25 m / ∅ 4.1 ft | ∅ 1.35 m / ∅ 4.4 ft | ∅ 1.50 m / ∅ 4.9 ft | ∅ 1.65 m / ∅ 5.4 ft | ∅ 1.80 m / ∅ 5.9 ft |

### DIMENSIONAL DRAWINGS

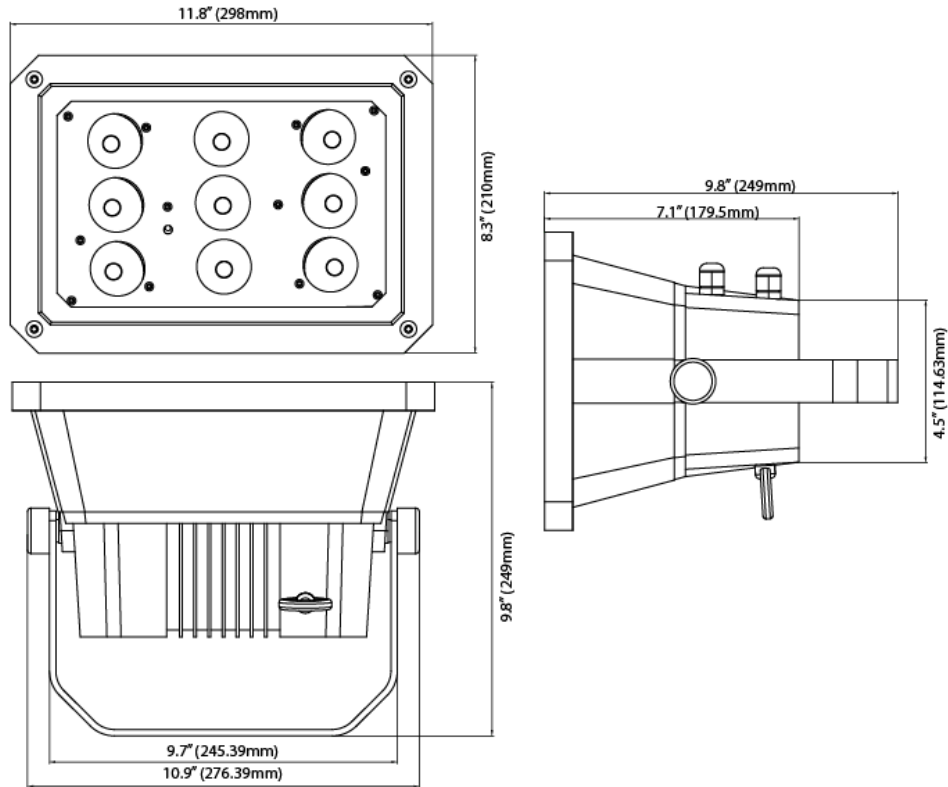

Please Note: Specifications and improvements in the design of this unit and this manual are subject to change without any prior written notice.

## OPTIONAL ACCESSORIES

| ORDER CODE    | ITEM   |
|---------------|--|
| TRIGGER CLAMP | Heavy Duty Wrap Around Hook Style Clamp  |
| ELA958/3MPEC  | 3m (4pin) Power Ext/Link Cable   |
| ELAR 3C-1M    | 1m (3pin) Signal Ext Cable   |
| ELAR 3C-5M    | 5m (3pin) Signal Ext Cable   |
| ELAR WR II    | Infrared Wireless Remote Controller Required To Program Fixture<br><b>*Not Included Purchased Separately</b> |

