

# TOUGH PAR™

# SATELLIGHT

**IP65**

SUITABLE FOR OUTDOOR USE



Blizzard Lighting, LLC  
[www.blizzardlighting.com](http://www.blizzardlighting.com)  
Waukesha, WI USA  
Copyright (c) 2014

# TABLE OF CONTENTS

ToughPar™ Satellight LED Wash Fixture	1
<b>1. Getting Started</b>	<b>3</b>
What's In The Box?	3
Getting It Out Of The Box	3
Powering Up!	3
Getting A Hold Of Us	3
Safety Instructions (Don't Stick Your Hand In The Toaster!)	4
<b>2. Meet The ToughPar™ Satellight</b>	<b>5</b>
Features	5
DMX Quick Reference	5
The ToughPar™ Satellight Pin-up Picture	6
<b>3. Setup</b>	<b>7</b>
Fuse Replacement	7
Connecting A Bunch Of ToughPar™ Satellight PAR Cans	7
Data/DMX Cables	7
Cable Connectors	8
3-Pin??? 5-Pin??? Huh?	8
Take It To The Next Level: Setting up DMX Control	8
Fixture Linking (Master/Slave Mode)	9
Mounting/Rigging	9
<b>4. Operating Adjustments</b>	<b>10</b>
Navigating The Control Panel	10
Control Panel Menu Structure	11
Adjust the Starting DMX Address	12
Slave Mode	12
DMX Channel Mode	12
Built-in Programs	12
DMX Channel Values In-Depth	14
Troubleshooting	15
Dimensional Diagram	16
<b>5. Appendix</b>	<b>17</b>
A Quick DMX Lesson	17
Keeping Your ToughPar™ Satellight As Good As New	18
Returns (Gasp!)	18
Shipping Issues	18
Tech Specs	19

# 1. GETTING STARTED

## What's In The Box?

- 1 x ToughPar™ Satellight Professional LED PAR Fixture
- 1 x IP Rated AC power cord with cable cap
- 1 x Set of IP Rated DMX in/out cables
- This Lovely User Manual

## Optional Accessories (sold separately)

The following accessories are available for this fixture. But the lone wolves that they are, they must be purchased separately. Contact your authorized Blizzard Lighting dealer for pricing!

- DMX-EXT: 3-Meter IP-Rated DMX Extension Cable
- PWR-EXT: 3-Meter IP-Rated Power Extension Cable

## Getting It Out Of The Box

Congratulations on purchasing one of the toughest PAR fixtures anywhere! Now that you've got your ToughPar™ Satellight (or hopefully, *Satellight's!*), you should carefully unpack the box and check the contents to ensure that all parts are present and in good condition. If anything looks as if it has been damaged in transit, notify the shipper immediately and keep the packing material for inspection. Again, please save the carton and all packing materials. If a fixture must be returned to the factory, it is important that the fixture be returned in the original factory box and packing.

## Powering Up!

All fixtures must be powered directly off a switched circuit and **cannot be run off a rheostat (variable resistor) or dimmer circuit, even if the rheostat or dimmer channel is used solely for a 0% to 100% switch.**

*AC Voltage Switch* - Not all fixtures have a voltage select switch, so please verify that the fixture you receive is suitable for your local power supply. See the label on the fixture or refer to the fixture's specifications chart for more information. A fixture's listed current rating is its average current draw under normal conditions. Check the fixture or device carefully to make sure that if a voltage selection switch exists that it is set to the correct line voltage you will use.

**Warning! Verify that the voltage select switch on your unit matches the line voltage applied. Damage to your fixture may result if the line voltage applied does not match the voltage indicated on the voltage selector switch. All fixtures must be connected to circuits with a suitable Ground (Earthing).**

## Getting A Hold Of Us

**If something is wrong, just give us a call or send an email. We'll be happy to help, honest.**

Blizzard Lighting  
N16 W23390 Stoneridge Dr. Ste E  
Waukesha, WI 53188 USA  
www.blizzardlighting.com  
414-395-8365  
Email: support@blizzardlighting.com

**Disclaimer:** The information and specifications contained in this document are subject to change without notice. Blizzard Lighting™ assumes no responsibility or liability for any errors or omissions that may appear in this user manual. Blizzard Lighting™ reserves the right to update the existing document or to create a new document to correct any errors or omissions at any time. You can download the latest version of this document from [www.blizzardlighting.com](http://www.blizzardlighting.com).

Author:	Date:	Last Edited:	Date:
J. Thomas	11/7/2013	J. Thomas	1/31/2014

# SAFETY INSTRUCTIONS



Please read these instructions carefully. They include important information about the installation, usage and maintenance of this product.

- Please keep this User Guide for future use. If you sell the unit to someone else, be sure that they also receive this User Guide.
- ALWAYS make sure that you are connecting to the proper voltage, and that the line voltage you are connecting to is not higher than that stated on the decal or rear panel of the fixture.
- This product is intended for indoor use only.
- To prevent risk of fire or shock, do not expose fixture to rain or moisture.
- Make sure there are no flammable materials close to the unit while operating.
- The unit must be installed in a location with adequate ventilation, at least 20in (50cm) from adjacent surfaces. Be sure that no ventilation slots are blocked.
- ALWAYS disconnect from the power source before servicing or replacing fuse and be sure to replace with same fuse size and type.
- ALWAYS secure fixture using a safety chain. NEVER carry the fixture by its cord. Use its carrying handles.
- DO NOT operate at ambient temperatures higher than 104°F (40°C).
- In the event of a serious operating problem, stop using the unit immediately. NEVER try to repair the unit by yourself. Repairs carried out by unskilled people can lead to damage or malfunction. Please contact the nearest authorized technical assistance center. Always use the same type spare parts.
- NEVER connect the device to a dimmer pack.
- Make sure the power cord is never crimped or damaged.
- Never disconnect the power cord by pulling or tugging on the cord.
- Avoid direct eye exposure to the light source while it is on.

**Caution!** There are no user serviceable parts inside the unit. Do not open the housing or attempt any repairs yourself. In the unlikely event your unit may require service, please contact Blizzard Lighting at support@blizzardlighting.com.

## 2. MEET THE TOUGHPAR™ SATELLIGHT LED PAR

### CONTROL FEATURES

- RGBW color mixing via 9x 10W (4x 2.5w) R/G/B/W 4-in-1 LEDs
- Variable electronic dimming & strobe
- Built-in color & chase macros via DMX
- Built-in automated programs via master/slave
- RGBW color mixing ability in standalone mode
- RGBW w/32-bit dimming (5-Channel), & Extended w/32-bit dimming (9-Channel) DMX Profiles

### ADDITIONAL FEATURES

- Rugged and well-built (It hits the gym regularly)
- 180° tilt head with dual secure locking knobs
- Constant current driver: 320mA
- Flicker-free constant-current 400hz LED driver
- Totally silent convection cooling
- IP Rated AC power cord with cable cap
- IP Rated DMX in/out cables

### DMX Quick Reference: 9-Channel Mode

Channel	What it does...
1	Dimmer
2	Red Intensity (0% <--> 100%)
3	Green Intensity (0% <--> 100%)
4	Blue Intensity (0% <--> 100%)
5	White Intensity (0% <--> 100%)
6	Strobe (slow <--> fast)
7	Static Colors + Color Jump w/Speed Control
8	Auto Color Fade w/Speed Control
9	32-bit Dimmer

### DMX Quick Reference: 5-Channel Mode

Channel	What it does...
1	Red Intensity (0% <--> 100%)
2	Green Intensity (0% <--> 100%)
3	Blue Intensity (0% <--> 100%)
4	White Intensity (0% <--> 100%)
5	32-bit Dimmer

**Figure 1: The ToughPar™ Satellight Pin-Up Picture**



### 3. SETUP



Before replacing a fuse, disconnect power cord. ALWAYS replace with the same type and rating of fuse.

#### Fuse Replacement

**CAUTION!** The ToughPar™ Satellight utilizes a high-output switch-mode power supply with an internal fuse. Under normal operating conditions, the fuse should not require replacement. The fuse is field replaceable, however it is an advanced procedure suited to qualified individuals. Should your ToughPar™ Satellight fuse require replacement, please contact Blizzard Lighting for instructions, or to return your unit for service.

#### Connecting A Bunch of ToughPar™ Satellight Fixtures

You will need a serial data link to run light shows using a DMX-512 controller or to run shows on two or more fixtures set to sync in master/slave operating mode. The combined number of channels required by all the fixtures on a serial data link determines the number of fixtures the data link can support.

Fixtures on a serial data link must be daisy chained in one single line. Also, connecting more than 32 fixtures on one serial data link without the use of a DMX optically-isolated splitter may result in deterioration of the digital DMX signal.

The maximum recommended cable-run distance is 500 meters (1640 ft). The maximum recommended number of fixtures on a serial data link is 32 fixtures.

#### Data/DMX Cabling

To link fixtures together you'll need data cables. You should use data-grade cables that can carry a high quality signal and are less prone to electromagnetic interference.

For instance, Belden© 9841 meets the specifications for EIA RS-485 applications. Standard microphone cables will "probably" be OK, but note that they cannot transmit DMX data as reliably over long distances. In any event, the cable should have the following characteristics:

*2-conductor twisted pair plus a shield*

*Maximum capacitance between conductors – 30 pF/ft.*

*Maximum capacitance between conductor & shield – 55 pF/ft.*

*Maximum resistance of 20 ohms / 1000 ft.*

*Nominal impedance 100 – 140 ohms*

## Cable Connectors

Cables must have a male XLR connector on one end and a female XLR connector on the other end. (Duh!)



**A Word on Termination:** DMX is a resilient communication protocol, however errors still occasionally occur. Termination reduces signal errors, and therefore best practices include use of a terminator in all circumstances. If you are experiencing problems with erratic fixture behavior, especially over long signal cable runs, a terminator may help improve performance.

**To build your own DMX Terminator:**  
Obtain a 120-ohm, 1/4-watt resistor, and wire it between pins 2 & 3 of the last fixture. They are also readily available from specialty retailers.

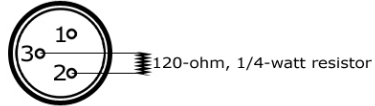

**CAUTION:** Do not allow contact between the common and the fixture's chassis ground. Grounding the common can cause a ground loop, and your fixture may perform erratically. Test cables with an ohm meter to verify correct polarity and to make sure the pins are not grounded or shorted to the shield or each other.

## 3-Pin??? 5-Pin??? Huh?!?

If you use a controller with a 5 pin DMX output connector, you will need to use a 5 pin to 3 pin adapter. They are widely available over the internet and from specialty retailers. If you'd like to build your own, the chart below details a proper cable conversion:

Conductor	3-Pin Female (Output)	5-Pin Male (Input)
Ground/Shield	Pin 1	Pin 1
DMX Data (-)	Pin 2	Pin 2
DMX Data (+)	Pin 3	Pin 3
Not Used.	No Connection.	No Connection.
Not Used.	No Connection.	No Connection.

## Take It To The Next Level: Setting Up DMX Control

**Step 1:** Connect the male connector of the DMX cable to the female connector (output) on the controller.



**Step 2:** Connect the female connector of the DMX cable to the first fixture's male connector (input). *Note:* It doesn't matter which fixture address is the first one connected. We recommend connecting the fixtures in terms of their proximity to the controller, rather than connecting the lowest fixture number first, and so on.

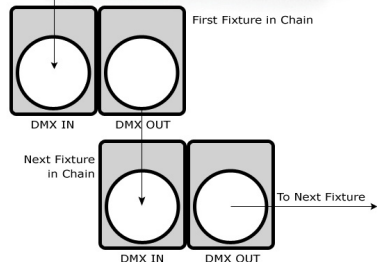

**Step 3:** Connect other fixtures in the chain from output to input as above. Place a DMX terminator on the output of the final fixture to ensure best communication.



## Fixture Linking (Master/Slave Mode)

1. Connect the (male) 3 pin connector side of the DMX cable to the output (female) 3 pin connector of the first fixture.
2. Connect the end of the cable coming from the first fixture which will have a (female) 3 pin connector to the input connector of the next fixture consisting of a (male) 3 pin connector. Then, proceed to connect from the output as stated above to the input of the following fixture and so on.

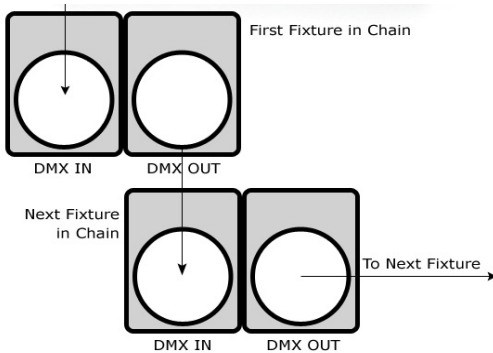

**A quick note:** Often, the setup for Master-Slave and Standalone operation requires that the first fixture in the chain be initialized for this purpose via either settings in the control panel or DIP-switches. Secondly, the fixtures that follow may also require a slave setting.

Check the **"Operating Adjustments"** section in this manual for complete instructions for this type of setup and configuration.

## Mounting & Rigging

This fixture may be mounted in any SAFE position provided there is enough room for ventilation.

It is important never to obstruct the fan or vents pathway. Mount the fixture using a suitable "C" or "O" type clamp. The clamp should be rated to hold at least 10x the fixture's weight to ensure structural stability. Do not mount to surfaces with unknown strength, and ensure properly "rated" rigging is used when mounting fixtures overhead.

Adjust the angle of the fixture by loosening both knobs and tilting the fixture. After finding the desired position, retighten both knobs.

- When selecting installation location, take into consideration lamp replacement access (if applicable) and routine maintenance.
- Safety cables **MUST ALWAYS** be used.
- Never mount in places where the fixture will be exposed to rain, high humidity, extreme temperature changes or restricted ventilation.

## 4. OPERATING ADJUSTMENTS

### The Control Panel

All the goodies and different modes possible with the ToughPar™ Satelight LED are accessed by using its control panel. There are 2 control buttons below the 3 character LED display which allow you to navigate through the various control panel menus.

#### <A>

Function Button: Used to scroll through main menu functions.

#### <B>

Setup Button: Used to scroll through & select submenu items.

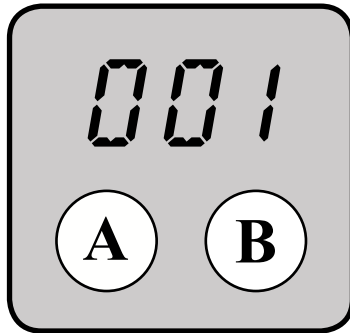

The control panel LED display shows the menu items you select from the menu map on page #11. Press the <A> button repeatedly until you reach the desired menu function. When a menu function is selected, the display will immediately show the first available option for this selected menu function.

Use the <B> button to navigate the options. Press <A> to either scroll to the next currently displayed option, or return to scrolling the main menu (depending if there is, or is not, more than 1 option per each of the 3 digits currently on the LED display). If you do not press any key for 30 seconds, the state will be automatically saved and will stop flashing.

## Control Panel Menu Structure

<i>001</i>	→	<i>001 - 512</i>	To choose the DMX address
<i>PSA</i>	→		Sets the fixture to run in slave mode
<i>PA -</i>	→	<i>PA5 - PA9</i>	To choose 5 or 9 channel DMX mode
<i>Pd -</i>	→	<i>Pd0 - Pd4</i>	To choose 32-bit dimming mode 0-4
<i>P0 -</i>	→	<i>P00 - P09</i>	Red intensity from 0-9 (0% <--> 100%)
<i>P1 -</i>	→	<i>P10 - P19</i>	Blue intensity from 0-9 (0% <--> 100%)
<i>P2 -</i>	→	<i>P20 - P29</i>	Green intensity from 0-9 (0% <--> 100%)
<i>P3 -</i>	→	<i>P30 - P39</i>	White intensity from 0-9 (0% <--> 100%)
<i>P4 -</i>	→	<i>P40 - P49</i>	Strobe intensity from 0-9 (slow <--> fast)
<i>P5 -</i>	→	<i>P50 - P59</i>	Color jump, speed 0-9 (slow <--> fast)
<i>P6 -</i>	→	<i>P60 - P69</i>	Color fade, speed 0-9 (slow <--> fast)

## Adjust the Starting DMX Address

- 1.) To adjust the starting DMX channel, first push the "A" button once so the 3rd (right) digit is flashing.
- 2.) Push the "B" button to adjust this digit to a value of 0-9.
- 3.) Repeating the same process, push the "A" button once so the 2nd (middle) digit is flashing.
- 4.) Push the "B" button to adjust this digit to a value of 0-9.
- 5.) Repeating the same process, push the "A" button once so the 1st (left) digit is flashing.
- 6.) Push the "B" button to adjust this digit to a value of 0-5.
- 7.) Pushing the "A" button once more will finalize your choice of the starting DMX address with the value being in the range of 001-512.

## Slave Mode

- 1.) To set the fixture in slave mode, press the "A" button until you reach "PSA" on the LED display. This fixture is now set to slave mode and will automatically follow the first unit in the DMX chain, aka the "Master".

## DMX Channel Mode

To set the fixture to run in either 5-channel or 9-channel DMX mode:

- 1.) Push the "A" button until the LED display reads "PA-".
- 2.) The right digit will be flashing. Use the "B" button to switch between the choices of "5" or "9".

## Dimming Mode

The ToughPar Satellight features ultra smooth flicker-free 32-bit dimming with 5 user-selectable dimming curves. To manually set the fixture to use one of these 5 dimming curve choices, simply do the following:

- 1.) Push the "A" button until the LED display reads "PD-"
- 2.) The right digit will be flashing. Use the "B" button to switch between the choices of dimming curve number 0-4.

## Built-in Programs

In built-in program mode, each of the 3 digits on the LED screen signify separate meanings.

**Left Digit:** Shows "P", for "Program Mode"

**Middle Digit:** Represents the built-in program 0-6.

**Right Digit:** Modifies the selected program.

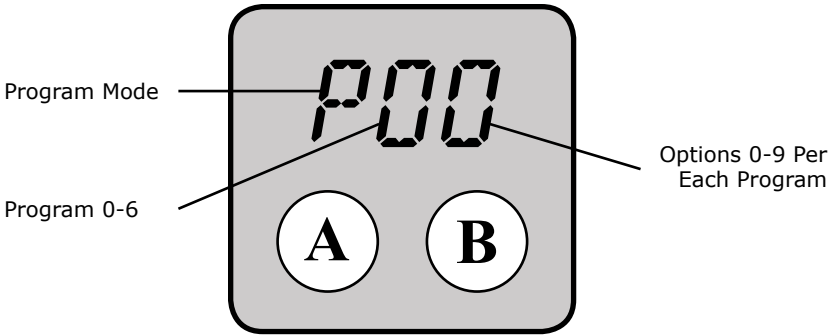

### **Red Intensity**

- 1.) Push the "A" button until the LED display reads "P0-".
- 2.) The right digit will be flashing. Use the "B" button to choose the intensity level from 0-9 (0% <--> 100%).

### **Green Intensity**

- 1.) Push the "A" button until the LED display reads "P1-".
- 2.) The right digit will be flashing. Use the "B" button to choose the intensity level from 0-9 (0% <--> 100%).

### **Blue Intensity**

- 1.) Push the "A" button until the LED display reads "P2-".
- 2.) The right digit will be flashing. Use the "B" button to choose the intensity level from 0-9 (0% <--> 100%).

### **White Intensity**

- 1.) Push the "A" button until the LED display reads "P3-".
- 2.) The right digit will be flashing. Use the "B" button to choose the intensity level from 0-9 (0% <--> 100%).

### **White Strobe Mode**

- 1.) Push the "A" button until the LED display reads "P4-".
- 2.) The right digit will be flashing. Use the "B" button to choose the rate from 0-9 (slow <--> fast).

### **Color Jump Mode**

- 1.) Push the "A" button until the LED display reads "P5-".
- 2.) The right digit will be flashing. Use the "B" button to choose the speed from 0-9 (slow <--> fast).

### **Color Fade Mode**

- 1.) Push the "A" button until the LED display reads "P6-".
- 2.) The right digit will be flashing. Use the "B" button to choose the speed from 0-9 (slow <--> fast).

## DMX Values In-Depth (5-Channel Mode)

Channel	Value	What It Does
1	000 <--> 255	<b>Red Intensity (0% &lt;--&gt; 100%)</b>
2	000 <--> 255	<b>Green Intensity (0% &lt;--&gt; 100%)</b>
3	000 <--> 255	<b>Blue Intensity (0% &lt;--&gt; 100%)</b>
4	000 <--> 255	<b>White Intensity (0% &lt;--&gt; 100%)</b>
5	000 <--> 005 006 <--> 055 056 <--> 105 106 <--> 155 156 <--> 205 206 <--> 255	<b>32-Bit Dimmer</b> As set in the control menu display Mode 0 = 8-bit, 256 dimming steps Mode 1 = 32-bit, 0-25% intensity range Mode 2 = 32-bit, 0-50% intensity range Mode 3 = 32-bit, 0-75% intensity range Mode 4 = 32-bit, full intensity dimming

## DMX Values In-Depth (9-Channel)

Channel	Value	What It Does
1	000 <--> 255	<b>Dimmer (0% &lt;--&gt; 100%)</b>
2	000 <--> 255	<b>Red Intensity (0% &lt;--&gt; 100%)</b>
3	000 <--> 255	<b>Green Intensity (0% &lt;--&gt; 100%)</b>
4	000 <--> 255	<b>Blue Intensity (0% &lt;--&gt; 100%)</b>
5	000 <--> 255	<b>White Intensity (0% &lt;--&gt; 100%)</b>
6	000 <--> 010 011 <--> 255	<b>Strobe</b> Strobe Off Strobe, 1-20 Hz (Slow <--> Fast)
7	000 <--> 014 015 <--> 024 025 <--> 034 035 <--> 044 045 <--> 054 055 <--> 064 065 <--> 074 075 <--> 084 085 <--> 094 095 <--> 104 105 <--> 114 115 <--> 124 125 <--> 134 135 <--> 144 145 <--> 154 155 <--> 164 165 <--> 255	<b>Static Colors + Auto</b> Dimming Red Green Blue White Red + Green Red + Blue Red + White Green + Blue Green + White Blue + White Red + Green + Blue Red + Green + White Red + Blue + White Green + Blue + White Red + Green + Blue + White Auto Run (slow <--> fast)
8	000 <--> 015 016 <--> 255	<b>Auto Mode</b> No Function Fade Speed (slow <--> fast)
9	000 <--> 005 006 <--> 055 056 <--> 105 106 <--> 155 156 <--> 205 206 <--> 255	<b>32-Bit Dimmer</b> As set in the control menu display Mode 0 = 8-bit, 256 dimming steps Mode 1 = 32-bit, 0-25% intensity range Mode 2 = 32-bit, 0-50% intensity range Mode 3 = 32-bit, 0-75% intensity range Mode 4 = 32-bit, full intensity dimming

## Troubleshooting

Symptom	Solution
Fixture Auto-Shut Off	Check the fan in the fixture. If it is stopped or moving slower than normal, the unit may have shut itself off due to high heat. This is to protect the fixture from overheating. Clear the fan of obstructions, or return the unit for service.
Beam is Dim	Check optical system and clean excess dust/grime. Also ensure that the 220V/110V switch is in the correct position, if applicable.
No Light Output	Check to ensure fixture is operating under correct mode, IE sound active/auto/DMX/Etc., if applicable. Contact service for more information.
Chase Speed Too Fast/Slow	Check to ensure proper setup of speed adjustment.
No Power	Check fuse, AC cord and circuit for malfunction.
Blown Fuse	Check AC cord and circuit for damage, verify that moving parts are not restricted and that unit's ventilation is not obstructed
Slow Movement	Verify that 220V/110V switch is in the correct position, if applicable. Also check that speed channels are set appropriately.
No Response to Audio	Verify that the fixture is in "Sound Active" mode. Adjust Audio Sensitivity, If Applicable.
Fixture Not Responding / Responding Erraticly	Make sure all connectors are seated properly and securely. Use Only DMX Cables. Install a Terminator. Check all cables for defects. Reset fixture(s).
Intermittant Lamp	Check lamp for properly installation. Relamp, lamp may have reached end of life.
Remote Doesn't Work	Verify remote control cable is installed properly and securely. Verify remote is correct type (CA-9 or other as applicable.)
Fixture Moving On Its Own	Verify proper mode of operation. Is the fixture in "Auto" mode?

**If your problem isn't listed, or if problems persist, please contact support: [support@blizzardlighting.com](mailto:support@blizzardlighting.com).**

# Dimensional Diagram

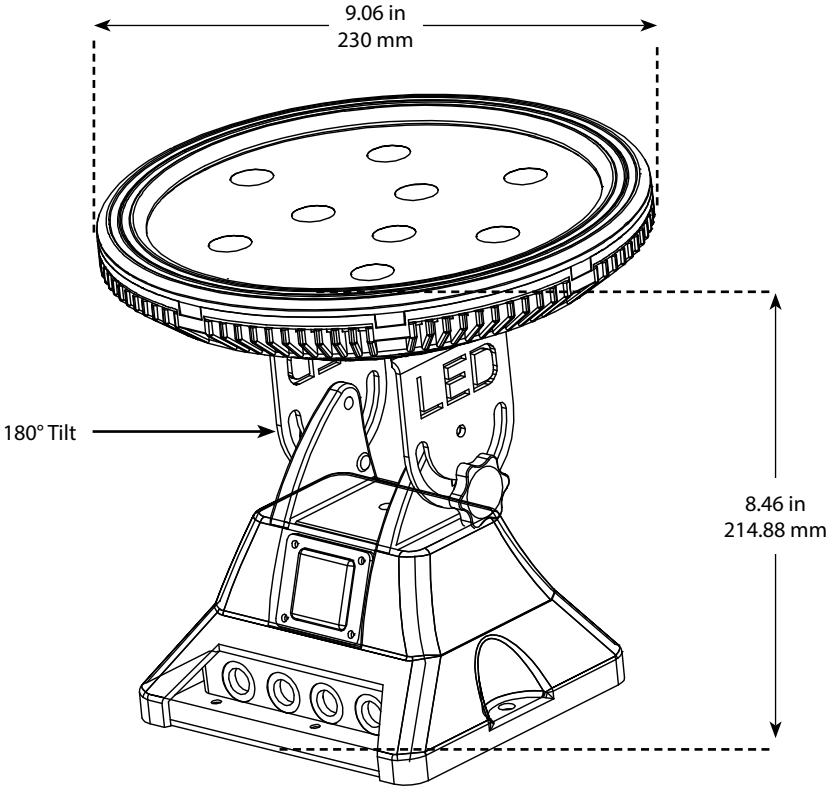



# 5. APPENDIX

## A Quick Lesson On DMX

DMX (aka DMX-512) was created in 1986 by the United States Institute for Theatre Technology (USITT) as a standardized method for connecting lighting consoles to lighting dimmer modules. It was revised in 1990 and again in 2000 to allow more flexibility. The Entertainment Services and Technology Association (ESTA) has since assumed control over the DMX512 standard. It has also been approved and recognized for ANSI standard classification.

DMX covers (and is an abbreviation for) Digital MultipleXed signals. It is the most common communications standard used by lighting and related stage equipment.

DMX provides up to 512 control "channels" per data link. Each of these channels was originally intended to control lamp dimmer levels. You can think of it as 512 faders on a lighting console, connected to 512 light bulbs. Each slider's position is sent over the data link as an 8-bit number having a value between 0 and 255. The value 0 corresponds to the light bulb being completely off while 255 corresponds to the light bulb being fully on.

DMX data is transmitted at 250,000 bits per second using the RS-485 transmission standard over two wires. As with microphone cables, a grounded cable shield is used to prevent interference with other signals.

There are five pins on a DMX connector: a wire for ground (cable shield), two wires for "Primary" communication which goes from a DMX source to a DMX receiver, and two wires for a "Secondary" communication which goes from a DMX receiver back to a DMX source. Generally, the "Secondary" channel is not used so data flows only from sources to receivers. Hence, most of us are most familiar with DMX-512 as being employer over typical 3-pin "mic cables," although this does not conform to the defined standard.

DMX is connected using a daisy-chain configuration where the source connects to the input of the first device, the output of the first device connects to the input of the next device, and so on. The standard allows for up to 32 devices on a single DMX link.

Each receiving device typically has a means for setting the "starting channel number" that it will respond to. For example, if two 6-channel fixtures are used, the first fixture might be set to start at channel 1 so it would respond to DMX channels 1 through 6, and the next fixture would be set to start at channel 7 so it would respond to channels 7 through 12.

The greatest strength of the DMX communications protocol is that it is very simple and robust. It involves transmitting a reset condition (indicating the start of a new "packet"), a start code, and up to 512 bytes of data. Data packets are transmitted continuously. As soon as one packet is finished, another can begin with no delay if desired (usually another follows within 1 ms). If nothing is changing (i.e. no lamp levels change) the same data will be sent out over and over again. This is a great feature of DMX -- if for some reason the data is not interpreted the first time around, it will be re-sent shortly.

Not all 512 channels need to be output per packet, and in fact, it is very uncommon to find all 512 used. The fewer channels are used, the higher the "refresh" rate. It is possible to get DMX refreshes at around 1000 times per second if only 24 channels are being transmitted. If all 512 channels are being transmitted, the refresh rate is around 44 times per second.

In summary, since its design and evolution in the 1980's DMX has become the standard for lighting control. It is flexible, robust, and scalable, and its ability to control everything from dimmer packs to moving lights to foggers to lasers makes it an indispensable tool for any lighting designer or lighting performer.

## Keeping Your ToughPar™ Satelight As Good As New

The fixture you've received is a rugged, tough piece of pro lighting equipment, and as long as you take care of it, it will take care of you. That said, like anything, you'll need to take care of it if you want it to operate as designed. You should absolutely keep the fixture clean, especially if you are using it in an environment with a lot of dust, fog, haze, wild animals, wild teenagers or spilled drinks.

Cleaning the optics routinely with a suitable glass cleaner will greatly improve the quality of light output. Keeping the fans free of dust and debris will keep the fixture running cool and prevent damage from overheating.

In transit, keep the fixtures in cases. You wouldn't throw a prized guitar, drumset, or other piece of expensive gear into a gear trailer without a case, and similarly, you shouldn't even think about doing it with your shiny new light fixtures.

Common sense and taking care of your fixtures will be the single biggest thing you can do to keep them running at peak performance and let you worry about designing a great light show, putting on a great concert, or maximizing your client's satisfaction and "wow factor." That's what it's all about, after all!

### Returns (Gasp!)

We've taken a lot of precautions to make sure you never even have to worry about sending a defective unit back, or sending a unit in for service. But, like any complex piece of equipment designed and built by humans, once in a while, something doesn't go as planned. If you find yourself with a fixture that isn't behaving like a good little fixture should, you'll need to obtain a Return Authorization (RA).

Don't worry, this is easy. Just send an email to [support@blizzardlighting.com](mailto:support@blizzardlighting.com), and we'll issue you an RA. Then, you'll need to send the unit to us using a trackable, pre-paid freight method. We suggest using USPS Priority or UPS. Make sure you carefully pack the fixture for transit, and whenever possible, use the original box & packing for shipping.

When returning your fixture for service, be sure to include the following:

- 1.) Your contact information (Name, Address, Phone Number, Email address).
- 2.) The RA# issued to you
- 3.) A brief description of the problem/symptoms.

We will, at our discretion, repair or replace the fixture. Please remember that any shipping damage which occurs in transit to us is the customer's responsibility, so pack it well!

### Shipping Issues

**Damage incurred in shipping is the responsibility of the shipper, and must be reported to the carrier immediately upon receipt of the items. Claims must be made within seven (7) days of receipt.**

## Tech Specs!

<b>Weight &amp; Dimensions</b>						
Length	9.06 inches (230mm)					
Width	9.06 inches (230 mm)					
Height	8.46 inches (214.88 mm)					
Weight	7.8 lbs (3.5kg)					
<b>Power</b>						
Operating Voltage	100-240VAC, 50/60 Hertz					
Fuse	250V, 3A					
Power Consumption	62W, .82A, pf: .61					
<b>Light Source</b>						
LED	9x 10W 4-in-1 LEDs 100,000 hours.					
<b>Optical</b>						
Beam Angle	25 degree optics					
Luminous Intensity	Lux/m	Red	Green	Blue	White	All
	1m	2,083	3,400	4,020	7,470	15,660
	2m	860	1,070	1,200	2,150	4,860
<b>Thermal</b>						
Max. Operating Temp.	104 degrees F (40 degrees C) ambient					
<b>Control</b>						
Protocol	USITT DMX-512					
DMX Channels	5 / 9 channel modes					
Input	3-pin XLR Male					
Output	3-pin XLR Female					
Other Operating Modes	Standalone, Master/Slave, Sound Active, Color Preset					
<b>Other Information</b>						
Rice is really great if you want to eat 2000 of something.						
<b>Warranty</b>	2-year limited warranty, does not cover mal-function caused by damage to LED's.					



**Enjoy your product!  
Our sincerest thanks for your purchase!  
--The team @ Blizzard Lighting**