

## LED Monitor

Efficient and Convenient  
Smart Energy Saving Monitor

### ▶ 20M37D-B

20" class (19.5" diagonal)

### ▶ 19M37D-B

19" class (18.5" diagonal)



## Features

### FLICKER-SAFE

- Eye fatigue is a major concern when working overtime on the computer. LG's Almost-Zero Flicker Free technology, allows the ability to work longer and more comfortably without straining the eyes..

### COLOR WIZARD

- Improves vision impaired viewers to adjust the RED and GREEN levels accordingly to easily distinguish colors.

### SMART ENERGY SAVING

- LG's Smart Energy Saving Mode conserves energy by using luminance compensation algorithm.

## Specifications

Native Display Resolution 1366 x 768 (19M37D-B)  
1600 x 900 (20M37D-B)

High Brightness 200 cd/m<sup>2</sup>

Viewing Angle (90/65)

Tilt and Base Detachable Stand

Vesa™ Compliant Wall Mountable

3-Year Limited Warranty Parts/Labor/Backlight

## Enhanced Usability for Convenience

### **DUAL** DUAL SMART SOLUTION Smart Solution

Dual Smart Solution is a function that allows the set-up of dual monitors, dual taskbars, and a split-screen function called dual web.



### **SUPER PLUS RESOLUTION**

Image distortion is unpleasant but it can also obscure important details in your work. Help solve this problem with Super Resolution, a revolutionary technology that decreases blur and picture degradation.



### **SMART ENERGY SAVING**

LG's Smart Energy Saving Mode reduces power consumption without lowering the brightness of the monitor.



### **COLOR WIZARD**

Improves the vision impaired viewing experience by adjusting the RED and GREEN levels accordingly to easily distinguish colors.

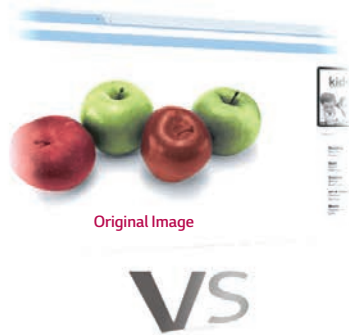

**VS**

# Eye-Comforting Display

**Flicker SAFE** FLICKER-SAFE

LG's Flicker-Safe technology protects users' eyes from fatigue by reducing flickering to almost zero

**Reader Mode**

With a touch of a button, Reader Mode allows the reduction of blue light emissions that can be harmful to the eyes.

**VS**

Conventional

Flicker

Conventional

Flicker Safe

Brightness / Frequency (Bright/High >)

Low

News Paper

Reader Mode

Novel

Textbook

Conventional

High

LG obtained TUV "flicker free" certification

## Dimensions

19M37D-B

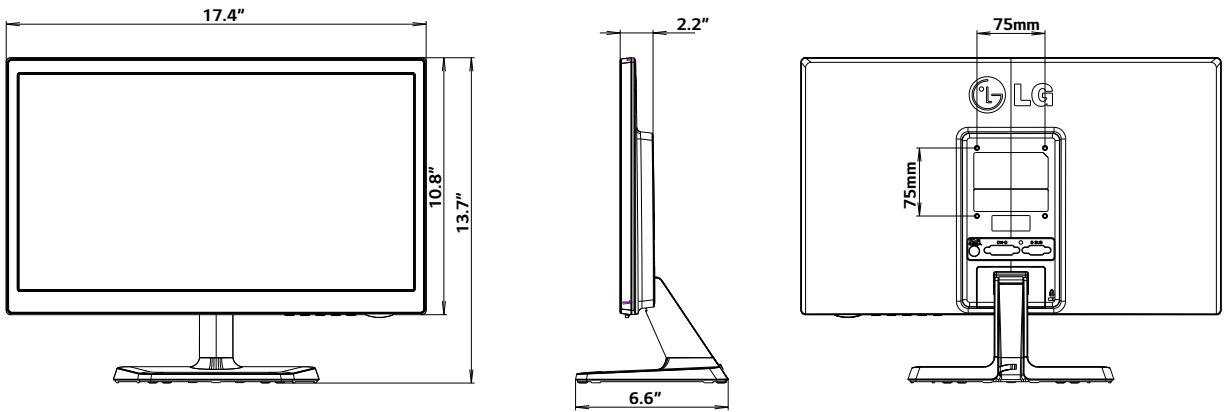

20M37D-B

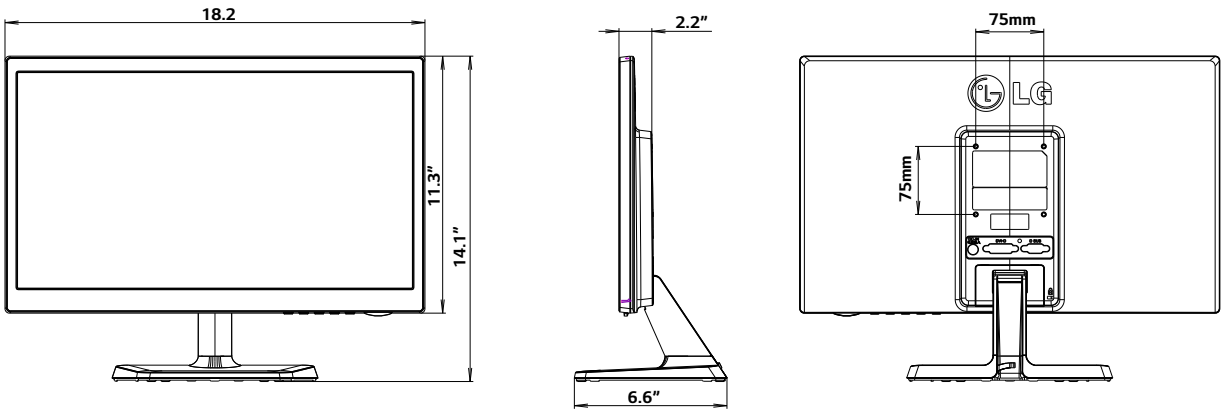

## Rear Jack Pack

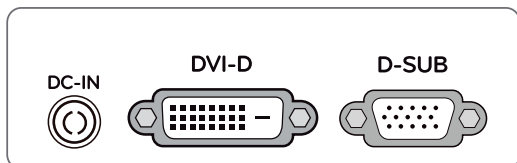

# LED Monitor

## Efficient and Convenient Smart Energy Saving Monitor

▶ 20M37D-B

20" class (19.5" diagonal)

▶ 19M37D-B

19" class (18.5" diagonal)

PANEL	Model	19M37D-B	20M37D-B
		Panel Size	19" class (18.5" diagonal)
	Panel Type	TN	
	Color Gamut (CIE1976)	72%	
	Color Depth (Number of Colors)	16.7M colors	
	Pixel Pitch (mm)	0.3 (H) x 0.3 (V)	0.271 (H) x 0.262 (V)
	Aspect Ratio	16:9	
	Native Resolution	1366 x 768	1600 x 900
	Brightness	200 cd/m <sup>2</sup>	
	Contrast Ratio (Typ.)	600:1	
	Dynamic CR (DFC)	5,000,000:1	
	Response Time (on/off)	5ms	
	Viewing Angle (CR 10)	90°/65°	
	Surface Treatment	Anti-glare, (3H)	
SIGNAL (INPUT)	D-Sub	Yes	
	DVI-D	Yes	
POWER	Power Type	Adapter	
	Power Supply	100 ~ 240 Vac, 50/60 Hz	
	Normal On (EPA)	13 W	16 W
	Normal On (typ.)	18 W	20 W
	Sleep Mode (Max)	0.3 W	
	DC Off (Max)	0.3W	
SPECIAL FEATURES	Picture Mode	Yes	
	Reader Mode	Yes	
	Original Ratio	Yes	
	DDC/CI	Yes	
	HDCP	Yes	
	Intelligent Auto (Auto Adjustment)	Yes	
	Key Lock	Yes	
	Plug & Play	Yes	
	Color Wizard	Yes	
	Dual Smart Solution (Dual web, Dual Display, Smart Resolution)	Yes	
	Flicker Safe	Yes	
	Smart Energy Saving	Yes	

CABINET	Model	19M37D-B	20M37D-B
		Color	Black Hairline
	Stand/Base Color	Black High Glossy	
	Monitor w/stand	17.4" x 6.6" x 13.7"	18.2" x 6.6" x 14.1"
	Monitor Weight	4.6 lbs	4.9 lbs
	Monitor w/o stand	17.4" x 2.2" x 10.8"	18.2" x 2.2" x 11.3"
	Monitor Weight	4.2 lbs	4.4 lbs
	Carton Dimensions	20.0" x 13.3" x 4.5"	21.2" x 14.0" x 4.5"
	Packed Weight	6.4 lbs	6.8 lbs
	Base Detachable	Yes	
	Tilt (Angle)	Yes, -5°~25°	
	Wall Mount	75mm x 75mm	
FREQUENCY	D-Sub (H-Frequency)	30 ~ 61 kHz	30 ~ 83 kHz
	D-Sub (V-Frequency)	56 ~ 75Hz	
	DVI-D (H-Frequency)	30 ~ 61kHz	30 ~ 83 kHz
	DVI-D (V-Frequency)	56 ~ 75Hz	
RESOLUTION	D-Sub (PC)	1366 x 768	1600 x 900
	Digital (DVI-D / HDMI)	1366 x 768	1600 x 900
STANDARD CERTIFICATIONS	UL(cUL)	Yes	
	FCC-B, CE	Yes	
	EPA 6.0	Yes	
	EPEAT	Yes (Gold)	
	Windows	Yes (Windows 8)	
WARRANTY	3-Year Limited Warranty (Parts/Labor/Backlight)		
UPC	7 19192 19629 2		7 19192 19559 2
ACCESSORIES	Power Cord	Yes	
	D-Sub	Yes	



LG Electronics U.S.A., Inc.  
HE B2B Division  
2000 Millbrook Drive  
Lincolnshire, IL 60069

Customer Service: 888.865.3026  
www.LGsolutions.com/support

Contact your LG Regional Sales Representative:  
Channel: 800.897.8871  
Hospitality: 800.228.1236  
E-mail: info@LGsolutions.com

SPEC\_19\_20M37D-B\_011502\_PR



All screen images are simulated. Dimensions and weights are approximate. Design, specifications, and features subject to change without notice.

© Copyright 2015 LG Electronics USA, Inc. All Rights Reserved. "LG Life's Good" is a registered trademark of LG Corp.

ENERGY STAR is a registered trademark of the U.S. Environmental Protection Agency. In Plane Switching is a trademark of LG Philips LCD Ltd. VESA is a trademark of Video Electronics Standards Association. HDMI, the HDMI logo and High-Definition Multimedia Interface are trademarks or registered trademarks of HDMI Licensing LLC.

All other product and brand names are trademarks or registered trademarks of their respective companies.

Printed in the USA. January 2015