

STILETTO™ 19



Blizzard Lighting, LLC
www.blizzardlighting.com
Waukesha, WI USA
Copyright (c) 2014

TABLE OF CONTENTS

Stiletto™ Z19 Zoom Moving Head	1
1. Getting Started	3
What's In The Box?	3
Getting It Out Of The Box	3
Powering Up!	3
Getting A Hold Of Us	3
Safety Instructions (Don't Stick Your Hand In The Toaster!)	4
2. Meet The Stiletto™ Z19 Zoom Moving Head	5
Features	5
DMX Quick Reference	5
The Stiletto™ Z19 Pin-up Picture	6
3. Setup	7
Fuse Replacement	7
Connecting A Bunch Of Stiletto's	7
Data/DMX Cables	7
Cable Connectors	8
3-Pin??? 5-Pin??? Huh?	8
Take It To The Next Level: Setting up DMX Control	8
Fixture Linking (Master/Slave Mode)	9
Mounting/Rigging	9
Mounting Points	10
Clamp Mounting	11
Securing the fixture	11
4. Operating Adjustments	12
The Control Panel	12
Control Panel Menu Structure	13
Advanced Settings	13
View Fixture Info (Hours, Version#)	13
Display On/Off	13
Manual Adjustments	13
DMX, Auto & Sound Active Modes	13
Invert the Pan and Tilt	13
Manual Settings	14
System Reset	14
Luminous Intensity Ratings	15
Photometric Chart	16
Troubleshooting	17
5. Appendix	18
A Quick DMX Lesson	18
Keeping Your Stiletto™ Z19 As Good As New	19
Returns (Gasp!)	19
Shipping Issues	19
Tech Specs	20

1. GETTING STARTED

What's In The Box?

- 1 x Stiletto™ Z19 Zoom Moving Head
- An Ever-So-Handy Power Cord
- A Sweet Safety Cable & set of Mounting Brackets
- This Lovely User Manual

Getting It Out Of The Box

Congratulations on your purchase of the amazing Stiletto™ Z19 Zoom LED moving head. With a name like Stiletto™ Z19 Zoom, its gotta razor cool! Now that you've got your Stiletto™ Z19 Zoom (or hopefully, Stiletto's!), you should carefully unpack the box and check the contents to ensure that all parts are present and in good condition. If anything looks as if it has been damaged in transit, notify the shipper immediately and keep the packing material for inspection. Again, please save the carton and all packing materials. If a fixture must be returned to the factory, it is important that the fixture be returned in the original factory box and packing.

Powering Up!

All fixtures must be powered directly off a switched circuit and **cannot be run off a rheostat (variable resistor) or dimmer circuit, even if the rheostat or dimmer channel is used solely for a 0% to 100% switch.**

AC Voltage Switch - Not all fixtures have a voltage select switch, so please verify that the fixture you receive is suitable for your local power supply. See the label on the fixture or refer to the fixture's specifications chart for more information. A fixture's listed current rating is its average current draw under normal conditions. Check the fixture or device carefully to make sure that if a voltage selection switch exists that it is set to the correct line voltage you will use.

Warning! Verify that the voltage select switch on your unit matches the line voltage applied. Damage to your fixture may result if the line voltage applied does not match the voltage indicated on the voltage selector switch. All fixtures must be connected to circuits with a suitable Ground (Earthing).

Getting A Hold Of Us

If something is wrong, please just visit our website at www.blizzardlighting.com and open a support ticket. We'll be happy to help, honest.

Blizzard Lighting
N16 W23390 Stoneridge Dr. Ste E
Waukesha, WI 53188 USA
www.blizzardlighting.com
414-395-8365

Disclaimer: The information and specifications contained in this document are subject to change without notice. Blizzard Lighting™ assumes no responsibility or liability for any errors or omissions that may appear in this user manual. Blizzard Lighting™ reserves the right to update the existing document or to create a new document to correct any errors or omissions at any time. You can download the latest version of this document from www.blizzardlighting.com.

Author:	Date:	Last Edited:	Date:
J. Henry	9/29/2014	J. Henry	10/08/2014

SAFETY INSTRUCTIONS



Please read these instructions carefully. They include important information about the installation, usage and maintenance of this product.

- Please keep this User Guide for future use. If you sell the unit to someone else, be sure that they also receive this User Guide.
- ALWAYS make sure that you are connecting to the proper voltage, and that the line voltage you are connecting to is not higher than that stated on the decal or rear panel of the fixture.
- This product is intended for indoor use only.
- To prevent risk of fire or shock, do not expose fixture to rain or moisture.
- Make sure there are no flammable materials close to the unit while operating.
- The unit must be installed in a location with adequate ventilation, at least 20in (50cm) from adjacent surfaces. Be sure that no ventilation slots are blocked.
- ALWAYS disconnect from the power source before servicing or replacing fuse and be sure to replace with same fuse size and type.
- ALWAYS secure fixture using a safety chain. NEVER carry the fixture by its head. Use its carrying handles.
- DO NOT operate at ambient temperatures higher than 104°F (40°C).
- In the event of a serious operating problem, stop using the unit immediately. NEVER try to repair the unit by yourself. Repairs carried out by unskilled people can lead to damage or malfunction. Please contact the nearest authorized technical assistance center. Always use the same type spare parts.
- NEVER connect the device to a dimmer pack.
- Make sure the power cord is never crimped or damaged.
- Never disconnect the power cord by pulling or tugging on the cord.
- Avoid direct eye exposure to the light source while it is on.

Caution! There are no user serviceable parts inside the unit. Do not open the housing or attempt any repairs yourself. In the unlikely event your unit may require service, please open a support ticket at www.blizzardlighting.com/tickets.

2. MEET THE STILETTO™ Z19 ZOOM MOVING HEAD

MAIN FEATURES

- 19 x 12.8w RGBW LED Zoom Moving Head
- Motorized linear zoom system, ratio 7:1 Beam aperture 7°-50°
- Pan: 540° / Tilt: 270°
- Extreme accurate motors with 16-bit resolution
- User selectable 12/21/27-channel DMX modes
- Pixel controllable sections with 4-in-1 LED coloring via 27ch DMX
- Flicker-free, source management, suitable for TV applications & video recording
- High-efficiency optical system
- Virtual color wheel
- White color temperature presets
- 3-pin / 5-pin male/female input and outputs
- PowerCon™ compatible AC power In/Out connectors

DMX Quick Reference (12/21/27-Channel Modes)

Channel	Short Mode	Standard	Extended Mode
1	Pan	Pan	Pan
2	Tilt	Tilt	Fine Pan
3	Zoom	Pan/Tilt Speed	Tilt
4	Dimmer	Zoom	Fine Tilt
5	Strobe	Dimmer	Pan/Tilt Speed
6	Red	Strobe	Zoom
7	Green	Pixel Section 1 Red	Dimmer
8	Blue	Pixel Section 1 Green	Strobe
9	White	Pixel Section 1 Blue	Red Global
10	Macros	Pixel Section 1 White	Green Global
11	Macro Speed	Pixel Section 2 Red	Blue Global
12	Reset	Pixel Section 2 Green	White Global
13	--	Pixel Section 2 Blue	Pixel Section 1 Red
14	--	Pixel Section 2 White	Pixel Section 1 Green
15	--	Pixel Section 3 Red	Pixel Section 1 Blue
16	--	Pixel Section 3 Green	Pixel Section 1 White
17	--	Pixel Section 3 Blue	Pixel Section 2 Red
18	--	Pixel Section 3 White	Pixel Section 2 Green
19	--	Macros	Pixel Section 2 Blue
20	--	Macro Speed	Pixel Section 2 White
21	--	Reset	Pixel Section 3 Red
22	--	--	Pixel Section 3 Green
23	--	--	Pixel Section 3 Blue
24	--	--	Pixel Section 3 White
25	--	--	Macros
26	--	--	Macro Speed
27	--	--	Reset

Figure 1: The Stiletto™ Z19 Zoom Pin-Up Picture



Figure 2: The Rear Connections

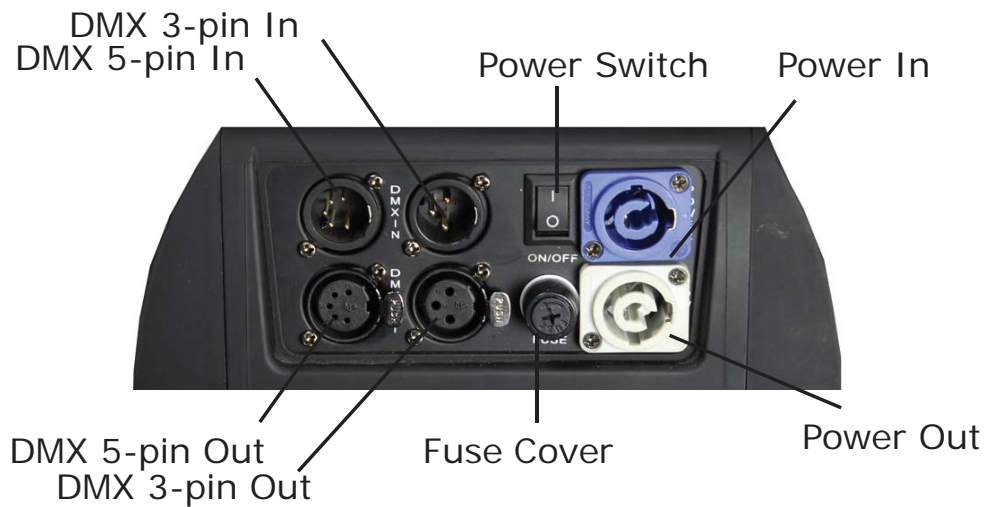

3. SETUP



Before replacing a fuse, disconnect power cord. ALWAYS replace with the same type and rating of fuse.

Fuse Replacement

With a flat head screwdriver, wedge the fuse holder out of its housing. Remove the damaged fuse from its holder and replace with exact same type fuse. Insert the fuse holder back in its place and reconnect power.

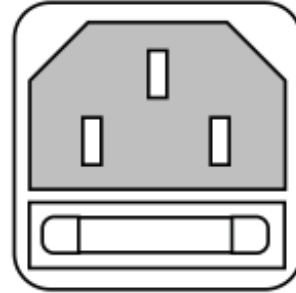

Connecting A Bunch of Stiletto Z19 Fixtures™

You will need a serial data link to run light shows using a DMX-512 controller or to run shows on two or more fixtures set to sync in master/slave operating mode. The combined number of channels required by all the fixtures on a serial data link determines the number of fixtures the data link can support.

Fixtures on a serial data link must be daisy chained in one single line. Also, connecting more than 32 fixtures on one serial data link without the use of a DMX optically-isolated splitter may result in deterioration of the digital DMX signal.

The maximum recommended cable-run distance is 500 meters (1640 ft). The maximum recommended number of fixtures on a serial data link is 32 fixtures.

Data/DMX Cabling

To link fixtures together you'll need data cables. You should use data-grade cables that can carry a high quality signal and are less prone to electromagnetic interference.

For instance, Belden© 9841 meets the specifications for EIA RS-485 applications. Standard microphone cables will "probably" be OK, but note that they cannot transmit DMX data as reliably over long distances. In any event, the cable should have the following characteristics:

2-conductor twisted pair plus a shield

Maximum capacitance between conductors – 30 pF/ft.

Maximum capacitance between conductor & shield – 55 pF/ft.

Maximum resistance of 20 ohms / 1000 ft.

Nominal impedance 100 – 140 ohms

Cable Connectors

Cables must have a male XLR connector on one end and a female XLR connector on the other end. (Duh!)

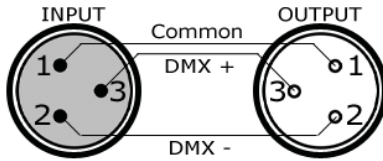

A Word on Termination: DMX is a resilient communication protocol, however errors still occasionally occur. Termination reduces signal errors, and therefore best practices include use of a terminator in all circumstances. If you are experiencing problems with erratic fixture behavior, especially over long signal cable runs, a terminator may help improve performance.

To build your own DMX Terminator:
Obtain a 120-ohm, 1/4-watt resistor, and wire it between pins 2 & 3 of the last fixture. They are also readily available from specialty retailers.

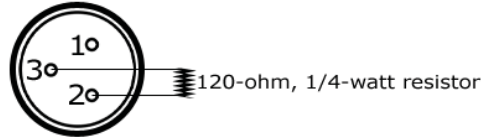

CAUTION: Do not allow contact between the common and the fixture's chassis ground. Grounding the common can cause a ground loop, and your fixture may perform erratically. Test cables with an ohm meter to verify correct polarity and to make sure the pins are not grounded or shorted to the shield or each other.

3-Pin??? 5-Pin??? Huh!??

If you use a controller with a 5 pin DMX output connector, you will need to use a 5 pin to 3 pin adapter. They are widely available over the internet and from specialty retailers. If you'd like to build your own, the chart below details a proper cable conversion:

Conductor	3-Pin Female (Output)	5-Pin Male (Input)
Ground/Shield	Pin 1	Pin 1
DMX Data (-)	Pin 2	Pin 2
DMX Data (+)	Pin 3	Pin 3
Not Used.	No Connection.	No Connection.
Not Used.	No Connection.	No Connection.

Take It To The Next Level: Setting Up DMX Control

Step 1: Connect the male connector of the DMX cable to the female connector (output) on the controller.

Step 2: Connect the female connector of the DMX cable to the first fixture's male connector (input). *Note:* It doesn't matter which fixture address is the first one connected. We recommend connecting the fixtures in terms of their proximity to the controller, rather than connecting the lowest fixture number first, and so on.

Step 3: Connect other fixtures in the chain from output to input as above. Place a DMX terminator on the output of the final fixture to ensure best communication.

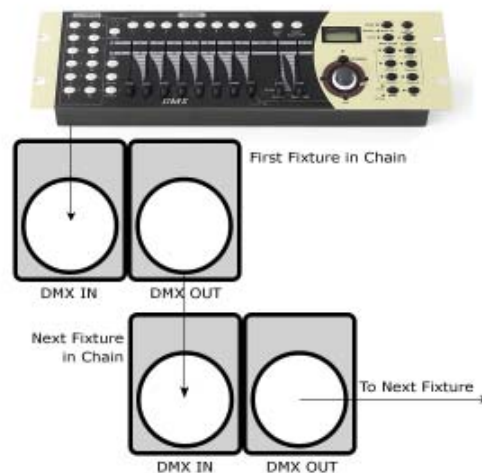

Fixture Linking (Master/Slave Mode)

1. Connect the (male) 3 pin connector side of the DMX cable to the output (female) 3 pin connector of the first fixture.
2. Connect the end of the cable coming from the first fixture which will have a (female) 3 pin connector to the input connector of the next fixture consisting of a (male) 3 pin connector. Then, proceed to connect from the output as stated above to the input of the following fixture and so on.

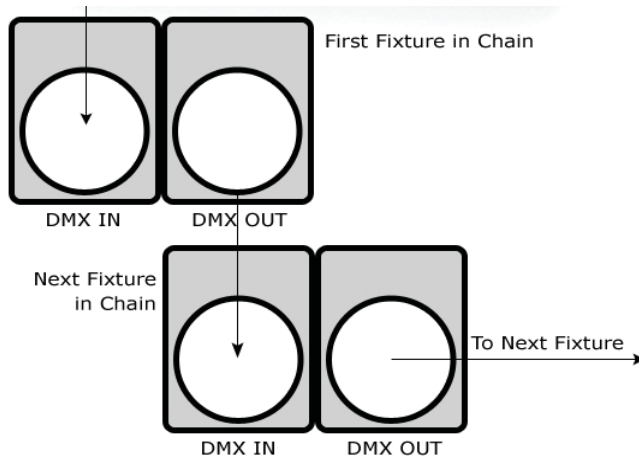

A quick note: Often, the setup for Master-Slave and Standalone operation requires that the first fixture in the chain be initialized for this purpose via either settings in the control panel or DIP-switches. Secondly, the fixtures that follow may also require a slave setting.

Check the “**Operating Adjustments**” section in this manual for complete instructions for this type of setup and configuration.

Mounting & Rigging

This fixture may be mounted in any SAFE position provided there is enough room for ventilation.

It is important never to obstruct the fan or vents pathway. Mount the fixture using a suitable “C” or “O” type clamp. The clamp should be rated to hold at least 10x the fixture’s weight to ensure structural stability. Do not mount to surfaces with unknown strength, and ensure properly “rated” rigging is used when mounting fixtures overhead.

Adjust the angle of the fixture by loosening both knobs and tilting the fixture. After finding the desired position, retighten both knobs.

- When selecting installation location, take into consideration lamp replacement access (if applicable) and routine maintenance.
- Safety cables **MUST ALWAYS** be used.
- Never mount in places where the fixture will be exposed to rain, high humidity, extreme temperature changes or restricted ventilation.

Mounting Points

Overhead mounting requires extensive experience, which includes calculating working load limits, knowledge of the installation material being used, and periodic safety inspection of all installation material and the fixture. If you lack these qualifications, do not attempt the installation yourself. Improper installation can result in bodily injury.

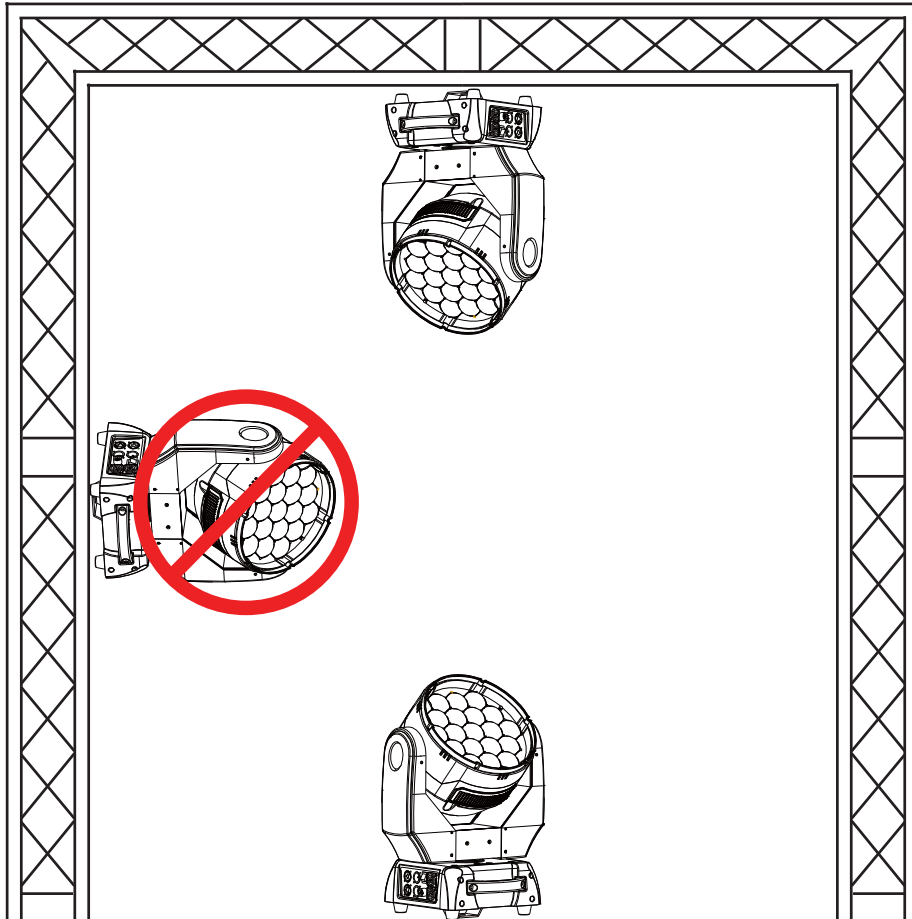

Caution!

Please be aware, you should have a qualified electrician performing all of your electrical connection needs. Better safe than sorry!

Be sure to complete all rigging and installation procedures before connecting the main power cord to the appropriate wall outlet.

Clamp Mounting

This fixture provides a mounting bracket assembly that secures the bottom of the base, the "Omega Brackets," and the safety cable rigging point together. When mounting this fixture to truss, be sure to secure an appropriately rated clamp to the omega bracket using an M10 screw fitted through the center hole of the "omega bracket".

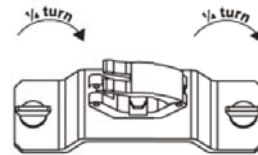
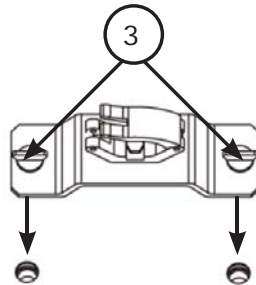
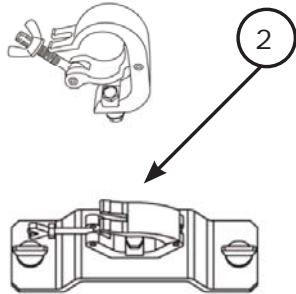
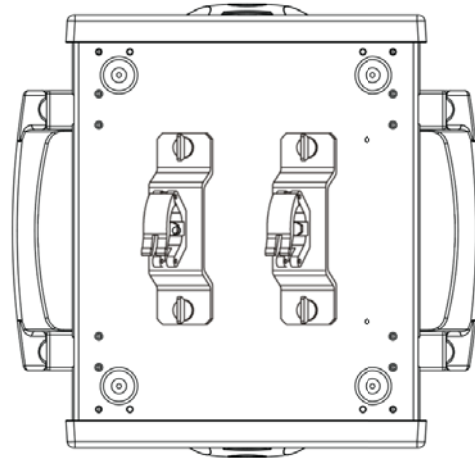
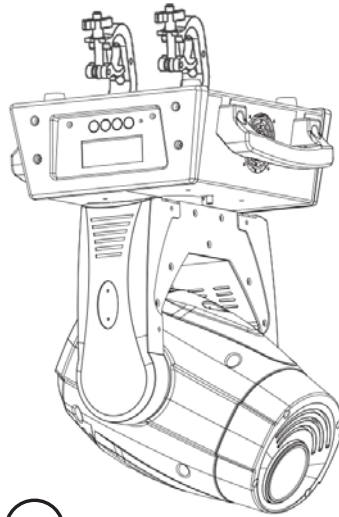

- 1.) Clamp
- 2.) Omega Bracket
- 3.) ¼ Turn Quick Lock Fasteners

Securing the Fixture

Regardless of the rigging option you choose for your fixtures always be sure to secure your fixture with a safety cable. Be sure to only use the designated rigging point found on the underside of the base assembly for the safety cable. Never secure a safety cable to a carrying handle.

4. OPERATING ADJUSTMENTS

The Control Panel

All the goodies and different modes possible with the Stiletto™ Z19 Zoom are accessed by using the control panel on the front of the fixture. There are 4 control buttons below the LCD display which allow you to navigate through the various control panel menus.



Button	Function
<MENU>	Used to access the menu or to return to a previous menu option.
<UP>	Scrolls through menu options in ascending order.
<DOWN>	Scrolls through menu options in descending order.
<ENTER>	Used to select and store the current menu or option within a menu.

Access control panel functions using the four panel buttons located directly underneath the LCD Display.

The Control Panel LCD Display shows the menu items you select from the menu map on page #11. When a menu function is selected, the display will show immediately the first available option for the selected menu function. To select a menu item, press **<ENTER>**.

Use the **<UP>** and **<DOWN>** buttons to navigate the menu map and menu options. Press the **<ENTER>** button to access the menu function currently displayed or to enable a menu option. To return to the previous option or menu without changing the value, press the **<MENU>** button.

Control Panel Menu Structure

Main Function	Sub Function	Selection	What It Does...	
Address	N/A	001 <-> 512	Sets the DMX address	
Default	Load Def?	No	Does not load Default system settings	
		Yes	Loads Default system settings	
View	Hours	Hours =	Displays hours used on fixture	
	Version	Version #	Displays current version of software	
	DMXValue	CH = 001 - 512 DMX = 000 - 255	Displays Channel and DMX settings established	
Advanced	Code	Code = 000	Use 008 to access adjustment settings	
	Mic Sens	Mic Sens = 075%	Set sound sensitivity from 0%-100%	
	Adjust	Pan		Corrective manual adjustment for +/- 000-255
		Tilt		Corrective manual adjustment for +/- 000-255
		Zoom		Corrective manual adjustment for +/- 000-255
		Red		Corrective manual adjustment for +/- 000-255
		Green		Corrective manual adjustment for +/- 000-255
		Blue		Corrective manual adjustment for +/- 000-255
		White		Corrective manual adjustment for +/- 000-255
Option	P&T Swap	P&T Swap = OFF	Swaps Pan & Tilt for programming purposes	
		P&T Swap = ON	Swaps Pan & Tilt for programming purposes	
	Lost DMX	Lost DMX = Clear	Sets fixture to clear last DMX program if DMX connection is lost	
		Lost DMX = Hold	Sets fixture to hold last DMX program if DMX connection is lost	
	Display	DelayOff	LCD display will turn off after 10 seconds	
		Always	LCD display will stay on indefinitely	
	Tilt Inv	Tilt Inv = OFF	Tilt will not be swapped	
		Tilt Inv = On	Tilt will be swapped	
	Pan Inv	Pan Inv = On	Pan will not be swapped	
		Pan Inv = Off	Pan will be swapped	
	Mode	Mode = DMX	Extended	27 Channel Mode
			Standard	21 Channel Mode
Short			12 Channel Mode	
Mode = Slave		<ENTER>	Puts fixture into Slave Mode	
Mode = Music		Music Alone	Sets fixture in single music operation mode	
		Music Master	Sets fixture as master music operation to be used with slave units	
Mode = Auto		Auto Alone	Sets fixture in single auto operation mode	
		Auto Master	Sets fixture as master auto operation to be used with slave units	

Control Panel Menu Structure (Continued)

Main Function	Sub Function	Selection	What It Does...
Manual	Pan	Pan =000-255	Manual setting for Pan
	Tilt	Tilt =000-255	Manual setting for Tilt
	Zoom	Zoom =000-255	Manual setting for Zoom
	Red	Red =000-255	Manual setting for Global Red LEDs
	Green	Green =000-255	Manual setting for Global Green LEDs
	Blue	Blue =000-255	Manual setting for Global Blue LEDs
	White	White =000-255	Manual setting for Global White LEDs
Reset	Reset =No	<Enter>	Select to not Reset fixture settings
	Reset =Yes	<Enter>	Select to Reset fixture settings

DMX Channel Values In-Depth

Short Mode	Standard Mode	Extended Mode	Channel Value	What it does
1	1	1	000 <-> 255	Pan (0° <-> 540°)
		2	000 <-> 255	Pan Fine
2	2	3	000 <-> 255	Tilt (0° <-> 270°)
		4	000 <-> 255	Tilt Fine
		5	000 <-> 255	Pan/Tilt Speed
3	4	6	000 <-> 255	Zoom
4	5	7	000 <-> 255	Dimmer
5	6	8	000 <-> 004	Strobe
			005 <-> 009	No Strobe
			010 <-> 229	Open
			230 <-> 249	Slow <-> Fast
			250 <-> 255	Random Color Strobe
6		9	000 <-> 255	Red Global
7		10	000 <-> 255	Green Global
8		11	000 <-> 255	Blue Global
9		12	000 <-> 255	White Global
	7	13	000 <-> 255	Pixel Section 1 Red
	8	14	000 <-> 255	Pixel Section 1 Green
	9	15	000 <-> 255	Pixel Section 1 Blue
	10	16	000 <-> 255	Pixel Section 1 White
	11	17	000 <-> 255	Pixel Section 2 Red
	12	18	000 <-> 255	Pixel Section 2 Green
	13	19	000 <-> 255	Pixel Section 2 Blue
	14	20	000 <-> 255	Pixel Section 2 White
	15	21	000 <-> 255	Pixel Section 3 Red
	16	22	000 <-> 255	Pixel Section 3 Green
	17	23	000 <-> 255	Pixel Section 3 Blue
	18	24	000 <-> 255	Pixel Section 3 White

DMX Channel Values In-Depth (Continued)

Short Mode	Standard Mode	Extended Mode	Channel Value	What it does
10	19	25	000 <-> 003	Macros No Function
			004 <-> 012	Macro 1
			013 <-> 021	Macro 2
			022 <-> 030	Macro 3
			031 <-> 039	Macro 4
			040 <-> 048	Macro 5
			049 <-> 057	Macro 6
			058 <-> 066	Macro 7
			067 <-> 075	Macro 8
			076 <-> 084	Macro 9
			085 <-> 093	Macro 10
			094 <-> 102	Macro 11
			103 <-> 111	Macro 12
			112 <-> 120	Macro 13
			121 <-> 129	Macro 14
			130 <-> 138	Macro 15
			139 <-> 147	Macro 16
			148 <-> 156	Macro 17
			157 <-> 165	Macro 18
			166 <-> 174	Macro 19
			175 <-> 183	Macro 20
			184 <-> 192	Macro 21
			193 <-> 201	Macro 22
			202 <-> 210	Macro 23
211 <-> 219	Macro 24			
220 <-> 228	Macro 25			
229 <-> 237	Macro 26			
238 <-> 246	Macro 27			
247 <-> 255	Mixing Macro			
11	20	26	000 <-> 255	Macro Speed
12	21	27	000 <-> 124	Reset No Function
			125 <-> 149	Reset
			150 <-> 255	No Function

Luminous Intensity						
	LUX/m	Red	Green	Blue	White	All
Zoomed Wide	1m	1,740	1,820	2,970	4,700	7,500
	2m	370	430	610	720	1,700
Zoomed Narrow	1m	10,710	12,100	17,190	20,060	51,300
	2m	5,220	5,640	8,440	9,540	23,500

****PLEASE SEE PAGE 16 FOR FULL 1M - 5M PHOTOMETRIC DISPLAY****

Photometric Data

7° Beam Angle LUX (White)

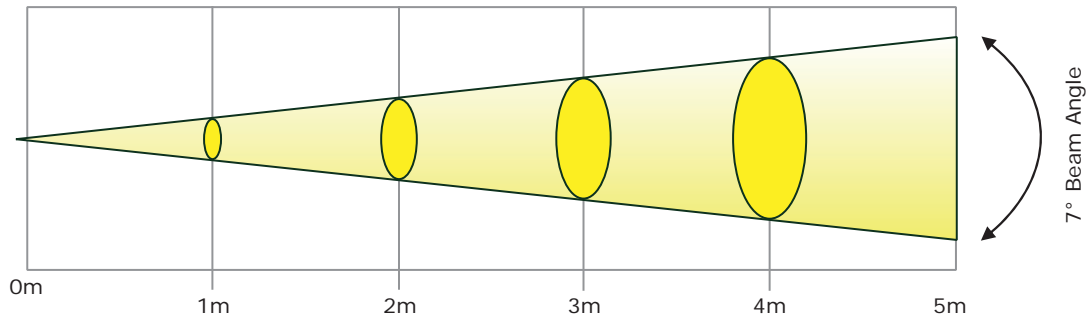

51,300 @ 1m	23,500 @ 2m	11,000 @ 3m	6,600 @ 4m	4,600 @ 5m
-------------	-------------	-------------	------------	------------

Photometric Data

50° Beam Angle LUX (White)

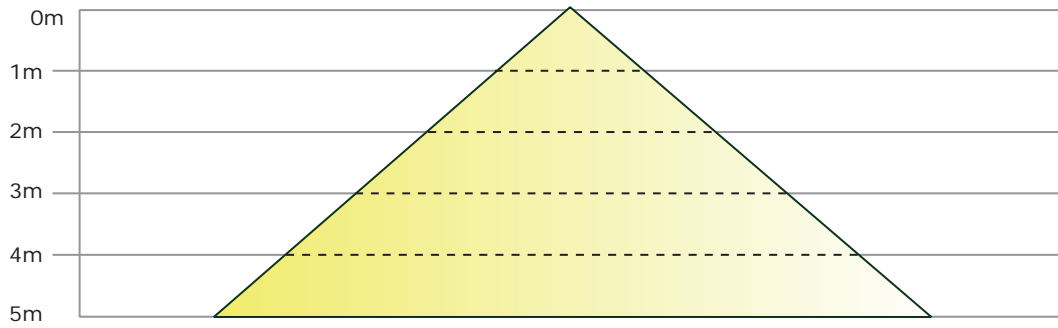

7,500 @ 1m	1,700 @ 2m	900 @ 3m	500 @ 4m	400 @ 5m
------------	------------	----------	----------	----------

Troubleshooting

Symptom	Solution
Fixture Auto-Shut Off	Check the fan in the fixture. If it is stopped or moving slower than normal, the unit may have shut itself off due to high heat. This is to protect the fixture from overheating. Clear the fan of obstructions, or return the unit for service.
Zoom is Dim	Check optical system and clean excess dust/grime. Also ensure that the 220V/110V switch is in the correct position, if applicable.
No Light Output	Check to ensure fixture is operating under correct mode, IE sound active/auto/DMX/Etc., if applicable. Contact service for more information.
Chase Speed Too Fast/Slow	Check to ensure proper setup of speed adjustment.
No Power	Check fuse, AC cord and circuit for malfunction.
Blown Fuse	Check AC cord and circuit for damage, verify that moving parts are not restricted and that unit's ventilation is not obstructed
Slow Movement	Verify that 220V/110V switch is in the correct position, if applicable. Also check that speed channels are set appropriately.
No Response to Audio	Verify that the fixture is in "Sound Active" mode. Adjust Audio Sensitivity, If Applicable.
Fixture Not Responding / Responding Erratically	Make sure all connectors are seated properly and securely. Use Only DMX Cables. Install a Terminator. Check all cables for defects. Reset fixture(s).
Intermittent Lamp	Check lamp for properly installation. Relamp, lamp may have reached end of life.
Fixture Moving On Its Own	Verify proper mode of operation. Is the fixture in "Auto" mode?

If your problem isn't listed, or if problems persist, please open a support ticket at www.blizzardlighting.com/tickets.

5. APPENDIX

A Quick Lesson On DMX

DMX (aka DMX-512) was created in 1986 by the United States Institute for Theatre Technology (USITT) as a standardized method for connecting lighting consoles to lighting dimmer modules. It was revised in 1990 and again in 2000 to allow more flexibility. The Entertainment Services and Technology Association (ESTA) has since assumed control over the DMX512 standard. It has also been approved and recognized for ANSI standard classification.

DMX covers (and is an abbreviation for) Digital MultipleXed signals. It is the most common communications standard used by lighting and related stage equipment.

DMX provides up to 512 control "channels" per data link. Each of these channels was originally intended to control lamp dimmer levels. You can think of it as 512 faders on a lighting console, connected to 512 light bulbs. Each slider's position is sent over the data link as an 8-bit number having a value between 0 and 255. The value 0 corresponds to the light bulb being completely off while 255 corresponds to the light bulb being fully on.

DMX data is transmitted at 250,000 bits per second using the RS-485 transmission standard over two wires. As with microphone cables, a grounded cable shield is used to prevent interference with other signals.

There are five pins on a DMX connector: a wire for ground (cable shield), two wires for "Primary" communication which goes from a DMX source to a DMX receiver, and two wires for a "Secondary" communication which goes from a DMX receiver back to a DMX source. Generally, the "Secondary" channel is not used so data flows only from sources to receivers. Hence, most of us are most familiar with DMX-512 as being employer over typical 3-pin "mic cables," although this does not conform to the defined standard.

DMX is connected using a daisy-chain configuration where the source connects to the input of the first device, the output of the first device connects to the input of the next device, and so on. The standard allows for up to 32 devices on a single DMX link.

Each receiving device typically has a means for setting the "starting channel number" that it will respond to. For example, if two 6-channel fixtures are used, the first fixture might be set to start at channel 1 so it would respond to DMX channels 1 through 6, and the next fixture would be set to start at channel 7 so it would respond to channels 7 through 12.

The greatest strength of the DMX communications protocol is that it is very simple and robust. It involves transmitting a reset condition (indicating the start of a new "packet"), a start code, and up to 512 bytes of data. Data packets are transmitted continuously. As soon as one packet is finished, another can begin with no delay if desired (usually another follows within 1 ms). If nothing is changing (i.e. no lamp levels change) the same data will be sent out over and over again. This is a great feature of DMX -- if for some reason the data is not interpreted the first time around, it will be re-sent shortly.

Not all 512 channels need to be output per packet, and in fact, it is very uncommon to find all 512 used. The fewer channels are used, the higher the "refresh" rate. It is possible to get DMX refreshes at around 1000 times per second if only 24 channels are being transmitted. If all 512 channels are being transmitted, the refresh rate is around 44 times per second.

In summary, since its design and evolution in the 1980's DMX has become the standard for lighting control. It is flexible, robust, and scalable, and its ability to control everything from dimmer packs to moving lights to foggers to lasers makes it an indispensable tool for any lighting designer or lighting performer.

Keeping Your Stiletto Z19 As Good As New

The fixture you've received is a rugged, tough piece of pro lighting equipment, and as long as you take care of it, it will take care of you. That said, like anything, you'll need to take care of it if you want it to operate as designed. You should absolutely keep the fixture clean, especially if you are using it in an environment with a lot of dust, fog, haze, wild animals, wild teenagers or spilled drinks.

Cleaning the optics routinely with a suitable glass cleaner will greatly improve the quality of light output. Keeping the fans free of dust and debris will keep the fixture running cool and prevent damage from overheating.

In transit, keep the fixtures in cases. You wouldn't throw a prized guitar, drumset, or other piece of expensive gear into a gear trailer without a case, and similarly, you shouldn't even think about doing it with your shiny new light fixtures.

Common sense and taking care of your fixtures will be the single biggest thing you can do to keep them running at peak performance and let you worry about designing a great light show, putting on a great concert, or maximizing your client's satisfaction and "wow factor." That's what it's all about, after all!

Returns (Gasp!)

We've taken a lot of precautions to make sure you never even have to worry about sending a defective unit back, or sending a unit in for service. But, like any complex piece of equipment designed and built by humans, once in a while, something doesn't go as planned. If you find yourself with a fixture that isn't behaving like a good little fixture should, you'll need to obtain a Return Authorization (RA).

Don't worry, this is easy. Just go to our website and open a support ticket at www.blizzardlighting.com/tickets, and we'll issue you an RA. Then, you'll need to send the unit to us using a trackable, pre-paid freight method. We suggest using USPS Priority or UPS. Make sure you carefully pack the fixture for transit, and whenever possible, use the original box & packing for shipping.

When returning your fixture for service, be sure to include the following:

- 1.) Your contact information (Name, Address, Phone Number, Email address).
- 2.) The RA# issued to you
- 3.) A brief description of the problem/symptoms.

We will, at our discretion, repair or replace the fixture. Please remember that any shipping damage which occurs in transit to us is the customer's responsibility, so pack it well!

Shipping Issues

Damage incurred in shipping is the responsibility of the shipper, and must be reported to the carrier immediately upon receipt of the items. Claims must be made within seven (7) days of receipt.

Tech Specs!

Weight & Dimensions	
Width	12.75 inches (325 mm)
Depth	9.5 inches (240 mm)
Height	16 inches (405 mm)
Weight	22.04lbs (10 kg)
Power	
Operating Voltage	110-240VAC 50/60Hz (autoranging)
Power Consumption	300w, 1.05a, pf: .97
Light Source	
LED	19 x 12.8w 4-in-1 RGBW LEDs
Optical	
Motorized Zoom	7° - 50°
Movement Range	
Pan	540 degrees
Tilt	270 degrees
Thermal	
Max. Operating Temp.	104 degrees F (40 degrees C) ambient
Control	
Protocol	USITT DMX-512
DMX Channels	12/21/27 channels
Input	3-pin/5-pin XLR Male
Output	3-pin/5-pin XLR Female
Other Information	
All barcode tattoos ring up as ranch dressing. Every single one of them.	
Warranty	2-year limited warranty, does not cover malfunction caused by damage to LED's.

DISCLAIMER:

The power connector fitted to the fixture and fixture cord are designed for compatibility with products manufactured by Neutrik AG, Neutrik USA and their related entities, however they are not manufactured by, affiliated with or endorsed by Neutrik AG, Neutrik USA, or any related entity. Neutrik® and powerCON® are registered trademarks of Neutrik AG.

This page left intentionally blank

This page left intentionally blank

This page left intentionally blank



**Enjoy your product!
Our sincerest thanks for your purchase!
--The team @ Blizzard Lighting**