

GRACE DESIGN



Spacebar

Stereo Microphone Positioning System

User Manual, Revision C, October 7, 2010

Table of Contents

Spacebar Components.....	3
Setup Procedure.....	5
Changing the mic holder height.....	6
Changing the horizontal bar length.....	6
Exploded parts diagram: Spacebar SB-30.....	7
Optional Center mount bridge SB-CMB.....	8
Exploded parts diagram: SB-CMB.....	9
Optional Spacebar Hanging Adapter SB-HB-30/66.....	10
Spacebar Hanging Adapter Setup Procedure.....	12
Revision History.....	13

Welcome and thanks for purchasing the Spacebar microphone positioner. We build all of our products to be completely reliable and easy to use, so you can concentrate on making great recordings. While the Spacebar setup and use is straightforward, please do familiarize yourself with this manual to help avoid any common user difficulties.

The Spacebar allows for precise and repeatable setting of microphone capsule spacing, angle of incidence, and rotation around the x axis. With precision scales for angle and distance engraved on the Spacebar components, it is easy to make perfectly repeatable stereo microphone setups.

As well as being able to precisely set microphones in standard stereo configurations (i.e. XY, ORTF, NOS, and AB 50cm), the Spacebar allows for exact settings through the entire continuum of angle and spacing. This allows the user to adjust the stereo microphone array and tailor the pickup field to suit virtually any recording environment.

We highly recommend *The Stereophonic Zoom* by Michael Williams, a technical paper that provides detailed information on the relationship between angle of incidence, capsule spacing, and the effective angle of the recorded sound field. It is a very useful reference that can greatly increase the flexibility of your stereo microphone techniques. *The Stereophonic Zoom* can be downloaded from:

<http://www.microphone-data.com/pdfs/Stereo%20zoom.pdf>

Spacebar systems are precision fabricated from machined aircraft aluminum, brass, and stainless steel. If properly cared for it should last a lifetime. In the event that you encounter any technical or operational difficulties with this or any Grace Design products, please feel free to contact us at 303-443-7454, 9 to 5, Monday through Friday, MST. Or you can email questions to: info@gracedesign.com



Spacebar Components

The standard Spacebar system consists of a center stand clamp, horizontal bar, and microphone holders.

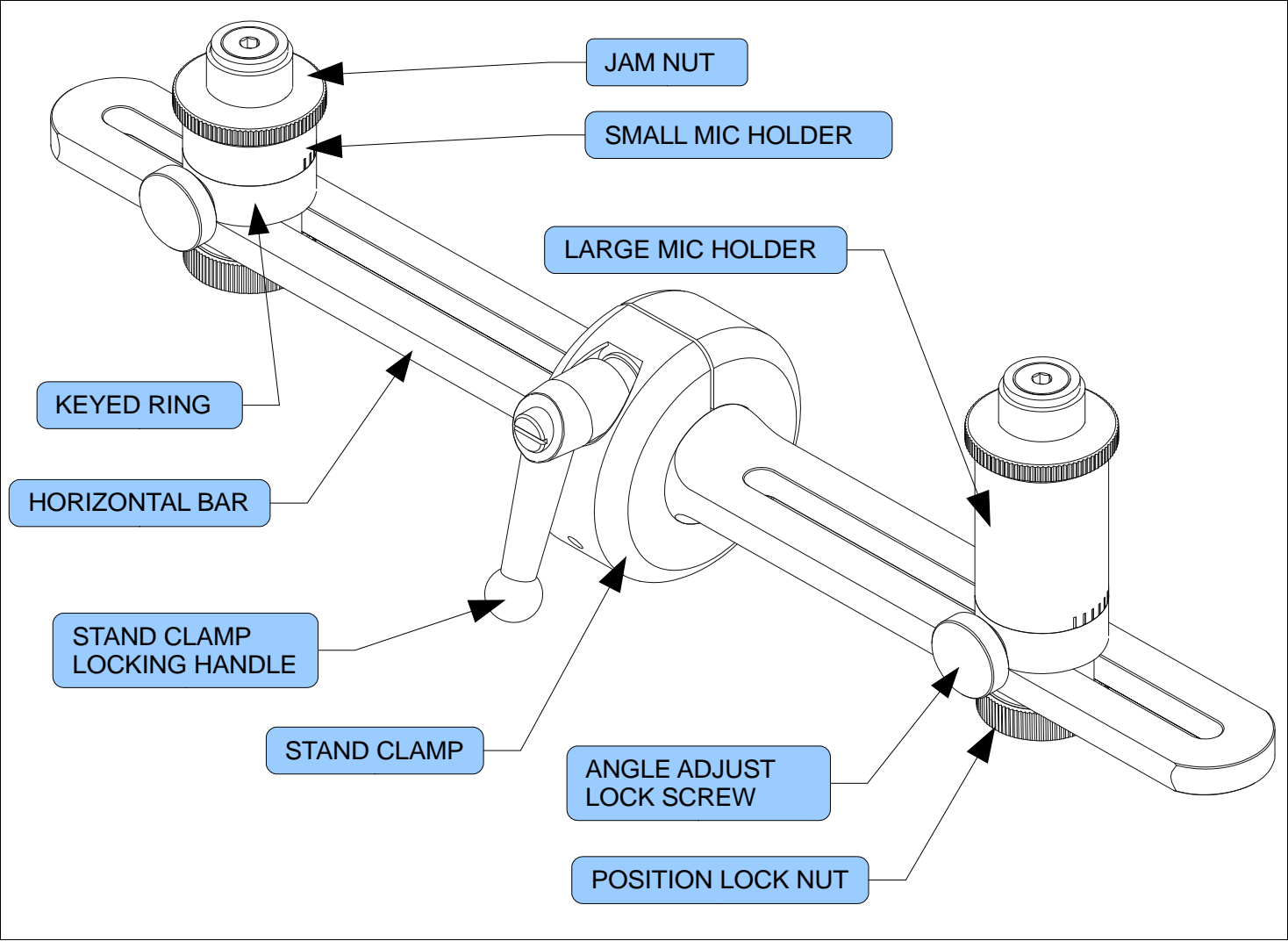

fig.1 Spacebar component diagram

The horizontal bar comes in two sizes: 30cm for the SB-30 and 66cm for the SB-66. The 30cm and 66cm horizontal bars are interchangeable in the field. The maximum microphone holder spacing is as follows:

Model	Minimum spacing	Maximum spacing
SB-30	7cm (2.75")	26cm (10.2")
SB-66	7cm (2.75")	61cm (24")

The stand clamp mounts on a standard 5/8"-27 microphone stand thread. *Note: the threaded section of the microphone stand should not be longer than 7/16". Threading the stand further than 7/16" into the stand clamp can cause the horizontal bar to bind and not rotate freely.*

The microphone holders are secured to the horizontal bar by the position lock nuts. Loosening these nuts will allow the microphone holders to slide side to side for adjusting the microphone spacing. The horizontal position can be adjusted with 5mm precision by using the ruler on the front of the horizontal bar. Note that these rulers are for reference as the actual capsule spacing will need to be determined with a measuring tape or ruler. The SB-30 and SB-66 are both supplied with two microphone holder assemblies and an additional tall microphone holder. The taller microphone holder body can be used to raise one microphone to avoid interference if the mic spacing requires that the microphone bodies overlap (see [Changing the mic holder height](#) later in this manual). Additional microphone holders can be purchased if more than two microphones are to be mounted to the Spacebar.

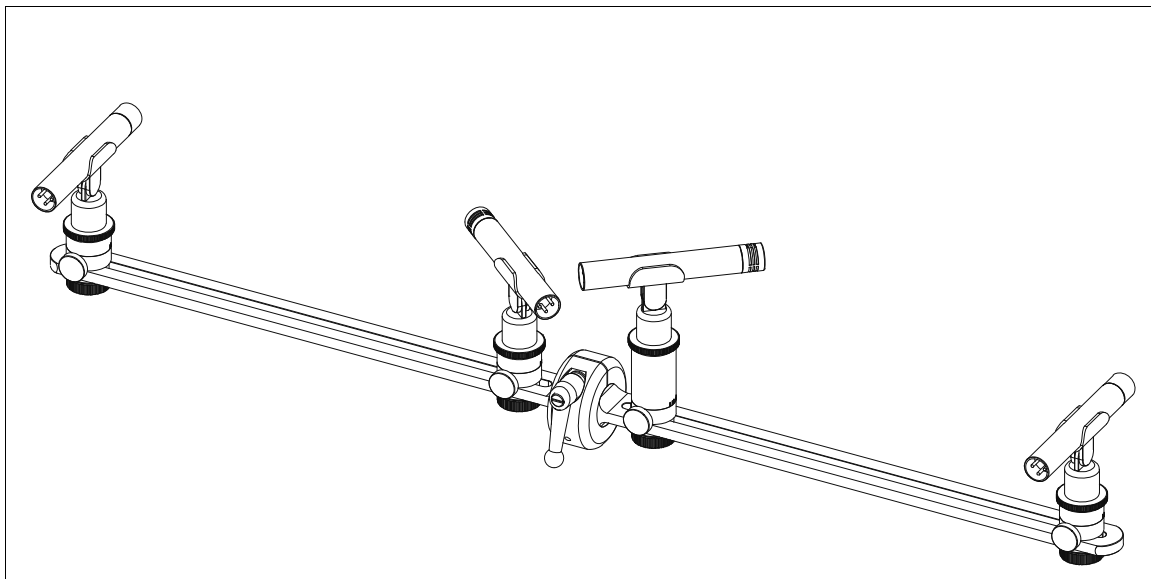

fig. 2 SB-66 with multiple mic holders

When the position lock nuts are loose the microphone angle can be adjusted by loosening the angle adjust lock screws. The angle of incidence can be adjusted with 5° precision by using the angle scale on the front of the microphone holder.

The vertical angle of the microphones can be adjusted by loosening the stand clamp locking handle and then rotating the horizontal bar to the desired angle. For reference there is a $\pm 90^\circ$ scale on the side of the stand clamp. The stand clamp locking handle is adjustable and is set from the factory to provide a good clamping force with the handle pointing downward. To adjust the angle of the handle pull the handle back from the stand clamp while rotating. When released, the handle will snap back and engage in the new position.

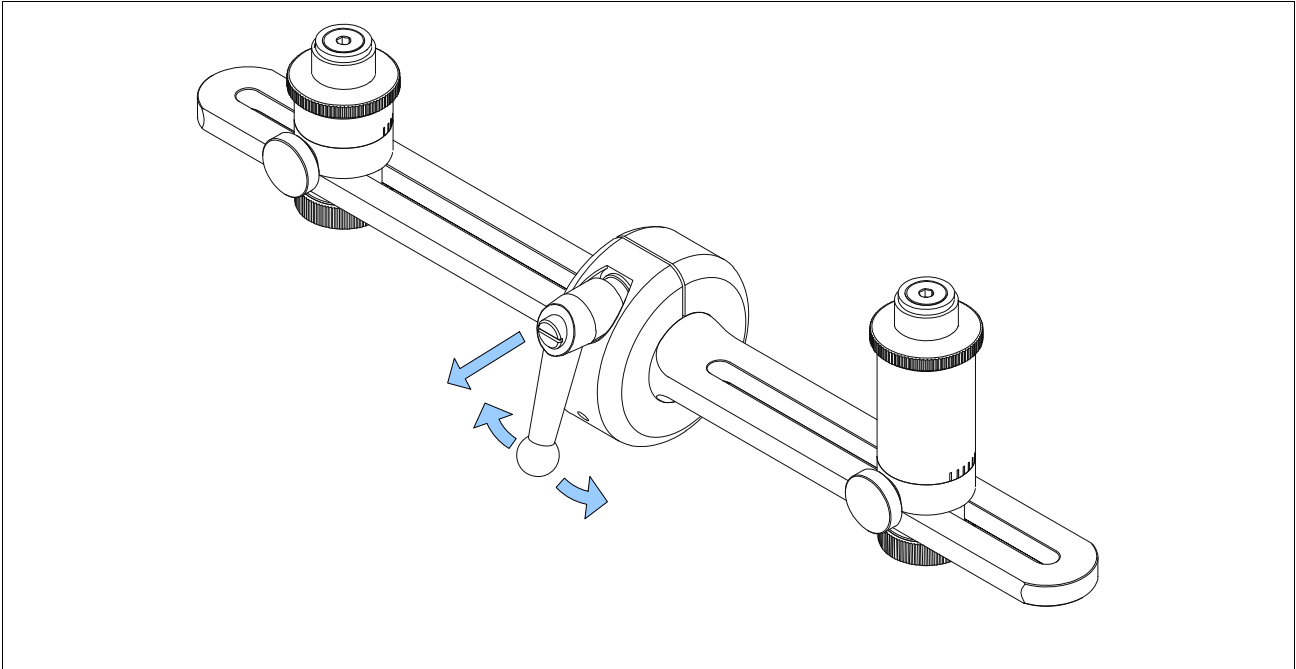

fig.3 Spacebar vertical angle adjustment

Setup Procedure

1. On the mic holder assemblies, loosen the position locking nut and the angle locking screw and set the angle to 0° . Tighten both again.
2. Thread on the microphone clips for your desired microphones but do not tighten all the way. Put the microphones in the clips and while looking down on the Spacebar from above, point the mics so that they are pointing straight forward and are perpendicular to the horizontal bar. While holding the microphone in this position, turn the jam nut counter clockwise until the clip is securely locked.

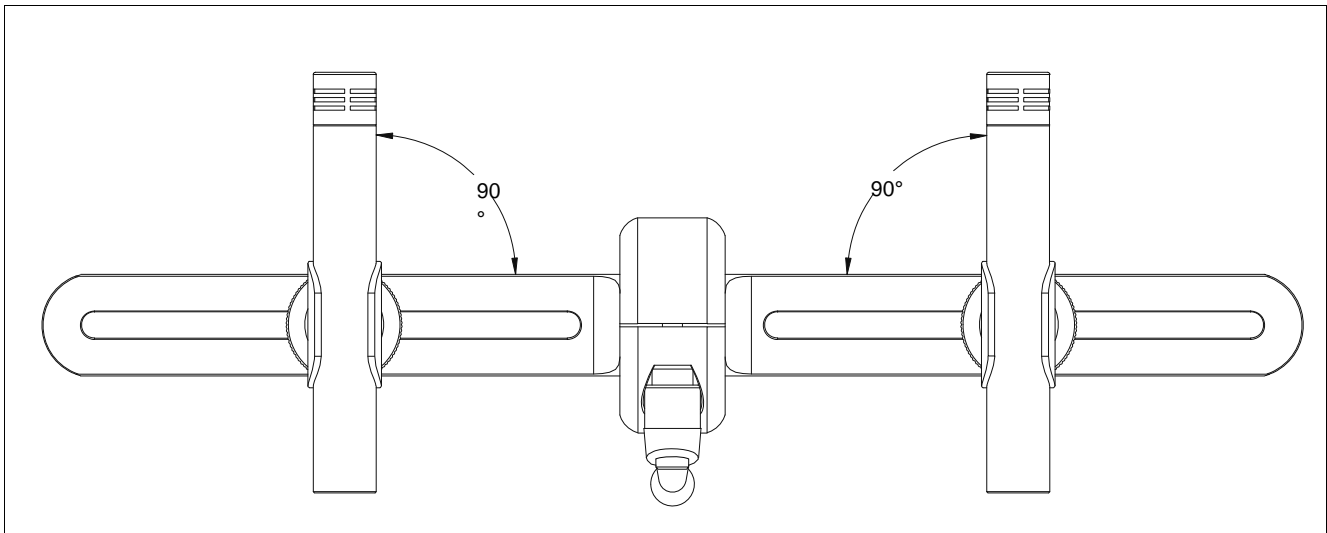

fig.4 microphone alignment, top view

3. Unlock the position locking nut and the angle lock screw and rotate the clip to the desired angle of incidence. Re-lock the angle lock screw.
4. Mount the microphones and, using a tape measure or ruler, adjust the spacing between capsules.
5. Lock the position lock nuts.

Changing the mic holder height

1. To change between the standard height mic holder and the tall mic holder, loosen and remove the position lock nut while holding the microphone holder assembly so that it does not fall.
2. Loosen the angle lock screw and remove the microphone holder body from the keyed ring.
3. Insert the desired microphone holder body into the keyed ring and tighten the angle lock screw.
4. Place the microphone holder assembly into the slot on the horizontal bar and install the Position Lock Screw to secure the assembly.

Changing the horizontal bar length

1. Refer to [fig. 5 exploded parts diagram](#) later in this manual.
2. To remove the horizontal bar, loosen the 8-32 set screw (H407) with a 5/64" hex wrench. Turn the set screw counter clock wise about 4 turns.
3. Twist the clamp handle counter-clockwise to loosen its grip and slide the horizontal bar out of the stand clamp.
4. Insert the desired horizontal bar into the stand clamp and center it but do not tighten the clamp yet.
5. Tighten the set screw with the hex wrench until the screw stops, then loosen the set screw by ¼ turn. The horizontal bar should rotate freely but not slide out of the stand clamp.

Exploded parts diagram: Spacebar SB-30

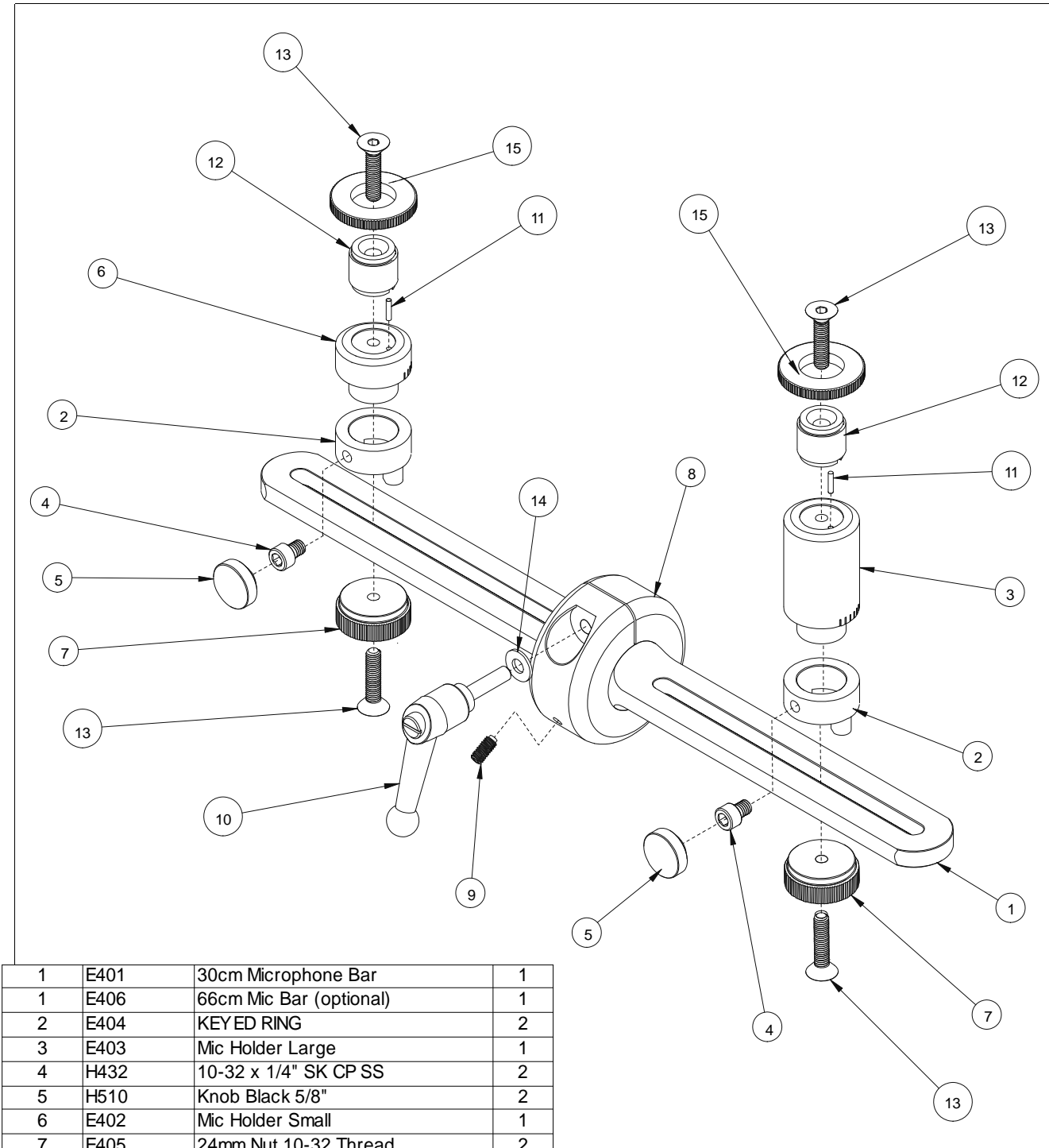

1	E401	30cm Microphone Bar	1
1	E406	66cm Mic Bar (optional)	1
2	E404	KEYED RING	2
3	E403	Mic Holder Large	1
4	H432	10-32 x 1/4" SK CP SS	2
5	H510	Knob Black 5/8"	2
6	E402	Mic Holder Small	1
7	E405	24mm Nut 10-32 Thread	2
8	E400	Round Stand Clamp	1
9	H407	8-32 x 3/8" Set Screw Pilot Point	1
10	H512	Adjustable Handle 10-32 x .78" stud	1
11	H520	Round Pin 1/16" x .3"	2
12	H514	5/8-27 Threaded Boss	2
13	H436	10-32 x 7/8" FL SC SS	4
14	H459	#10 Flat Washer Bronze	1
15	H515	5/8-27 24mm Nut	2

fig.5 SB-30 exploded parts diagram

Optional Center mount bridge SB-CMB

1. The SB-CMB center mount bridge option allows for the mounting of a center microphone. The SB-CMB mounts to the horizontal bar such that the center mic will follow any z-axis adjustments made to the Spacebar. Either the 30cm or 66cm bar can be used.
2. The SB-CMB is mounted to the horizontal bar with two 1/4-20 x 1-3/4" socket head cap screws. Use the 3/16" hex wrench included with the SB-CMB kit to tighten these screws.
3. The 24mm thumb nut clamps the mic holder bar in place. Loosening this nut allows the mic holder front to back position to be adjusted from 3cm to 13.5cm.

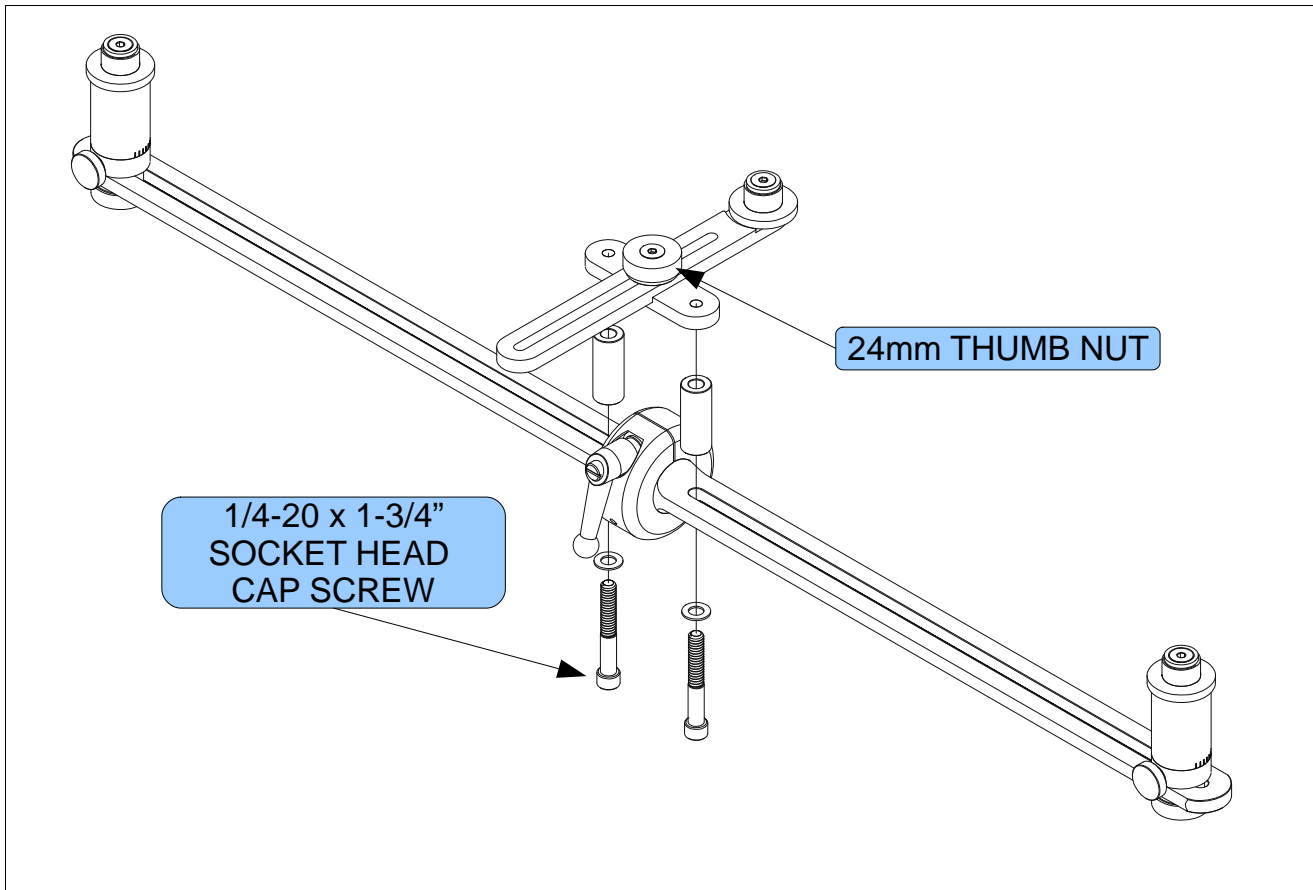
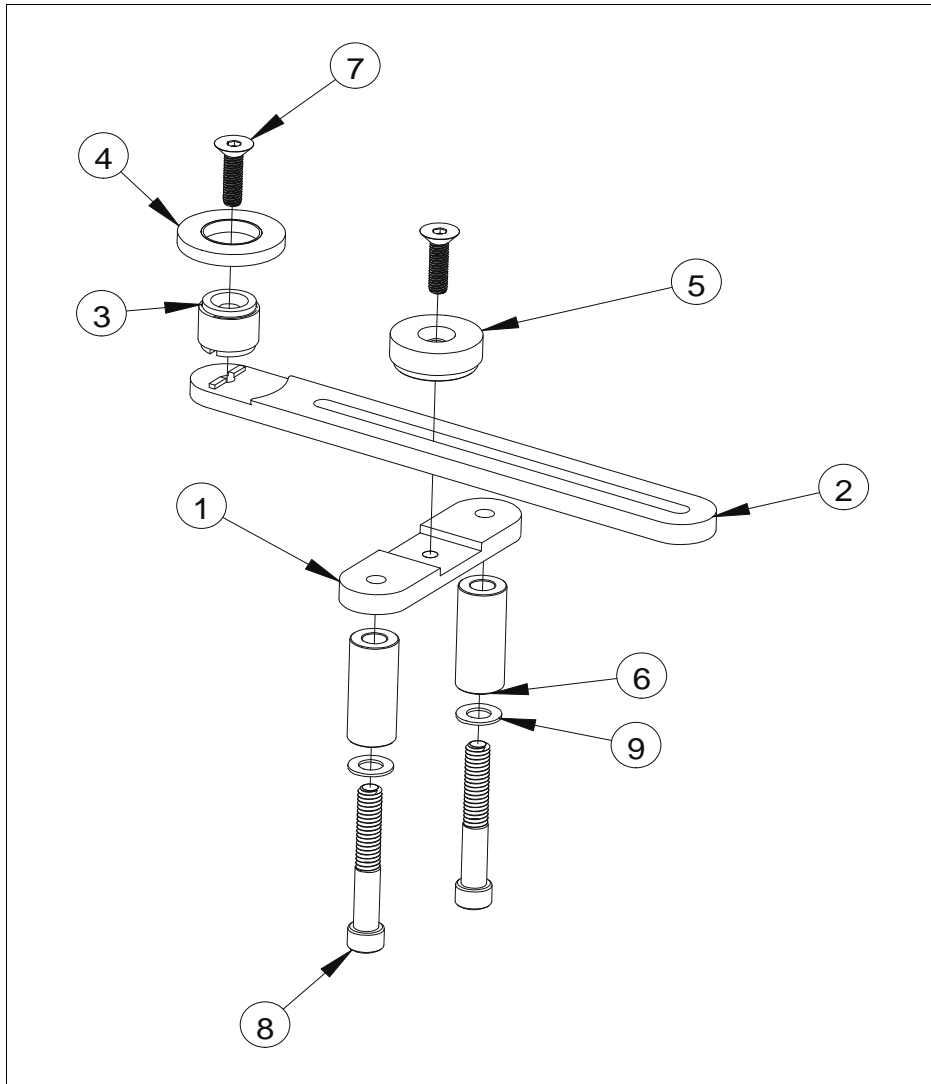

fig. 6 **SB-CMB assembly**

Exploded parts diagram: SB-CMB



ITEM NO.	Grace Part #	DESCRIPTION	QTY.
1	E427	Center Mount Bridge	1
2	E426	Center Mount Mic Holder	1
3	H514	5/8-27 Threaded Boss	1
4	H515	5/8-27 24mm Nut	1
5	E405	24mm Nut 10-32 Thread	1
6	H494	1/4" X 1" Spacer, .252" ID, 1/2" OD, Black Aluminum	2
7	H446	10-32 x 3/4" Flat Socket Head Cap Screw	2
8	H489	1/4-20 X 1-3/4" Socket Head Cap Screw Stainless Steel	2
9	H493	1/4-20 Flat Washer Stainless Steel	2

fig.7 SB-CMB exploded parts diagram

Optional Spacebar Hanging Adapter SB-HB-30/66

The Spacebar Hanging Adapter assembly consists of an aluminum wire tube that threads into the stand mount threads of the SB-30 or SB-66. A stereo (4 conductor) microphone cable is used to hang the assembly. The microphone cable is secured in the wire tube with a thumb screw that binds into the cable insulation. The microphone cable (supplied by the user) is threaded through the wire tube and then terminated to two female XLR microphone connectors. While this is a permanent arrangement that must be assembled it is very secure and ensures that there is no way that the Spacebar assembly can become detached from the cable and fall.

The Hanging Adapter assembly also comes with two monofilament yokes. These yokes are used to steer the hanging microphone array for positioning and aiming the microphones for optimal sound pickup. There are two different length yokes included. One for use with the 30cm Spacebar and one for use with the 66cm Spacebar.

The SB-HB-30/66 includes the following:

1. Hanging wire tube assembly
2. 2 pc. Monofilament yoke. (large for SB-66 and small for SB-30)
3. 2 pc. 6-32 x 3/8" button head cap screw

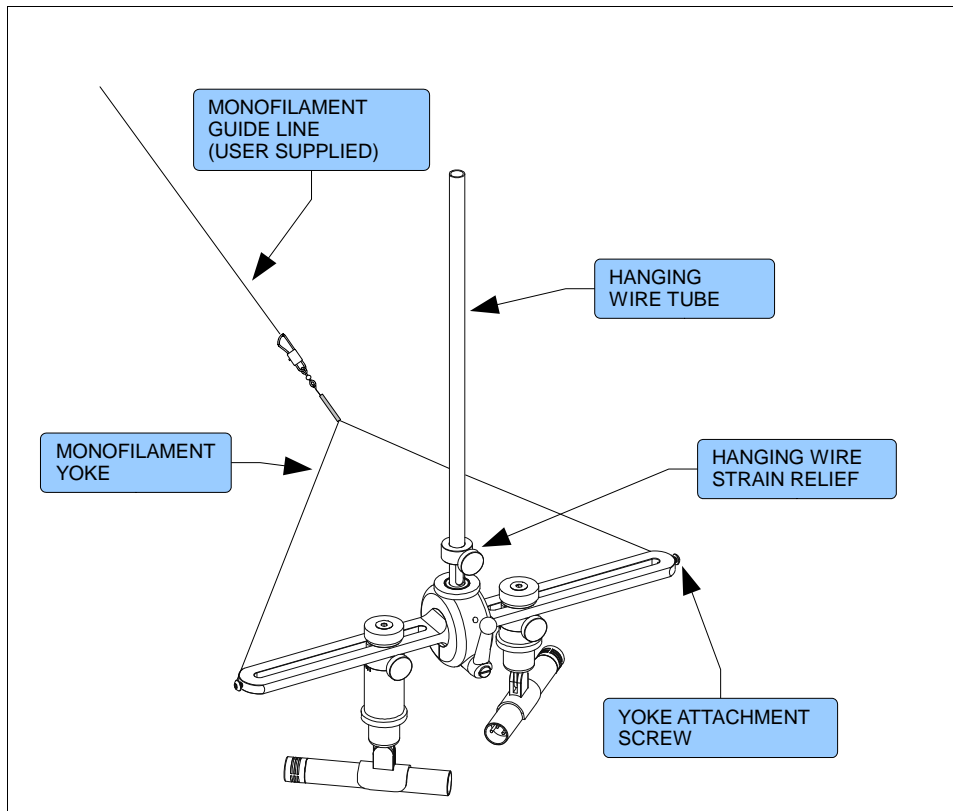

fig. 8 **SB-HB Diagram**

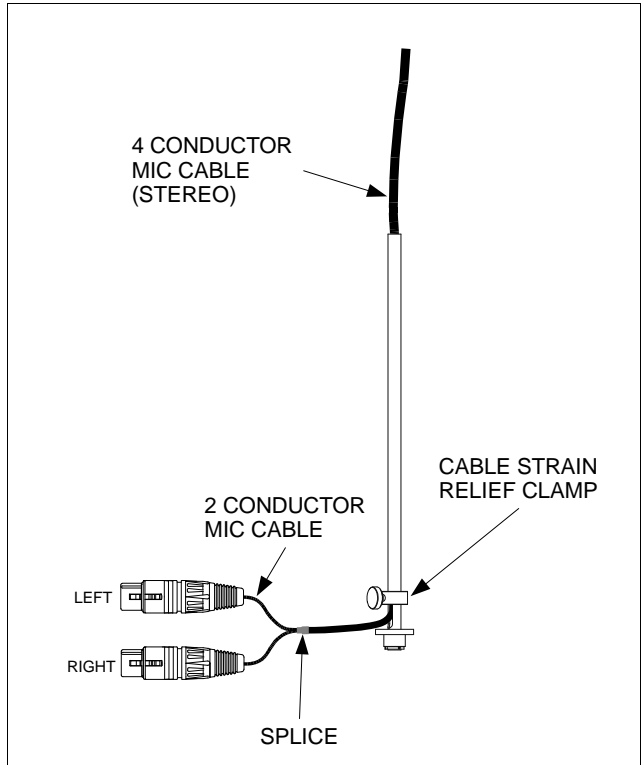

fig. 9 Hanging Adapter Wiring Detail

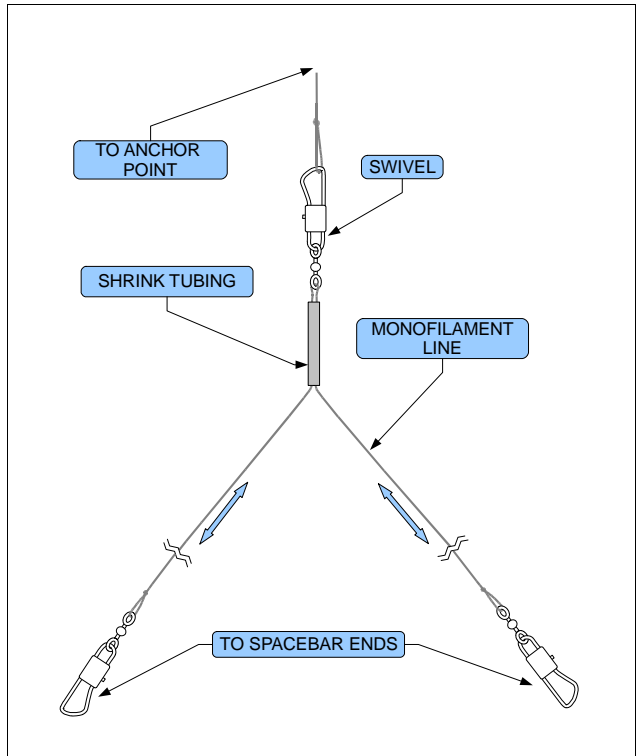

fig. 10 Hanging Adapter Monofilament Yoke

Spacebar Hanging Adapter Setup Procedure

1. Thread the 4 conductor microphone cable through the wire tube and have it exit through the oval opening. We recommend using the Canare L-4E6S / L-4E5C Star Quad cable for this application. Refer to fig. 9 'Hanging Adapter Wiring Detail'.
2. Pull enough of the wire through the oval opening to facilitate splicing to a two conductor microphone cable for the Left and Right lead wires.
3. Splice on the Left and Right lead wires and then terminate to the female XLR connectors.
4. Next thread the wire tube assembly into the stand mount hole on the Spacebar.
5. Establish how much wire loop will be needed for the wires to reach the microphones and then tighten the thumb screw so that it binds into the wire insulation. This will secure the wire and keep it from slipping back through the wire tube.
6. Install the 6-32 x 3/8" button head screws in the ends of the bar leaving about 1/16" of thread showing.
7. Clip the swivels on the ends of the monofilament yoke to the 6-32 button head screws. The system is now ready to be hung.



Caution: Use extreme care in securing the hanging cable. A falling Spacebar assembly with microphones can cause severe injury or death.

Revision History

Rev.	Description	Date	Initials
A	Initial release	01/30/09	MBG
B	Changed wording in "Changing horizontal bar length" Added SB-CMB instructions.	10/03/09	MBG
C	Added SB-HB to manual	08/09/10	EDG