

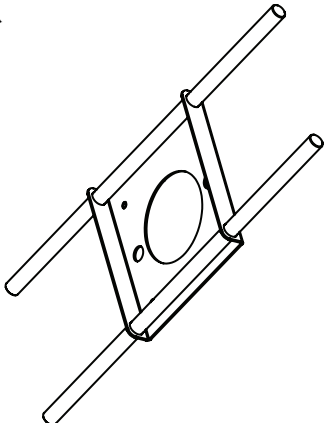

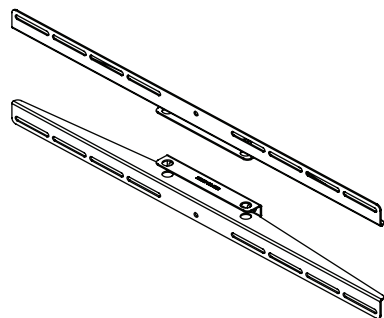

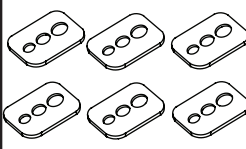

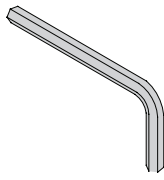

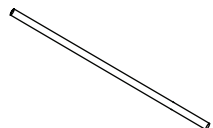
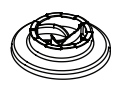
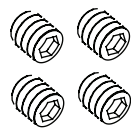

UAP Assembly Instructions

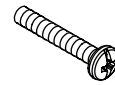
The UAP was designed to fit flat panel mounting patterns up to 600mm x 400mm. It will adapt to any Premier Mount with a 100 x 100 vesa mounting pattern.

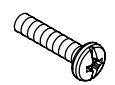
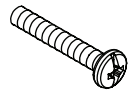
		 <p>Adapter Plate (Qty 1)</p>		 <p>Adapter Arms (Qty 2)</p>		 <p>Universal Washers (Qty 6)</p>		 <p>M3 Allen Wrench (Supplied)</p>					
				 <p>Thread Depth Indicator (Supplied)</p>		 <p>Universal Spacers (Qty 30)</p>							
 <p>M6 Set Screw (Qty 4)</p>		 <p>M4 x 8mm Combo Screw (Qty 4)</p>		 <p>M4 x 10mm Combo Screw (Qty 6)</p>		 <p>M4 x 16mm Combo Screw (Qty 6)</p>		 <p>M4 x 25mm Combo Screw (Qty 6)</p>		 <p>M4 x 30mm Combo Screw (Qty 6)</p>		 <p>M5 x 16mm Combo Screw (Qty 6)</p>	
 <p>M5 x 25mm Combo Screw (Qty 6)</p>		 <p>M5 x 30mm Combo Screw (Qty 6)</p>		 <p>M6 x 16mm Combo Screw (Qty 6)</p>		 <p>M6 x 25mm Combo Screw (Qty 6)</p>		 <p>M6 x 30mm Combo Screw (Qty 6)</p>		 <p>M8 x 16mm Combo Screw (Qty 6)</p>		 <p>M8 x 25mm Combo Screw (Qty 6)</p>	
 <p>M8 x 30mm Combo Screw (Qty 6)</p>		 <p>M4 x 45mm Combo Screw (Qty 6)</p>		 <p>M5 x 45mm Combo Screw (Qty 6)</p>		 <p>M6 x 45mm Combo Screw (Qty 6)</p>		 <p>M8 x 45mm Combo Screw (Qty 6)</p>		 <p>Screwdriver (Not Supplied)</p>			

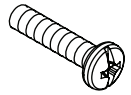
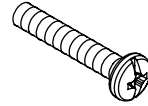
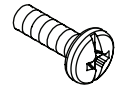
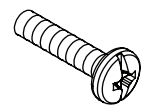
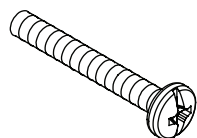
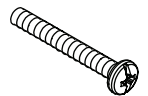
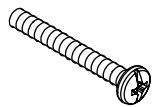
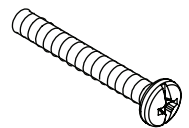
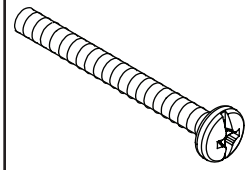
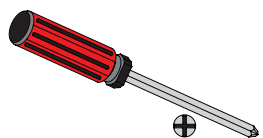
Adapter Arms Orientation

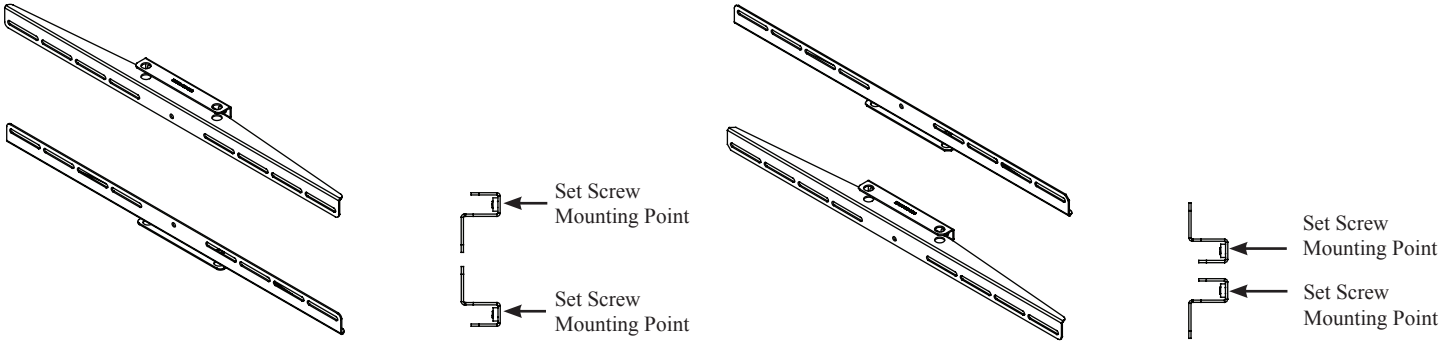
**NOTE**

The illustration to the left shows the two placement positions for the mounting arms. Either configuration is acceptable and is dependant upon your flat panel's mounting hole pattern

Determining the Mounting Hardware

Step 1. Insert the thread depth indicator (supplied) through the thread inserts found on the back of the flat panel.

Step 2. Using a pencil, mark the depth of the thread insert on the thread depth indicator (Figure 2).

Step 3. Compare and verify the depth of the remaining thread inserts.

Step 4. Locate the correct diameter screw for the thread insert.

Step 5. Compare your thread depth indicator marking to the screw length.

**NOTE**

If your selected screw is longer than the marking on the thread depth indicator, do not use this screw. The screw length must not bypass the marking. If so, select another screw size (Figure 2 and 3) until you find the screw the comes closest to your mark without going past the marking.



When using the universal spacers in the installation, make sure to account for the appropriate spacing depth when measuring with the thread depth indicator. Using the universal spacers will change the overall length of the hardware used.

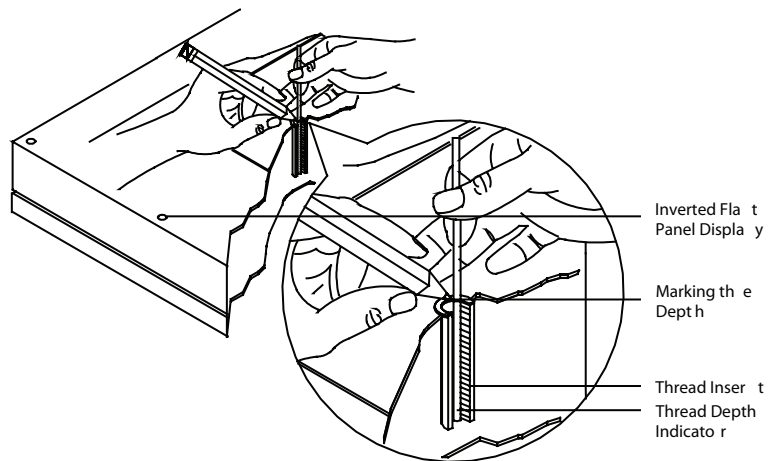

Figure 1

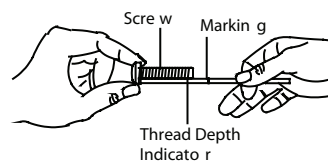

Figure 2

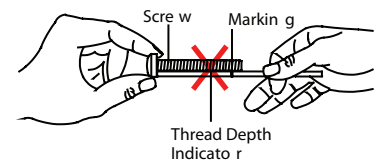
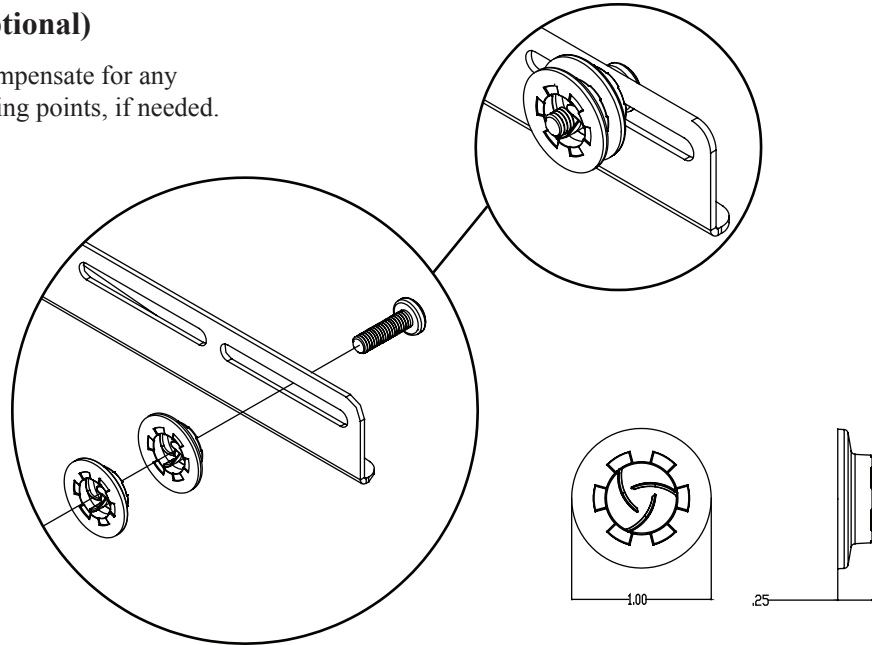

Figure 3



Universal Spacers Installation (optional)

NOTE Use the universal spacers to compensate for any indentations or recessed mounting points, if needed.



The universal spacer may be stacked five (5) high, for a total stacking height of 1-1/4". The universal spacers must be stacked in the direction shown above. The universal spacers must be placed between the mounting bracket and the flat panel. The universal spacer will fit M4, M5, M6 and M8 screws sizes.

UAP Assembly

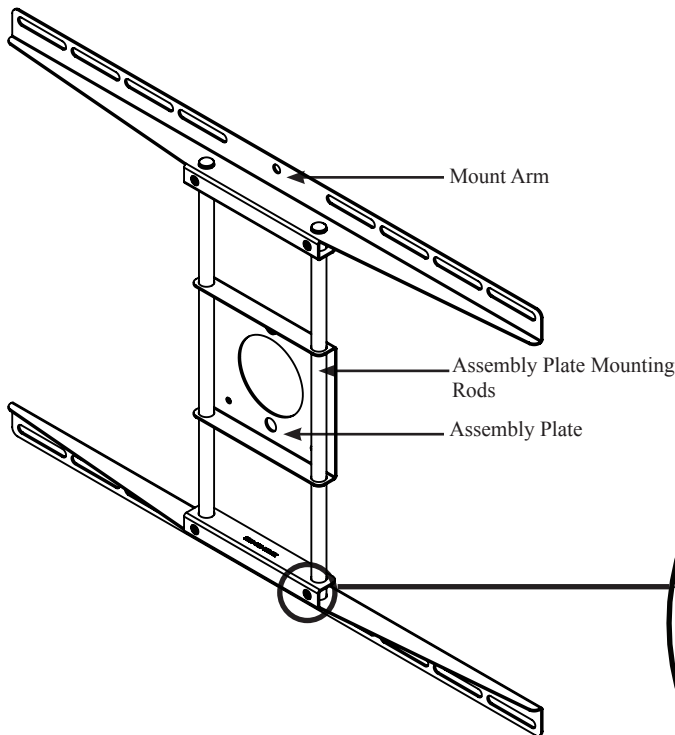

Step 1. Slide each mount arm onto the assembly plate mounting rods.

Step 2. Insert four (4) M6 set screws into the mount arms (two per arm). Use the M3 Allen wrench (supplied) to tighten the set screws.

NOTE These screws should remain loose until the adapter plate is attached to the display.

NOTE Please refer to the manufacturers' installation instructions to mount the UAP to the purchased flat panel mount.

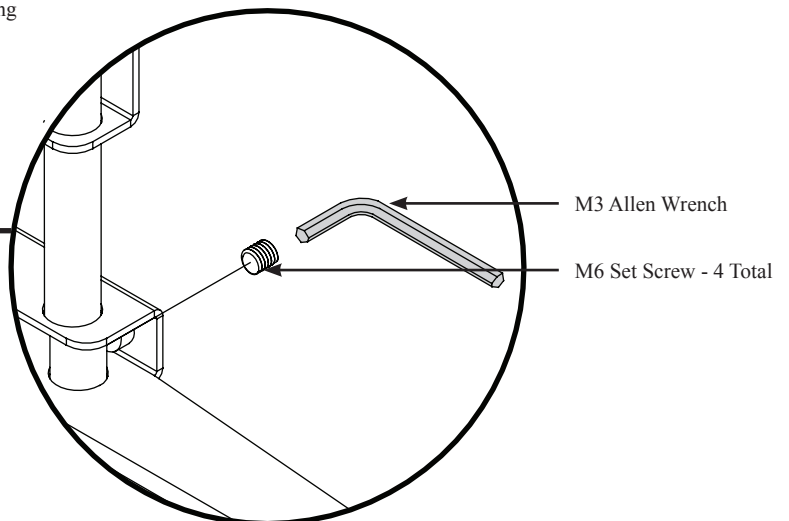

Universal Washer Installation

The universal washer will fit M4, M5 M6 and M8 hole patterns that your flat panel requires.

EXAMPLE: If your flat panel uses M8 screws, use the M8 mounting points.



Pre-install the mounting screws, spacers and washers. Once mounted, push down to eliminate movement from the bracket. Then proceed to tighten the rest of the hardware. Repeat this process for the installation of the remaining mounting bracket.

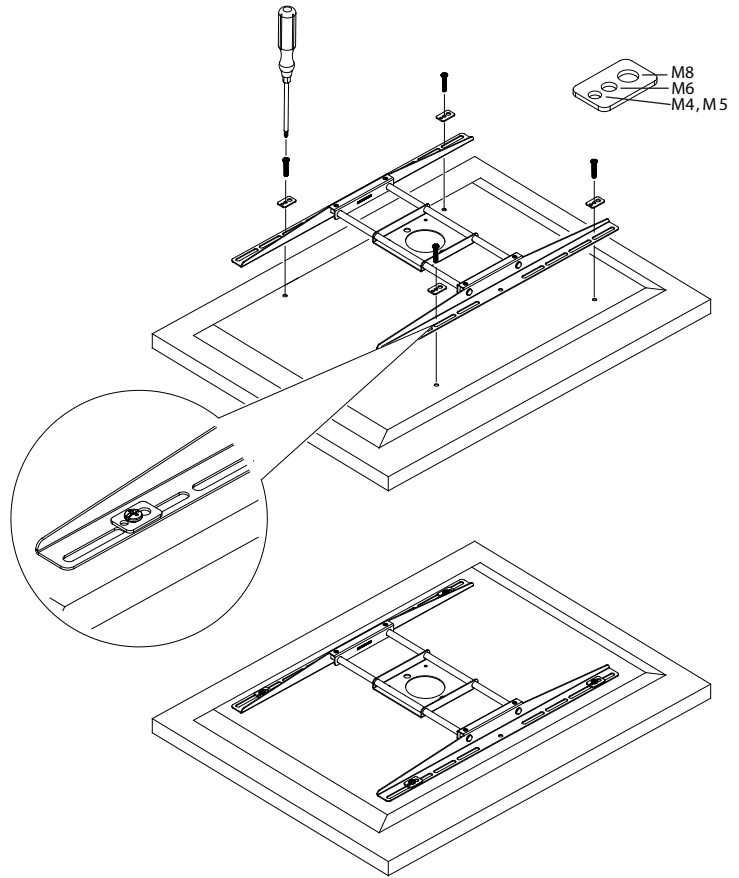

Attaching the Flat Panel with the Adapter Plate

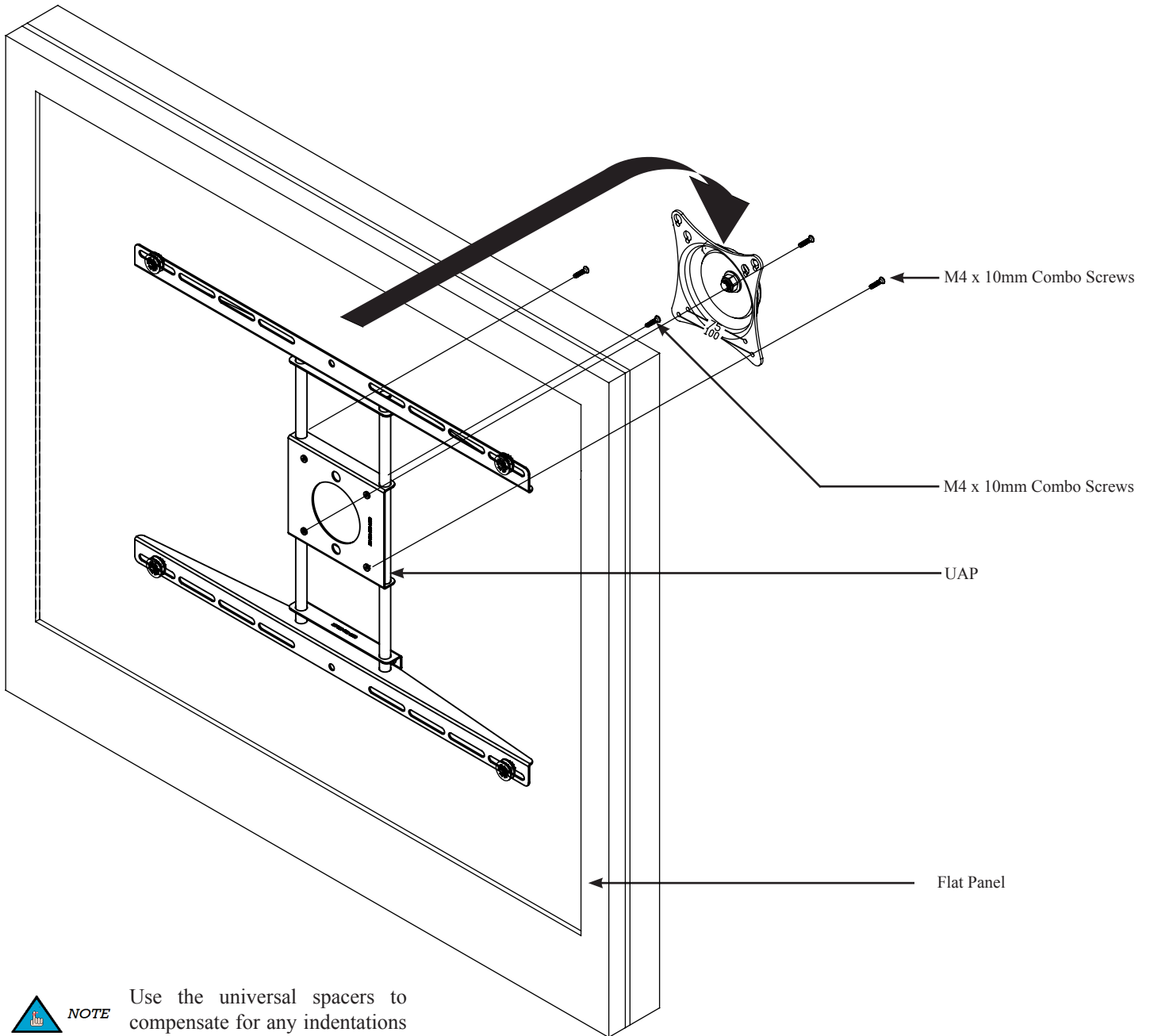

NOTE

Use the universal spacers to compensate for any indentations or recessed mounting points, if needed.



NOTE

It is recommended that the flat panel rest on a soft and flat surface while assembling the mount.

- Step 1.** Fasten, to 1/2 the depth of the screws, two (2) M4 x 10mm combo screws to the top two mounting points on the UAP.
Do not completely tighten these screws at this time
- Step 2.** Insert the head of the screws through the keyhole slots on the flat panel mount.
- Step 3.** Insert and tighten the bottom two (2) M4 x 10 combo screws to secure the UAP to the flat panel mount.
- Step 4.** Use a screwdriver to tighten all mounting hardware.



Do not over-tighten the mounting screws.