

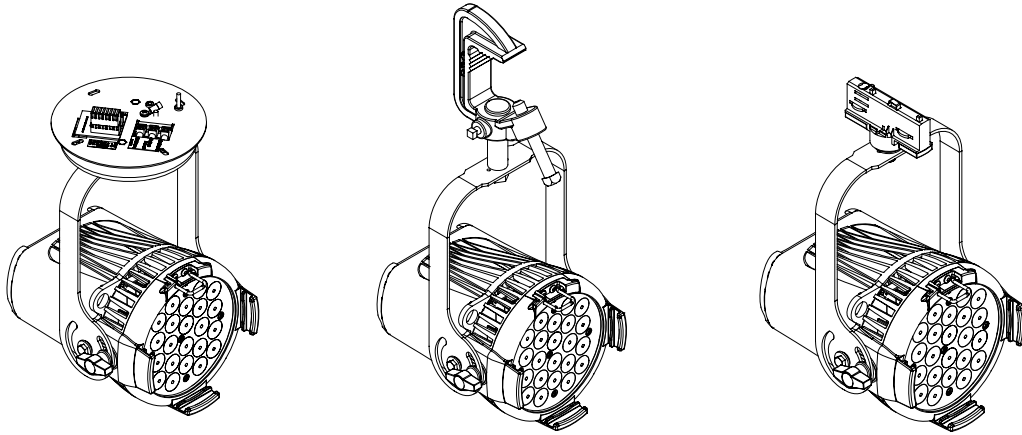

100V 115/120V 230/240V

Desire® Series



GENERAL INFORMATION

ETC's Selador Desire D22 luminaire puts the x7 Color System™ into a compact, round washlight. Highly efficient primary lenses and careful color choices make the D22 fixture ideal for stage, studio, architecture and anywhere vibrant color and high intensity are requirements. The Selador® x7 Color System produces the widest range of spectrally-balanced saturated and tinted color choices available, while the static-white options provide an impressive punch. D22's rugged die-cast enclosure, noiseless fan-free operation, multiple lens options, convenient size and advanced user interface make it an ideal addition to the Desire family of LED luminaires.

D22 LED ARRAY

D22 fixtures are available with any one of the following arrays (not interchangeable) to best suit the intended application.

- D22 Lustr+™: Optimized array with six colors plus, high-intensity white LEDs to create an ideal wash fixture for full-range color
- D22 Studio Daylight: Contains twenty-two 5600K LEDs for high-intensity, non-variable cool-white output
- D22 Studio Tungsten: Contains twenty-two 3000K LEDs for high-intensity, non-variable warm-white output
- D22 Studio HD: Combines warm white and cool white LEDs for variable-color-temperature mixing. Added to this are carefully chosen colors from the Selador x7 Color System to fill in the white LED spectral gaps, providing the richest variable-white light possible in an LED fixture.

D22 MOUNTING CONFIGURATIONS

D22 fixtures are available in three different mounting options to fit any installation:

- D22 Portable: Standard yoke-mount hardware; power lead with Edison connector and DMX in/thru connectors
- D22 Install Canopy: Standard yoke-mount and canopy hardware; power lead with bare ends; and a permanent, single DMX in/thru cable
- D22 Track-Yoke: Track adapter and a single, permanent cable for both power and DMX in

ORDERING INFORMATION

Selador D22

MODEL	DESCRIPTION
SELD22L	D22 Lustr+ wash fixture
SELD22D	D22 Studio Daylight wash fixture
SELD22T	D22 Studio Tungsten wash fixture
SELD22H	D22 Studio HD wash fixture

Note: D22 luminaires ship with hanging yoke. See page 2 for connector options. C-clamps are not included.



SPECIFICATIONS

GENERAL

- 22-LED color-mixing wash fixture (Lustr+™)
- 22-LED variable white-light fixture (Studio HD)
- 22-LED static cool- or warm-white wash fixture (Studio Tungsten and Studio Daylight)
- ETL listed general purpose lighting
- IP20-rated for indoor use
- DMX in/thru for easy setup (no DMX thru on D22 Track)
- User-friendly control interface with multiple modes and fixture settings
- Permanent power input cable connected

PHYSICAL

- Rugged die-cast all-metal housing
- Easy access slots for secondary lenses and 5.5" accessories
- Available in black (standard), white, silver (optional) or custom colors (contact factory)
- Hanging yoke standard
- DMX512 in/thru via five-pin XLR connectors (D22 Portable only)

ELECTRICAL

- 100VAC to 240VAC 50/60Hz universal power input
- Requires power from a non-dim source
- Inrush
 - 120V: 17V
 - 240V: 25V

LED*

- 50,000-hour LED life (50,000 hours at 70% intensity)
- 22 Luxeon® Rebel LED emitters

*See additional LED notes on page three

COLOR (LUSTR+ AND STUDIO HD ONLY)

- Exclusive x7 *Color System*™ seven-color LED array (Lustr+)
- Unique mix of x7 colors and warm and cool LEDs (Studio HD)
- Beautifully illuminates skin tones and other objects for natural appearance and high color rendering
- Broad-spectrum color interacts seamlessly with conventional sources
- Exclusive, optional red-shift option emulates tungsten dimming performance

OPTICAL

- Primary field angle of 21°
- Secondary lenses available for multiple beam spread options
- Refer to accessories charts for lenses available

CONTROL

- Multiple control options, including RGB, strobe, and console-free Master/Slave mode
- See DMX Control Table for additional information
- 15-bit virtual dimming engine provides smooth, high-quality theatrical fades, and minimizes color shift during dimming
- RDM functionality for address and setting changes

THERMAL

- Ambient operating temperature of -4° to 104°F (-20° to 40°C)
- Active electronic thermal management for droop-free operation
- Noiseless, fan-free convection cooling for acoustically sensitive installations
- Fixture is designed for continuous operation up to 104°F (40°C) ambient temperature and requires free flow of air around fixture housing

ADDITIONAL ORDERING INFORMATION

Connector Options

Use information below to order input with factory-fitted connectors

MODEL	DESCRIPTION
n/a	Portable with Edison connector
-I	Install Canopy Mounting
-T	Track Mounting

Fixture Accessories

MODEL	DESCRIPTION
SELD22BD	Barn door (Use only as a flexible top hat to diminish aperture glare. Not for beam shaping.)
SELD22CF	5.5" Color Frame (use for round and oblong lenses)
SELD22ECL	Egg Crate Louver
SELD22HS	Half-Shield
SELD22FSY	Yoke with floor stand attachment
400CC	C-Clamp (does not ship with fixture)
400SC	Safety Cable (32")

Note: All model numbers above are for black accessories. Add -1 for white or -5 for silver. Custom colors are available upon request.

ADDITIONAL ORDERING INFORMATION

Secondary Lens Options

MODEL	DESCRIPTION: The following lenses are cut for D22 fixtures and create round, linear or oblong field patterns as described below. These lenses are not sized for use in Selador® Classic (Vivid-R™, Lustr®, Paletta™, etc.) fixtures.	
Narrow Linear Field	Note: This is the same material as Selador Classic lenses	
SELLVN-D22	Very Narrow lens (narrow linear field)	Linear lenses may be combined to create desired field size, i.e. 40° X 60°
SELLN-D22	Narrow lens (narrow linear field)	
SELLM-D22	Medium lens (narrow linear field)	
SELLW-D22	Wide lens (narrow linear field)	
SELLXW-D22	Extra Wide lens (narrow linear field)	
Round Field		
SELRVN-D22	Very Narrow lens (round field)	
SELRN-D22	Narrow lens (round field)	
SELRM-D22	Medium lens (round field)	
SELRW-D22	Wide lens (round field)	
SELRXW-D22	Extra Wide lens (round field)	
Oblong Field		
SELON-D22	Narrow lens (oblong field)	
SELOM-D22	Medium lens (oblong field)	
SELOW-D22	Wide lens (oblong field)	

http://www.etconnect.com/docs/docs_downloads/miscdocs/Desire vs PAR EA revB.pdf

Typical Lens-Field Profiles

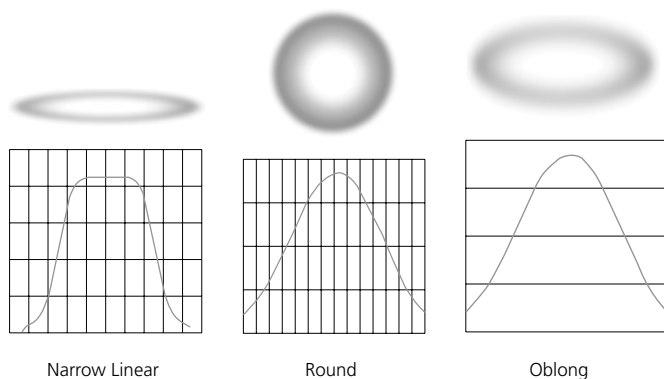

Power Consumption at Full Intensity

MODEL	VOLTAGE (V)	CURRENT (A)	WATTS
D22	120/240	0.47	56.5

NOTES ABOUT LED LUMINAIRES

All LED sources experience light-output reduction and some color shift over time. LED output will vary with thermal conditions, which can be affected by ambient temperatures and orientation. See the D40 Ambient Temperature and Power Budgeting Guide for more details. Based on the LED manufacturer's B50 L70 specification, a Selador luminaire will achieve ~70% of its initial output after 50,000 hours of typical usage. In individual situations, LEDs will be used for different durations and at different levels. This can eventually lead to minor alterations in color performance, necessitating slight adjustment to presets, cues or programs.

CRI AND CQS RATINGS

Desire fixtures were evaluated for CRI and CQS performance using measured output spectrum and optimized mix solutions for the best spectral match to black body sources at 3200K and 5600K.

Fixture	CRI	CQS	Color Fidelity	Duv
D22 Lustr+ at 3200K	86	88	88	0.000
D22 Lustr+ at 5600K	93	92	90	0.000

The D22 luminaire provides excellent color rendering to the eye, particularly at higher color-temperature settings such as 5600K. A Duv rating of 0.000 indicates that the color mix used is exactly on the black body line, with no green or magenta tint.

CONTROL OPTIONS

User settings on D22 fixtures allow multiple operational modes and settings for either console operation via DMX protocol or stand-alone operation. The expanded LCD display provides easy navigation to all possible settings and options. Some of them are:

- Multiple DMX choices, ranging from a simple RGB profile – which effectively controls all seven LED colors via three channels – to nine-channel ‘direct’ color and intensity control
- Multiple dimming curve options
- Preset colors and sequences for stand-alone (no console required) operation
- White-point selection: White-light and color behavior based on a specific-color-temperature white light, i.e. 3200K, 5600K, etc.
- Loss of data behavior options: Instant off, hold last look for two minutes, etc.
- Output modes: Three output options that offer the user a choice between maximum output and maximum consistency

See the user manual for a complete explanation of all of the control settings and options for the D22.

Quick Setups

To assist in managing the numerous control and fixture behavior choices, five combinations of operational settings are available to quickly get started. These settings are specifically created for different applications and are easily accessible at the fixture display. Each setting can then be modified as required to take advantage of all of the possible control features.

Setting Title	Profile	Description	Typical Features*
General	Direct	Factory default: For general-purpose use, including interior architectural applications	<ul style="list-style-type: none"> • Standard dimming curve • Regulated output for color consistency
Stage	HSI Plus 7 Enabled	Theatrical lighting: Duplicates the color and dimming behavior of tungsten stage lighting fixtures.	<ul style="list-style-type: none"> • Incandescent dimming curve • Regulated output for color consistency • 3250K white-point setting
XT Arch	HSI	Exterior architectural lighting: Provides a high degree of color consistency in high ambient-temperature environments.	<ul style="list-style-type: none"> • Standard dimming curve • Protected output • 3200K white-point setting
High Impact	RGB	Event lighting: Enables quickest response, simple RGB control and strobe channel for maximum effect usage	<ul style="list-style-type: none"> • Quick dimming curve • Boost mode for maximum intensity • 5600K white-point setting
Studio	Studio	Studio factory default: Enables three-parameter control of white light (intensity, white point, and tint) via DMX from a console or from the fixture display – without a console	<ul style="list-style-type: none"> • Linear dimming curve • Regulated output mode for color consistency

*See user manual for complete list of features for each Quick Setup

CONTROL OPTIONS

DMX Input Channel Profiles

DMX Profile	DMX Channels	Channel Assignments	Notes
Direct	9	1 – Red 2 – Orange (white for Lustr+) 3 – Amber 4 – Green 5 – Cyan 6 – Blue 7 – Indigo 8 – Intensity 9 – Strobe	Direct control of each individual color with a separate master-intensity channel. Color calibration of LEDs is not active in this mode. The nine-channel profile will produce the highest-quality color crossfades.
HSI	5	1 – Hue (coarse) 2 – Hue (fine) 3 – Saturation 4 – Intensity 5 – Strobe	High-resolution hue (two channels), saturation, and intensity control. HSI mode will produce arbitrary color crossfades around the color space.
HSIC	6	1 – Hue (coarse) 2 – Hue (fine) 3 – Saturation 4 – Intensity 5 – Strobe 6 – Color Point (CCT)	High-resolution hue, saturation and intensity control as above, with the addition of a color-point channel to adjust the color temperature of the fixture in both white light and color. Color crossfade performance is the same as HSI.
RGB	5 (Ch. 4 not used)	1 – Red 2 – Green 3 – Blue 4 – n/a 5 – Strobe	Effectively addresses all seven colors via three channels of control. RGB profile will produce medium-quality color crossfades
Studio	3	1 – Intensity 2 – Color Point (CCT) 3 – Tint	Controls fixture as a white-light unit. If for example, no DMX console input is present, the fixture can be adjusted for these three parameters on the UI at the back of the unit.
Additional profile options			
Plus 7		Seven additional color-control channels are available in RGB, HSI, HSIC, and Studio profile settings. For example, HSI with ‘Plus 7’ enabled becomes a 14-channel profile:	
		1 – Hue (coarse) 2 – Hue (fine) 3 – Saturation 4 – Intensity 5 – Strobe 6 – n/a 7 – Plus 7 Control on/off 8 – Red 9 – Orange (white for Lustr+) 10 – Amber 11 – Green 12 – Cyan 13 – Blue 14 – Indigo	<p>The desired color and intensity is achieved by using the HSI or RGB channels.</p> <p>Placing channel seven at a value over 51% gives the fixture a 14-channel profile.</p> <p>Channels 8-14 represent the native colors of the fixture and allow the operator to adjust individual color channels to fine tune the color output.</p>
Strobe		Variable strobe control: 0% is no strobe. The fixture output will strobe more rapidly as the strobe channel value approaches 100%.	

CONTROL OPTIONS

Studio Daylight and Studio Tungsten (only)

Quick Set-Ups

Setting Title	Profile	Description	Typical Features
Studio	Studio	Enables control of intensity from luminaire UI; no console required	<ul style="list-style-type: none"> • Linear dimming curve • Regulated output for intensity stability
Single Channel	Direct	For general purpose architectural use	<ul style="list-style-type: none"> • Standard dimming curve • Regulated output for color consistency
Stage	Direct	Matches conventional luminaire performance	<ul style="list-style-type: none"> • Incandescent dimming curve • Regulated output

DMX Input Channel Profiles

DMX Profile	DMX Channels	Channel Assignments	Notes
Studio	3	1 – Intensity 2 – Strobe 3 – Fan Control (D60 only)	Control of parameters is also enabled from the luminaire's user interface. No console required.
Direct	3	1 – Intensity 2 – Strobe 3 – Fan Control (D60 only)	

PHOTOMETRICS

D22 Lustr+™

Mode	Degree	Candela	Field Lumens	Beam Lumens	Lumens Per Watt
Boost - Cold	21°	49,151	1,681	707	32
Regulated	21°	43,669	1,499	629	31

Metric Conversions: For meters, multiply feet by .3048
For lux, multiply foot candles by 10.76

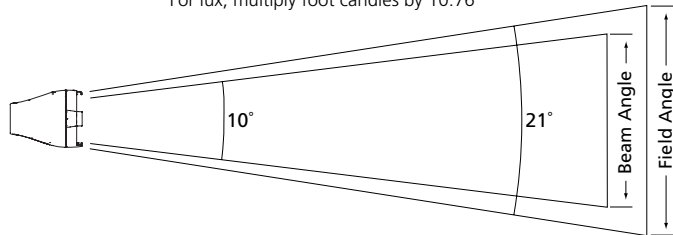

Throw Distance (d)	10'	15'	20'	30'	209
	3.0m	4.6m	6.1m	9.1m	63.7m
Field Diameter	3.7'	5.6'	7.4'	11.1'	-
	1.1m	1.7m	2.3m	3.4m	-
Illuminance (fc)	437	194	109	48.6	
Illuminance (lux)	4,704	2,091	1,176	523	

For field diameter at any distance, multiply distance by .301
For beam diameter at any distance, multiply by 0.145

Cosine Candela Plot

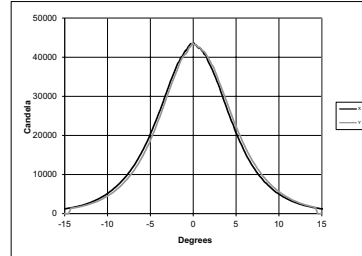

Iso-Illuminance Diagram (Flat Surface Distribution)

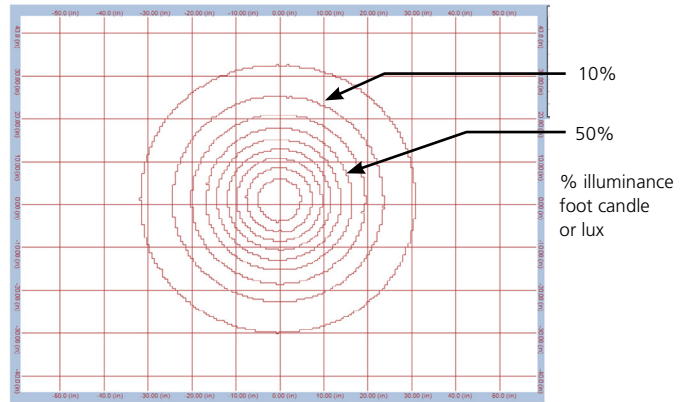

D22 Studio Daylight

Mode	Degree	Candela	Field Lumens	Beam Lumens	Lumens Per Watt
Boost - Cold	22°	49,808	2,722	1,099	51
Regulated	22°	46,151	2,533	1,031	50

Metric Conversions: For meters, multiply feet by .3048
For lux, multiply foot candles by 10.76

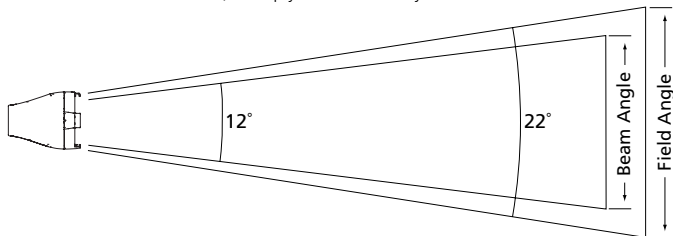

Throw Distance (d)	10'	15'	20'	30'	214.8'
	3.0m	4.6m	6.1m	9.1m	65.5m
Field Diameter	4.8'	7.3'	9.7'	14.5'	-
	1.5m	2.2m	2.9m	4.4m	-
Illuminance (fc)	462	205	115	51.3	
Illuminance (lux)	4,968	2,208	1,242	552	

For field diameter at any distance, multiply distance by .390
For beam diameter at any distance, multiply by 0.198

Cosine Candela Plot

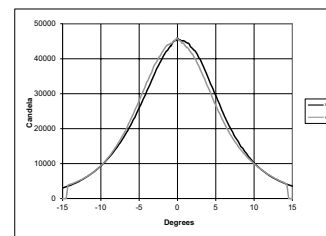

Iso-Illuminance Diagram (Flat Surface Distribution)

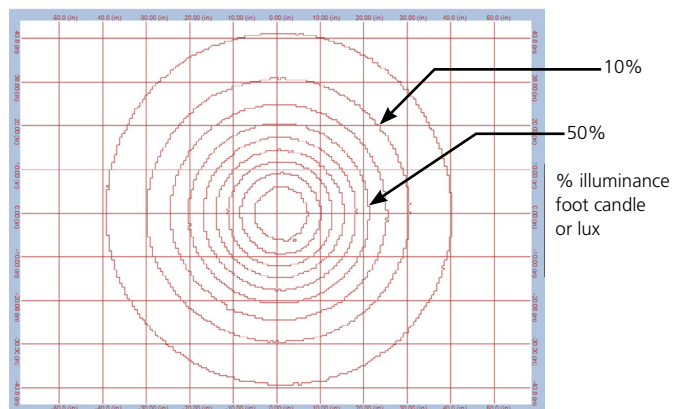

PHOTOMETRICS

D22 Tungsten

Mode	Degree	Candela	Field Lumens	Beam Lumens	Lumens Per Watt
Boost - Cold	24°	41,656	2,210	1,031	41
Regulated	24°	39,502	2,096	978	41

Metric Conversions: For meters, multiply feet by .3048
For lux, multiply foot candles by 10.76

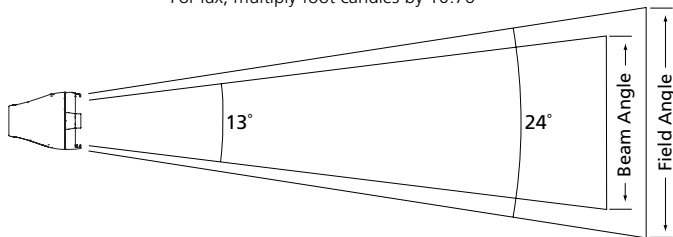

Throw Distance (d)	10'	15'	20'	30'	198.8
	3.0m	4.6m	6.1m	9.1m	60.6m
Field Diameter	4.5'	6.8'	9.0'	13.5'	-
	1.4m	2.1m	2.7m	4.1m	
Illuminance (fc)	395	176	99	43.9	
Illuminance (lux)	4,252	1,890	1,063	472	

For field diameter at any distance, multiply distance by .414
For beam diameter at any distance, multiply by 0.189

Cosine Candela Plot

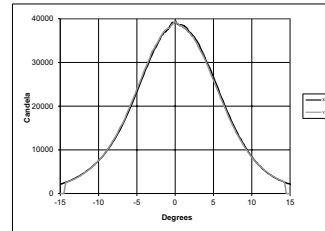

Iso-Illuminance Diagram (Flat Surface Distribution)

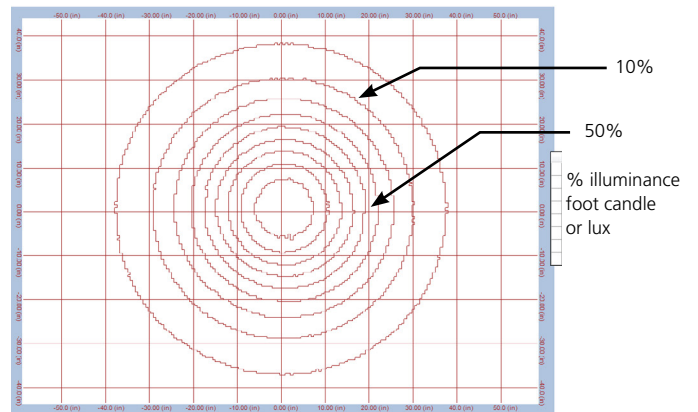

D22 Studio HD

Mode	Degree	Candela	Field Lumens	Beam Lumens	Lumens Per Watt
Boost - Cold	21°	44,555	1,731	715	33
Regulated	21°	32,166	1,247	507	31

Metric Conversions: For meters, multiply feet by .3048
For lux, multiply foot candles by 10.76

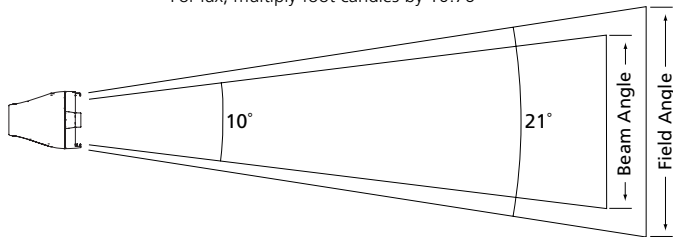

Throw Distance (d)	10'	15'	20'	30'	179.3'
	3.0m	4.6m	6.1m	9.1m	54.7m
Field Diameter	4.0'	6.0'	8.0'	12.0'	-
	1.2m	1.8m	2.4m	3.7m	
Illuminance (fc)	322	143	80	35.7	
Illuminance (lux)	3,462	1,539	866	385	

For field diameter at any distance, multiply distance by .414
For beam diameter at any distance, multiply by 0.189

Cosine Candela Plot

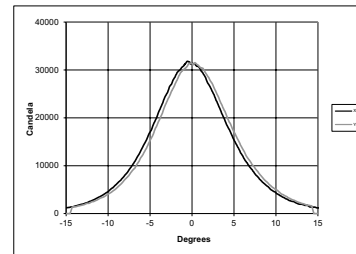

Iso-Illuminance Diagram (Flat Surface Distribution)

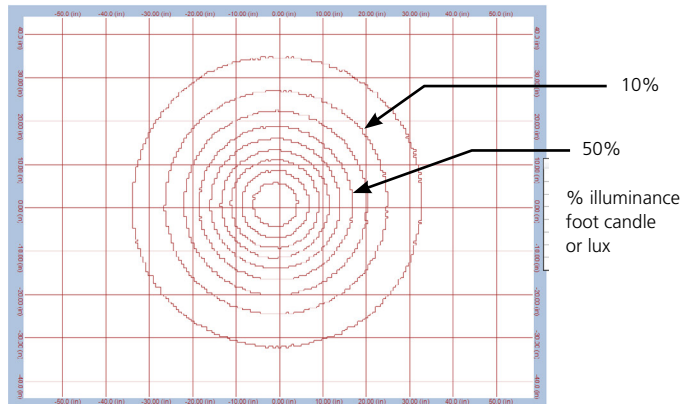

PHYSICAL

Selador D22 Weights and Dimensions

WEIGHT*		SHIPPING WEIGHT	
lbs	kgs	lbs	kgs
6.9	3.13	8.5	3.86

* Does not include mounting hardware

CANOPY

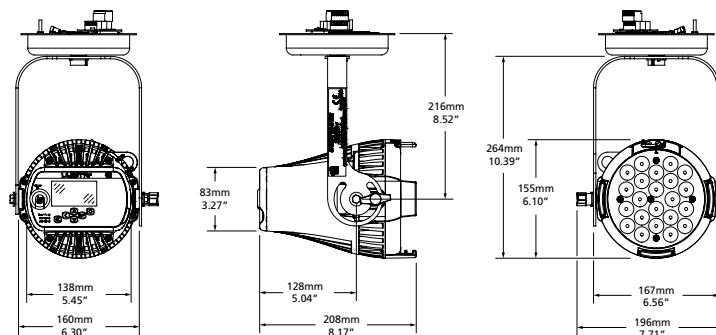

PORTABLE

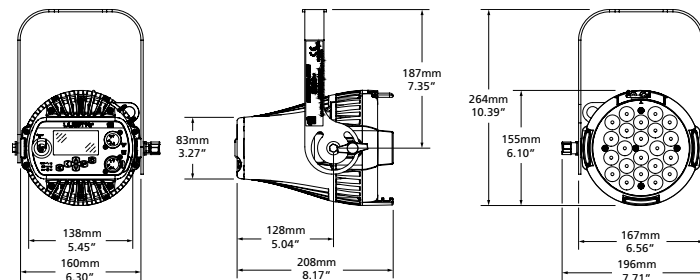

TRACK

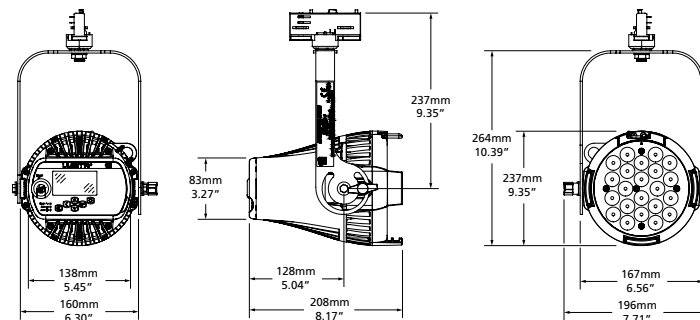

Corporate Headquarters • 3031 Pleasant View Rd, PO Box 620979, Middleton WI 53562 0979 USA • Tel +1 608 831 4116 • Fax +1 608 836 1736

London, UK • Unit 26-28, Victoria Industrial Estate, Victoria Road, London W3 6UU, UK • Tel +44 (0)20 8896 1000 • Fax +44 (0)20 8896 2000

Rome, IT • Via Pieve Torina, 48, 00156 Rome, Italy • Tel +39 (06) 32 111 683 • Fax +44 (0)20 8752 8486

Holzkirchen, DE • Ohmstrasse 3, 83607 Holzkirchen, Germany • Tel +49 (80 24) 47 00-0 • Fax +49 (80 24) 47 00-3 00

Hong Kong • Room 1801, 18/F, Tower 1 Phase 1, Enterprise Square, 9 Sheung Yuet Road, Kowloon Bay, Kowloon, Hong Kong • Tel +852 2799 1220 • Fax +852 2799 9325

Web • www.etconnect.com • Copyright©2014 ETC. All Rights Reserved. All product information and specifications subject to change. 741111002 Rev. B USA 04/14

This product is protected by one or more of the following U.S. Patents: 6,016,038, 6,150,774, 6,788,011, 6,806,659, 6,683,423 and 7,023,543