

MAC 350 Entour™

user manual



Martin®

Dimensions

All dimensions are in millimeters

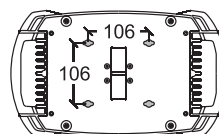
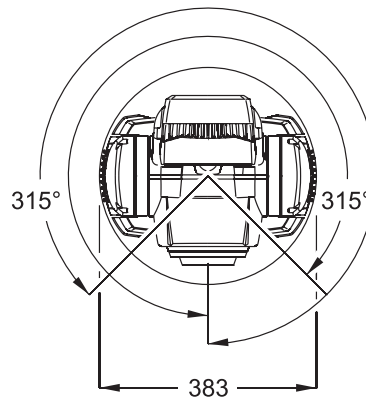
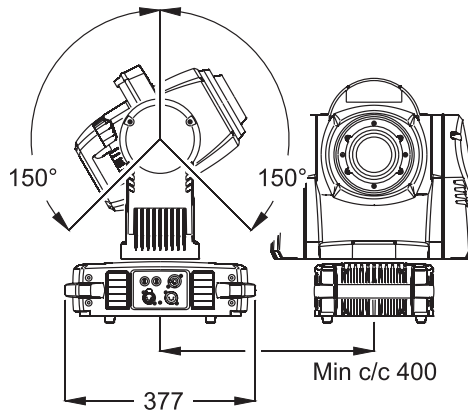
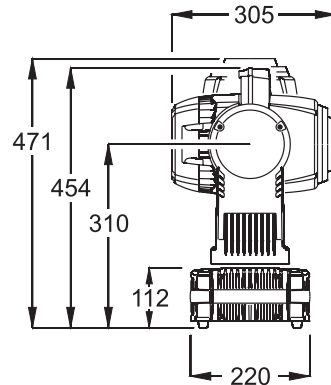

©2010 Martin Professional A/S. Information subject to change without notice. Martin Professional A/S and all affiliated companies disclaim liability for any injury, damage, direct or indirect loss, consequential or economic loss or any other loss occasioned by the use of, inability to use or reliance on the information contained in this manual. The Martin logo, the Martin name and all other trademarks in this document pertaining to services or products by Martin Professional A/S or its affiliates and subsidiaries are trademarks owned or licensed by Martin Professional A/S or its affiliates or subsidiaries. The use of certain patents in Martin™ MAC 350 Entour™ products is licensed by Color Kinetics, Inc. (see details printed on product).

Safety Information



WARNING!

Read the safety precautions in this section before installing, powering, operating or servicing this product.

The following symbols are used to identify important safety information on the product and in this manual:



WARNING!
Safety hazard.
Risk of severe injury or death.



WARNING!
Hazardous voltage. Risk of lethal or severe electric shock.



WARNING!
Fire hazard.



WARNING!
Burn hazard. Hot surface. Do not touch.



WARNING!
LED Light emission. Risk of eye injury.



WARNING!
Refer to user manual.



WARNING! Risk Group 3 LED product according to EN 62471. Do not look into the beam at a distance of less than 8.7 meters (28 ft. 7 ins.) from the front surface of the product. Do not view the light output with optical instruments or any device that may concentrate the beam.



This product is for professional use only. It is not for household use.

This product presents risks of severe injury or death due to fire and burn hazards, electric shock and falls.



Read this manual before installing, powering or servicing the fixture, follow the safety precautions listed below and observe all warnings in this manual and printed on the fixture. If you have questions about how to operate the fixture safely, please contact your Martin supplier or call the Martin 24-hour service hotline on +45 8740 0000, or in the USA on 1-888-tech-180.



PROTECTION FROM ELECTRIC SHOCK

- Disconnect the fixture from AC power before removing or installing any cover or part – including fuses – and when not in use.
- The fixture has double-pole/neutral fusing. If it is not completely disconnected from AC power, parts of the fixture may remain live even if one of the two mains fuses has blown.
- Always ground (earth) the fixture electrically.
- Use only a source of AC power that complies with local building and electrical codes and has both overload and ground-fault (earth-fault) protection.
- Connect the fixture to AC power using a listed, 3-conductor, minimum 1.5 mm² or 16 AWG cable that is rated minimum 10 amp, hard usage. Suitable cable jacket types include SJT, ST, STW, SEO, SEOW and STO.
- Before using the fixture, check that all power distribution equipment and cables are in perfect condition and rated for the current requirements of all connected devices.
- Isolate the fixture from power immediately if any power connector, power cable, seal, cover or other component is damaged, defective, deformed, wet or showing signs of overheating. Do not reapply power until repairs have been completed.
- Do not expose the fixture to rain or moisture. Use in a dry location only.

- Refer any service operation not described in this manual to a qualified technician.



PROTECTION FROM BURNS AND FIRE



- Do not operate the fixture if the ambient temperature (T_a) exceeds 40° C (104° F).
- The exterior of the fixture becomes hot during use. Avoid contact by persons and materials. Allow the fixture to cool for at least 20 minutes before handling.
- Keep all combustible materials (e.g. fabric, wood, paper) at least 200 mm (8 ins.) away from the head.
- Keep flammable materials well away from the fixture.
- Ensure that there is free and unobstructed airflow around the fixture, including the heatsinks in the yoke and base.
- Do not illuminate surfaces within 500 mm (20 ins.) of the fixture.
- Do not attempt to bypass thermostatic switches or fuses. Replace defective fuses with ones of the specified type and rating.
- Do not stick filters, masks or other materials onto any lens or other optical component.
- Do not modify the fixture in any way not described in this manual
- Install only genuine Martin parts.



PROTECTION FROM INJURY



- Do not look at LEDs from a distance of less than 8.7 meters (28 ft. 7 ins.) from the front surface of the fixture without protective eyewear such as shade 4-5 welding goggles. At less than this distance, the LED emission can cause eye injury or irritation. At distances of 8.7 meters (28 ft. 7 ins.) and above, light output is harmless to the naked eye provided that the eye's natural aversion response is not overcome.
- Do not look at LEDs with magnifiers, telescopes, binoculars or similar optical instruments that may concentrate the light output.
- Ensure that persons are not looking at the LEDs from within 8.7 meters (28 ft. 7 ins.) when the product lights up suddenly. This can happen when power is applied, when the product receives a DMX signal, when stand-alone operation starts or when service menu items are selected in the **SERV** menu.
- To minimize the risk of eye irritation or injury, disconnect the fixture from power at all times when the fixture is not in use, and provide well-lit conditions to reduce the pupil diameter of anyone working on or near the fixture.
- Install as described in this manual a secondary attachment such as a safety cable that is approved by an official body such as TÜV as a safety attachment for the weight of the fixture. The safety cable must comply with EN 60598-2-17 Section 17.6.6 and be capable of bearing a static suspended load ten times the weight of the fixture.
- If suspending from a rigging structure, attach the fixture with two evenly spaced clamps. Do not use only one clamp.
- Ensure that any supporting structure and/or hardware used can hold at least 10 times the weight of all the devices they support.
- Allow enough clearance around the head to ensure that it cannot collide with an object or another fixture when it moves.
- Check that all external covers and rigging hardware are securely fastened.
- Block access below the work area and work from a stable platform whenever installing, servicing or moving the fixture.
- Do not operate the fixture with missing or damaged covers, shields or any optical component.

Contents

Dimensions	2
Safety Information.....	3
Introduction	7
Unpacking	7
Using for the first time	8
Connections panel.....	8
AC power	9
Power cable and plugs	9
Mains fuses	10
Applying power	10
Data link	11
Tips for reliable data transmission	11
Connecting the data link	11
Physical installation	12
Mounting the fixture on a truss	12
Setup.....	14
Control panel and menu navigation.....	14
Setting stand-alone, master/slave or DMX operation	14
DMX address and protocol	15
Tailoring performance	15
Readouts	16
Manual control	17
Service utilities.....	17
Calibrating effects	18
LED indicators	18
Effects.....	19
DMX operation	21
Stand-alone operation	22
Programming stand-alone operation	22
Synchronized master/slave operation	23
Service and maintenance.....	25
Gobos	25
Effects access hatch and changing gobos and filters	27
Cleaning.....	28
Lubrication	29
Fuse replacement	29
Firmware installation	29
Circuit board layout	30
MAC 350 Entour DMX protocol	31
Control menu	36
DMX capture menu	39
Control panel shortcuts	39
Adjustment submenu	40
Display messages.....	41
Troubleshooting	42
Specifications	43

Notes

Introduction

Thank you for selecting the MAC 350 Entour™, an intelligent lighting fixture from Martin Professional™. This moving-head spotlight features:

- Seven Luminus CBT-90 (50 W) LEDs
- Minimum LED lifetime: 60 000 hours (to >70% luminous output, manufacturer's figure under manufacturer's test conditions, see "Service and maintenance" on page 25)
- Motorized rotating gobo wheel with 6 interchangeable gobos plus open, indexing, continuous gobo rotation & scrolling, shake
- Motorized color wheel with 8 interchangeable color filters plus open
- Motorized iris
- Electronic shutter with instant intensity control, 2 - 9 Hz strobe effects, pulse effects and shutter fading
- Music-triggered operation available for all effects
- Motorized focus, 2 m (6.5 ft.) to infinity
- 630° of pan and 300° of tilt
- DMX control
- Music trigger
- Onboard control panel and LED display
- Stand-alone operation with up to 100 programmable scenes
- Synchronized (master/slave) stand-alone operation
- 10 pan/tilt and 10 effects macros, freely combinable, selected via DMX or onboard control panel
- Staggered start/macro chase
- DMX effects capture in stand-alone programming
- Fine (16-bit) control of gobo rotation, pan and tilt
- Effects access hatch for fast, tools-free gobo and color filter changes

For the latest firmware updates, documentation, and other information about this and all Martin Professional products, please visit the Martin website at <http://www.martin.com>

Comments or suggestions regarding this user manual may be e-mailed to service@martin.dk or posted to Technical Documentation, Martin Professional A/S, Olof Palmes Allé 18, DK-8200 Aarhus N, Denmark.

This device complies with Part 15 of the FCC Rules. Operation is subject to the following two conditions: (1) This device may not cause harmful interference, and (2) this device must accept any interference received, including interference that may cause undesired operation.

This Class A digital apparatus meets all requirements of the Canadian Interference-Causing Equipment Regulations. *Cet appareil numérique de la classe A respecte toutes les exigences du Règlement sur le Matériel Brouilleur du Canada.*

Unpacking

The MAC 350 Entour is packaged in a cardboard box. The following items are included:

- Two omega clamp attachment brackets with quarter-turn fasteners (P/N 91602001)
- Neutrik PowerCon NAC3FCA AC mains power input connector (P/N05342804)
- This user manual

A 4-unit flightcase is available as an accessory (see "Accessories" on page 45).

Using for the first time



WARNING! Read “Safety Information” on page 3 before installing, powering, operating or servicing the MAC 350 Entour.

Before applying power to the fixture:

- Check the Martin Professional website at www.martin.com for the most recent software, user documentation, technical information and product specifications for the MAC 350 Entour. Martin user manual revisions are identified by the letter at the bottom of page 2.
- Carefully review “Safety Information” on page 3.
- Check that the fixture’s power voltage and frequency range indicated on the serial number label match the local AC power source.
- If drawing power from a socket, install a suitable power plug on the power cable as described in “Power cable and plugs” on page 9.

Connections panel

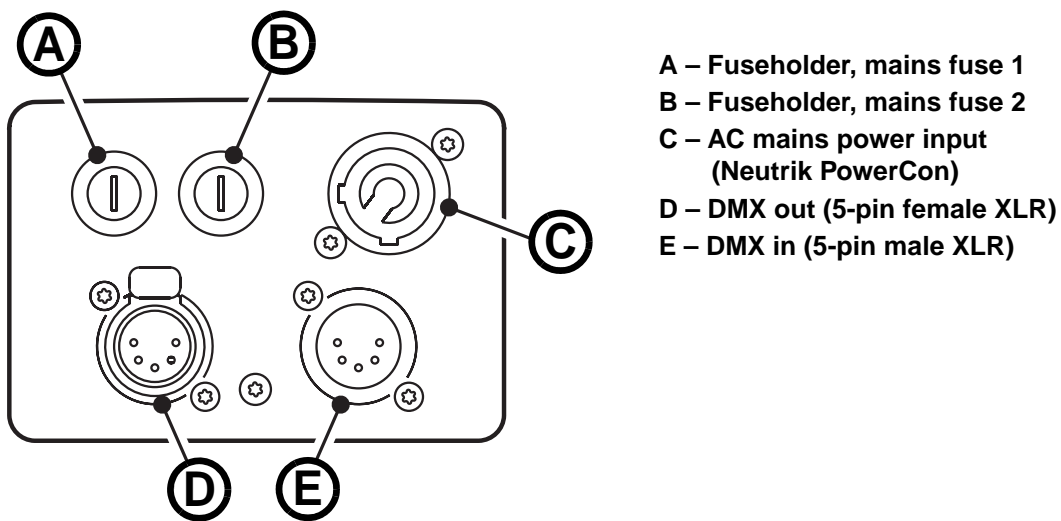

Figure 1: Connections panel overview

AC power



WARNING! Read “Safety Information” starting on page 3 before connecting the MAC 350 Entour to AC power.

For protection from electric shock, the MAC 350 Entour must be grounded (earthed). The power distribution circuit must be equipped with a fuse or circuit breaker and ground-fault (earth-fault) protection.



The MAC 350 Entour does not have a power on/off switch. To shut down power urgently, disconnect the fixture’s power input connector.

Important! Do not use an external dimming system to supply power to the MAC 350 Entour as this may cause damage to the fixture that is not covered by the product warranty.

The MAC 350 Entour can be hard-wired to a building electrical installation if you want to install it permanently. If you do this, provide a means of shutting down power near the fixture. Alternatively a power cable (not supplied) with a power plug suitable for local power output sockets can be used to supply the fixture with AC mains power.

The MAC 350 Entour can be supplied with AC mains power by connecting to one of the following three-wire systems:

- single-phase AC mains power system (live, neutral, ground/earth) at 100-240 V, 50/60 Hz, or
- two phases of a 3-phase delta or split-phase mid-point neutral AC mains power system (phase, phase, ground/earth) to obtain 200-240 V, 50/60 Hz.

Power cable and plugs

The fixture must be connected to AC power using three-conductor cable that is rated 10 A minimum (16 AWG or 1.5 mm²). The cable jacket must be SJT type or better and heat-resistant to 90° C (194° F) minimum. A power cable is not supplied with the product.

The MAC 350 Entour™ is supplied with a male Neutrik PowerCon NAC3FCA locking 3-pole input connector that can be installed on the power cable for power input to the fixture.

If you decide to install a power plug on the fixture’s power cable, install a grounding-type (earthed) plug that is correctly rated for the current and power requirements of the fixture. Follow the plug manufacturer’s instructions. Table 1 shows standard wire color-coding schemes and some possible pin identification schemes; if pins are not clearly identified, or if you have any doubts about proper installation, consult a qualified electrician.







Wire Color (EU)	Wire Color (US)	Conductor	Symbol	Screw (US)
brown	black	live	L	yellow or brass
blue	white	neutral	N	silver
yellow/green	green	ground (earth)	 or 	green

Table 1: Wire color-coding and power connections

When installing a plug on a power cable that will be connected to a single-phase AC mains power system at 100-240 V, 50/60 Hz:

- Connect the ground (earth) conductor to the terminal marked  or .
- Connect the neutral conductor to the terminal marked **N**.
- Connect the live conductor to the terminal marked **L**.

When installing a plug on a power cable that will be connected to two phases of a 3-phase delta or split-phase mid-point neutral system to obtain 200-240 V, 60 Hz AC mains power:

- Connect the ground (earth) conductor to the terminal marked  or .

- Connect one AC power phase to the terminal marked **N** or **Phase 1** or **L1**.
- Connect another AC power phase to the terminal marked **L** or **Phase 2** or **L2**.

Installing the male power input connector on a cable

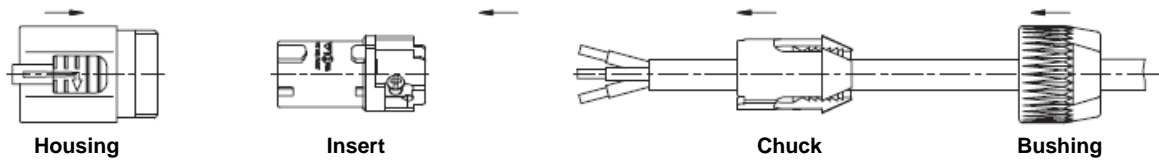

To attach a power cable to the supplied input connector:

1. Slide the bushing over the cable.
2. Slide the white chuck over cables with a diameter (D_a) of 5 - 10 mm (0.2 - 0.4 in.), or the black chuck over cables with a diameter of 10 - 15 mm (0.4 - 0.6 in.).
3. Prepare the end of the cable by stripping 20 mm (0.8 in.) of the cable's outer jacket.
4. Strip 8 mm (1/3 in.) from the end of each of the wires.
5. Insert each of the wire ends into the appropriate terminal (see instructions and Table 1 above) and fasten the clamping device using a small flathead screw driver.
6. Push and insert the chuck into the housing (note that there is a raised key on the chuck to ensure that it is oriented correctly).
7. Fasten the bushing, using a wrench, to a torque of 2.5 Nm (1.8 lb.-ft).

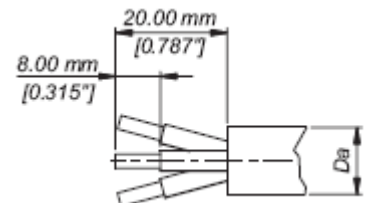

Cable end

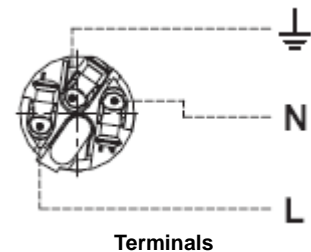

Terminals

Illustrations above used by kind permission of Neutrik AG.

Mains fuses



WARNING! Replace fuses with ones of the same type and rating only.

WARNING! Double-pole/neutral fusing.



The MAC 350 Entour is protected by two 10 amp slow-blow mains fuses located in fuseholders next to the power input connector. See "Fuse replacement" on page 29 for details of accessing and changing the fuse.

Applying power



WARNING! Do not apply AC mains power to the fixture at any other voltage than that specified on the fixture's serial number label.

MAC 350 Entour™ fixtures are factory-configured to accept AC mains power at 100-240 V nominal, 50/60 Hz.

Check that power cables are undamaged and rated for the current requirements of all connected devices.

Plug the fixture's power cable into the fixture's Neutrik PowerCon socket and a grounded (earthed) source of AC power.

Important! Do not supply the fixture with power from a dimmer system, as this may cause damage that is not covered by the product guarantee.

Data link

A data link is required in order to control a MAC 350 Entour via DMX or synchronize fixtures in stand-alone operation.

The MAC 350 Entour has 5-pin XLR connectors for DMX data input and output. The pin-out on all connectors is pin 1 = shield, pin 2 = cold (-), and pin 3 = hot (+).

Pins 4 and 5 in the 5-pin XLR connectors are available for enhanced features in conformity with DMX 512-A. Pin-out is pin 4 = data 2 cold (-) and pin 5 = data 2 hot (+).

Tips for reliable data transmission

- Use shielded twisted-pair cable designed for RS-485 devices: standard microphone cable cannot transmit control data reliably over long runs. 24 AWG cable is suitable for runs up to 300 meters (1000 ft). Heavier gauge cable and/or an amplifier is recommended for longer runs.
- To split the link into branches, use a splitter such as the Martin 4-Channel Opto-Isolated RS-485 Splitter/Amplifier.
- Do not overload the link. Up to 32 devices may be connected on a serial link.
- Terminate the link by installing a termination plug in the output socket of the last fixture. The termination plug, which is a male XLR plug with a 120 Ohm, 0.25 Watt resistor soldered between pins 2 and 3, “soaks up” the control signal so it does not reflect and cause interference. If a splitter is used, terminate each branch of the link.
- Some older fixtures have reversed polarity data sockets (pin 2 hot and pin 3 cold). Polarity is normally labelled on devices and described in user manuals. *Use a phase-reversing cable between the MAC 350 Entour and any device with reversed polarity.*

Connecting the data link

1. Connect the DMX data output from the controller to the first MAC 350 Entour's DMX input socket.
2. Connect the output of the first fixture to the input of the next fixture.
3. Insert a male 120 Ohm XLR termination plug in the DMX output of the last fixture on the link.

Physical installation

The MAC 350 Entour can be placed on a horizontal surface such as a stage or clamped to a truss in any orientation. The quarter-turn clamp bracket mounting points in the base of the fixture allow clamp brackets to be fastened parallel or perpendicular to the front of the fixture.



WARNING! Attach an approved safety cable to the attachment point labelled “SAFETY WIRE” in the base of the fixture. Do not use the carrying handles for secondary attachment.



Check that all surfaces to be illuminated are minimum 500 mm (20 ins.) from the fixture, that combustible materials (wood, fabric, paper, etc.) are minimum 200 mm (8 ins.) from the head, that there is free airflow around the fixture (including the heatsinks in the yoke and base) and that there are no flammable materials nearby.



Make sure that, wherever the product is installed, people are not able to look directly down the LED beam from within a distance of 8.7 meters (28 ft. 7 ins.). At less than this distance, the LED emission can cause eye injury or irritation. At distances of 8.7 meters (28 ft. 7 ins.) and above, light output is harmless to the naked eye provided that the eye's natural aversion response is not overcome.

Make sure that it is impossible for the moving head to collide with another fixture or other object.

Mounting the fixture on a truss

The MAC 350 Entour can be clamped to a truss or similar rigging structure in any orientation. Clamp brackets can be attached to the base of the fixture using quarter-turn quick connectors.



WARNING! Use two clamps to rig the fixture. Lock each clamp by turning both 1/4-turn fasteners fully clockwise.

To clamp a MAC 350 Entour to a truss:

1. Check that the rigging structure can bear at least 10 times the weight of all fixtures and equipment to be installed on it.
2. Obtain two rigging clamps and check that they are undamaged and can bear at least 10 times the weight of the fixture. Bolt each clamp securely to a clamp bracket with a minimum grade 8.8 M12 bolt and lock nut.
3. See Figure 2. Align each of the two clamp brackets with two mounting points in the base. Insert the quarter-turn fasteners into the base and turn all levers a full 90° clockwise to lock.
4. Block access under the work area. Working from a stable platform, hang the fixture on the truss with the arrow on the base towards the area to be illuminated. Tighten the rigging clamps.

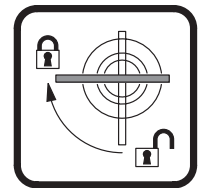
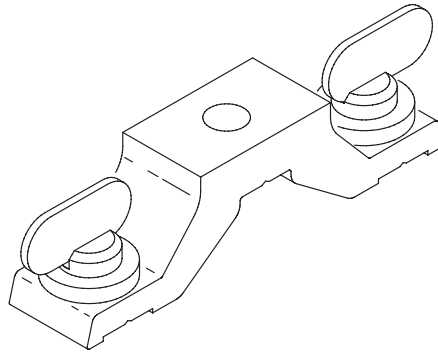

Figure 2: Clamp bracket and quarter-turn fasteners

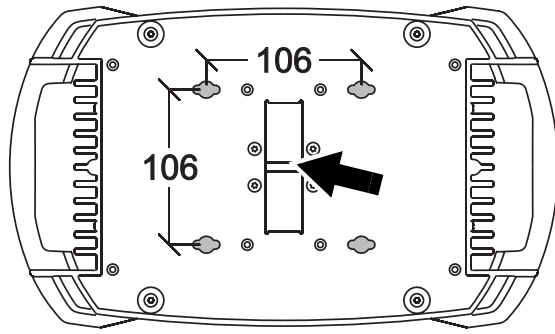

Figure 3: Safety cable attachment point

5. See Figure 3. Secure the fixture against clamp or bracket failure with a safety wire that can bear at least 10 times the weight of the fixture using the attachment point marked "SAFETY WIRE" in the base of the fixture. This attachment point is designed to fit a carabiner clamp. Do not use carrying handles as safety attachment points.

6. Check that the head will not collide with other fixtures or objects. Allow a minimum center-to-center distance of 400 mm (15.8 ins.) minimum between MAC 350 Entour fixtures.

Setup



WARNING! Read “Safety Information” on page 3 before installing, powering, operating or servicing the MAC 350 Entour.

Control panel and menu navigation

The DMX address and any status messages are shown in the display when the MAC 350 Entour is powered on.

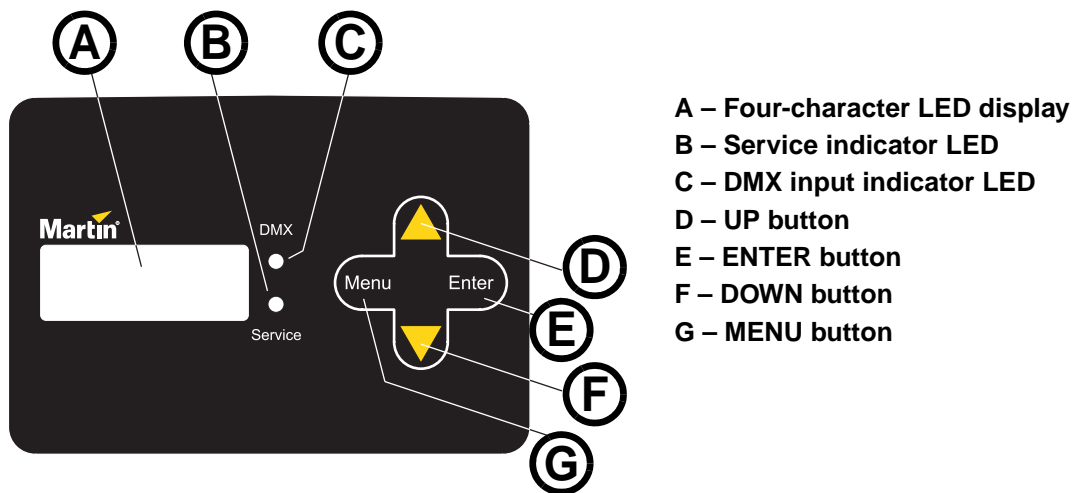

Figure 4: Control panel and display

The control panel is used to set the MAC 350 Entour to DMX or stand-alone (single fixture or synchronized master/slave) operation, set its DMX address, configure individual fixture settings (personality), read out data, and execute service utilities.

See “Control menu” starting on page 37 for a complete list of the menus and commands available in the control panel.

See Figure 4. To enter a menu, press [Menu]. Press the [Up] and [Down] arrows to scroll within a menu. To select a function or submenu, press [Enter]. To escape a function or move back one level in the menu structure, press [Menu].

Note: [Enter] must be pressed and held for a few seconds to enter the Service menu (**SERV**).

Setting stand-alone, master/slave or DMX operation

DMX control, stand-alone and synchronized master/slave modes are selected as follows:

- To set the MAC 350 Entour to stand-alone operation, press [Up] or [Down] until **SA** is displayed, then select **RUN**, then **ENA**.
- To set the MAC 350 Entour to synchronized stand-alone operation, in which a master fixture sends synchronizing signals to slave fixtures, select **SA**→**SAE** then **MAS** for the master fixture, **SLA** for slave fixtures, or **SIN** to return to single fixture operation.
- To disable stand-alone operation and return the MAC 350 Entour to DMX control, select **SA**→**RUN**→**DIS**.

The MAC 350 Entour is supplied configured for DMX control by default.

DMX address and protocol

The DMX address, also known as the start channel, is the first channel used to receive instructions from the controller. For independent control, each fixture must be assigned its own control channels. Two MAC 350 Entours may share the same address, however, if identical behavior is desired. Address sharing can be useful for diagnostic purposes and symmetric control, particularly when combined with the inverse pan and tilt options.

Depending on the selected DMX mode, the MAC 350 Entour requires 14 or 17 DMX channels. 8-bit mode uses 14 channels and provides coarse control of all effects. 16-bit mode uses 17 channels and provides the 8-bit mode features plus fine control of gobo rotation, pan and tilt.

DMX addressing is limited automatically, making it impossible to set the DMX address so high that you are left without enough control channels for the fixture.

To set DMX address and 8-bit or 16-bit mode

1. Press [Menu] to enter the main menu.
2. Press [Up] or [Down] until **ADDR** is displayed. Press [Enter]. To snap to channel 1, press [Enter] and [Up]. Scroll to the desired channel and press [Enter]. Press [Menu] to return to the first level of the main menu.
3. Press [Up] or [Down] until **PSET** is displayed. Press [Enter]. Select **8BT** for 8-bit mode or **16BT** for 16-bit mode. Press [Enter]. 16-bit mode uses 3 additional DMX channels to provide fine control of rotating gobo, pan and tilt.

Tailoring performance

Movement

The MAC 350 Entour provides several options in the pan/tilt settings menu **PERS**→**PTST** for optimizing movement for different applications.

- The pan/tilt speed (**PTSP**) menu provides 3 settings: **FAST**, **NORM** and **SLOW**. The **FAST** setting provides better performance in applications where speed is most important. This is the default setting. The **SLOW** setting gives smoother but slower movement. **NORM** is an intermediate setting.
- The pan and tilt invert (**SWAP**) menu swaps pan and tilt so that commands sent on the pan channel are applied to tilt and commands sent on the tilt channel are applied to pan.
- **PINV** and **TINV** invert pan and tilt movement so that for example a pan left command makes the fixture pan right instead.
- The effects speed (**EFSP**) menu provides 4 settings: **FAST**, **NORM**, **SLOW** and **PTSS** (pan/tilt speed slave). If set to **PTSS**, effects speed follows the pan/tilt speed set in the **PTSP** menu. This is the default setting.
- The shortcuts (**PERS**→**SCUT**) setting determines whether effects take the shortest path between two positions, crossing the open position if necessary, or always avoid the open position.

Display

The display on/off setting (**PERS**→**DISP**) determines whether the display remains on constantly (**ON**) or goes into sleep mode 2 minutes after the last key press (**2 MN**) or 10 minutes after the last key press (**10MN**). The display can also be set so that it is activated if the fixture diagnoses an error.

The display intensity (**PERS**→**DINT**) setting controls display brightness. Select **AUTO** for automatic display or manually set the intensity to a level from **10** to **100**.

To invert the display when the fixture is installed base up, press [Up] and [Down] simultaneously.

DMX reset

The DMX reset (**PERS**→**DRES**) setting controls the behavior of the reset command. When set to **ON**, the command is fully enabled. When set to **OFF**, the command is disabled to prevent accidental resets. When set to **5SEC**, the command must be sent for five seconds. The special combination of DMX values listed under channel 1 on page 32 allows you to execute a reset even when the command is disabled.

Cooling fans

The cooling fans menu (**PERS**→**FANS**) gives three options:

- When set to **REG** (the default setting), fans are thermostatically regulated. Fan speed is a function of the amount of heat the fixture produces. If light output is reduced at the lighting desk, fans will run more slowly, giving reduced noise.
- When set to **FULL**, fans run permanently at full speed.
- When set to **SLNT** (silent), light output is limited so that convection cooling is enough to cool the fixture. To minimize noise, fans are either totally still or operate very slowly.

Dimming curve

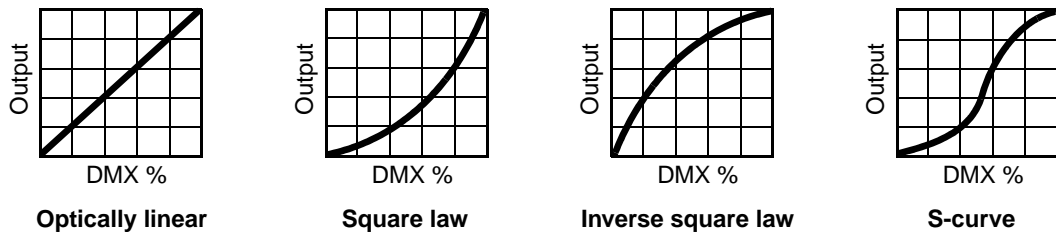

Figure 5: Dimming curve options

The dimming curve (**DIM**) menu provides four dimming options (see Figure 5):

- **LIN** (linear) – the increase in light intensity appears to be linear as DMX value is increased.
- **SQR** (square law) – light intensity control is finer at low levels and coarser at high levels.
- **ISQR** (inverse square law) – light intensity control is coarser at low levels and finer at high levels.
- **SCUR** (S-curve) – light intensity control is finer at low levels and high levels and coarser at medium levels.

Custom settings

The custom settings function **DFSE**→**CUS1 - CUS3** allows you to save and recall three sets of fixture settings. The savable settings are DMX mode, pan/tilt speed, pan/tilt inverse and swap, display, DMX reset, shortcuts, noise reduction mode and effects speed.

All settings can be returned to factory defaults using the **DFSE**→**FACT**→**LOAD** command.

Readouts

Software version

INFO→**VERS** displays the currently installed fixture software (firmware) version. The firmware version is also displayed briefly at startup.

Cooling fan speed

INFO→**FANS** displays the current head and LED PCB cooling fan speed in rpm.

Hours of use

INFO→**TIME**→**POHR** provides a resettable (**RSET**) and a non-resettable (**TOTL**) counter for hours of use (i.e. number of hours with power applied to the fixture). To return the resettable counter to zero, display it and then press [Up] until the counter reads **0**. The non-resettable counter displays total hours of use since the fixture was manufactured.

Temperature

INFO→**MTMP**, **INFO**→**HTMP** and **INFO**→**LTMP** provide temperature readouts for the main PCB in the base, for the head module and for the LED PCB respectively. In each case, **CURR** displays the current temperature. **MSR** displays the maximum temperature since the log was reset, and **MR** displays the maximum temperature recorded since manufacture. **MR** is non-resettable.

LED power

INFO→**LPWR** provides LED power readouts. **CURR** displays the current LED power. **MSR** displays the maximum LED power level since the log was reset, and **MR** displays the maximum power level recorded since manufacture. **MR** is non-resettable.

RDM Unique ID and manufacturer's serial number

INFO→**SNUM** displays the fixture's unique RDM ID number and the fixture's serial number, both of which are set at the factory and are non-resettable.

Manual control

The manual control menu (**MAN**) allows you to reset the fixture (**RST**) and control individual effects. See 'Control Menu' on page 39 for a full list of commands.

Manual control

The manual control menu **MAN** lets you control the fixture without a DMX controller. As well as letting you reset the fixture and control individual effects, the manual control menu allows any combination of the 40 effect macros and 40 pan/tilt macros to be selected (**MAN**→**EFMA** and **MAN**→**PTMA**). Selecting a macro starts a pre-programmed sequence of effects, effectively allowing you to run a stand-alone light show without the need for a DMX controller.

Service utilities

Important! *[Enter] must be held for several seconds to access the service menu SERV.*

Test sequences

The **TEST** menu lets you test the fixture's effects and pan/tilt without a controller. Note that **TEST**→**PCBT** provides routines for circuit board testing that are for service use by Martin only.

DMX

The DMX log (**DMXL**) menu provides useful information for troubleshooting control problems.

RATE displays the DMX refresh rate in packets per second. Values lower than 10 or higher than 44 may result in erratic performance, especially when using tracking mode.

QUAL displays the quality of the received DMX data as a percentage of packets received. Values much below 100 indicate interference, poor connections, or other problems with the serial data link that are the most common cause of control problems.

STCO displays the DMX start code. Packets with a start code other than 0 may cause irregular performance.

The remaining options under **DMXL** display the DMX values received on each channel. If the fixture does not behave as expected, reading the DMX values can help you troubleshoot the problem.

Feedback toggles

On-the-fly position correction systems monitor pan and tilt. If a position error is detected, the fixture self-corrects. If the system cannot correct the position within 10 seconds, feedback is automatically disabled.

Pan/tilt position correction can be temporarily disabled by setting **SERV**→**FEBA** to off. The Off setting is not saved, and position correction systems will be re-enabled the next time the fixture starts.

Adjustment

The adjustment menu (**SERV**→**ADJ**) provides manual control for making mechanical adjustments. See page 40.

Calibration

The calibration menu (**SERV**→**CAL**) allows offsets relative to mechanical reset or home positions to be entered in the fixture software. This lets you fine tune optical alignment and achieve uniform performance between fixtures. Shutter fading and focus are calibrated to defined points. The other effects are calibrated relative to an arbitrary reference fixture. See “Calibrating effects” on page 28.

All offsets can be set to the middle of their adjustment range by applying the default offset command: select **SERV**→**CAL**→**DFOF**→**SURE** then press [Enter].

Software upload

The upload mode command (**SERV**→**UPLD**) prepares the fixture for a software upload. This command is not normally necessary, as upload mode is engaged automatically by the uploader. See “Firmware installation” on page 30.

LED indicators

See Figure 4 on page 14. The two LEDs on the right of the display give the following information:

DMX LED

The DMX LED lights when the fixture is receiving a valid DMX signal.

Service LED

The Service LED lights red if the fixture requires a service intervention or if the service timer alert has reached the number of hours set for it. At the same time, a message will appear in the display indicating the type of service required.

The Service LED blinks when the fixture is in factory service mode.

Effects

This section describes the effects available in the MAC 350 Entour. Details of controlling effects via DMX or programming effects in stand-alone operation are covered in the relevant sections later in this manual.

Electronic shutter effect

The electronic shutter effect provides instant open and blackout as well as variable speed regular and random strobe, opening/closing pulse effects, music triggered operation and fading.

Electronic dimming

The LEDs can be dimmed smoothly from 100% to zero. Note that 4 different dimming curves are available in the **PERS→DIM** menu.

Color wheel

Besides an open position with no color, the color wheel provides 8 dichroic color filters in the following positions:

- | | |
|--------------------------------|----------------------------|
| 1. Blue – P/N 46404433 | 5. Pink – P/N 46404431 |
| 2. Light green – P/N 46404434 | 6. Magenta – P/N 46404439 |
| 3. Orange – P/N 46404436 | 7. Congo – P/N 46404432 |
| 4. Light yellow – P/N 46404435 | 8. Deep red – P/N 46404438 |

The color wheel can be scrolled continuously (giving split colors), scrolled in steps (giving full colors only) rotated continuously, set to music-triggered operation or set to random color chases (auto trig).

Rotating gobo wheel

The gobo wheel provides 6 rotating gobos. The gobos supplied as standard are shown in Figure 6.

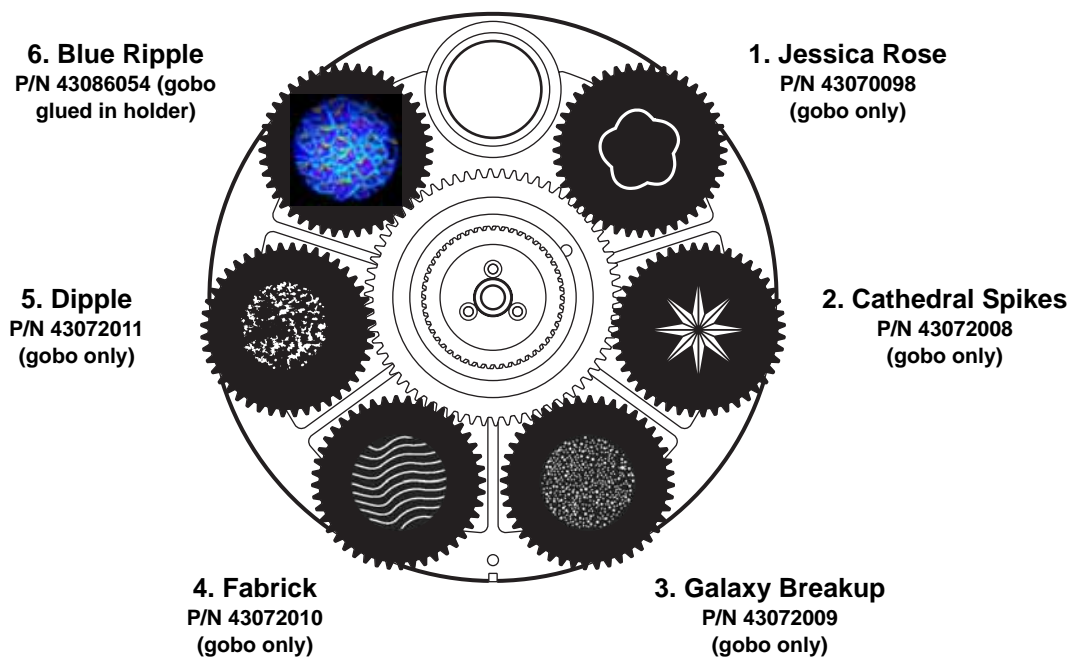

Figure 6: Gobo wheel as seen from front lens

Any of the six rotating gobos can be selected at an indexed angle, rotated, or shaken from side to side at an indexed angle or while rotating. The entire gobo wheel can also be scrolled continuously, and gobos set to music triggered gobo chase.

Iris

The motorized iris can be opened or closed smoothly, with pulse effects also available.

Focus

The motorized focus system can be varied from infinity to approximately 2 meters (6.4 feet).

Macros

Macros are pre-programmed sequences stored in the fixture's memory that can reduce the need for programming. The MAC 350 Entour has 10 pan/tilt and 10 effects macros available. Pan/tilt and effects macros are selected separately and can therefore be run in any combination.

Pan/tilt macros

1. Circle large CW
2. Pan wave large CW
3. Tilt wave large CW
4. Circle small CCW
5. Pan wave small CCW
6. Tilt wave small CCW
7. Large move slow CW
8. Large move slow CCW
9. Large move fast CW
10. Large move fast CCW

Effects macros

1. Shutter chase
2. Single color bump
3. Two color bump
4. Single gobo bump
5. Index/rotate FX
6. Focus sine wave
7. Camera flash
8. Shutter fade
9. Gobo wheels scroll bounce
10. Color scroll

Table 2. List of macros

Macro chase/staggered start feature

Each macro can be started:

- at the beginning of its sequence by selecting **1.1**, **2.1**, **3.1**, etc.
- 25% of the way through its sequence by selecting **1.2**, **2.2**, **3.2**, etc.
- 50% of the way through its sequence by selecting **1.3**, **2.3**, **3.3**, etc.
- 75% of the way through its sequence by selecting **1.4**, **2.4**, **3.4**, etc.

This feature makes it possible to run the same macro in multiple fixtures with staggered starting points (i.e. fixtures reach the start of the macro one after the other), so that the macro appears to run in a chase.

For example, if you have four MAC 350 Entour fixtures side by side and you set the first fixture to run macro **1.1**, the next fixture to run macro **1.2**, the next to run macro **1.3** and the last to run macro **1.4**, and you start all fixtures running their macro at the same time, the fixtures will run macro **1** in a chase.

Note that a regular macro chase requires that all fixtures start their macro at exactly the same time so that they reach the start of the macro at regular intervals. Macro chases are therefore primarily intended for use with DMX control, but they can be programmed in synchronized stand-alone operation.

Pan and tilt

The MAC 350 Entour's moving head can be panned through 630° and tilted through 300°.

Music trig sensitivity

The MAC 350 Entour's music trig sensor uses automatic gain control to match the fixture's sensitivity to the music beat. Adjustment is not necessary.

DMX operation



WARNING! Read “Safety Information” on page 3 before installing, powering, operating or servicing the MAC 350 Entour.

This section describes only DMX control features that require particular explanation. See “MAC 350 Entour DMX protocol” on page 32 for full list of the DMX channels and values required to control the different effects. See “Effects” on page 19 for a full description of the fixture’s effects.

8- and 16-bit control

The MAC 350 Entour has two DMX operating modes, 8-bit and 16-bit. 16-bit mode uses three more DMX channels than 8-bit mode and provides all the features of 8-bit mode plus fine control of rotating gobo, pan and tilt. You can select the DMX operating mode in the **PSET** menu.

Where fine control is available, the main control channel sets the first 8 bits (the most significant byte or MSB), and the fine channels set the second 8 bits (the least significant byte or LSB) of the 16-bit control byte. In other words, the fine channel works within the position set by the coarse channel.

Fixture reset

If an effect loses its indexing and fails to move to programmed positions, the fixture can be reset from the controller by sending the “Reset” command on DMX channel 1.

If DMX reset is disabled in the control menu (**PERS**→**DRES**→**OFF**), the reset command can only be executed if color 8 is selected (DMX value 128 or 145 - 148 on channel 3) and gobo 6 is selected (DMX value 24 - 27 or 52 - 55 on channel 4).

If **PERS**→**DRES** is set to **5SEC**, the reset command must be sent for 5 seconds before it is executed.

Pan/tilt speed and effects speed channels

The pan/tilt and effects speed channels 11 and 12 in 8-bit mode or 14 and 15 in 16-bit mode provide two methods of controlling the speed of pan/tilt and effect movement: “tracking” and “vector”.

Tracking versus vector control

Important! *Movement may be rough and unpredictable if controller fade times are combined with vector speed values.*

if you select *tracking mode*, speed is determined by the cross-fade time programmed on the controller. With this method, the controller divides a movement into tiny steps that the fixture “tracks”, or follows.

If you select *vector mode*, the fixture determines speed according to the DMX value you send on the speed channel. Vector mode therefore allows you to control the speed of scene changes on controllers without cross-faders. It can also give smoother movement, particularly at slow speeds, when using a controller that sends slow or irregular tracking updates.

If the DMX controller has variable cross-fade times, set them to zero when using vector mode.

Personality overrides

Using the pan/tilt speed channel, you can set pan and tilt to tracking mode and at the same time set the fixture’s own pan/tilt speed setting to normal or fast from the DMX controller, overriding the pan/tilt speed setting available in the fixture’s control menus.

Using the effects speed channel, you can set the effects to tracking and at the same time set shortcuts to on or off from the DMX controller, overriding the shortcuts setting available in the fixture’s control menus.

Stand-alone operation



WARNING! Read “Safety Information” on page 3 before installing, powering, operating or servicing the MAC 350 Entour.

This section describes how to program and run stand-alone light shows on the MAC 350 Entour without a DMX controller. See the **SA** menu under “Control menu” on page 37 for a table listing stand-alone commands. See “Effects” on page 19 for a full description of the MAC 350 Entour’s effects.

In stand-alone operation, the MAC 350 Entour can play up to 100 pre-programmed scenes continuously in a loop. A MAC 350 Entour can either run a stand-alone show independently, or scene changes can be synchronized with other MAC 350 Entour fixtures.

About scenes

A stand-alone light show consists of a sequence of scenes. Each scene is a particular lighting effect with predetermined effects (color, gobo, etc.) and duration.

See Figure 7. Each scene has a dynamic part – the fade – during which effects move to the scene’s programmed positions, and a static part – the wait – where effects do not change.

The duration of the fade and duration of the wait must be programmed individually for each scene. The total time it takes a scene to execute is the sum of the fade and wait times.

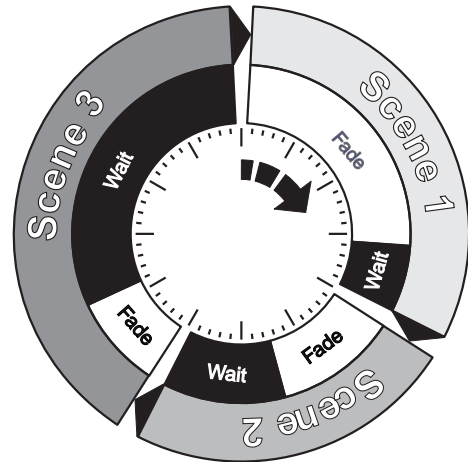

Figure 7: Scene timing

Programming stand-alone operation

To program a scene in the current stand-alone sequence:

1. In the control panel, select **SA** → **PROG**
2. Configure the effects in the scene in the following menus:
 - **SHUT** (shutter)
 - **INT** (intensity)
 - **COL** (color)
 - **GOBO** (gobo selection)
 - **RGBO** (gobo rotation)
 - **IRIS** (iris)
 - **FOCU** (focus)
 - **PTMA** (pan/tilt macros)
 - **EFMA** (effects macros)
 - **PAN** and **TILT** (pan and tilt positions).
3. Select a fade time using **FADE** and a wait time using **WAIT**.
4. Store the scene in your stand-alone sequence as follows:
 - Use the **ADD** command to save the current scene as a new scene at the end of the stand-alone sequence.
 - Use the **INS** command to save the current scene as a new scene at the start of the stand-alone sequence.
 - Use the **STOR** command to save changes to the current scene. Note that the **STOR** command does not create a new scene. It only saves changes to a scene that has already been created using the **ADD** or **INS** commands.

You can manage the scenes you have created using the **NEXT**, **PREV**, **DEL** and **CLR** commands.

You can preview the stand-alone sequence using the **VIEW** command.

Programming effects in a stand-alone scene using a DMX controller

Instead of programming effects in stand-alone scenes manually via the control panel, it is possible to apply effects to the MAC 350 Entour using a DMX controller, then use the **GDMX** menu in the control panel to capture all the applied effects and save them in a scene in the MAC 350 Entour's stand-alone show.

To capture effects applied from a DMX controller:

1. Connect a DMX controller to the MAC 350 Entour and apply the desired effects.
2. Go to **SA** → **PROG** → **GDMX** → **DMX** → **STOR** in the MAC 350 Entour control menu.
3. Select **ADD** to add a scene with the applied effects to the end of the stand-alone sequence or **INS** to insert a scene with the applied effects immediately before the current scene.

As with scenes that you have programmed manually, you can use the **NEXT**, **PREV**, **DEL** and **CLR** commands to manage the scenes you have created.

Note that a stand-alone scene programmed using the DMX capture method may be slightly different to the original DMX scene. This is because effects in stand-alone scenes are slightly simplified compared to DMX. For example, gobo rotation speed can be varied with a resolution of nearly 120 values in each direction via DMX, but only slow, medium and fast speeds are available in stand-alone mode. When the MAC 350 Entour captures DMX effects, it finds the closest equivalent stand-alone effects and stores these.

Synchronized master/slave operation

If you are running multiple fixtures in stand-alone mode and the fixtures are connected on a data link, you can synchronize action so that all fixtures start their programmed shows and start fading to the next scene at the same time.

An MAC 350 Entour running a stand-alone show can perform synchronized scene changes with other MAC 350 Entour fixtures as well as Martin fixtures of the following types:

- Exterior 1200 Wash™
- Exterior 1200 Image Projector™
- Exterior 200™
- Exterior 600™
- Exterior 600 Compact™
- Inground 200 CMY™
- Inground 200 6-Color™
- FiberSource CMY150™
- Imager™
- Alien O2™
- MiniMAC Maestro™
- Easypix™
- smartMAC™

In synchronized operation, one fixture is set as the master and the others are set as slaves. Each fixture must be programmed with its own show. When the master fades to the next scene or starts its show from the beginning again, it tells each slave fixture to fade to its next scene or start its show again. In other words, each slave fixture will run its show repeatedly in a cycle, changing scene when prompted to by the master, until the master finishes its own show and signals that all fixtures should start from the first scene once again.

If you want to keep things as simple as possible when programming synchronized operation, ensure that:

1. Every fixture has the same number of scenes.
2. Scene times are a few seconds longer on the master fixture than on slave fixtures (this will ensure that slave fixtures always have time to finish scenes before the master tells them to start the next scene).

It is important to note that the only commands transmitted by the master are scene change and show start commands. No data about the *appearance* of the scene is transmitted between fixtures.

For a more detailed explanation of synchronized operation and how advanced effects can be created by programming fixtures with a different number of scenes, see the next section.

Synchronized stand-alone operation: advanced features

Note: *This section gives advanced information about stand-alone synchronized operation. You do not need to read it unless you need help troubleshooting unexpected stand-alone behavior or you want to program advanced synchronized light shows.*

The principles in stand-alone synchronized operation are as follows:

1. A scene contains a fade section, followed by a wait section.
2. Each fixture can be individually programmed with up to 100 scenes, and each scene can have its own individual fade and wait times.
3. Scenes are numbered from 0 to 99.

4. In synchronized operation, one master fixture issues commands to the other slave fixtures to “go to scene xx”, where xx is the scene number that the master will execute next.
5. If a slave has fewer scenes than the master, it will derive which scene to go to by dividing the number of the scene it has been commanded to go to (scene 5, for example) by the total number of scenes that the slave fixture has (4, for example) in whole numbers (no decimal places). In this example 5 divided by 4 results in 1, with 1 remainder. This remainder will be the number of the scene that the slave fixture starts - scene 1. Generally though, when a Slave fixture reaches its own last scene before the Master fixture, a “go to scene xx” message will result in the first scene being played.
6. If a slave has more scenes than the master calls, the last scenes in the slave will never be executed, as is the case with scene S4 in the following example.

F=fade, W=wait Timeline =>

	M0	M1	M2	M3	
Programmed in Master	F W	F W	F W	F W	
	S0	S1	S2	S3	S4
Programmed in Slave	F W	F W	F W	F W	F W
Result	M0	M1	M2	M3	
	F W	F W	F W	F W	
	S0	S1	S2	S3	
	F W	F W	F W	-- --	F W

7. In synchronized operation, the wait time is determined by the master. Every slave fixture fades and waits at its own rate and then remains in the “wait” state until it receives a “start scene xx” command from the master.
8. A slave fixture will not listen for the next message from the master fixture before it has finished its current scene. This may result in a slave skipping a scene if the slave has a longer scene time than the master. Note that in the following example, the scenes in the slave run out of their programmed sequence because scenes 0 and 2 on the slave are longer than the corresponding scenes on the master.

M=master, S=slave
F=fade, W=wait Time >

Programmed	M0	M1	M2		
Master	F W	F W	F W		
	S0	S1	S2		
Slave	F W	F W	F W		
Result	M0	M1	M2	M0	M1
Master	F W	F W	F W	F W	F W
	S0		S2		S1
Slave	F W		F W	-- --	F W

Service and maintenance



WARNING! Read “Safety Information” on page 3 before servicing the MAC 350 Entour. Disconnect the fixture from AC mains power and allow to cool for at least 20 minutes before handling. Wear heat-resistant gloves before opening the effects access hatch. Do not view the light output from less than 8.7 meters (28 ft. 7 ins.) without shade 4-5 welding goggles. Work in well-lit conditions. Be prepared for the fixture to light suddenly if connected to power.



Important! Refer any service operation not described here to a qualified service technician. It is possible to replace individual LEDs on the LED board, but this operation can cause serious damage that is not covered by the product warranty and may be carried out only by Martin Service or its authorized agents.

Important! Excessive dust, smoke fluid, and particle buildup degrades performance, causes overheating and will damage the fixture. Damage caused by inadequate cleaning or maintenance is not covered by the product warranty.

Important! As with electronic components in general, the MAC 350 Entour’s PCBs are sensitive to ESD (electrostatic discharge). Take precautions to avoid ESD damage before opening the fixture. Service electronic components at a static-safe workstation only.

To maximize the life of the MAC 350 Entour and protect the investment it represents, the user will need to clean the fixture periodically, and it is also possible for the user to change color filters, rotating gobos, mains fuses and update the firmware. All other service operations on the MAC 350 Entour™ must be carried out by Martin Professional or its approved service agents.

Installation, on-site service and maintenance can be provided worldwide by the Martin Professional Global Service organization and its approved agents, giving owners access to Martin’s expertise and product knowledge in a partnership that will ensure the highest level of performance throughout the product’s lifetime. Please contact your Martin supplier for details.

It is Martin policy to use the best-quality materials and coatings available to ensure optimum performance and the longest possible component lifetimes. However, optical components in all lighting fixtures are subject to wear and tear over the life of the fixture, resulting in gradual changes in color rendition of dichroic filters or the specular properties of reflectors, for example. The extent of wear and tear depends heavily on operating conditions, maintenance and environment, so it is impossible to specify precise lifetimes for optical components. However, you will eventually need to replace optical components if their characteristics are affected by wear and tear after an extended period of use and if you require fixtures to perform within very precise optical and color parameters.

The manufacturer’s LED lifetime data is based on performance under the manufacturer’s test conditions. As with all LEDs, the gradual reduction in luminous output will be accelerated when LEDs are used in a fixture, where conditions are much tougher than in manufacturer’s testing. To maximize LED lifetimes, keep the ambient temperature as low as possible and drive the LEDs no harder and for no longer than necessary.

Service timer

The service interval timer **AIRF** in the **INFO** menu runs whenever the fixture is powered on. The timer can be reset to zero by pressing the [Up] button for 5 seconds. If it is not reset, the timer will run to a maximum of 9999 hours and then stay there until it is reset.

A timer alert can be set from 100 - 2000 hours to indicate that a service intervention is required, for example. The Service LED lights continuously when the number of hours set for the timer alert is reached. Resetting the timer to zero switches off the Service LED.

Gobos

The gobos fitted to the MAC 350 Entour as standard are illustrated in Figure 6 on page 19. All gobos are interchangeable.

Custom gobos

Martin can provide additional gobos for the MAC 350 Entour. For more information, please visit the Martin web site at www.martin.com.

Glass gobos are generally the most durable, but satisfactory results can be obtained at less expense with aluminum gobos. Custom stainless steel gobos can also be used, but they can warp, losing sharpness, in a matter of hours. Their useful life will depend on the gobo pattern and the projection cycle. Consult your gobo supplier for more information.

For best results, custom gobos should meet the specifications listed under “Gobos” on page 44.

Gobo orientation in the MAC 350 Entour

Most gobos must be installed facing in a certain direction in order to avoid heat damage. All MAC 350 Entour gobos **MUST** be installed with the more reflective side towards the LEDs, or they will absorb too much heat and be damaged. Consult your Martin dealer or gobo supplier if you are in any doubt about the orientation of a specific gobo type.

Coated Glass Gobos

Focus is easiest to maintain if all coated gobos in a fixture are installed with their coatings as close as possible to the same plane of focus. However, the first priority is normally to ensure that the more reflective side faces towards the LEDs.

More reflective side towards LEDs

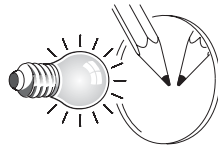

To minimize the risk of gobo overheating and damage, turn the more reflective side of a coated gobo towards the LEDs.

Less reflective side away from LEDs

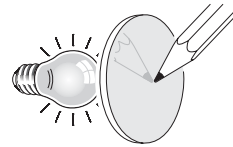

The less reflective side of a coated gobo will absorb less heat if it faces away from the LEDs.

To determine which side of a gobo is coated, hold an object up to it. On the uncoated side, there is a space between the object and its reflection and the edge of the gobo can be seen when looking through the glass.

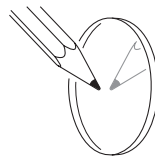

Uncoated side

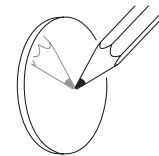

Coated side

Textured Glass Gobos

Smooth side towards LEDs

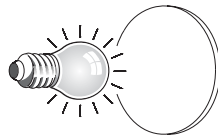

Textured side away from LEDs

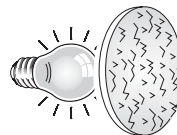

Textured glass gobos in the MAC 350 Entour give the best focus results with the smooth side towards the LEDs. If in doubt, consult your Martin dealer or gobo supplier.

Metal Gobos

Reflective side towards LEDs

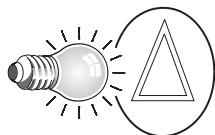

Black side away from LEDs

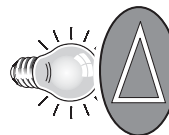

Image / text Gobos

True image towards LEDs



Reversed image away from LEDs



Custom gobos must be designed so that the true image appears on the more reflective side so that it faces the LEDs when installed.

Figure 8. Correct gobo orientation

Effects access hatch and changing gobos and filters



WARNING! Hot surfaces. The MAC 350 Entour becomes hot in use. Either dim LEDs to zero and allow to cool for 20 minutes or wear clean lint-free heat-resistant gloves before opening the access hatch.

Effects access hatch

The MAC 350 Entour effects hatch (see Figure 9) gives instant access to gobos and color filters.

Pan and tilt are disabled and **EFHA** appears in the fixture display as soon as the hatch is opened.

If the fixture is powered on, flipping the hatch closed and immediately open again advances one position on first the gobo wheel and then the color wheel, giving access to each gobo and filter in turn.

To close the hatch, apply firm pressure until you feel a definite click. When the hatch stays closed for more than a second, the gobo and color wheels reset to their start positions.

The hatch can be removed temporarily by unclipping it from its hinge posts, but it is a very tight fit and care must be taken to avoid damaging the clips or posts. Removal should not normally be necessary.

Note that if the hatch is not fully closed, it will be impossible to use pan and tilt or reset the fixture.

Changing gobos and filters

Wear gloves while handling optical components and use only genuine Martin parts.

Keep all optical components totally clean and free of grease. Clean them with 99.9% isopropyl alcohol, especially if you touch them with your fingers.

To gain access to the optical and effects components in the head for cleaning and service:

1. Put on clean lint-free heat-resistant gloves to protect your fingers and avoid getting oil on optical components
2. See Figure 9. Flip the effects access hatch open.

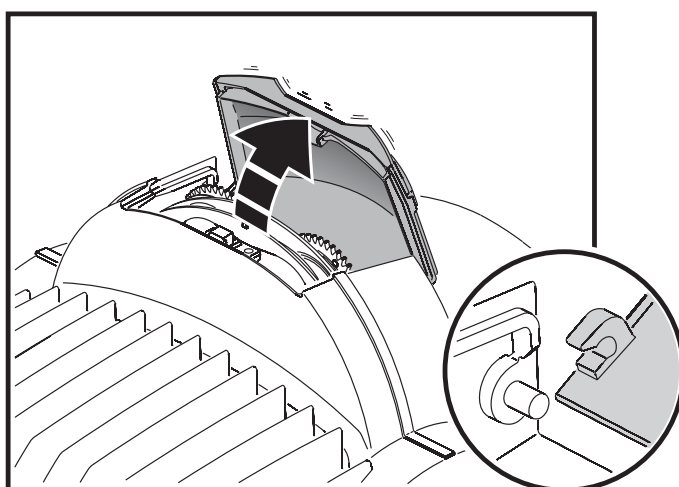

Figure 9: Effects access hatch

3. To remove a rotating gobo, pull it gently towards the lens until you can slide it up and out of the two leaf springs that secure it.
4. To install a gobo, slide the flange on the edge of the gobo down between the springs and the gobo wheel until the gobo can be located in its aperture in the gobo wheel. Check that it is held securely and that the teeth around the edge of the gobo are engaged in the cog in the center of the gobo wheel.
5. To remove a color filter, turn the gobo wheel so that the open position (arrowed in Figure 10) is in front of the filter. Gently press the filter towards the lens to release it and then grasp it by the edges and remove it. If your fingers are too large, protect the glass with a piece of paper that has been folded several times and grasp the filter with needle nose pliers.
6. To install a color filter, slide it under the retention spring until it snaps into place.
7. Close the access hatch, pressing firmly until there is a definite click.

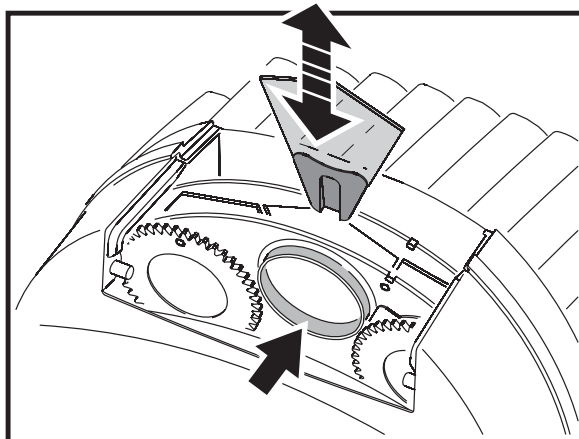

Figure 10: Changing gobos and filters

Replacing rotating gobos

Important! *The gobo can fall out if the spring is inserted the wrong way round.*

The gobos are held in goboholders by a retention spring (see Figure 11). Note that the retention spring can only be used with gobos maximum 3 mm thick. Thicker gobos can be glued to the holder with a UV adhesive or Loctite 330 Multibond with Activator.

To replace a rotating gobo

1. Put on clean, lint-free, heat-resistant gloves to protect your fingers and avoid getting oil on optical components
2. Remove the gobo as described on page 27.
3. With a small screwdriver or similar, unhook the end of the gobo spring furthest from the gobo and pull out the spring. Drop the gobo out of the holder.
4. Insert the new gobo in the holder with the side that faces towards the LEDs facing upwards, towards the spring (see Figure 8 and Figure 11).
5. Insert the spring with the narrow end against the gobo, as shown in Figure 11. To identify the narrow end, press the spring flat: the narrow end is on the inside. Push the end of the spring in under the lip of the holder.
6. Check that the gobo is seated flush against the holder. Press the spring as flat as possible against the back of the gobo.
7. Work the rim of the goboholder under both clips on the gobo wheel until you can snap the goboholder back into position. If necessary, lever the clips away from the wheel slightly with a small screwdriver or similar tool.
8. Close the access hatch, pressing firmly until there is a definite click.

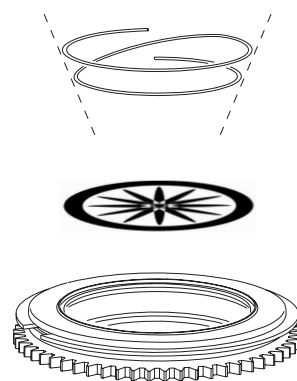

Figure 11: Rotating goboholder

Calibrating effects

1. Apply power.
2. To calibrate focus, first remove the bottom head cover. Select **SERV**→**CAL**→**FOCU** and press [Enter]. Run the focus car to the rearmost limit of its travel (i.e. furthest back towards the LEDs) where it is pressing both end stop switches fully closed. Adjust the focus car forwards slightly until you hear an audible click from the end stop switches as they open. Press [Enter] to save the setting. Replace the bottom head cover.
3. Pan calibration is easiest when multiple fixtures are stacked vertically. To calibrate, set tilt positions for easy one-over-the-other comparison and set each fixture to the same pan DMX value. Select one fixture

to be the reference fixture. On the other fixtures, select **SERV**→**CAL**→**P OF** and press [Enter]. Adjust the offset as necessary to align the beam with the reference beam. Press [Enter] to save the setting.

4. Tilt calibration is easiest when multiple fixtures are arranged horizontally. To calibrate, set pan positions for easy side-by-side comparison and set each fixture to the same tilt DMX value. Select one fixture to be the reference fixture. On the other fixtures, select **SERV**→**CAL**→**T OF** and press [Enter]. Adjust the offset as necessary to align the beam with the reference beam. Press [Enter] to save the setting.

Cleaning

Regular cleaning is essential in order to obtain optimum fixture life and performance. Buildup of dust, dirt, smoke particles, fog fluid residues, etc. degrades the fixture's light output and cooling ability.

Cleaning schedules for lighting fixtures vary greatly depending on the operating environment. It is therefore impossible to specify precise cleaning intervals for the MAC 350 Entour. Environmental factors that may result in a need for frequent cleaning include:

- Use of smoke or fog machines.
- High airflow rates (near air conditioning vents, for example).
- Presence of cigarette smoke.
- Airborne dust (from stage effects, building structures and fittings or the natural environment at outdoor events, for example).

If one or more of these factors is present, inspect fixtures within their first 100 hours of operation to see whether cleaning is necessary. Check again at frequent intervals. This procedure will allow you to assess cleaning requirements in your particular situation. If in doubt, consult your Martin dealer about a suitable maintenance schedule.

Use care when cleaning optical components and work in a clean, well lit area. The coated surfaces are fragile and easily scratched. Do not use solvents that can damage plastic or painted surfaces.

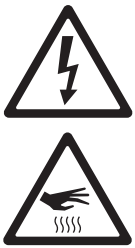

WARNING! Disconnect from power and allow to cool before cleaning.

To clean the fixture:

1. Disconnect the fixture from power and allow it to cool for at least 20 minutes.
2. Remove the head covers.
3. Vacuum or gently blow away dust and loose particles with compressed air.
4. Remove dust from the head with a soft brush, cotton swab, vacuum, or compressed air.
5. Carefully clean the optical components. Remove smoke and other residues with cotton swabs or unscented tissues moistened with isopropyl alcohol. A commercial glass cleaner may be used, but residues must be removed with distilled water. Clean with a slow circular motion from center to edge. Dry with a clean, soft and lint-free cloth or compressed air. Remove stuck particles with an unscented tissue or cotton swab moistened with glass cleaner or distilled water. Do not rub the surface: lift the particles off with a soft repeated press.
6. Reinstall all covers before applying power

Lubrication

In general, the MAC 350 Entour does not require lubrication. However, depending on use conditions, the bushes and slider bars for the focus car may eventually require reapplication of the long-lasting teflon-based grease applied at the factory. Noise when operating the focus is a sign that lubrication is required. This operation can be carried out by a Martin service partner if necessary.

Do not lubricate plastic bushes.

Fuse replacement

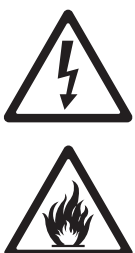

WARNING! Disconnect from power before opening covers. Replace fuses with ones of the same type and rating only. Never bypass or bridge a fuse.

The MAC 350 Entour™ is protected by two 10 AT (slow-blow) mains fuses located in fuseholders next to the power cable entry (see Figure 1 on page 8).

To replace a fuse:

1. Isolate the fixture from power.
2. Use a flathead screwdriver to open the fuseholders and remove the fuses for testing or replacement.

3. Replace defective fuses with ones of the same type and rating only. Replacement fuses are available from Martin.
4. Reinstall the fuseholders before reapplying power.

If a fuse blows repeatedly, disconnect the fixture from power immediately and consult your Martin supplier.

A 5 amp slow-blow fuse is located on the PSU. This fuse is not user-replaceable and must be changed by Martin Global Service or its authorized agents observing appropriate safety and ESD (electrostatic discharge) precautions.

Firmware installation

Firmware (i.e. fixture software) updates are available from the Martin web site at www.martin.com and can be installed via the data link with a Martin upload device.

The following are required in order to install fixture software:

- The latest version of the MAC 350 Entour firmware in the form of an MU3 file, available for download from the User Support Area of the Martin web site at <http://www.martin.com/service>
- The Martin Software Uploader application, version 5.0 or later, available for download from the User Support Area of the Martin web site.
- A PC running Windows 2000/XP
- A PC-DMX interface supported by the Martin Software Uploader application (Martin Universal USB/DMX Interface recommended). Note that the Martin MP2 (a configuration tool that was sold by Martin but is no longer available) is not supported by the MAC 350 Entour.

Installing new fixture software

To install new software, connect a PC with the Martin Uploader application and the MAC 350 Entour fixture software to the MAC 350 Entour's DMX input connector via a Martin Universal USB/DMX Interface box or similar interface.

All the MAC 350 Entour fixtures that are powered on and connected to the DMX data link should accept the new software. There is no need to isolate MAC 350 Entours from other types of fixture on the data link.

Normal upload

A MAC 350 Entour should automatically enter software upload mode when it is connected as described above. If it does not, use **SERV**→**UPLD** in the control menu to prepare the fixture for the upload. Carry out the upload in Auto/DMX mode as described in the Uploader application help file.

If the display and control panel are unusable because the software has become corrupted, carry out a boot mode upload (see below).

Boot mode upload

Carry out a boot mode upload only if the fixture software is totally corrupted (which is evident if the control panel does not respond when power is applied) or if the software update notes call for a boot sector update. To carry out a boot mode upload:

1. Disconnect the fixture from power.
2. Remove the right-hand side cover from the yoke to expose the main PCB (right-hand as seen from the LED end of the head with the text on the rear of the head the right way up).
3. See Figure 12. Locate the 6-pin DIP-switch on the PCB and move pin 6 to **ON** (boot mode upload enable).
4. Reapply power, upload the software, and disconnect from power.
5. Move DIP-switch pin 6 back to **OFF** (Normal) and reinstall the yoke side cover.

If a checksum error occurs when powering on after performing a boot mode upload, carry out a normal upload as described above.

Circuit board layout

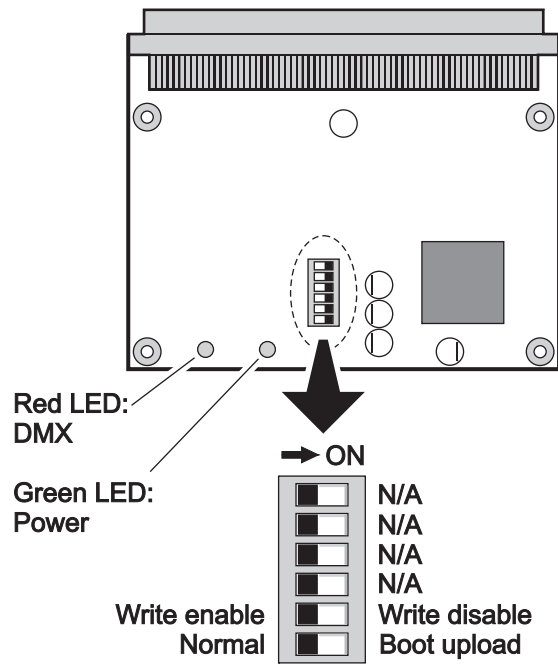

Figure 12: Main PCB and DIP switch

The MAC 350 Entour has a large fan on the back of the head. Two types of this fan are installed at the factory, one with 2 and one with 3 wires. Airflow, cooling effect and noise levels are exactly the same for both types of fan. On fixtures with the two-wire fan, DIP switch pin 1 on the main PCB must be set to the **ON** position and all the other pins set to **OFF** in normal operation. On fixtures with the three-wire fan, all DIP switch pins must be set to the **OFF** position in normal operation.

MAC 350 Entour DMX protocol

8-bit mode	16-bit mode	DMX Value	Percent	Function		
1	1	0 - 19	0 - 19	Electronic shutter effect, strobe (snap) Shutter closed		
		20 - 49	20 - 49	Shutter open		
		50 - 64	50 - 64	Strobe 1, fast → slow		
		65 - 69	65 - 69	Shutter Open		
		70 - 84	70 - 84	Strobe 2, fast → slow - Opening Pulse		
		85 - 89	85 - 89	Shutter Open		
		90 - 104	90 - 104	Strobe 3, fast → slow - Closing Pulse		
		105 - 109	105 - 109	Shutter Open		
		110 - 124	110 - 124	Strobe 4, fast → slow - Random Strobe		
		125 - 129	125 - 129	Shutter Open		
		130 - 144	130 - 144	Strobe 5, fast → slow - Random Opening Pulse		
		145 - 149	145 - 149	Shutter Open		
		150 - 164	150 - 164	Strobe 6, fast → slow - Random Closing Pulse		
		165 - 169	165 - 169	Shutter Open		
		170 - 184	170 - 184	Strobe 7, fast → slow - Burst Pulse		
		185 - 189	185 - 189	Shutter Open		
		190 - 204	190 - 204	Strobe 8, fast → slow - Random Burst Pulse		
		205 - 209	205 - 209	Shutter Open		
		210 - 224	210 - 224	Strobe 9, fast → slow - Electronic Sinewave		
		225 - 229	225 - 229	Shutter Open		
		230 - 244	230 - 244	Strobe 10, fast → slow - Electronic Burst		
		245 - 255	245 - 255	Shutter Open		
		2	2	0 - 255	0 - 100	Intensity (fade) Zero → full
		3	3	0	0	Color wheel position and rotation, music trig color chase Continuously scrolling color wheel positions Open (white)
				1-15	0 - 6	Open → Color 1
16	6			Color 1 (Blue)		
17 - 31	7 - 12			Color 1 → Color 2		
32	13			Color 2 (Green)		
33 - 47	13 - 18			Color 2 → Color 3		
48	19			Color 3 (Orange)		
49 - 63	19 - 25			Color 3 → Color 4		
64	25			Color 4 (Yellow)		
65 - 79	25 - 31			Color 4 → Color 5		
80	31			Color 5 (Pink)		
81 - 95	32 - 37			Color 5 → Color 6		
96	38			Color 6 (Magenta)		
97 - 111	38 - 44			Color 6 → Color 7		
112	44			Color 7 (Congo)		
113 - 127	44 - 50			Color 7 → Color 8		
128	50			Color 8 (Red)		
129 - 143	51 - 56			Color 8 → Open		
144	56			Open		
145 - 148	57 - 58			Stepped scroll (indexed) color wheel positions Color 8 (Red)		
149 - 152	59 - 60			Color 7 (Congo)		
153 - 156	60 - 61			Color 6 (Magenta)		
157 - 160	62 - 63			Color 5 (Pink)		
161 - 164	63 - 64			Color 4 (Yellow)		
165 - 168	65 - 66			Color 3 (Orange)		
169 - 172	66 - 67			Color 2 (Green)		
173 - 176	68 - 69			Color 1 (Blue)		
177 - 180	69 - 71			Open		
181 - 203	71 - 79			Continuous color wheel rotation CW, fast → slow		
204 - 207	80			Color wheel stop		
208 - 230	81 - 90			CCW, slow → fast		
231 - 235	91 - 92			Music triggered color chase Fast		
236 - 239	93 - 94			Medium		
240 - 243	94 - 95	Slow				
244 - 247	96 - 97	Random color chase Fast				
248 - 251	97 - 98	Medium				
252 - 255	99 - 100	Slow				

Table 3: DMX Protocol

8-bit mode	16-bit mode	DMX Value	Percent	Function
4	4	0 - 3	0 - 1	Rotating gobo selection and shake
		4 - 7	2 - 3	Indexing (set position on channel 5; set fine position on channel 6 in 16 bit mode)
		8 - 11	3 - 4	Open gobo
		12 - 15	5 - 6	Gobo 1 (Jessica Rose)
		16 - 19	6 - 7	Gobo 2 (Cathedral Spikes)
		20 - 23	8 - 9	Gobo 3 (Galaxy Breakup)
		24 - 27	9 - 11	Gobo 4 (Fabrick)
				Gobo 5 (Dipple)
				Gobo 6 (Blue Ripple)
				Rotation (set rotation speed on channel 5)
				Open gobo
				Gobo 1 (Jessica Rose)
				Gobo 2 (Cathedral Spikes)
				Gobo 3 (Galaxy Breakup)
				Gobo 4 (Fabrick)
				Gobo 5 (Dipple)
				Gobo 6 (Blue Ripple)
				Indexed gobo shake (set indexed gobo position on channel 5)
				Gobo 1 shake, slow → fast
				Gobo 2 shake, slow → fast
				Gobo 3 shake, slow → fast
				Gobo 4 shake, slow → fast
				Gobo 5 shake, slow → fast
				Gobo 6 shake, slow → fast
				Rotating gobo shake (set rotation speed on channel 5)
				Gobo 6 shake, slow → fast
				Gobo 5 shake, slow → fast
		Gobo 4 shake, slow → fast		
		Gobo 3 shake, slow → fast		
		Gobo 2 shake, slow → fast		
		Gobo 1 shake, slow → fast		
		Continuous gobo wheel scroll (set gobo rotation speed on channel 5)		
		CW slow → fast		
		CCW fast → slow		
		Music triggered gobo chase		
		Fast		
		Medium		
		Slow		
5	5	0 - 255	0 - 100	Gobo rotation (select gobo on channel 4)
				Indexed position
				0 - 395°
				Continuous rotation direction and speed
		0 - 2	0 - 1	No rotation
		3 - 121	1 - 47	CW, slow → fast
		122 - 240	48 - 94	CCW, fast → slow
241 - 243	95 - 95	No rotation		
		Music triggered gobo rotation		
		Fast		
		Medium		
		Slow		
-	6	0 - 255	0 - 100	Gobo rotation, fine
6	7	0-199	0 - 77	Iris (fade)
		200-215	78 - 84	Open → closed
		216-229	85 - 89	Closed
		230-243	90 - 94	Opening pulse, Fast → Slow
		244-249	95 - 97	Closing pulse, fast → slow
		250-255	98 - 100	Random opening pulse, fast → slow
		Random closing pulse, fast → slow		
7	8	0 - 255	0 - 100	Focus (fade)
				Infinity → 2 meters

Table 3: DMX Protocol

8-bit mode	16-bit mode	DMX Value	Percent	Function
8	9	0 - 5	0 - 2	Pan/tilt macros
		6 - 11	2 - 4	No Macro
		12 - 17	5 - 7	Macro 1.1
		18 - 23	7 - 9	Macro 1.2
		24 - 29	9 - 11	Macro 1.3
		30 - 35	12 - 14	Macro 1.4
		36 - 41	14 - 16	Macro 2.1
		42 - 47	16 - 18	Macro 2.2
		48 - 53	19 - 21	Macro 2.3
		54 - 59	21 - 23	Macro 2.4
		60 - 65	24 - 25	Macro 3.1
		66 - 71	26 - 28	Macro 3.2
		72 - 77	28 - 30	Macro 3.3
		78 - 83	31 - 33	Macro 3.4
		84 - 89	33 - 35	Macro 4.1
		90 - 95	35 - 37	Macro 4.2
		96 - 101	38 - 40	Macro 4.3
		102 - 107	40 - 42	Macro 4.4
		108 - 113	42 - 44	Macro 5.1
		114 - 119	45 - 47	Macro 5.2
		120 - 125	47 - 49	Macro 5.3
		126 - 131	49 - 51	Macro 5.4
		132 - 137	52 - 54	Macro 6.1
		138 - 143	54 - 56	Macro 6.2
		144 - 149	56 - 58	Macro 6.3
		150 - 155	59 - 61	Macro 6.4
		156 - 161	61 - 63	Macro 7.1
		162 - 167	64 - 65	Macro 7.2
		168 - 173	66 - 68	Macro 7.3
		174 - 179	68 - 70	Macro 7.4
		180 - 185	71 - 73	Macro 8.1
		186 - 191	73 - 75	Macro 8.2
		192 - 197	75 - 77	Macro 8.3
		198 - 203	78 - 80	Macro 8.4
204 - 209	80 - 82	Macro 9.1		
210 - 215	82 - 84	Macro 9.2		
216 - 221	85 - 87	Macro 9.3		
222 - 227	87 - 89	Macro 9.4		
228 - 233	89 - 91	Macro 10.1		
234 - 239	92 - 94	Macro 10.2		
240 - 245	94 - 96	Macro 10.3		
246 - 255	96 - 100	Macro 10.4		
			Reserved (no effect)	

Table 3: DMX Protocol

8-bit mode	16-bit mode	DMX Value	Percent	Function
9	10	0 - 5	0 - 2	Effects macros
		6 - 11	2 - 4	No Macro
		12 - 17	5 - 7	Macro 1.1
		18 - 23	7 - 9	Macro 1.2
		24 - 29	9 - 11	Macro 1.3
		30 - 35	12 - 14	Macro 1.4
		36 - 41	14 - 16	Macro 2.1
		42 - 47	16 - 18	Macro 2.2
		48 - 53	19 - 21	Macro 2.3
		54 - 59	21 - 23	Macro 2.4
		60 - 65	24 - 25	Macro 3.1
		66 - 71	26 - 28	Macro 3.2
		72 - 77	28 - 30	Macro 3.3
		78 - 83	31 - 33	Macro 3.4
		84 - 89	33 - 35	Macro 4.1
		90 - 95	35 - 37	Macro 4.2
		96 - 101	38 - 40	Macro 4.3
		102 - 107	40 - 42	Macro 4.4
		108 - 113	42 - 44	Macro 5.1
		114 - 119	45 - 47	Macro 5.2
		120 - 125	47 - 49	Macro 5.3
		126 - 131	49 - 51	Macro 5.4
		132 - 137	52 - 54	Macro 6.1
		138 - 143	54 - 56	Macro 6.2
		144 - 149	56 - 58	Macro 6.3
		150 - 155	59 - 61	Macro 6.4
		156 - 161	61 - 63	Macro 7.1
		162 - 167	64 - 65	Macro 7.2
		168 - 173	66 - 68	Macro 7.3
		174 - 179	68 - 70	Macro 7.4
		180 - 185	71 - 73	Macro 8.1
		186 - 191	73 - 75	Macro 8.2
192 - 197	75 - 77	Macro 8.3		
198 - 203	78 - 80	Macro 8.4		
204 - 209	80 - 82	Macro 9.1		
210 - 215	82 - 84	Macro 9.2		
216 - 221	85 - 87	Macro 9.3		
222 - 227	87 - 89	Macro 9.4		
228 - 233	89 - 91	Macro 10.1		
234 - 239	92 - 94	Macro 10.2		
240 - 245	94 - 96	Macro 10.3		
246 - 255	96 - 100	Macro 10.4		
				Reserved (no effect)
10	11	0 - 255	0 - 100	Pan Full left → full right (128 = neutral)
-	12	0 - 255	0 - 100	Pan, fine (least significant byte) Left → right
11	13	0 - 255	0 - 100	Tilt Full tilt → full opposite tilt (128 = neutral)
-	14	0 - 255	0 - 100	Tilt, fine (least significant byte) Tilt → opposite tilt
12	15	0 - 2	0 - 1	Pan/tilt speed Tracking mode
		3 - 245	1 - 95	Vector mode, fast → slow
		246 - 251	96 - 98	Reserved for future use
		252 - 255	99 - 100	Blackout while moving

Table 3: DMX Protocol

8-bit mode	16-bit mode	DMX Value	Percent	Function
13	16	0 - 2	0 - 1	Effects speed
		3 - 245	1 - 96	Shutter, focus
		246 - 251	96 - 98	Tracking mode
		252 - 255	99 - 100	Vector mode, fast → slow
				Tracking mode
				Vector mode, maximum speed
				Color
		0 - 2	0 - 1	Tracking mode
		3 - 245	1 - 96	Vector mode, fast → slow
		246 - 248	96 - 97	Tracking mode, SCUT = OFF (overrides ON if set via control menu)
		249 - 251	98	Tracking mode, SCUT = ON (overrides OFF if set via control menu)
		252 - 255	99 - 100	Blackout while moving
				Gobo selection
		0 - 245	0 - 1	Normal (no blackout)
		246 - 248	1 - 96	Normal, SCUT = OFF (overrides ON if set via control menu)
		249 - 251	96 - 98	Normal, SCUT = ON (overrides OFF if set via control menu)
252 - 255	99 - 100	Blackout while moving		
		Indexed gobo rotation (if indexed position selected on channel 4)		
0 - 2	0 - 1	Tracking mode		
3 - 245	1 - 96	Vector mode, fast → slow		
246 - 251	96 - 98	Tracking mode		
252 - 255	99 - 100	Blackout while moving		
14	17	0 - 9	0 - 1	Fixture control settings (snap)
		10 - 14	2 - 3	No function
		15 - 19	4 - 5	Reset entire fixture ¹
		20 - 24	6 - 7	No function
		25 - 29	8 - 9	Reset effects only ¹
		30 - 34	10 - 11	No function
		35 - 39	12 - 13	Reset pan & tilt only ¹
		40 - 44	14 - 15	No function
		45 - 49	16 - 17	Pan/tilt speed = NORM ²
		50 - 54	18 - 19	Pan/tilt speed = FAST ²
		55 - 59	20 - 21	Pan/tilt speed = SLOW ²
		60 - 64	22 - 23	Reserved for future use
		65 - 69	24 - 25	No function
		70 - 74	26 - 27	Fan mode = Full ²
		75 - 79	28 - 29	No function
		80 - 84	30 - 31	Fan mode = Regulated ²
		85 - 89	32 - 33	No function
		90 - 94	34 - 35	Fan mode = Silent ²
		95 - 99	36 - 37	No function
		100 - 104	38 - 39	Dimmer curve = LIN ²
		105 - 109	40 - 41	No function
		110 - 114	42 - 43	Dimmer curve = SQR ²
		115 - 119	44 - 45	No function
		120 - 124	46 - 47	Dimmer curve = ISQR ²
		125 - 129	48 - 49	No function
		130 - 134	50 - 51	Dimmer curve = SCUR ²
		135 - 139	52 - 53	No function
		140 - 144	54 - 55	Calibrated output ²
		145 - 149	56 - 57	No function
		150 - 154	58 - 59	Raw output (maximum possible, non-calibrated) ²
		155 - 249	60 - 97	No function
		250 - 255	98 - 100	Reserved for future use
		Illuminate display		

Channel Notes

¹ If DMX Reset is disabled in the menu, a reset command can only be executed if channel 2 is set to 232 and channel 1 is set to zero.

² Menu override. Setting not affected by cycling power off/on.

Table 3: DMX Protocol

Control menu

Menu	Item	Options	Notes (Default settings in bold print)
ADDR		1 – 501	DMX address (default address = 1). Limited to 496 in 16-bit DMX mode.
		8BT	8-bit DMX mode
PSET		16BT	16-bit DMX mode with 2-channel (coarse and fine) control of gobo rotation, pan and tilt
		PTSP	NORM , FAST and SLOW pan/tilt speed
PERS	PTST	SWAP	OFF = Normal pan and tilt control ON = Map DMX pan control to tilt channel and vice versa
		PINV	OFF = Normal pan control: left → right ON = Reverse DMX pan control: right → left
		TINV	OFF = Normal tilt control: up → down ON = Reverse DMX tilt control, down → up
		NORM	Normal effects speed
	EFSP	FAST	Optimize effects movement for speed (gives slightly reduced smoothness)
		SLOW	Optimize effects movement for smoothness (gives slightly reduced pan/tilt speed)
		PTSS	Pan/tilt speed slave: effects speed copies the pan/tilt speed that has been set via the control menu or via DMX
	FANS	REG	Temperature-regulated fan operation
		FULL	All fans set to full speed
		SLNT	Silent mode. When Silent mode is selected the head fan will turn off. The base fan will still run. LED output will be limited to prevent the fixture from producing too much heat. If the LEDs get too hot the fans will revert to Regulated mode. When the LEDs are cool enough the fans shift back to Silent mode.
	DIM	LIN	Linear dimming curve
		SQR	Square law dimming curve
		ISQR	Inverse square law dimming curve
		SCUR	S-curve dimming curve
	DRES	OFF	Disable reset via DMX
		ON	Enable reset via DMX
	SCUT	OFF	Effect wheels do not cross open
		ON	Effect wheels move shortest distance (even if this means crossing open position)
	DISP	ON	Display on permanently
		2 M	Display auto-sleeps and menu returns to top level after 2 mins.
10M		Display auto-sleeps and menu returns to top level after 10 mins.	
2 ME		Display auto-sleeps and menu returns to top level after 2 mins., display is reactivated by error messages	
10ME		Display auto-sleeps and menu returns to top level after 10 mins., display is reactivated by error messages	
DINT		Display intensity 100% - 10% (default = 50%)	
ERRM	NORM	Display errors at 100% intensity (regardless of DINT setting) and illuminate the service light.	
	SLNT	Silent error mode. The error message does not appear in the display, but the service light is illuminated	
LCAL	CAL	Output set to maximum default value respecting calibration limits	
	MAX	Calibration ignored and output set to maximum Note: fixture output may not match evenly between fixtures at this setting.	

Table 4: Control menu

Menu	Item	Options	Notes (Default settings in bold print)
SA	RUN	ENA	Enable stand-alone execution
		DIS	Disable stand-alone execution
	SAE	SIN	Single fixture mode
		MAS	Master mode
		SLA	Synchronized (slave) mode
	PROG	SHUT	Shutter: open / close / fade in / fade out / strobe fast / strobe medium / strobe slow / random fast / random medium / random slow / music trig
		INT	Intensity zero - 100%
		COL	Color: open / colors 1 - 8 / rotation direction and speed / music trig / random fast - slow
		GOBO	Gobos: open / gobos 1 - 6 indexed position / gobos 1 - 6 rotation / gobos 1 - 6 shake, speed / gobo wheel rotation direction and speed / music trig speed
		RGBO	Rotating gobo speed
		IRIS	Iris: open / closed / opening pulse fast & slow / closing pulse fast & slow / random open fast & slow / random close fast & slow
		FOCU	Focus
		PTMA	Pan/tilt macros 1.1 - 10.4
		EFMA	Effects macros 1.1 - 10.4
		PAN	Pan
		TILT	Tilt
		FADE	Fade time hours / minutes / seconds
		WAIT	Wait time hours / minutes / seconds
		NEXT	Call up next scene
		PREV	Call up previous scene
		ADD	Add scene to the end of the sequence
		STOR	Save changes to current scene.
		INS	Insert scene before current scene
		DEL	Delete current scene
		CLR	Delete all scenes in sequence
	VIEW	Preview sequence	
		GDMX	Get DMX (load the scene currently being sent by DMX into stand-alone memory – see Table 5 on page 40 for details).
FACT	FACT	LOAD	Return all settings (except calibrations) to factory defaults <i>NB: can take up to 2 minutes to complete!</i>
	CUS1, CUS2, CUS3	LOAD	Load custom configuration
		SAVE	Save current custom configuration
INFO	VERS	X.X.X	CPU firmware version
	FANS	LED	LED cooling fan speed in rpm
		HEAD	Head cooling fan speed in rpm
	POHR	RSET	Hours of operation since counter reset (to reset counter, display hours and press [Up] for 5 secs.)
		TOTL	Hours of operation since manufacture (non-resettable)
	MTMP	CURR	Current main PCB temperature
		MSR	Highest main PCB temperature since temperature log reset (to reset, display log and press [Up] for 5 secs.)
		MR	Highest recorded main PCB temperature (non-resettable)
	HTMP	CURR	Current head module temperature
		MSR	Highest head module temperature since temperature log reset (to reset, display log and press [Up] for 5 secs.)
		MR	Highest recorded head module temperature (non-resettable)
	LTMP	CURR	Current average LED PCB temperature.
MSR		Highest LED PCB temperature since LED temperature log reset (to reset, display log and press [Up] for 5 secs.)	
MR		Highest recorded LED PCB temperature (non-resettable)	
LPWR	CURR	Current LED power	
	MSR	Highest LED power since LED power log reset (to reset, display log and press [Up] for 5 secs.)	
	MR	Highest recorded LED power (non-resettable)	

Table 4: Control menu

Menu	Item	Options	Notes (Default settings in bold print)	
INFO (contd.)	AIRF	TOTL	0 - 9999 service timer in hours. To reset timer to zero, press [Up] for 5 secs.	
		STTM	Set service timer alert: 100 - 2000 (default = 1000).	
	SNUM	RDM	Displays fixture's unique RDM ID	
		SNUM	Displays fixture's serial number	
MAN	RST		Reset fixture	
	LED	0 - 255	LED intensity zero - 100%	
	SHUT	0 - 255	Shutter/strobing	
	COL	OPEN		Select open (white) position on color wheel
		C1 - C8		Select color 1 - color 8 on color wheel
		CW F		Clockwise rotation, fast
		CCWF		Counterclockwise rotation, fast
		CW M		Clockwise rotation, medium
		CCWM		Counterclockwise rotation, medium
		CW S		Clockwise rotation, slow
		CCWS		Counterclockwise rotation, slow
		MU F		Color wheel music trig, fast
		MU M		Color wheel music trig, medium
		MU S		Color wheel music trig, slow
		RNDF		Random color, fast
		RNDM		Random color, medium
	RNDS		Random color, slow	
	GOBO	OPEN		Select open (no gobo) position on gobo wheel
		G1I - G6I		Indexed gobo selection 1-6
		G1R - G6R		Rotating gobo selection 1-6
		G1RS - G6RS		Rotating gobo with shake selection 1-6
		CW F		Clockwise gobo wheel rotation, fast
		CCWF		Counterclockwise gobo wheel rotation, fast
		CW M		Clockwise gobo wheel rotation, medium
		CCWM		Counterclockwise gobo wheel rotation, medium
		CW S		Clockwise gobo wheel rotation, slow
		CCWS		Counterclockwise gobo wheel rotation, slow
		MU F		Gobo music trig, fast
		MU M		Gobo music trig, medium
	MU S		Gobo music trig, slow	
	RGBO	0 - 255	Gobo indexing angle / rotation speed (if indexed gobo or rotating gobo selected in MAN → GOBO)	
	EFMA	0 - 255	Effect macros 1.1 - 10.4	
	PTMA	0 - 255	Pan/tilt macros 1.1 - 10.4	
	FOCU	0 - 255	Focus, infinity → near	
	IRIS	0 - C		Iris, full open → full closed
		CLSD		Iris closed
		PLOF		Fast opening iris pulse
		PLOS		Slow opening iris pulse
		PLCF		Fast closing iris pulse
		PLCS		Slow closing iris pulse
		RDOF		Fast random opening iris pulse
		RDOS		Slow random opening iris pulse
		RDCF		Fast random closing iris pulse
	RDCS		Slow random closing iris pulse	
	PAN	0 - 255	Pan left → right	
	TILT	0 - 255	Full tilt → Full opposite tilt	
	TEST	TALL		Run test of LED effects, zoom effects and movement
T-FX			Run test of LED and zoom effects only	
TP-T			Run test of pan and tilt	
TDIS			Run test of display (light all segments for 5 seconds)	

Table 4: Control menu

Menu	Item	Options	Notes (Default settings in bold print)	
DMXL	RATE		DMX transmission speed in packets per second	
	QUAL		Percent of packets received without errors	
	STCO		Decimal value of the DMX start code	
	SHUT – EFSP		DMX value (0 - 255) received on each channel	
SERV To access this menu, hold [Enter] pressed for a few seconds	PTFB	ON	Enable pan/tilt position feedback/correction system	
		OFF	Disable pan/tilt feedback for service (this setting is not saved when fixture is reset)	
	ADJ		Effects adjustment menu (for service use: for full details of this menu, see “Adjustment submenu” on page 41)	
	CAL (OF = offset)	D OF		LED output calibration
		C OF		Color wheel calibration
		G OF		Rotating gobo wheel calibration
		GROF		Rotating gobo calibration
		I OF		Iris calibration
		F OF		Focus calibration
		P OF		Pan calibration
		T OF		Tilt calibration
	DFOF	SURE		Load factory effects calibration settings
	PCBT	SURE		PCB test: for service use only
	UPLD	SURE		Manually set fixture to receive software upload

Table 4: Control menu

DMX capture menu

The DMX capture menu in **SA → PROG → GDMX** contains the following options:

Item	Item	Item	Options	Notes
GDMX	DMX	STOR	ADD	Add the scene currently being sent by DMX to the end of the stand-alone sequence.
			INS	Insert the scene currently being sent by DMX before the current scene.

Table 5: DMX capture menu

Control panel shortcuts

The following shortcuts are available using the buttons in the MAC 350 Entour control panel:

Shortcut	Function
Hold [Menu] and press [Up]	Reset fixture
Hold [Menu] and [Enter] during fixture reset	Freeze pan and tilt
Hold [Up] and press [Down]	Invert display

Table 6: Control panel shortcuts

Adjustment submenu

The **SERV→ADJ** menu is for use by service technicians when performing adjustments.

Item	Options	Notes	
RST		Reset fixture	
HEAD	TEST	Run test sequence on all effects. For use by service technicians only	
	COL	ON S	Color wheel at sensor position
		OPEN	Color wheel at open position
		C1 - C8	Select color filter 1 - 8
		CW S – CW F	Color wheel rotation clockwise slow - fast
	GOBO	ON S	Gobo wheel at sensor position
		OPEN	Gobo wheel at open position
		G1 - G6	Select gobo 1 - 6
		CW S – CW F	Gobo wheel rotation clockwise slow - fast
	GOBR	ON S	Gobo at sensor position
		CW S – CW F	Gobo rotation clockwise slow - fast
	FOCU	NEAR	Focus to near position
		FAR	Focus to far position
	P-T	NEUT	Pan and tilt neutral positions
PNTD		Pan neutral, tilt down	
PNTU		Pan neutral, tilt up	
PLTN		Pan left, tilt neutral	
PRTN		Pan right, tilt neutral	
PLTD		Pan left, tilt down	
PRTU		Pan right, tilt up	

Table 7: Adjustment submenu

Display messages

Message	Appears when...	What to do
RST (Reset)	... the fixture is indexing effects at startup.	Wait for reset to complete.
SRST (Serial reset)	... the fixture has received a reset command via DMX.	Wait for reset to complete. You can set PERS → DRES to OFF to prevent accidental DMX reset commands.
 or * * * *	...there is no communication between the control panel and motherboard (this display appears briefly when powering the fixture on).	Check fuses. Check cable and connectors between control panel and motherboard. Reinstall fixture software. Contact Martin service if problem continues.
CSER (Check-sum error)	...a fixture software (firmware) upload is unsuccessful.	Repeat the upload. Contact Martin service personnel if problem continues.
HTSE (Head temperature sensor error) YTSE (Yoke temperature sensor error) LTCO (LED temperature cutoff)	...one of the sensors is reporting temperature above maximum or there is a problem with the temperature sensing circuit. LEDs are shut down.	Ensure free airflow around fixture. Clean fixture. Check that ambient temperature does not exceed max. permitted level. Contact Martin service personnel if problem continues.
EFHA	...the effects hatch is open and power is applied.	If you do not need access to effects, close the effects hatch to restore normal operation. If this message appears while you are trying to reset the fixture, close the effects hatch fully and start the reset again. Note that the effects hatch must be firmly clipped into the fully closed position.
MERR (Memory error)	...the EEPROM memory cannot be read.	Reset fixture. If a pan/tilt error is displayed when you attempt to reset the fixture, check that the effects hatch is fully closed. Upload new fixture software. Contact Martin service personnel if problem continues.
OPER (Onboard programming error)	...there is a software programming error.	
RAME (RAM error)	...there is a RAM error.	
COER (Color wheel error) G1ER (Gobo wheel error)	...there is a malfunction in the color wheel or gobo wheel positioning system.	
FBEP (Feedback error pan) FBET (Feedback error tilt) FBER (Feedback error pan/tilt)	...the pan and/or tilt correction systems cannot correct a loss of step (or there is a malfunction in the pan/tilt monitoring circuit such as a defective sensor). After a time-out, the head stops in a random position.	
PAER (Pan time-out) TIER (Tilt time-out) FOER (Focus time-out)	...there is a malfunction in the position indexing circuit for pan, tilt or focus. After the time-out, the fixture will establish a mechanical stop and continue to work, although calibration will be imprecise.	
HTER (Head temperature error) YTER (Yoke temperature error) TL1E - TL7E (Temperature error, LED 1 - LED7)	...there is a malfunction in one of the temperature sensing circuits.	
F1ER (F1 = large fan on back of head) F2ER (F1 = small internal fan)	...there is a fan feedback error.	
DRE1 - DRE7 (Driver error, drivers 1 - 7)	...one or more motor drivers fail.	
DPER (Display programming error)	...there is a display error.	
SL1E - SL7E (Sensor error, sensors 1 - 7)	...a sensor reports that it is short-circuited or open.	

Table 6: Display messages

Troubleshooting

Problem	Probable cause(s)	Remedy
Fixture is completely dead.	No power to fixture.	Check power and connections.
	Fuse blown.	Disconnect fixture from power. Check fuses and replace.
One or more fixtures resets correctly but responds erratically or not at all to the controller.	Fault on data link.	Inspect connections and cables. Correct poor connections. Repair or replace damaged cables.
	Data link not terminated.	Insert termination plug in output connector of the last fixture on the link.
	Incorrect fixture DMX addressing.	Check addressing on fixture and controller. Check fixture is set to correct DMX mode.
	One of the fixtures is defective and is disturbing data transmission on the link.	Unplug XLR in and out connectors and connect them directly together to bypass one fixture at a time until normal operation is regained. Have faulty fixture serviced by Martin service technician.
	XLR pin-out on fixtures does not match (pins 2 and 3 reversed).	Install a phase-reversing cable between the fixtures or swap pins 2 and 3 in the fixture that behaves erratically.
Pan and tilt freeze and FBER and EFHA messages are displayed during reset.	The reset cannot be completed because the effects hatch is not fully closed.	Close the effects hatch and start the reset again.
Time-out error after fixture reset.	Effect requires mechanical adjustment.	Disable effects feedback (see page 17). Contact Martin for service.
Fixture displays CSER when powered on.	A checksum error has occurred.	Upload new software using the normal upload procedure. Upload new software using the boot mode upload procedure. Contact Martin for service if problem persists.
Mechanical effect loses position.	Mechanical train requires cleaning, adjustment, or lubrication.	Contact Martin for service.
Light output abnormally low.	LEDs faulty or at end of service life.	Disconnect fixture and contact Martin for possible LED replacement.
LEDs cut out intermittently.	Fixture is too hot.	Ensure free airflow around fixture. Clean fixture. Check that ambient temperature does not exceed max. permitted level. If problem persists, contact Martin for service.

Table 7: Troubleshooting

Specifications

Physical

Length	377 mm (14.8 in.) including handles
Width (Base)	220 mm (8.7 in.)
Height	454 mm (17.9 in.), head horizontal
Height	471 mm (18.5 in.), head straight up
Weight	16.6 kg (36.6 lbs.)

Dynamic Effects

Shutter effect	Electronic, with regular and random pulse, burst and strobe effects
Electronic dimming	0 - 100%, choice of four dimming curves
Color wheel	8 interchangeable dichroic filters + open, full and split colors, music trig, continuous rotation, random color
Rotating gobo wheel	6 interchangeable gobos + open, indexing, continuous gobo rotation & scrolling, shake
Iris	Motorized
Focus	2 m (6.6 ft.) to infinity
Pan	630°
Tilt	300°
Adjustable pan/tilt and effects speed	

Optics

Light source	7 x Luminus CBT-90 (50 W) LEDs
LED lifetime	60 000 hours to minimum 70% luminous output*

*Manufacturer's figure obtained under manufacturer's test conditions

Control and Programming

Control options	DMX, stand-alone, synchronized (master/slave)
DMX channels	14/17
Setting and addressing	Control panel with LED display
Macro programs	10 pan/tilt and 10 effects macros, all with staggered start/chase feature
Macro selection	DMX or onboard control panel
Movement control options	Tracking and vector
Protocol	USITT DMX512/1990
Stand-alone memory	100 scenes
Stand-alone and master/slave programming	Control panel with LED display
Transceiver	RS-485
Fixture software update	Serial upload via DMX link
16-bit control	Rotating gobo indexing, pan & tilt

Photometric Data

Color temperature	6500 K
CRI (color rendering index)	70
Efficiency	55%
Efficacy	17 lumens per watt
Total output	8000 lm

Gobos

Outside diameter	27.9 mm (1.1 in.) +0/- 0.3 mm (0.01 in.)
Maximum image diameter	23 mm (0.9 in.)
Maximum thickness	1.8 mm (0.1 in.)
Recommended glass	High-temperature Borofloat or better with dichroic or enhanced aluminum coating
Recommended metal	Aluminum (steel for temporary use only)

Construction

Color	Black
Housing	UV-resistant fiber-reinforced composite and die-cast aluminum
Protection rating	IP20

Installation

Mounting points	2 pairs of 1/4-turn locks
Orientation	Any
Minimum distance to combustible materials	200 mm (7.9 in.)
Minimum distance to illuminated surfaces	0.5 m (1.6 ft.)

Connections

AC power input	Neutrik PowerCon
DMX data in/out	5-pin locking XLR

Electrical

AC power	100-240 V nominal, 50/60 Hz
Maximum total power consumption	463 W
Power supply unit	Auto-ranging electronic switch mode
Mains fuses	10 AT (slow blow) x 2
Standby power	49 W (idle mode, dimmed to zero)

Typical Power and Current

100 V, 50 Hz	418 W, 4.2 A, PF 0.996
100 V, 60 Hz	417 W, 4.2 A, PF 0.996
110 V, 60 Hz	439 W, 4.0 A, PF 0.996
120 V, 60 Hz	463 W, 3.9 A, PF 0.996
208 V, 60 Hz	405 W, 2.0 A, PF 0.971
230 V, 50 Hz	443 W, 2.0 A, PF 0.971
240 V, 50 Hz	452 W, 2.0 A, PF 0.962

Measurements made at nominal voltage. Allow for a deviation of +/- 10%.

PF = Power Factor

Thermal

Cooling	Forced air (temperature-regulated, low noise, user-definable levels)
Maximum ambient temperature (Ta max.)	40° C (104° F)
Maximum surface temperature, steady state, Ta=40° C	70° C (158° F)
Maximum surface temperature after 5 minutes of operation, Ta=40° C	70° C (158° F)
Total heat dissipation (calculated, +/- 10%)	Max. 1580 BTU/hr.

Approvals



EU safety	EN 60598-2-17, EN 62471
EU EMC	EN 55103-1, EN 55103-2, EN 55015, EN 61547
US safety, pending	UL 1573
US EMC	FCC Part 15 Class A
Canadian safety, pending	CAN/CSA E598-2-17
Canadian EMC	ICES-003 Class A
Australia/New Zealand	C-TICK N4241

Included Items

Two Omega clamp attachment brackets with 1/4-turn fasteners	P/N 91602001
Neutrik PowerCon NAC3FCA AC mains power input connector	P/N 05342804
User manual	P/N 35000242

Accessories

Adaptor, 3-pin male XLR - 5-pin female XLR, straight	P/N 11820004
Adaptor, 5-pin male XLR - 3-pin female XLR, straight	P/N 11820005
1 m DMX cable STP (1 pair), 5-pin male to 5-pin female XLR, IEC/UL-CL	P/N 91611242
2 m DMX cable STP (1 pair), 5-pin male to 5-pin female XLR, IEC/UL-CL	P/N 91611243
5 m DMX cable STP (1 pair), 5-pin male to 5-pin female XLR, IEC/UL-CL	P/N 91611244
10 m DMX cable STP (1 pair), 5-pin male to 5-pin female XLR, IEC/UL-CL	P/N 91611245
20 m DMX cable STP (1 pair), 5-pin male to 5-pin female XLR, IEC/UL-CL	P/N 91611246
1 m DMX cable STP (2 pair), 5-pin male to 5-pin female XLR, IEC/UL-CL	P/N 91611248

2 m DMX cable STP (2 pair), 5-pin male to 5-pin female XLR, IEC/UL-CL	P/N 91611249
5 m DMX cable STP (2 pair), 5-pin male to 5-pin female XLR, IEC/UL-CL	P/N 91611250
10 m DMX cable STP (2 pair), 5-pin male to 5-pin female XLR, IEC/UL-CL	P/N 91611251
20 m DMX cable STP (2 pair), 5-pin male to 5-pin female XLR, IEC/UL-CL	P/N 91611252
G-clamp	P/N 91602003
Half-coupler clamp	P/N 91602005
Quick trigger clamp	P/N 91602007
T-shaped omega bracket with quarter-turn fasteners	P/N 91602008
Omega bracket	P/N 91602001
Safety wire, universal, safe working load 50 kg (110.2 lbs.)	P/N 91604003
Four-unit flightcase for 4 x MAC 350	P/N 91510160

Related Items

Martin Universal USB/DMX Interface Box	P/N 90509008
--	--------------

Spare parts

10 AT mains fuse	P/N 05021029
----------------------------	--------------

Ordering Information

MAC 350 Entour, black, in cardboard box	P/N 90231400
---	--------------

Specifications subject to change without notice. For the latest product specifications, see www.martin.com

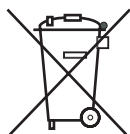

Disposing of this product

Martin™ products are supplied in compliance with Directive 2002/96/EC of the European Parliament and of the Council of the European Union on WEEE (Waste Electrical and Electronic Equipment), as amended by Directive 2003/108/EC, where applicable.

Help preserve the environment! Ensure that this product is recycled at the end of its life. Your supplier can give details of local arrangements for the disposal of Martin products.



www.martin.com • Olof Palmes Allé 18 • 8200 Aarhus N • Denmark
Tel: +45 8740 0000 • Fax +45 8740 0010