

StudioLive™ RM32AI RM16AI Applications Guide



1. General Control and Recording

Control for RM mixers is done via network control only. This can be done with either a wired Ethernet connection or wirelessly with the included USB Wi-Fi dongle.

NOTE: Recording via Ethernet (Dante or AVB) requires a wired Ethernet connection for recording and control (control will not work

with the USB Wi-Fi dongle used simultaneously with a wired Ethernet connection).

FireWire recording can be done with the FireWire 800, Dante, or AVB option cards.

Note: the FireWire cable length will limit the distance your recording computer can be from the mixer.

Contents

- 1. General Control and Recording 1
 - Dante™ 4
 - AVB..... 7
- 2. UC Surface™ for iPad's, QMix-AI for iPhone's 9
- 3. Cascaded Mixer Control and Recording 10
 - Dante™ 14
 - AVB..... 17
- 4. Remote Stage Box / Mixer Control and Recording..... 21
 - Dante™ 21
 - AVB..... 24
- 5. Multiple Autonomous 27
 - Networked Mix Systems

Ethernet Control + FireWire Recording Wireless Control via Router

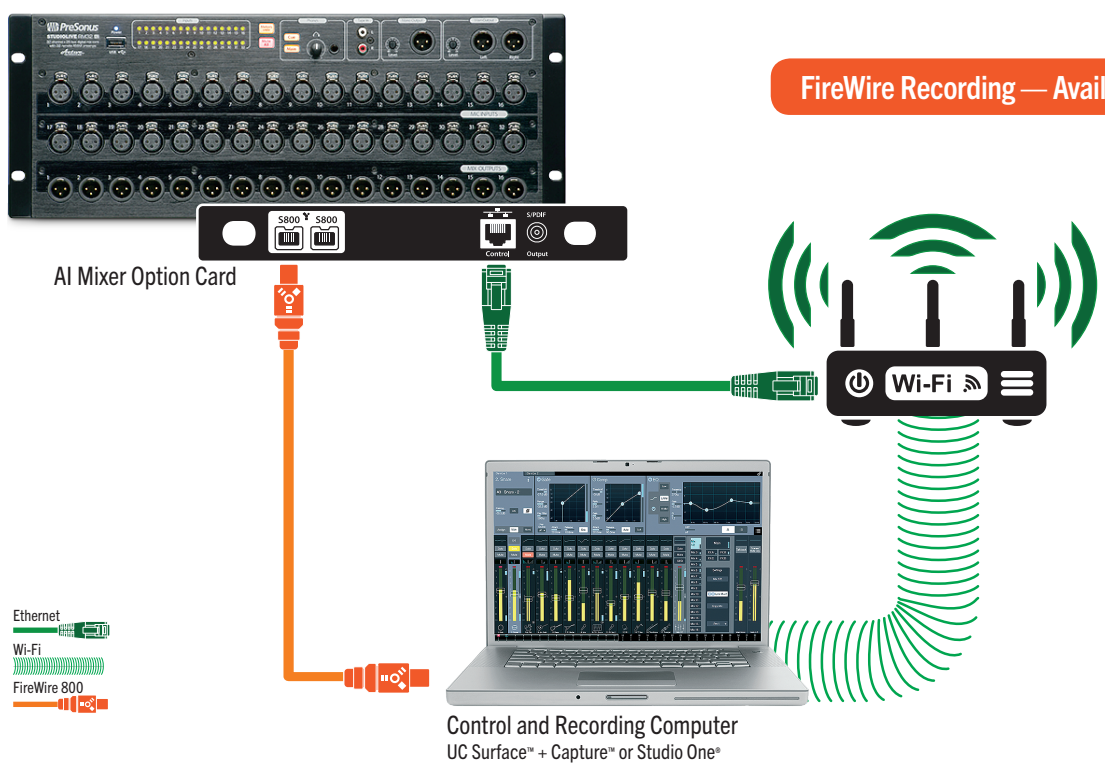

FireWire Recording — Available NOW!

Control and Recording Computer
UC Surface™ + Capture™ or Studio One®

FireWire Recording — Available NOW!

Ethernet Control + FireWire Recording | Wireless Control via Wi-Fi Dongle

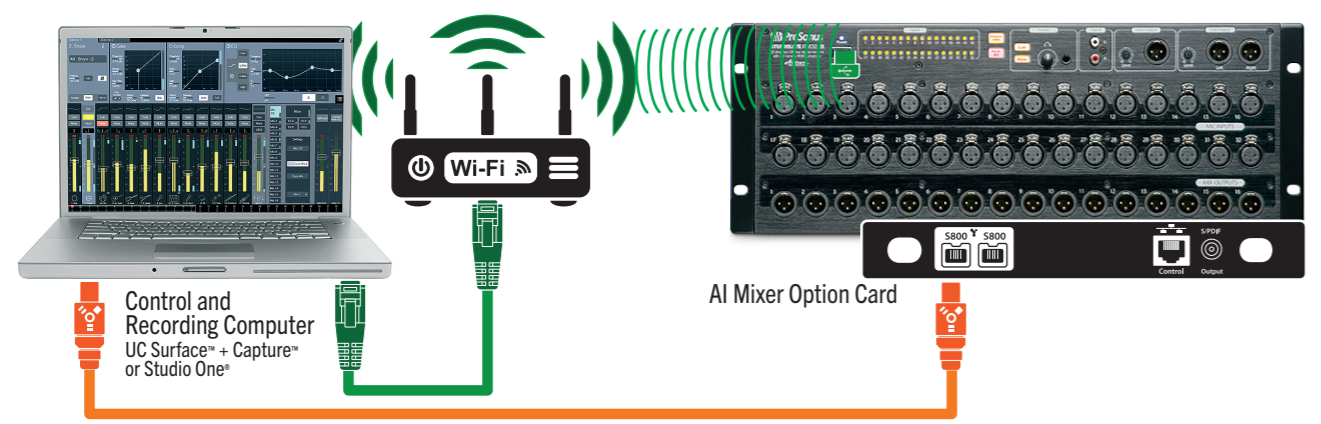

Ethernet Control + FireWire Recording | Wired Ethernet Control

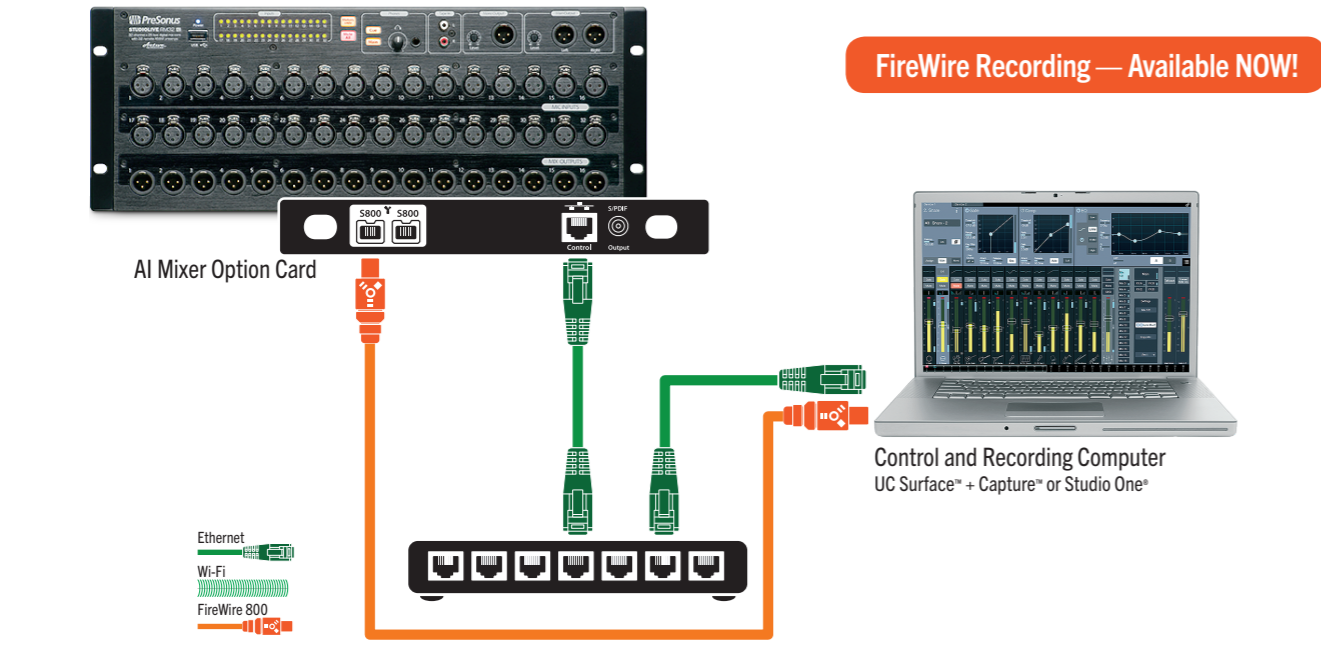

FireWire Recording — Available NOW!

Ethernet Control + FireWire Recording | Wireless Touch Screen Control via Router

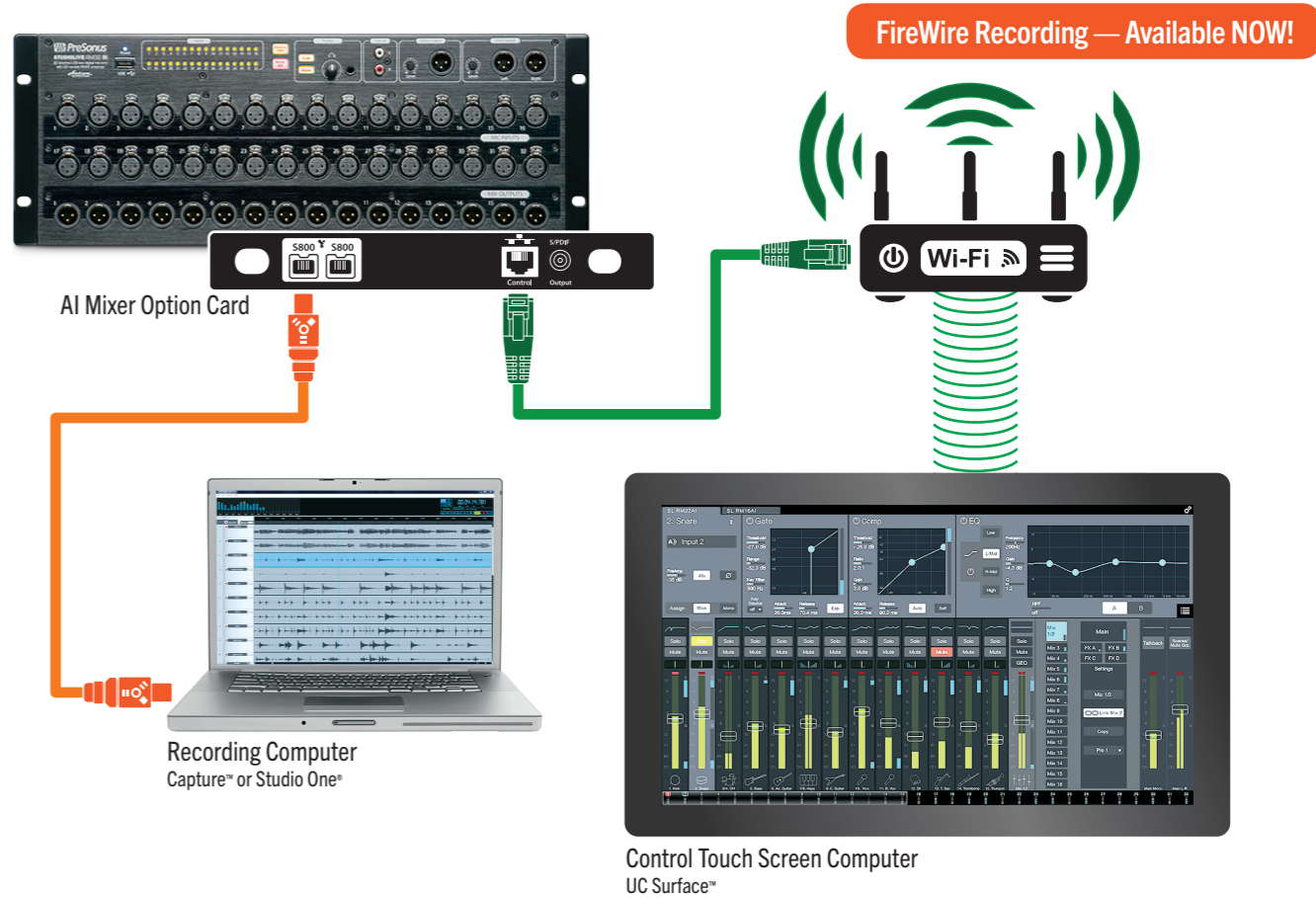

Ethernet Control + FireWire Recording | Wired Touch Screen Control

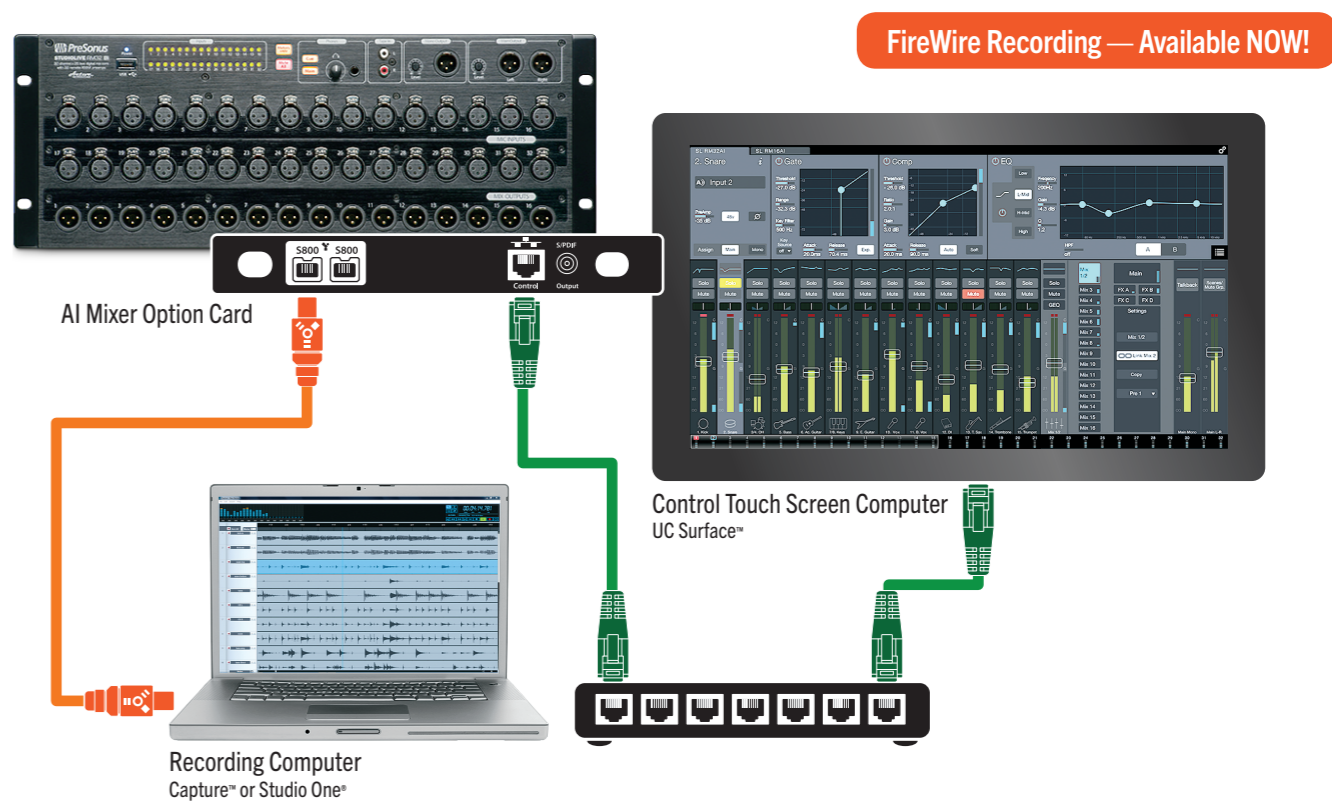

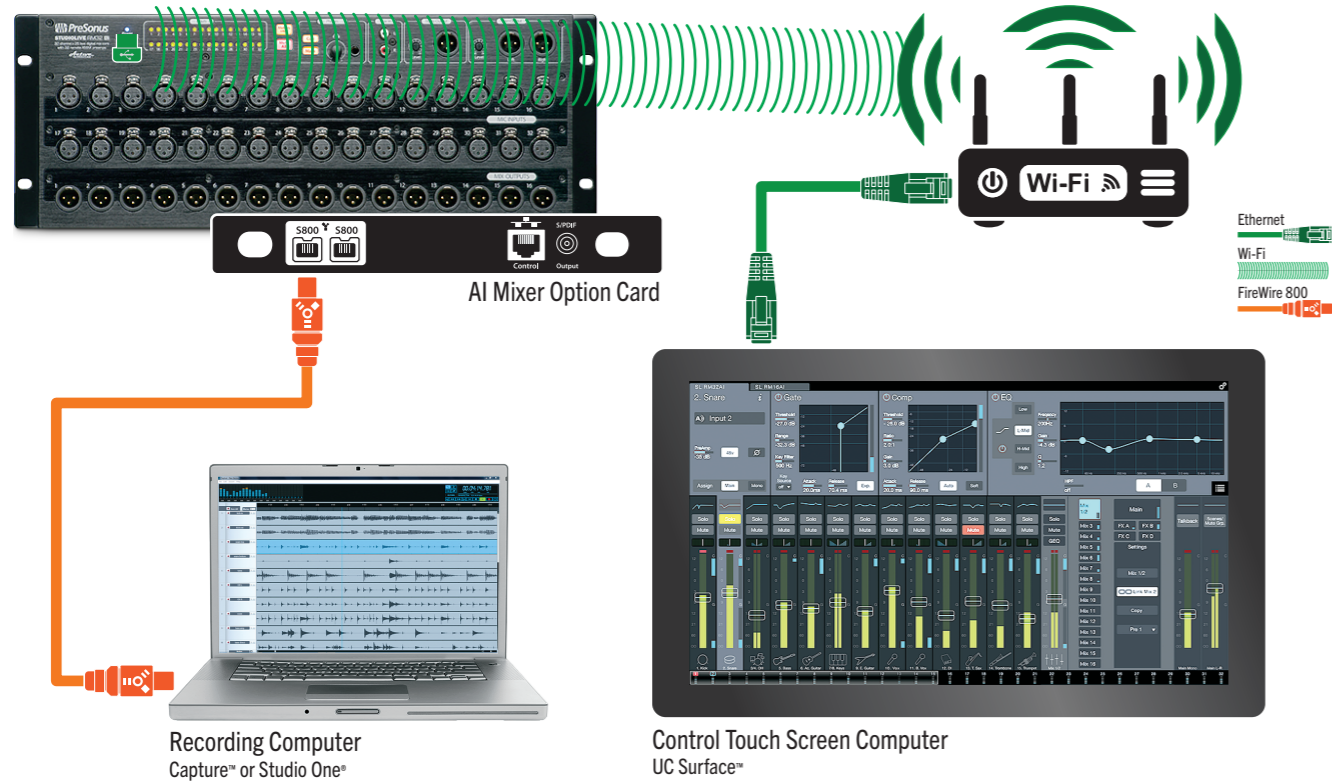

Dante Control & Recording — Coming December 2014

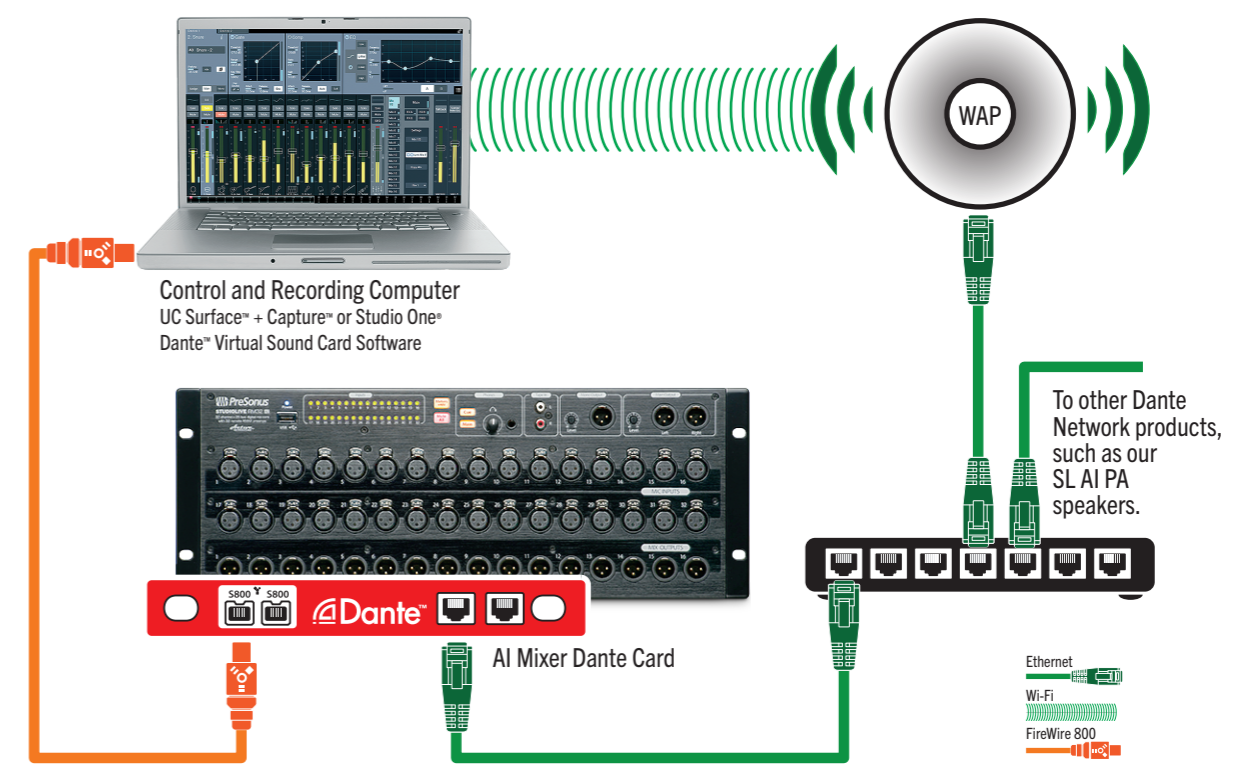

Dante Control and Recording — Coming December 2014

Dante recording can be done using the Dante Virtual Sound Card software and drivers for Mac and PC (included with the purchase of the Dante option card). Visit Audinate for more information on the Dante virtual sound card (<https://www.audinate.com/products/software/dante-virtual-soundcard>).

FireWire recording: The Dante option card will also support

recording via FireWire while simultaneously sending and receiving streams over the network via Dante. In this case the Dante Ethernet connection from the mixer must also be used for control.

UC Surface™ wireless control: While the mixer does not support simultaneous wireless and Dante Ethernet connectivity you can connect a control computer

wirelessly using a wireless access point connected to your network router. Note: in order to use a wireless access point on a Dante network special care must be taken to filter the Dante packets and avoid flooding the wireless network. Please refer to the Audinate “*Configuring ACL filtered VLANs for Multicast Traffic Management*” document.

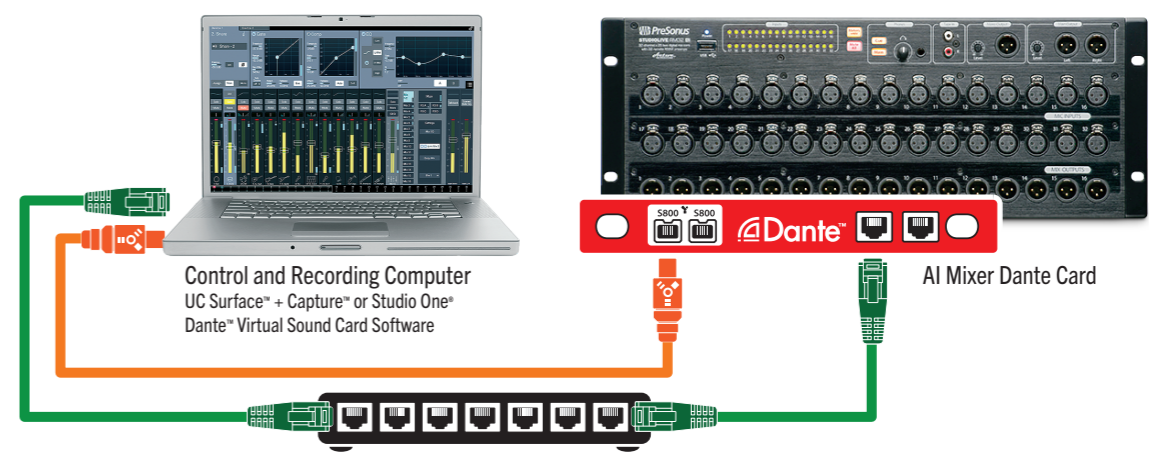

Dante Control & Recording — Coming December 2014

Ethernet Control + FireWire Recording

Wireless Dante™ Touch Screen Computer Control via Wi-Fi

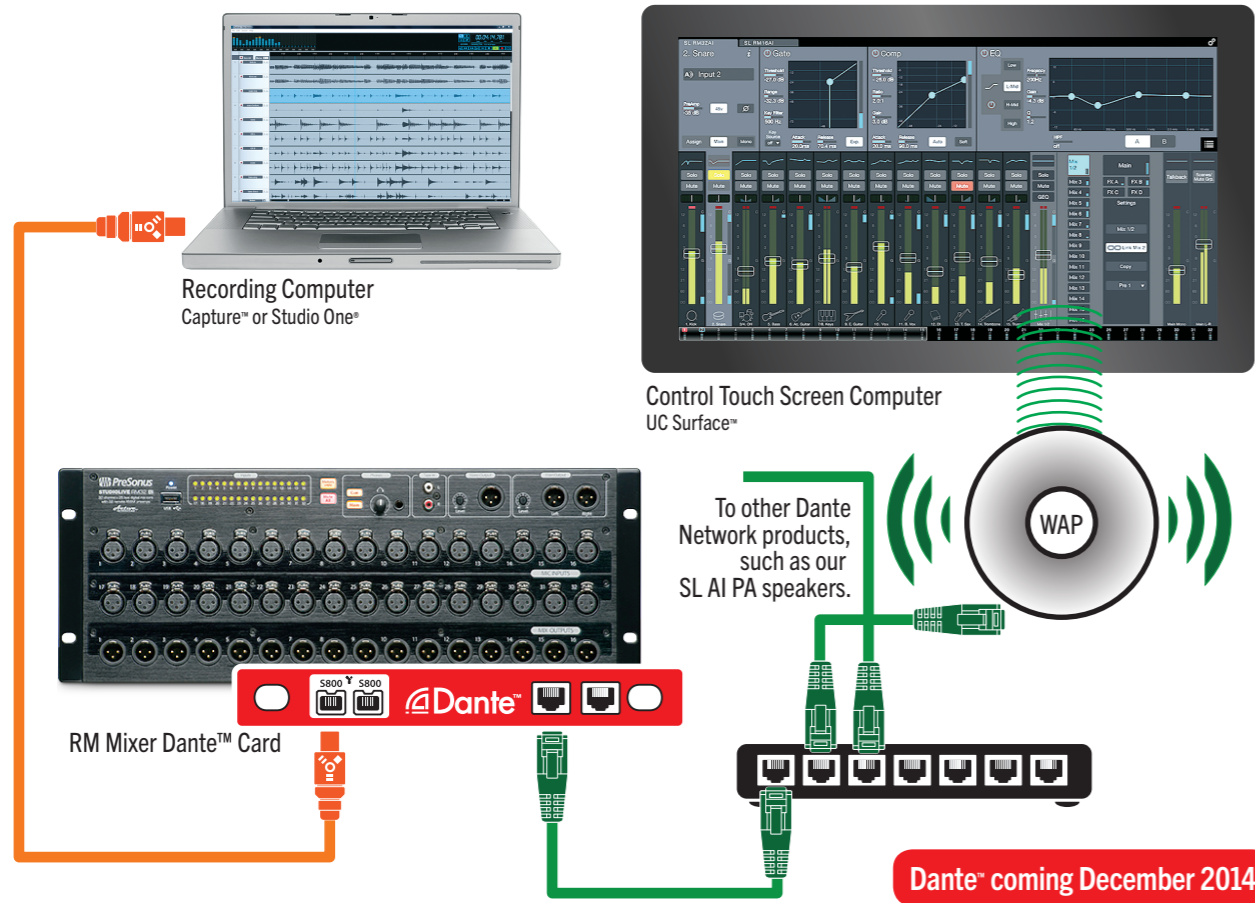

AVB Control and Recording — Coming Q2 2015

AVB recording can be done with a compatible Mac computer using the built-in Core Audio support. Any Mac computer with a Thunderbolt port running OS 10.9 or later is supported. AVB recording to a PC currently requires 3rd party Ethernet cards and drivers.

FireWire recording: The AVB option card will also support recording via FireWire while

simultaneously sending and receiving streams over the network via AVB. In this case the AVB Ethernet connection from the mixer must also be used for control.

UC Surface™ wireless control: While the mixer does not support simultaneous wireless and AVB Ethernet connectivity you can connect a control computer wirelessly using a wireless access

point connected to your network router. Note: because AVB switches are designed to manage the AVB traffic along with standard network traffic there's no need for special configuration to support a wireless access point.

Ethernet Control + AVB Recording

Wired Ethernet AVB Control



Ethernet Control + Dante™ Recording

Wired Ethernet Dante™ Touch Screen Computer Control

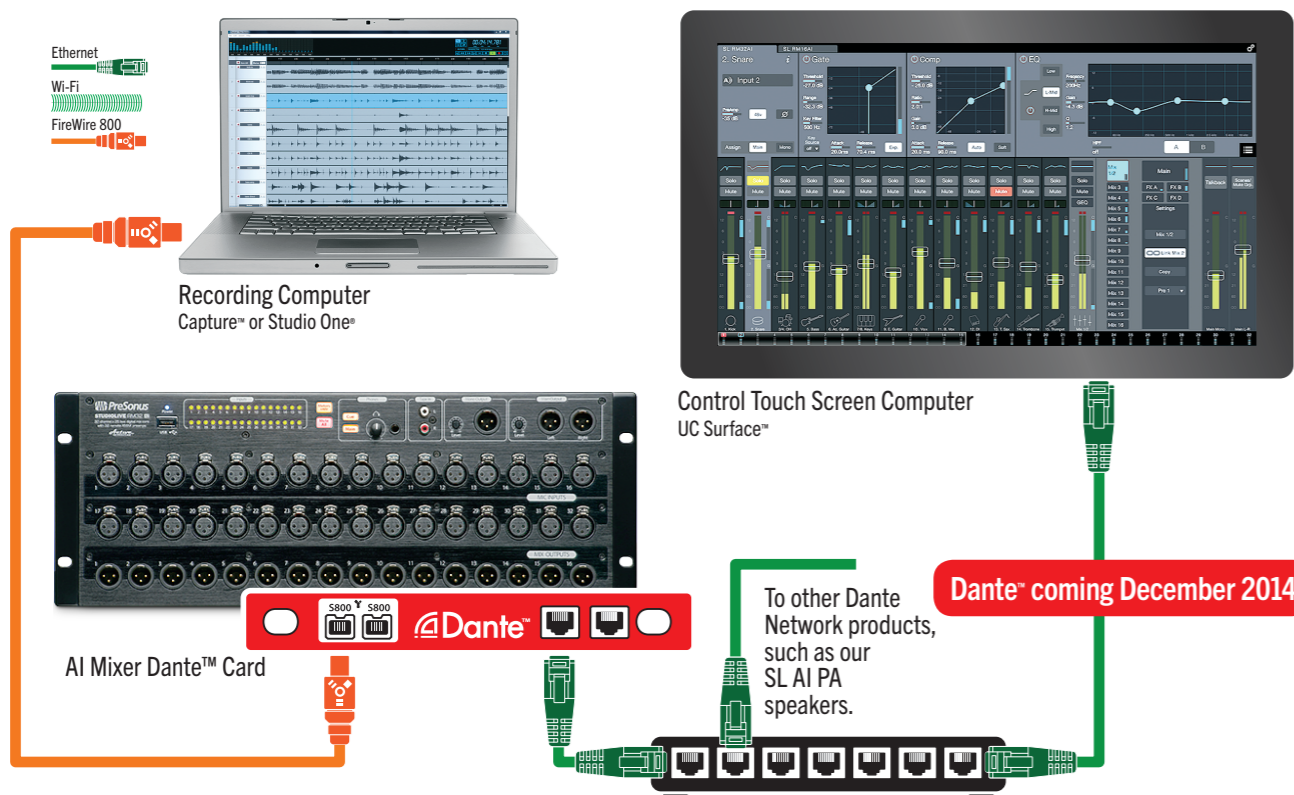

Ethernet Control + FireWire Recording

Wireless AVB Control via Wi-Fi

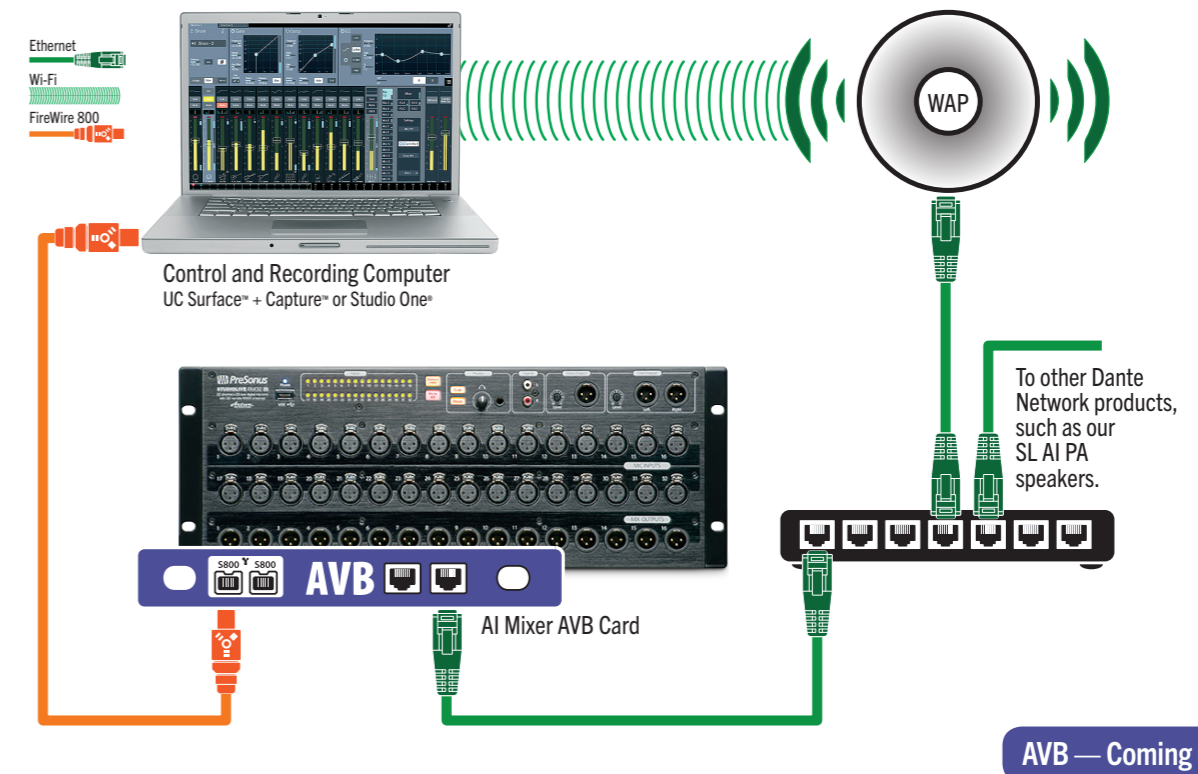

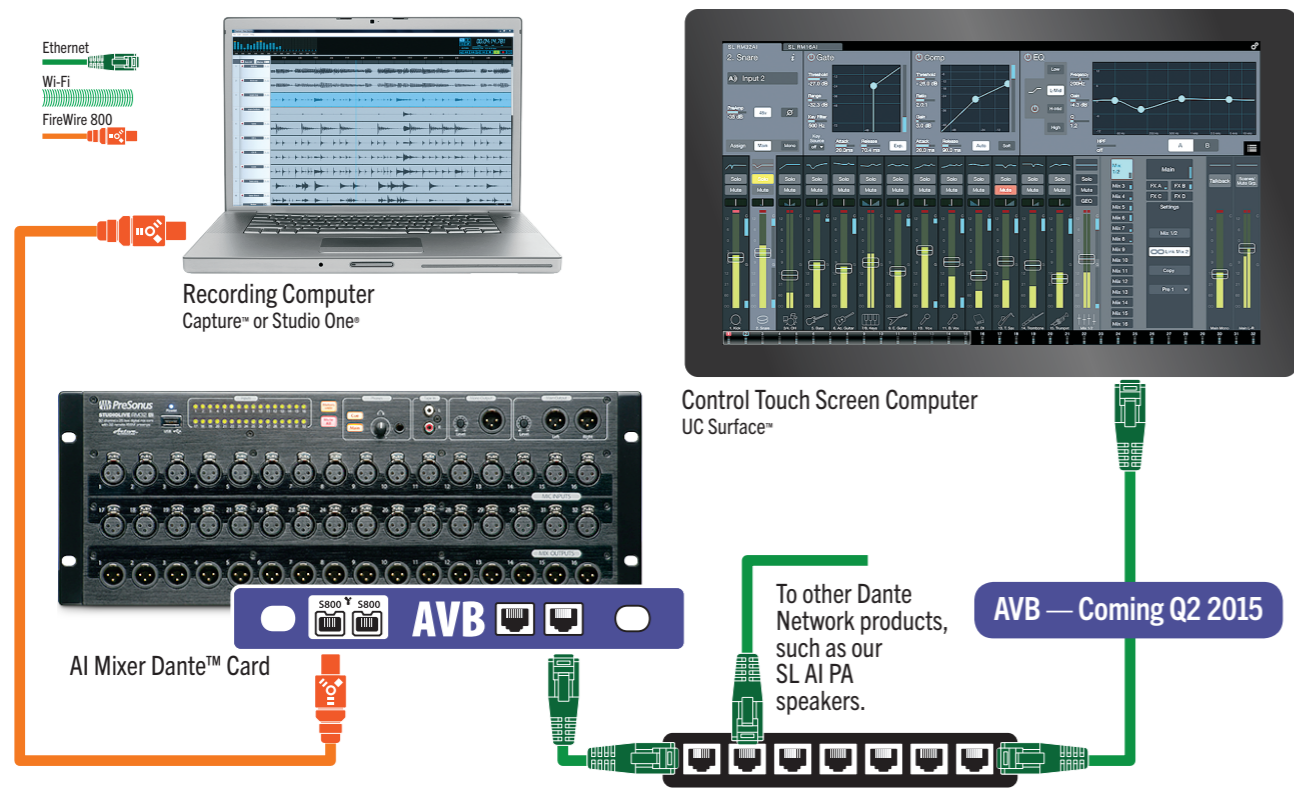
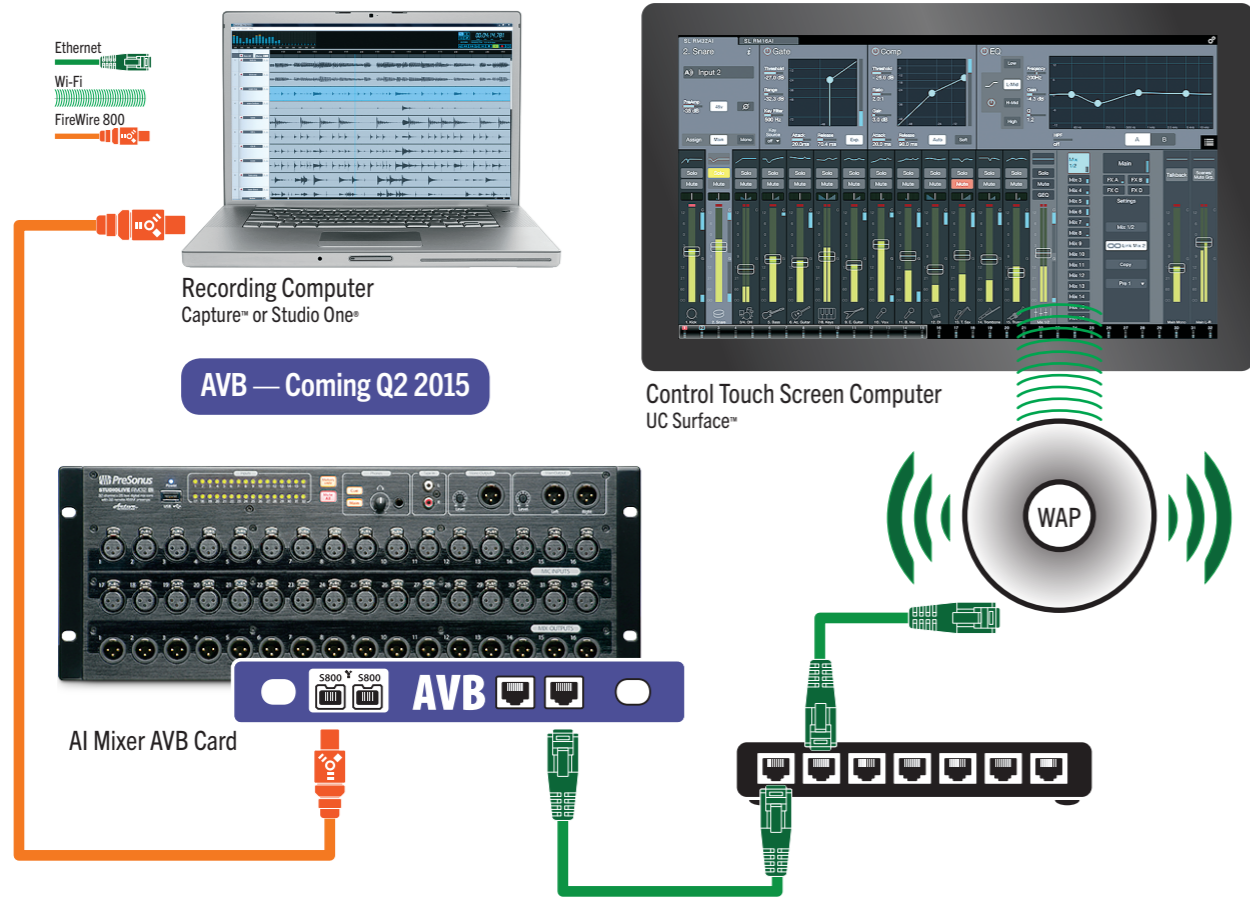

UC Surface control can also be done with one or more iPads using a Wi-Fi router or wireless Wi-Fi dongle. Sixteen iPhones can take advantage of QMix-AI, our advanced

personal monitor mix control system. In most applications, we recommend the use of a Wi-Fi router or access point for best results.

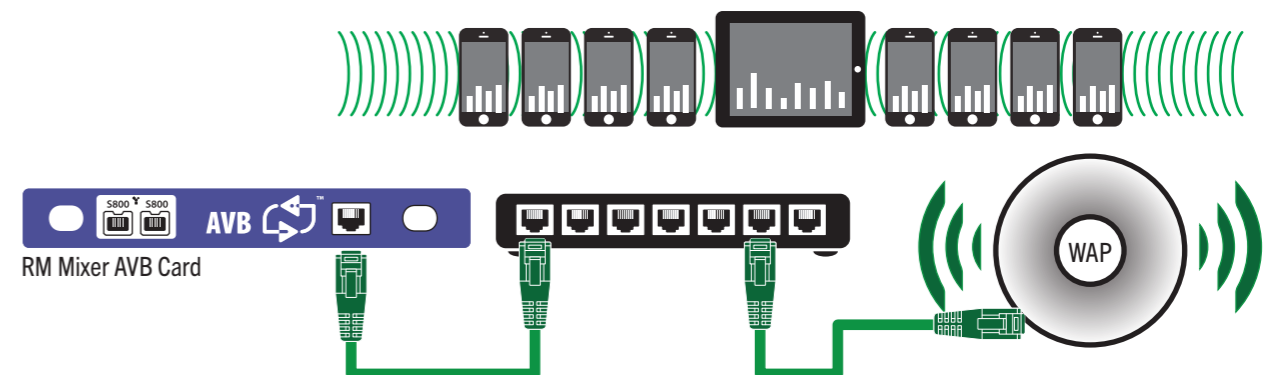
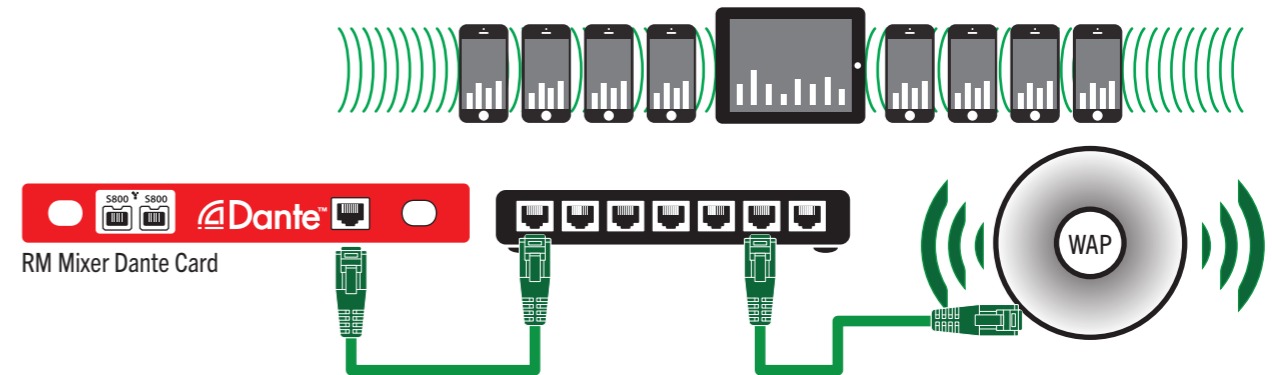
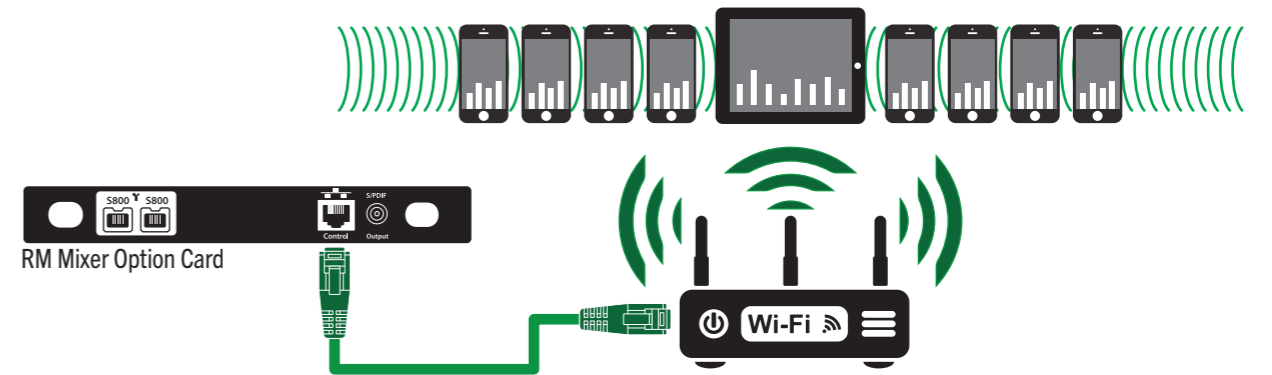

3. Cascaded Mixer Control and Recording

Control for the RM mixers is done via network control only. This can be done with either a wired Ethernet connection or wirelessly with the included USB Wi-Fi dongle.

NOTE: Recording via Ethernet (Dante or AVB) requires a wired Ethernet connection for recording and control (control will not work

with the USB Wi-Fi dongle used simultaneously with a wired Ethernet connection).

Cascading is currently only supported via a FireWire connection between two mixers.

FireWire recording can be done with the FireWire 800, Dante, or AVB option cards.

Note: the FireWire cable length will limit the distance your recording computer can be from the mixer.

Ethernet Control + FireWire Recording

Wired Ethernet Computer Control

CASCADING

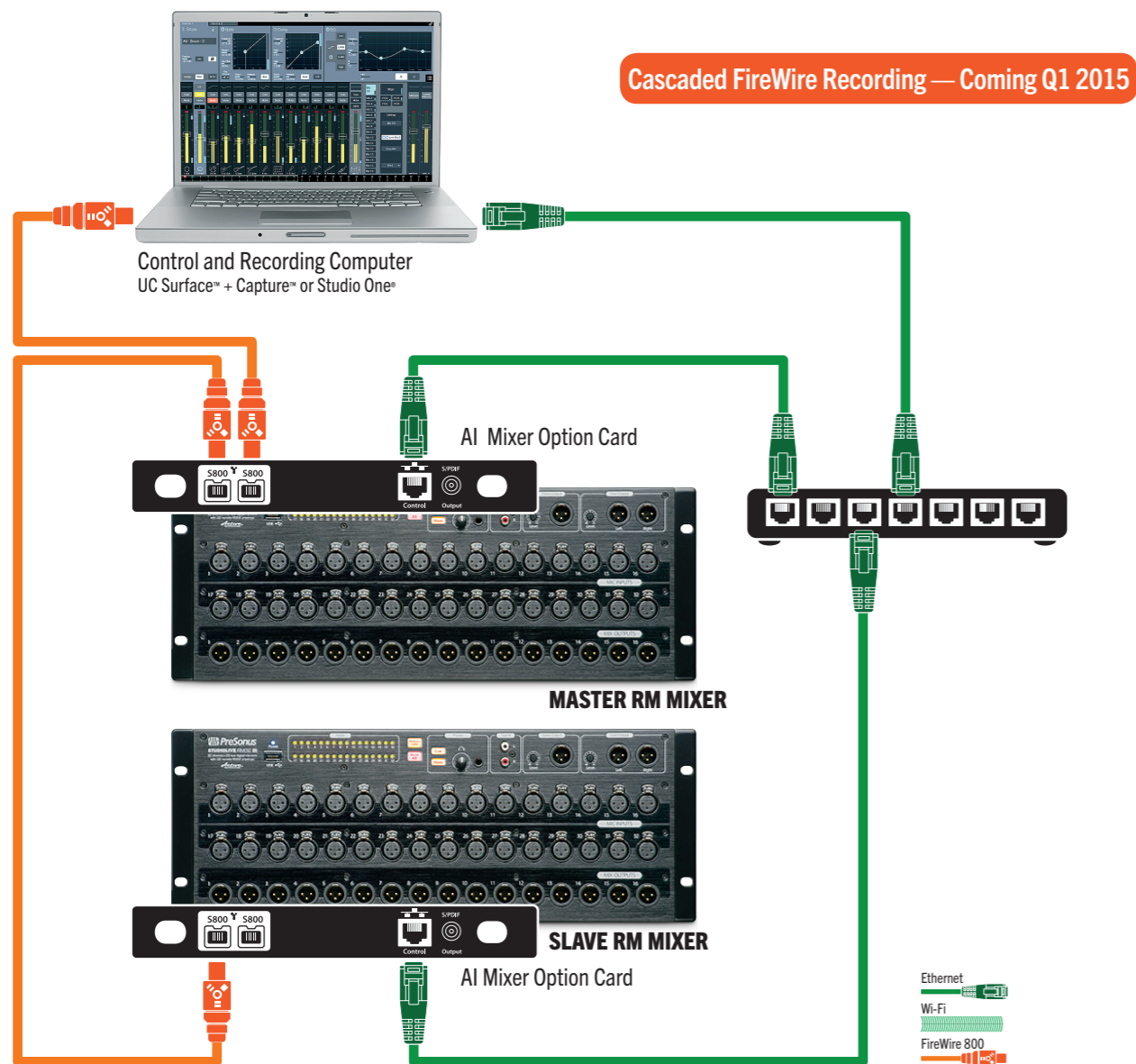

Cascaded FireWire Recording — Coming Q1 2015

Ethernet Control + FireWire Recording

Ethernet Computer Control via Wi-Fi

CASCADING

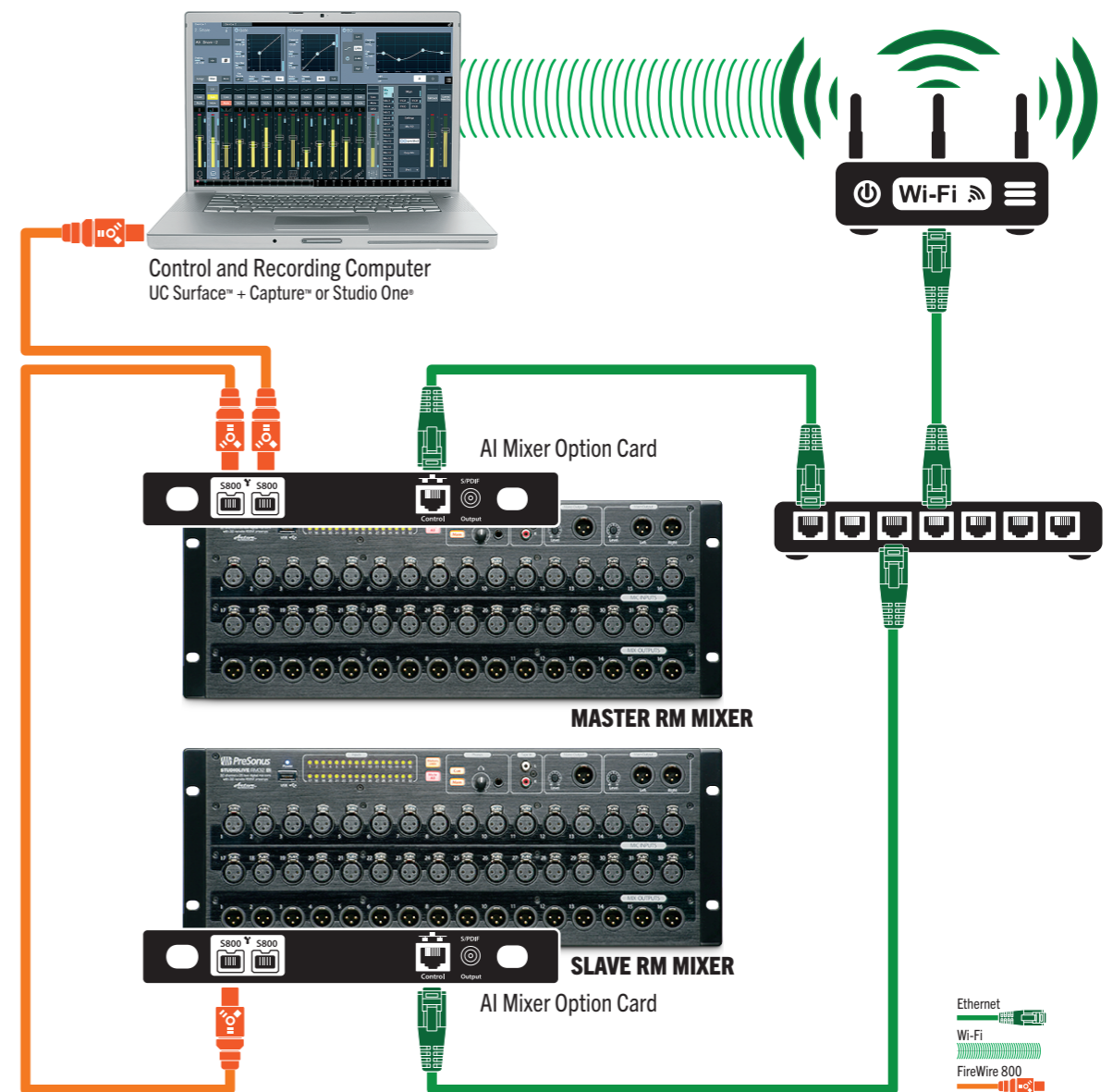

Ethernet Control + FireWire Recording Ethernet Touch Screen Computer Control via Wi-Fi **CASCADING**

Ethernet Control + FireWire Recording Wired Ethernet Touch Screen Computer Control **CASCADING**

Cascaded FireWire Recording — Coming Q1 2015

Cascaded FireWire Recording — Coming Q1 2015

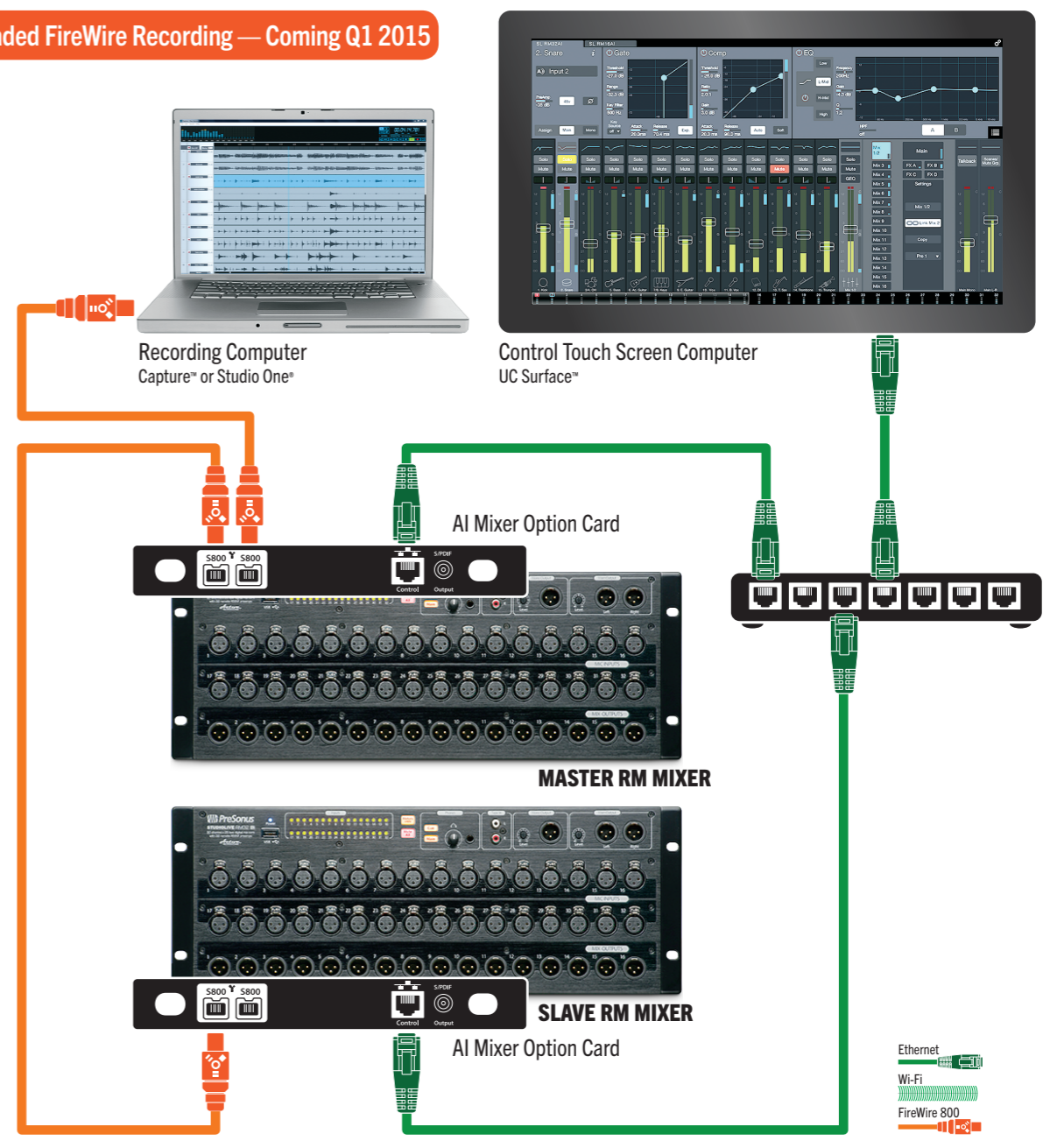
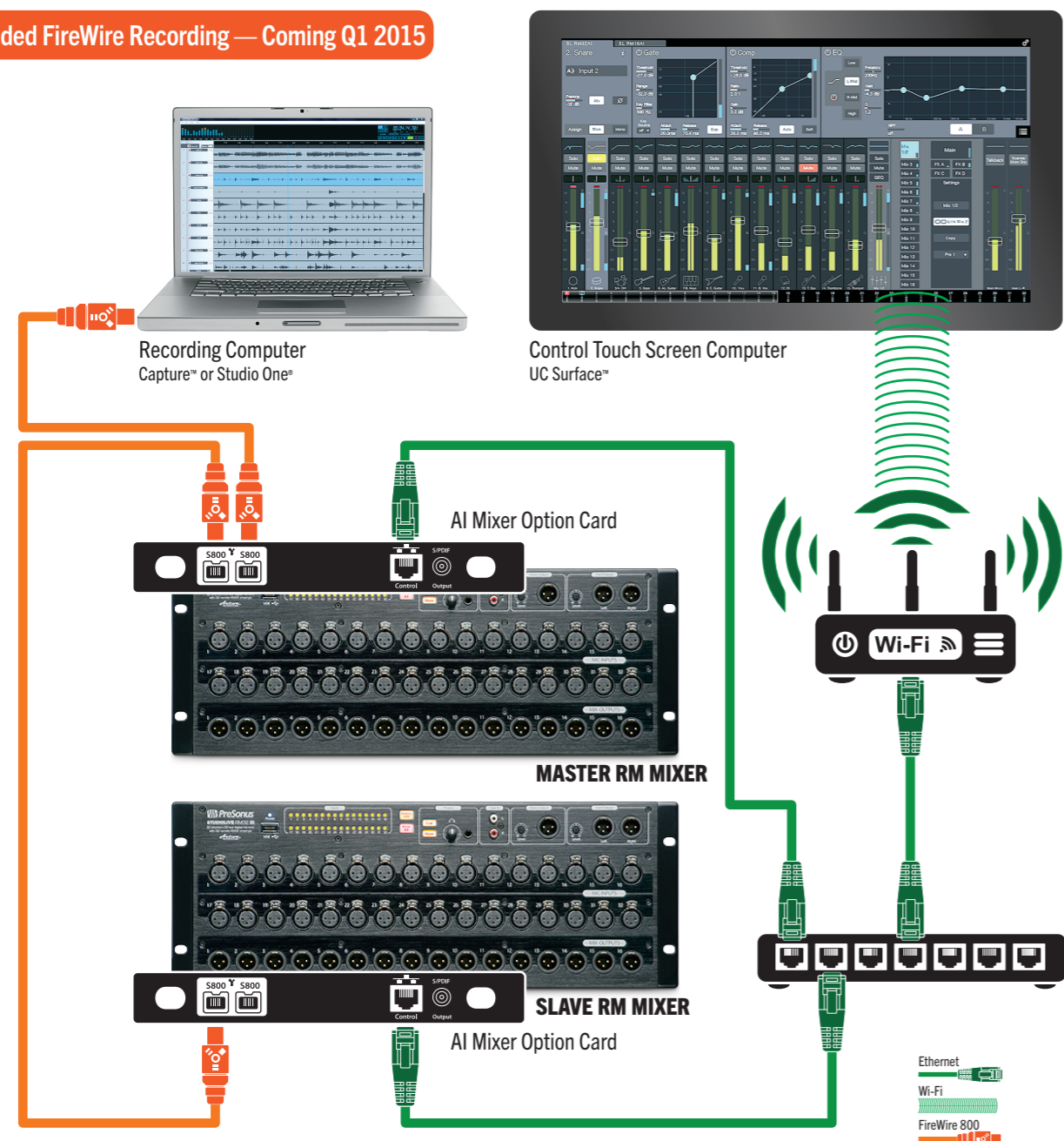

Cascaded Dante™ Recording — Coming Q1 2015

Dante recording can be done using the Dante Virtual Sound Card software and drivers for Mac and PC (included with the purchase of the Dante option card). Visit Audinate for more information on the Dante virtual sound card <https://www.audinate.com/products/software/dante-virtual-soundcard>

Wireless control: While the mixer does not support simultaneous wireless and Dante Ethernet connectivity you can connect a control computer wirelessly using a wireless access point connected to your network router. Note: in order to use a wireless access point on a

Dante network special care must be taken to filter the Dante packets and avoid flooding the wireless network. Please refer to the Audinate “Configuring ACL filtered VLANs for Multicast Traffic Management” document.



Ethernet Control + **Dante™** Recording **Wired Ethernet Computer Control** **CASCADING**

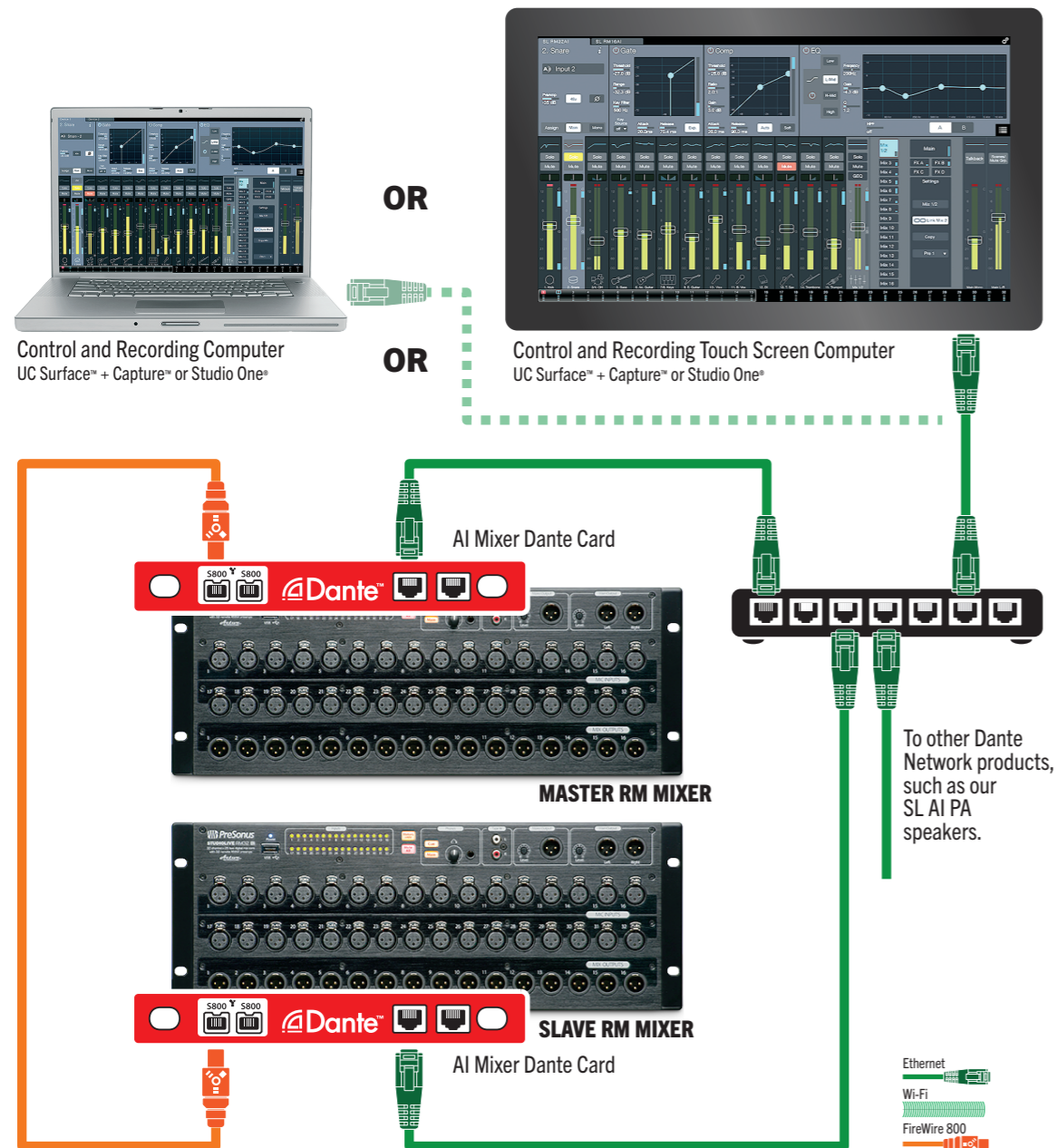

Cascaded Dante™ Recording — Coming Q1 2015

Ethernet Control + FireWire Recording **Ethernet Computer Control via Wi-Fi** **CASCADING**

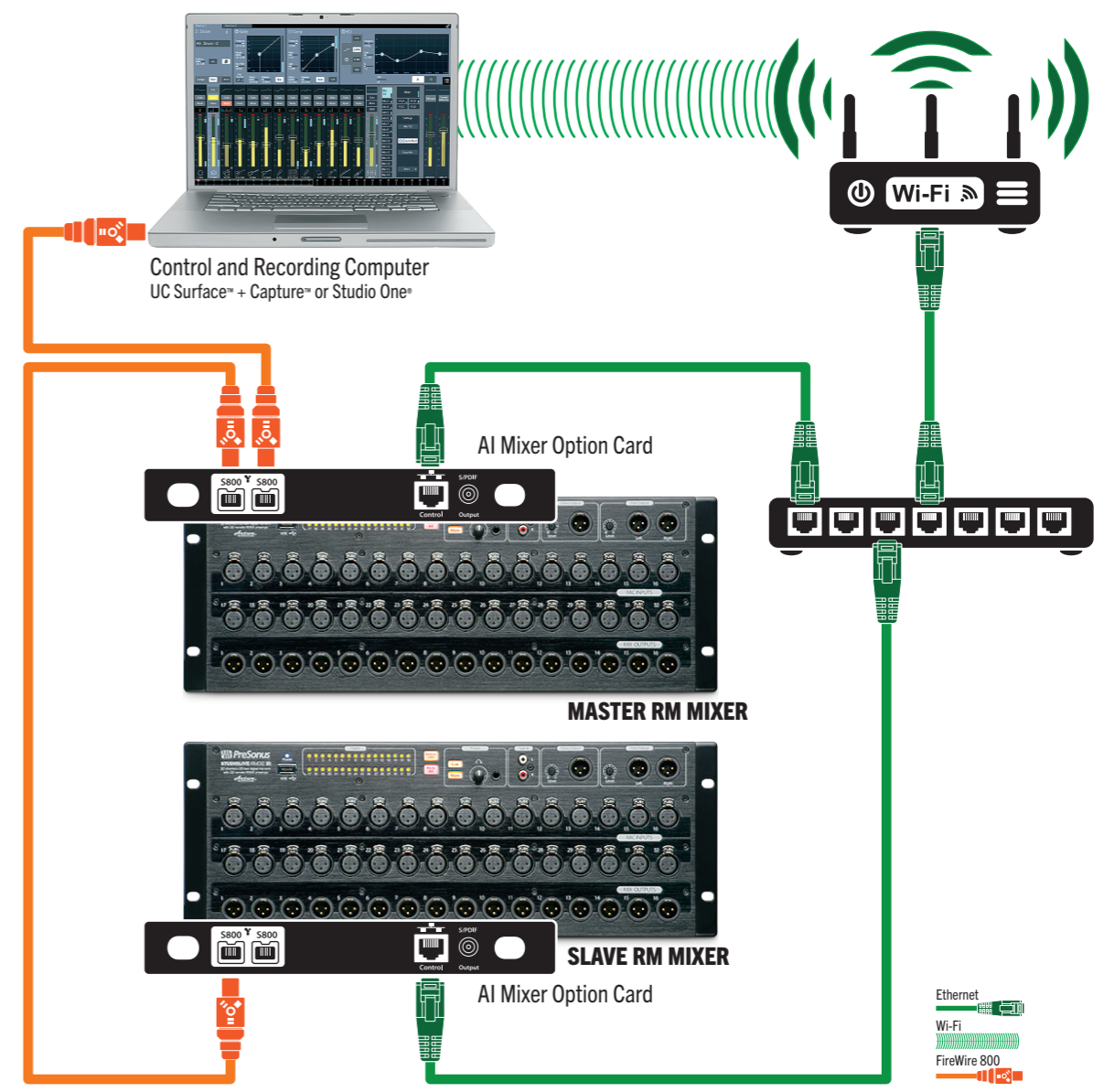



Cascaded Dante® Recording — Coming Q1 2015

Ethernet Control + FireWire Recording | Ethernet Computer Control via Wi-Fi | **CASCADING**

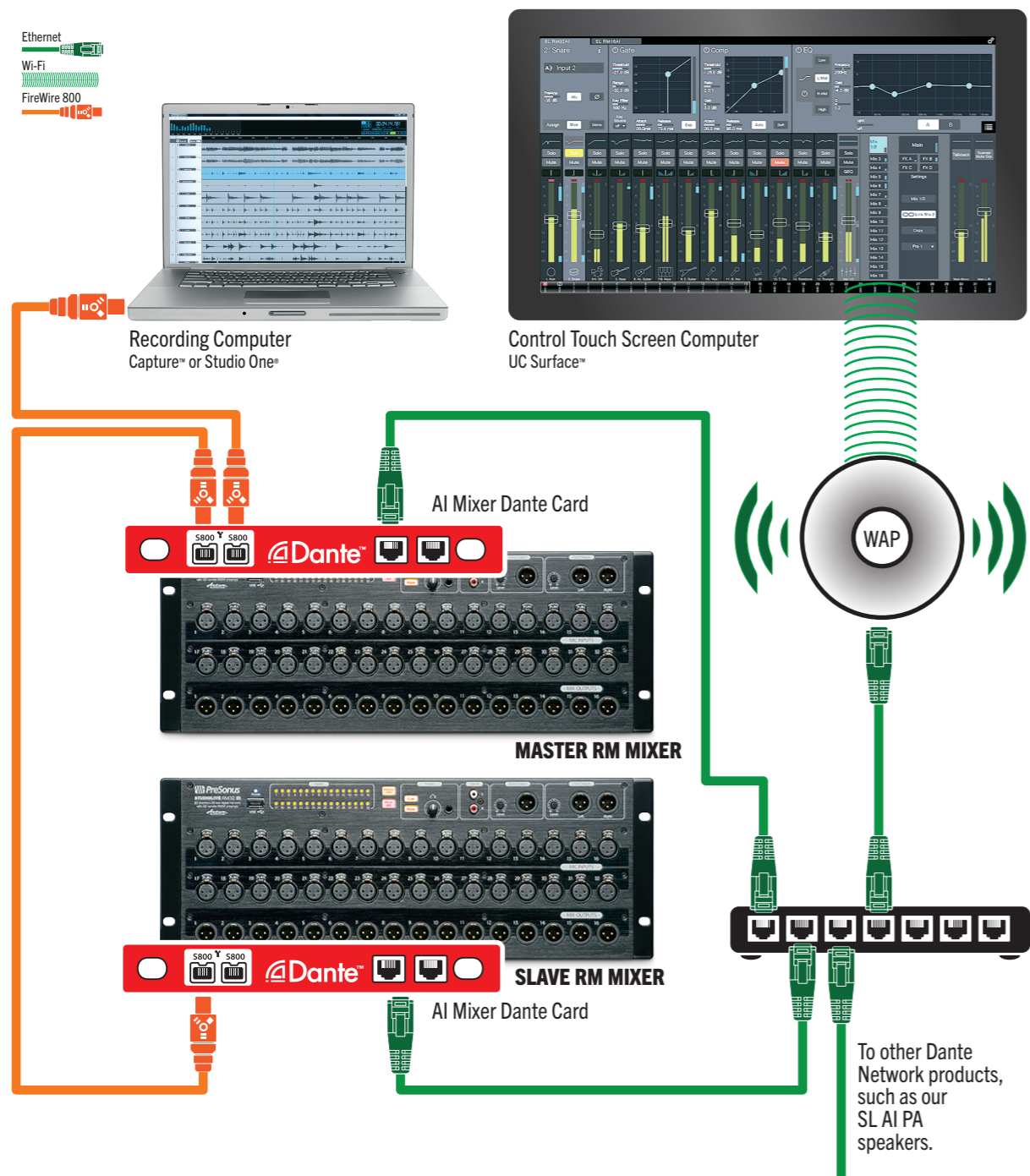

AVB Recording — Coming Q2 2015

AVB recording can be done with a compatible Mac computer using the built-in Core Audio support. Any Mac computer with a Thunderbolt port running OS 10.9 or later is supported. AVB recording to a PC currently requires 3rd party Ethernet cards and drivers.

Wireless control: While the mixer does not support simultaneous wireless and AVB Ethernet connectivity you can connect a control computer wirelessly using a wireless access point connected to your network switch. Note: because AVB switches are designed to

AVB

manage the AVB traffic along with standard network traffic there's no need for special configuration to support a wireless access point.

Ethernet Control + AVB Recording | Wired Ethernet Computer Control | **CASCADING**

Cascaded AVB Recording — Coming Q2 2015

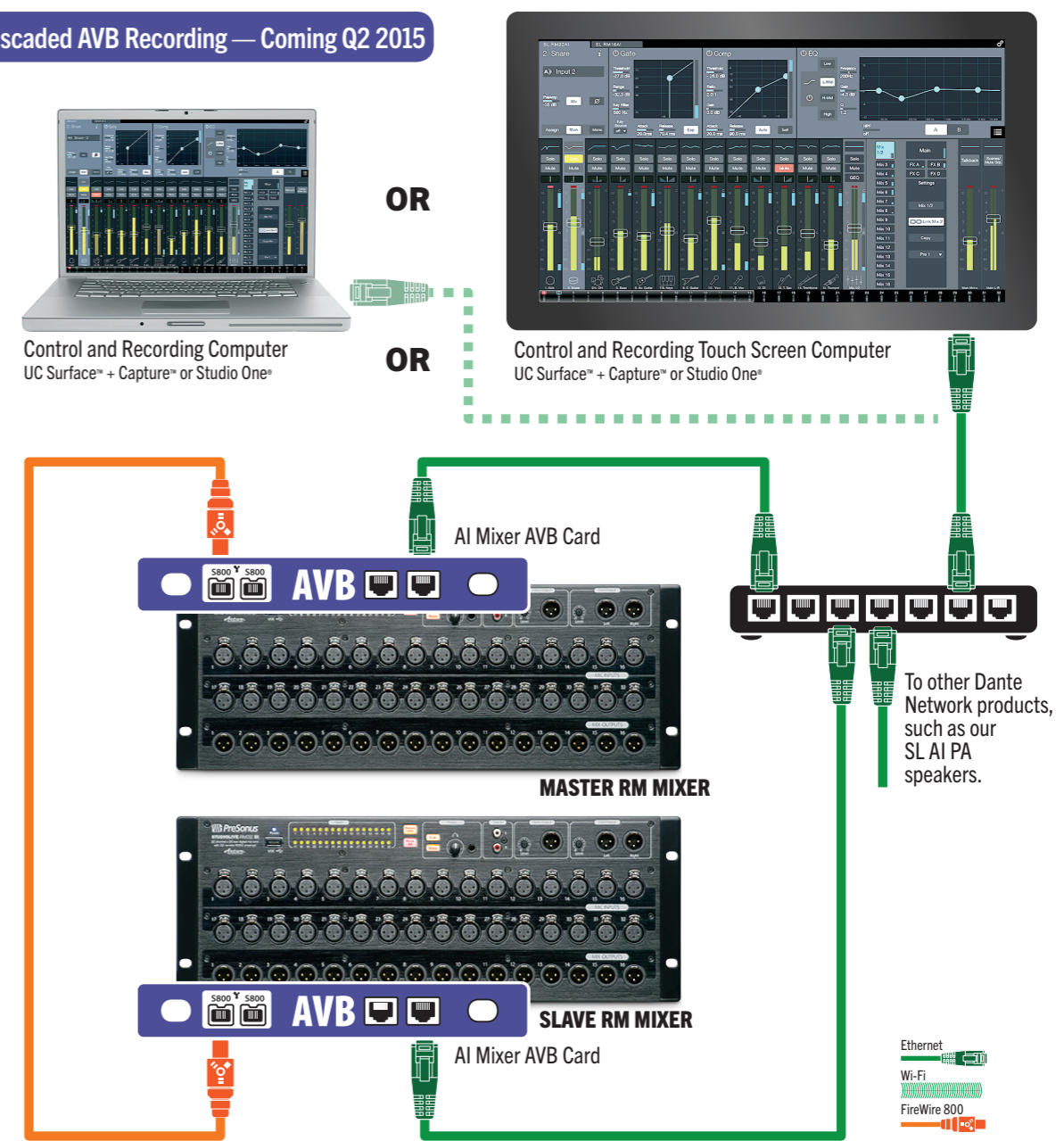

Cascaded AVB Recording — Coming Q2 2015

Cascaded AVB Recording — Coming Q2 2015

Ethernet Control + FireWire Recording Ethernet Computer Control via Wi-Fi **CASCADING**

Ethernet Control + FireWire Recording Wired Ethernet Computer Control **CASCADING**

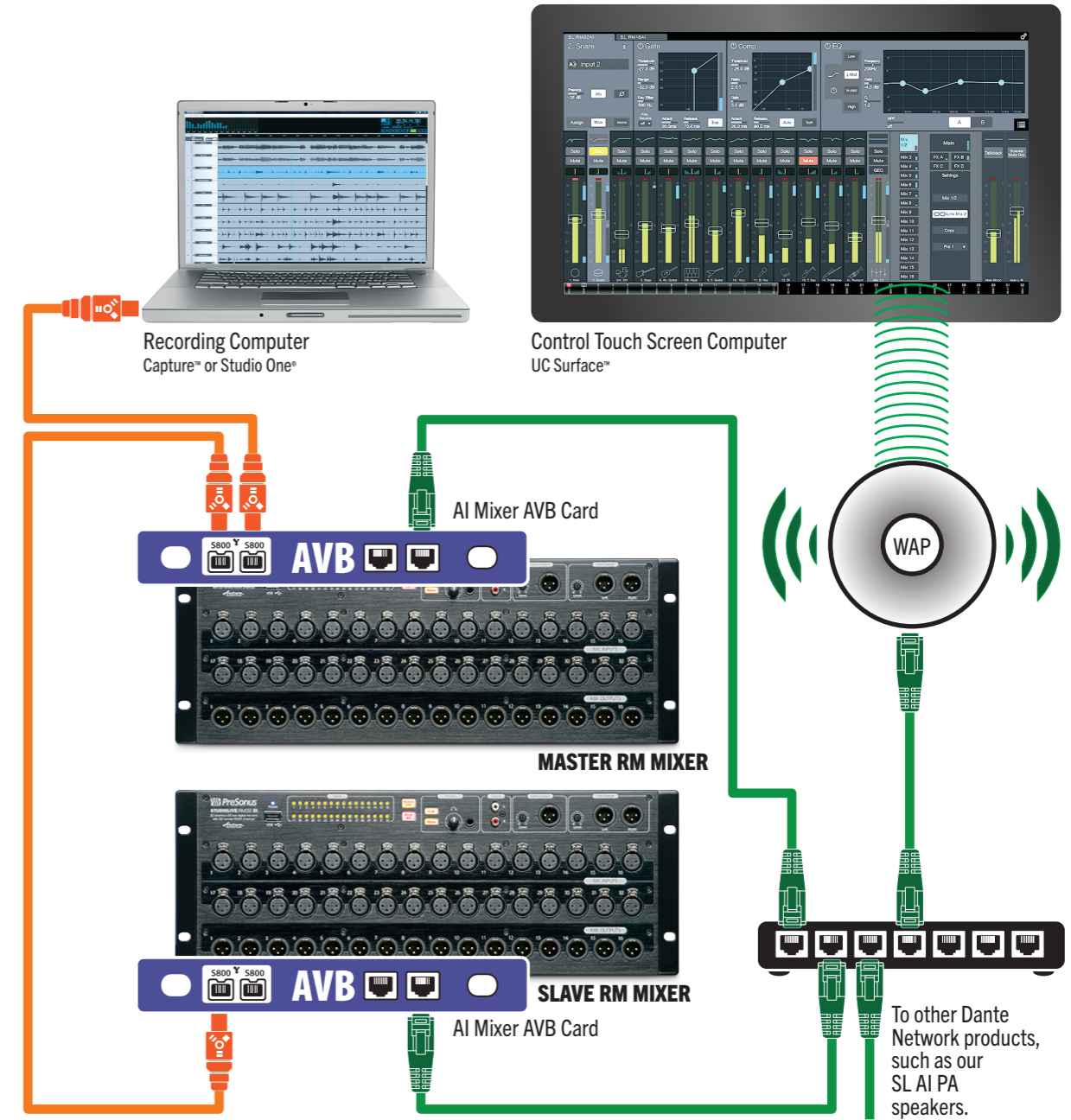
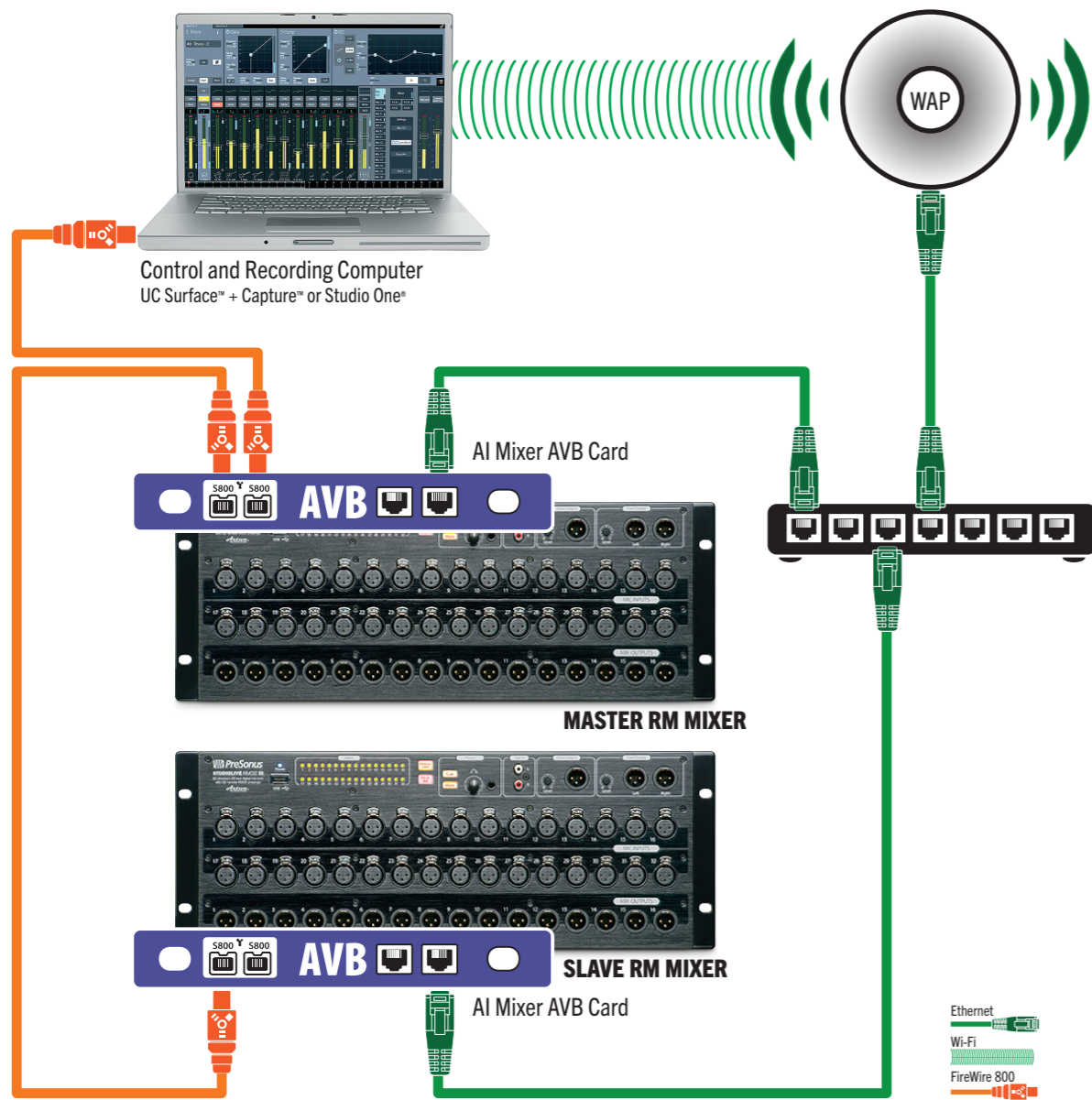

4. Remote Stage Box / Mixer Control and Record — Coming in 2015

Any StudioLive AI family mixer can be used as a remote stage IO, including the RM series rack mixers. Since the RM series is a complete mixer in a stage box form factor it can be used both as remote IO and a complete monitor mixer.

Control for the RM mixers is done via network control only. This can be done with either a wired Ethernet connection or wirelessly with the included USB Wi-Fi dongle.

NOTE: Recording via Ethernet (Dante or AVB) requires a wired Ethernet connection for recording and control (control will not work with the USB Wi-Fi dongle used simultaneously with a wired Ethernet connection).

Gain sharing — coming Q1 2015

StudioLive AI mixers will support automatic gain compensation to manage gain sharing with shared inputs on a Dante or AVB network. When gain compensation is activated on an input, any change to the preamp gain on that input will also

apply digital trim to compensate for the gain change resulting in consistent gain staging for all listeners on the network.

Since the compensation happens at the input of all StudioLive AI mixers (including RM rack mixer), it's not necessary for other mixers on the network to compensate for changes in the preamp gain.

This means that any mixer or device from any manufacture on the network will benefit from PreSonus StudioLive gain compensation.

Remote Dante stage box — coming December 2014

StudioLive AI mixers can be networked together using the Dante option card. When connected on a Dante network the mixers can be used to share inputs and mixes to deliver remote IO workflows.

Dante recording can be done using the Dante Virtual Sound Card software and drivers for Mac and PC (included with the purchase of the Dante option card). Visit Audinate for

more information on the Dante virtual sound card <https://www.audinate.com/products/software/dante-virtual-soundcard>

Wireless control: While the mixer does not support simultaneous wireless and Dante Ethernet connectivity you can connect a control computer wirelessly using a wireless access point connected to your network switch. Note: in order to use a wireless access point on a Dante network special care must be taken to filter the Dante packets and avoid flooding the wireless network. Please refer to the Audinate "Configuring ACL filtered VLANs for Multicast Traffic Management" document.



Dante® Remote Stage Box — Coming December 2014

Wired Ethernet Control + FireWire Recording

Dante Audio Transport

STAGE BOX

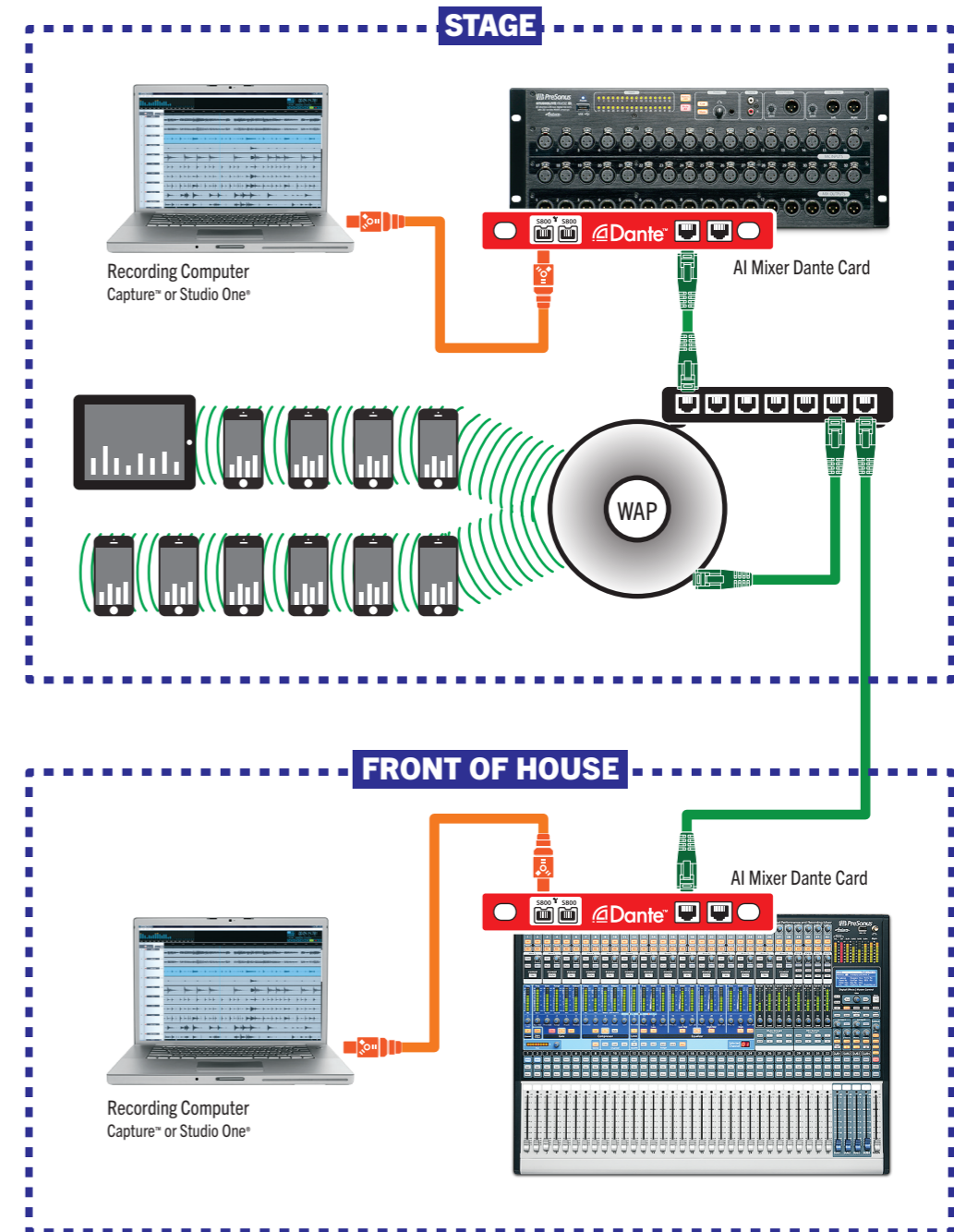

Dante® Remote Stage Box — Coming December 2014

Wired Ethernet Control + Dante and / or FireWire Recording Dante Audio Transport STAGE BOX

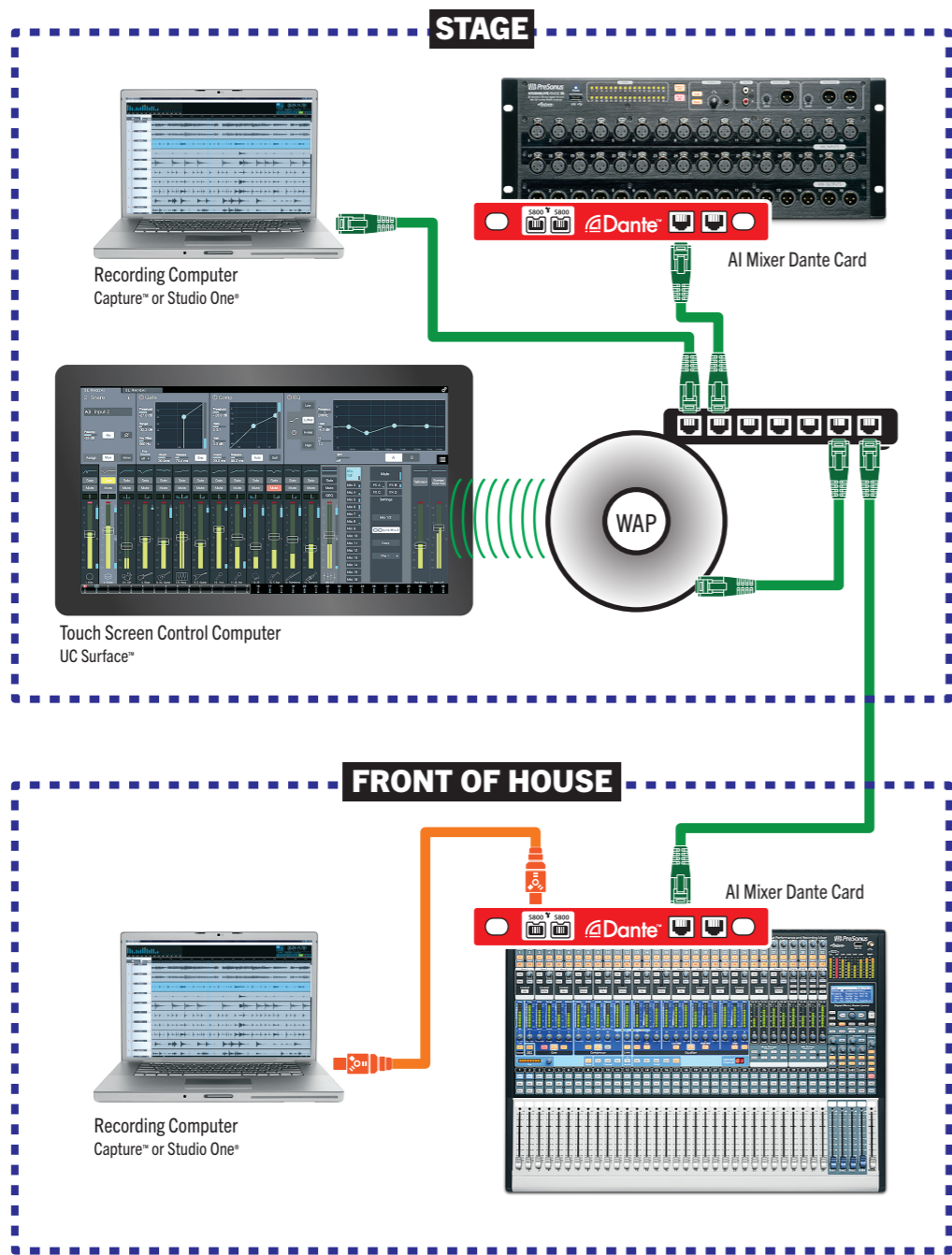

Ethernet
Wi-Fi
FireWire 800

Wired Ethernet Control + Dante Recording Dante Audio Transport CASCADING STAGE BOX

Dante® Remote Stage Box with RM Cascading — Coming Q1 2015

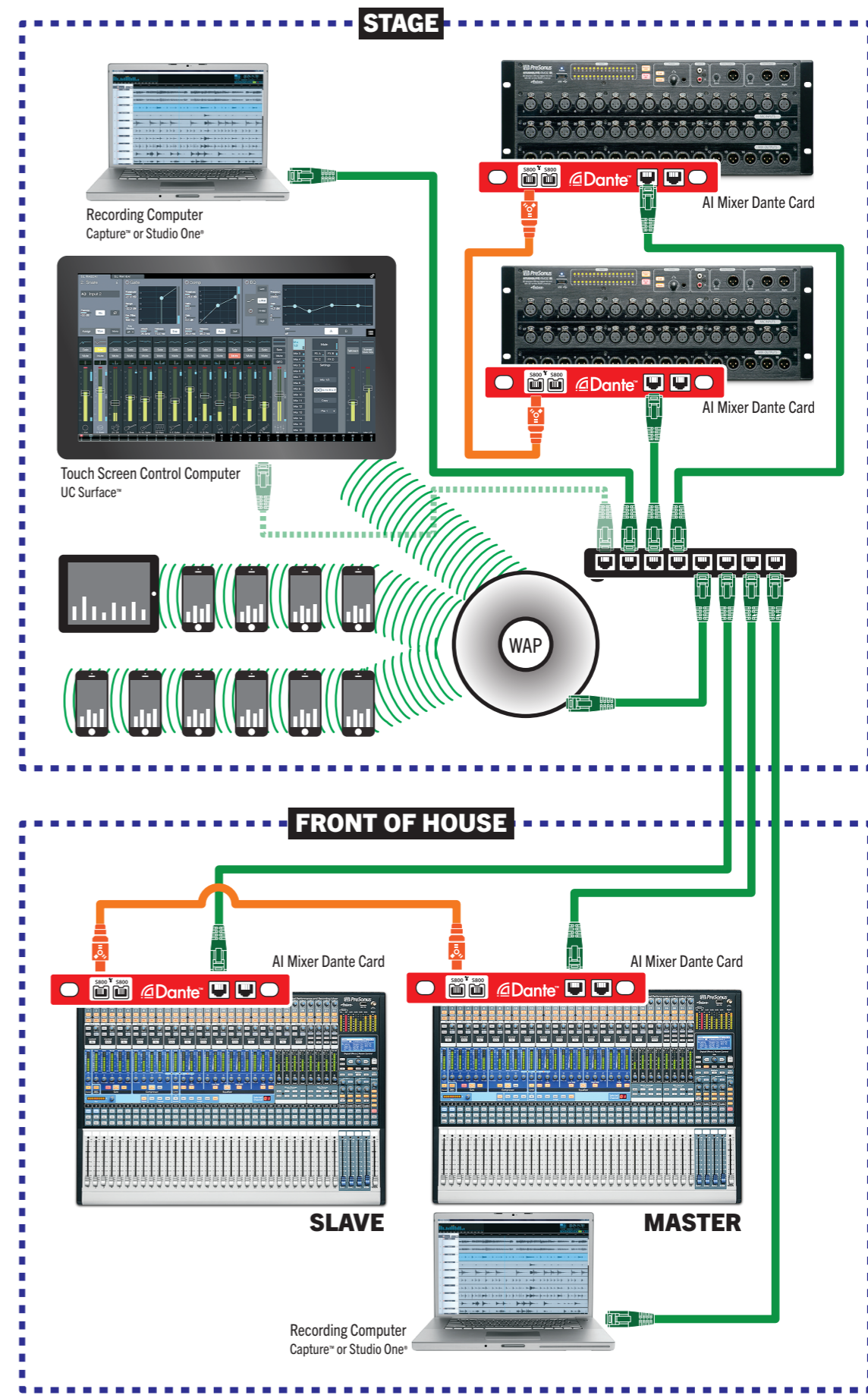

Ethernet
Wi-Fi
FireWire 800

Remote AVB Stage Box — Coming Q2 2015

StudioLive AI mixers can be networked together using the AVB option card. When connected on an AVB network the mixers can be used to share inputs and mixes to deliver remote IO workflows.

AVB recording can be done with a compatible Mac computer using the built-in Core Audio support. Any Mac

computer with a Thunderbolt port running OS 10.9 or later is supported. AVB recording to a PC currently requires 3rd party Ethernet cards and drivers.

Wireless control: While the mixer does not support simultaneous wireless and AVB Ethernet connectivity you can connect a

control computer wirelessly using a wireless access point connected to your network switch. Note: because AVB switches are designed to manage the AVB traffic along with standard network traffic there's no need for special configuration to support a wireless access point.

RM Series Applications

PreSonus

Remote AVB Stage Box — Coming Q2 2015

Wired Ethernet Control + AVB and / or FireWire Recording

AVB Audio Transport

STAGE BOX

Wired Ethernet Control + FireWire Recording

AVB Audio Transport

STAGE BOX

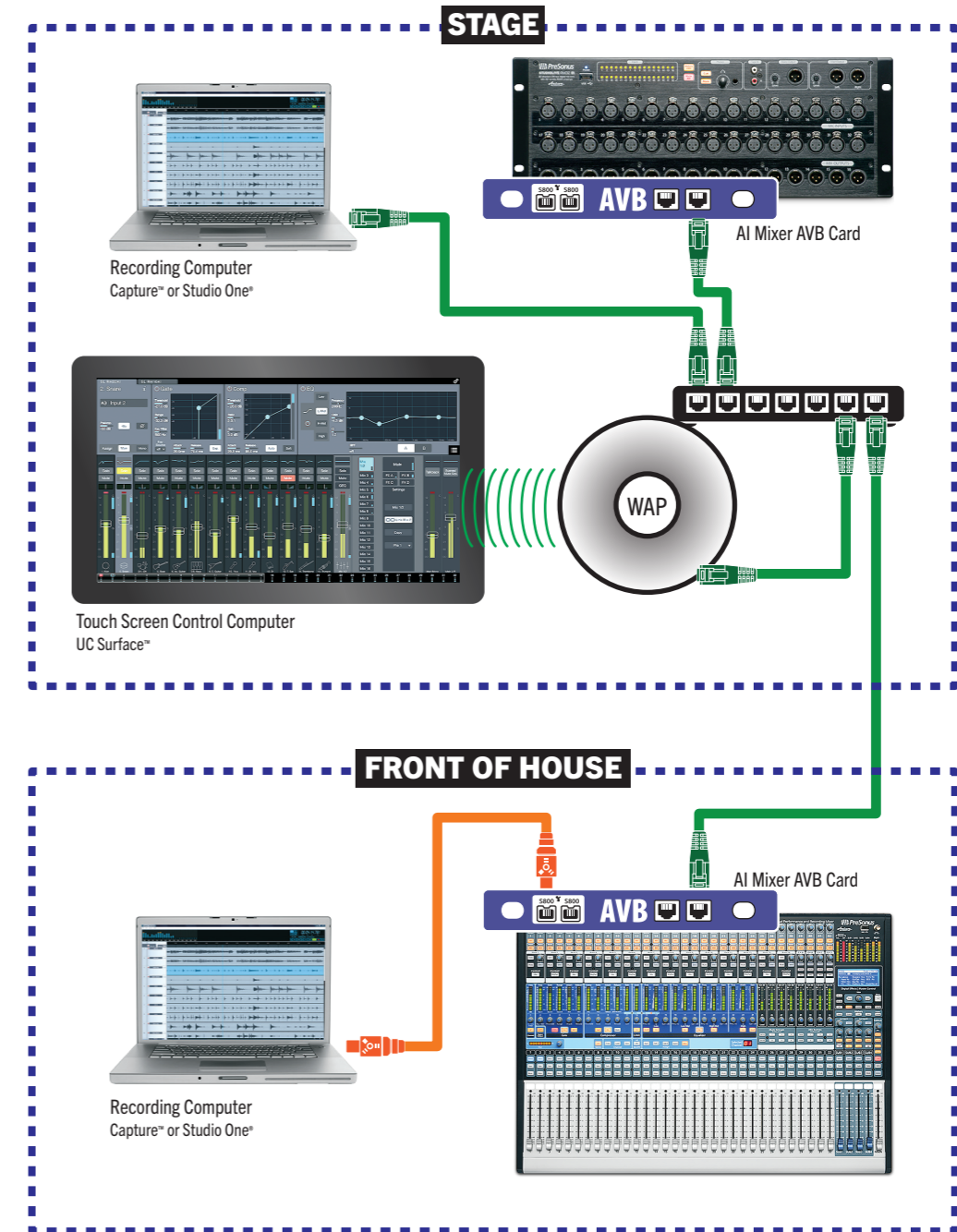
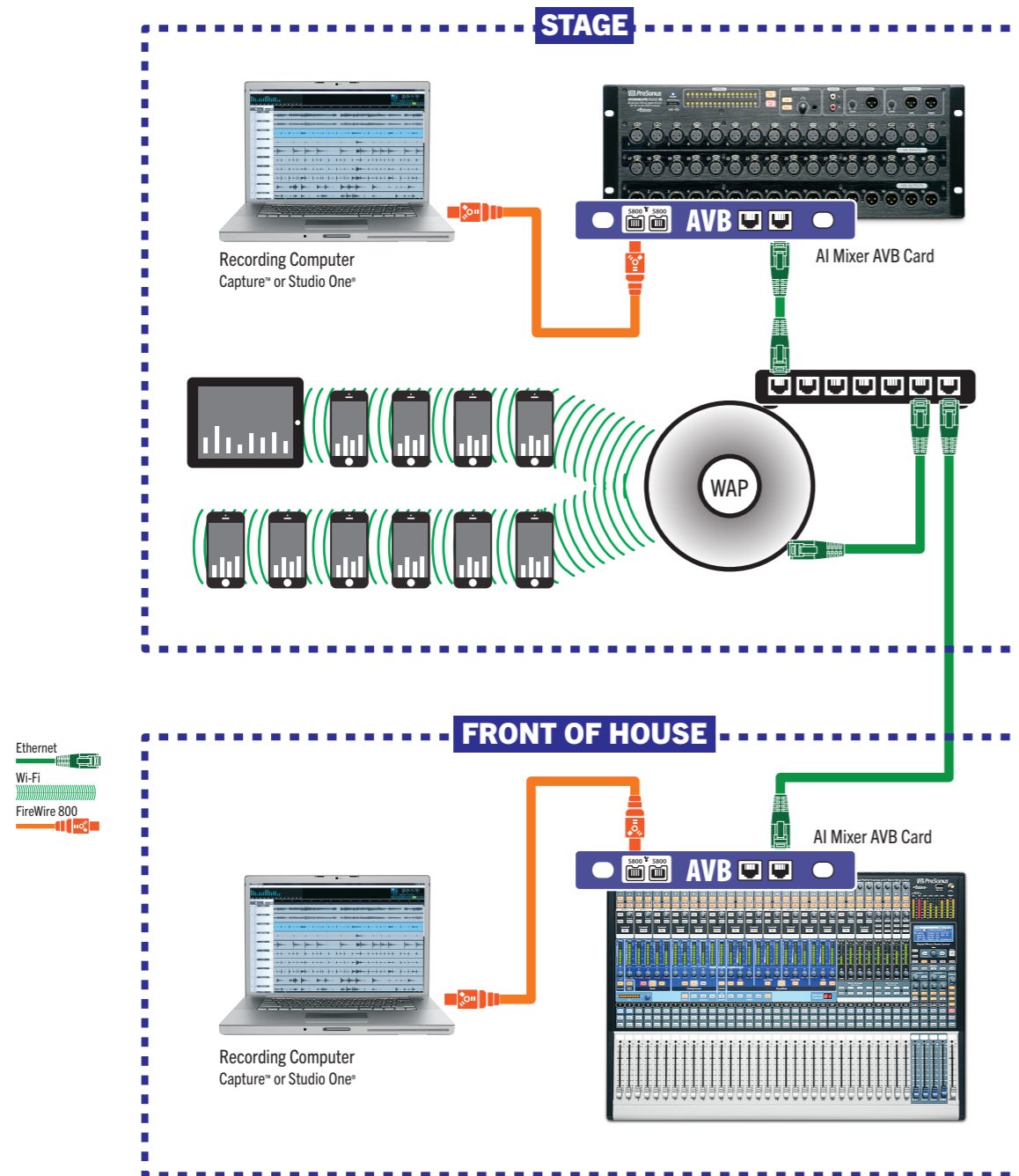

Remote AVB Stage Box — Coming Q2 2015

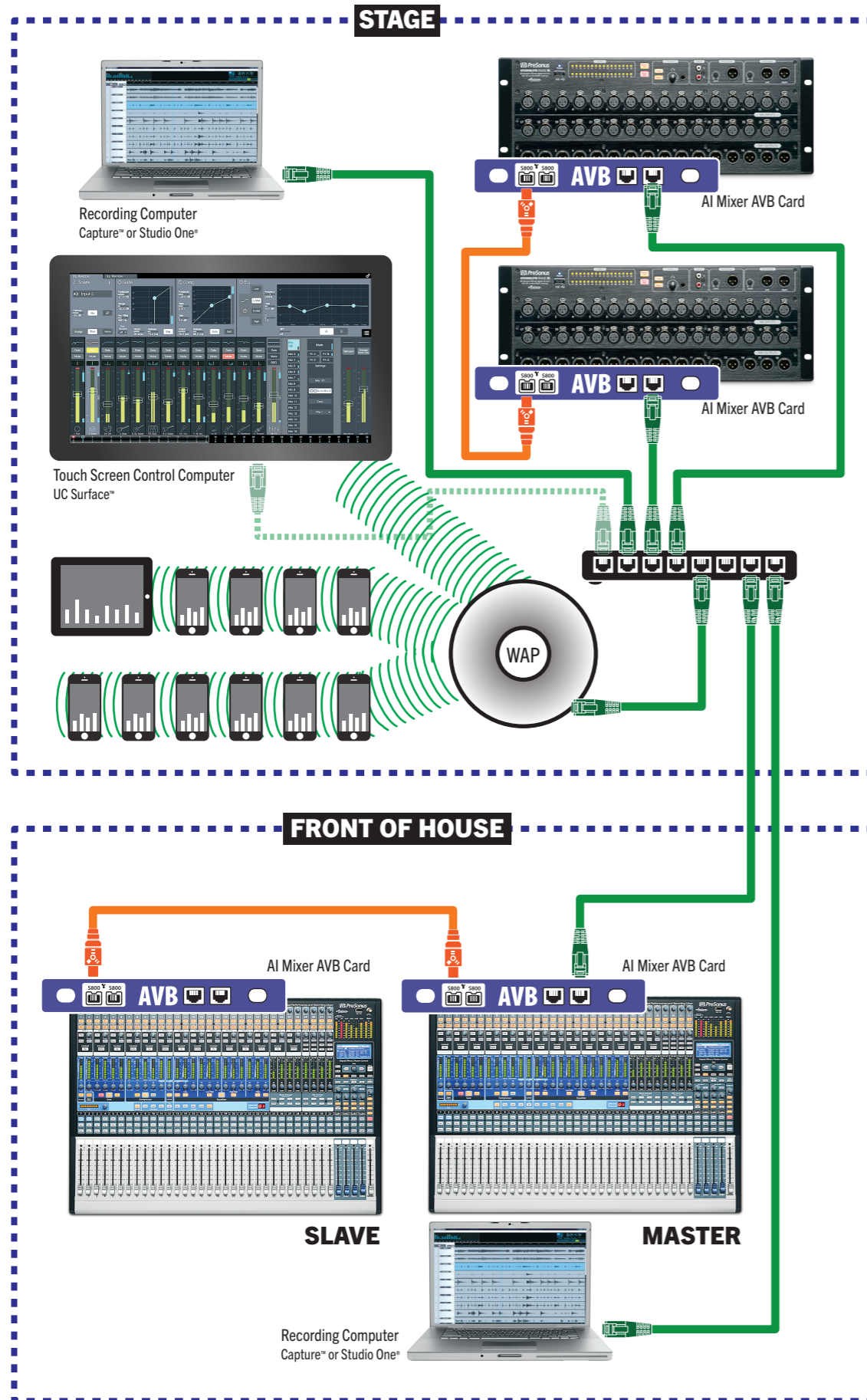

5. Multiple Autonomous Networked Mix Systems — Coming Q1 2015

Control for the RM mixers is done via network control only. This can be done with either a wired Ethernet connection or wirelessly with the included USB Wi-Fi dongle.

NOTE: Recording via Ethernet (Dante or AVB) requires a wired Ethernet connection for recording and control (control will not work with the USB Wi-Fi dongle used simultaneously with a wired Ethernet connection).

Cascading is currently only supported via a FireWire connection between two mixers.

Multiple AI Console & RM Dante Networked Mix Systems — Coming December 2014

Dante recording can be done using the Dante Virtual Sound Card software and drivers for Mac and PC

(included with the purchase of the Dante option card). Visit Audinate for more information on the Dante virtual sound card <https://www.audinate.com/products/software/dante-virtual-soundcard>

Wireless control: While the mixer does not support simultaneous wireless and Dante Ethernet connectivity you can connect a control computer wirelessly using a wireless access point connected to your network switch.

Note: in order to use a wireless access point on a Dante network special care must be taken to filter the Dante packets and avoid flooding the wireless network. Please refer to the Audinate "Configuring ACL filtered VLANs for Multicast Traffic Management" document.

Multiple AI Console & RM AVB Networked Mix Systems — Coming Q2 2015

AVB recording can be done with a compatible Mac computer using the built-in Core Audio support. Any Mac computer with a Thunderbolt port running OS 10.9 or later is supported. AVB recording to a PC currently requires 3rd party Ethernet cards and drivers.

Wireless control: While the mixer does not support simultaneous wireless and AVB Ethernet connectivity you can connect a control computer wirelessly using a wireless access point connected to your network switch. **Note:** because AVB switches are designed to manage the AVB traffic along with standard network traffic there's no need for special configuration to support a wireless access point.



MAIN PERFORMANCE ROOM

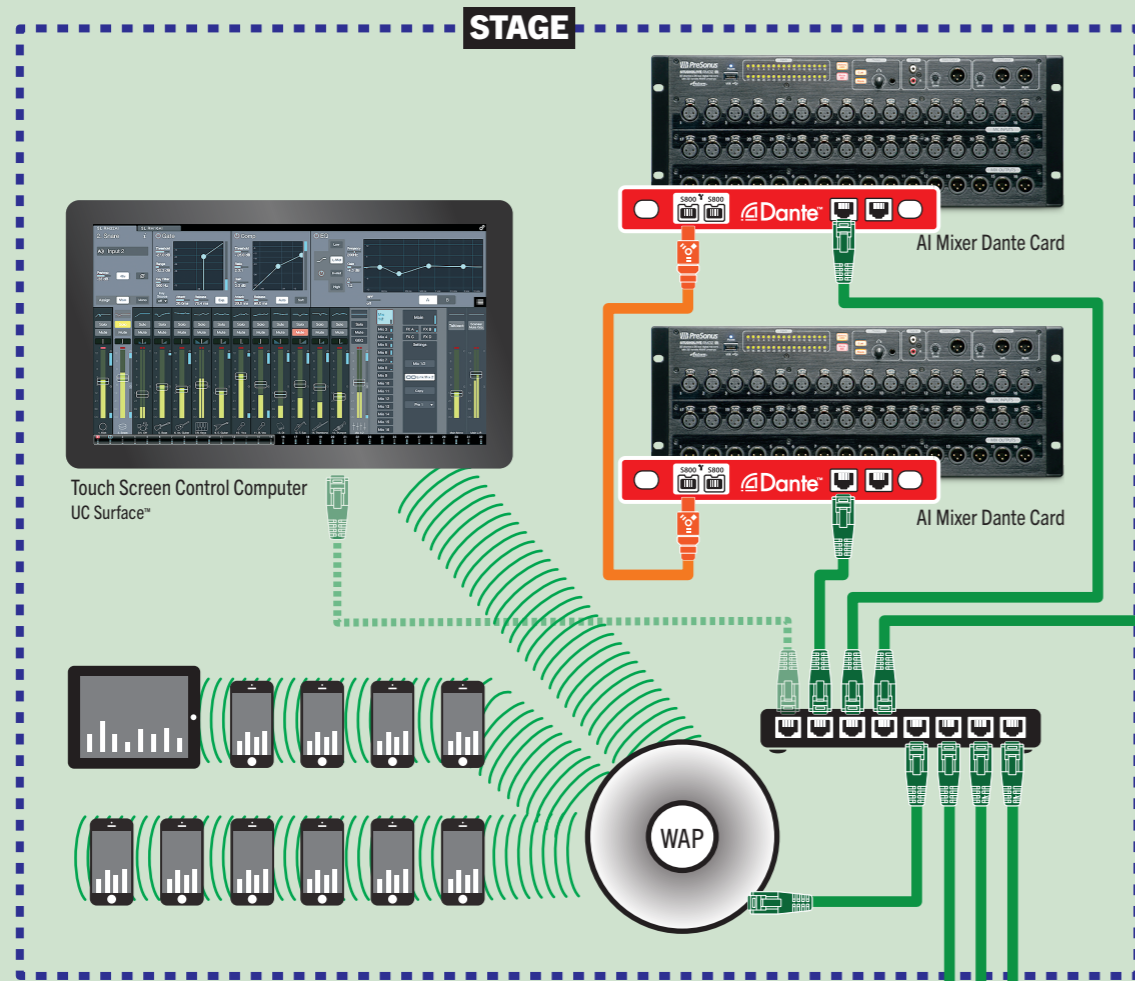

FRONT OF HOUSE

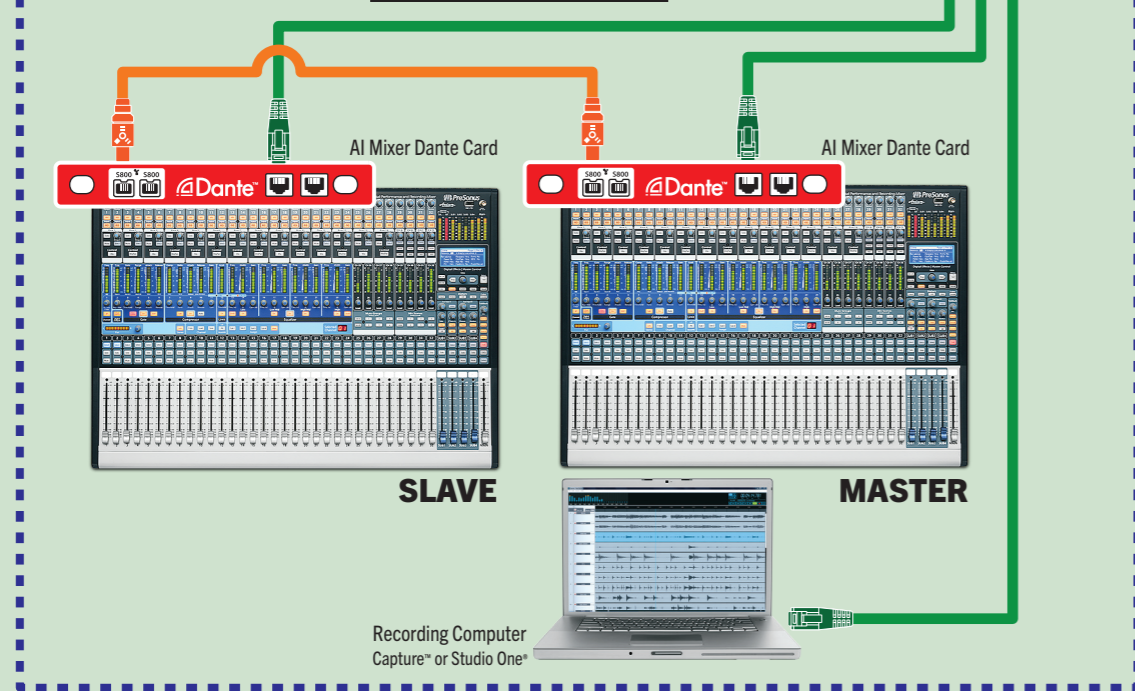

SMALL PERFORMANCE ROOM

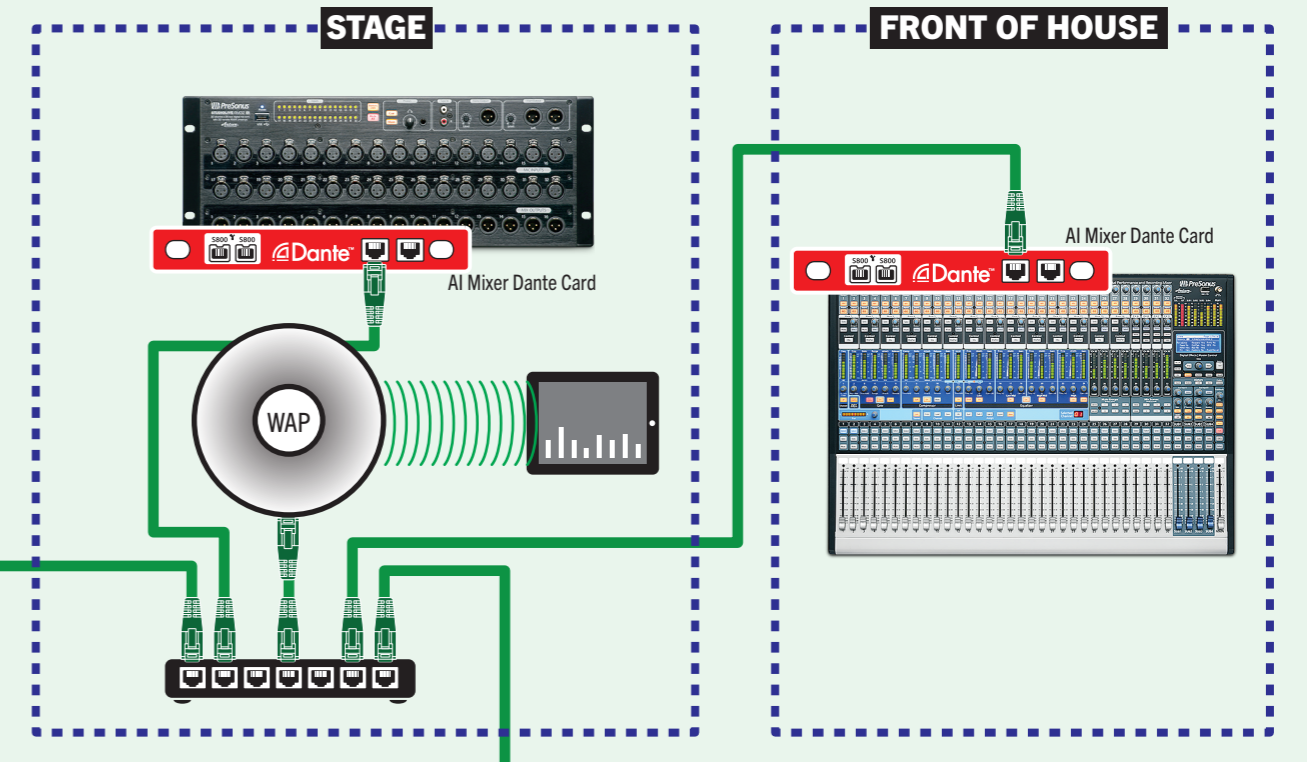

BROADCAST / RECORDING ROOM

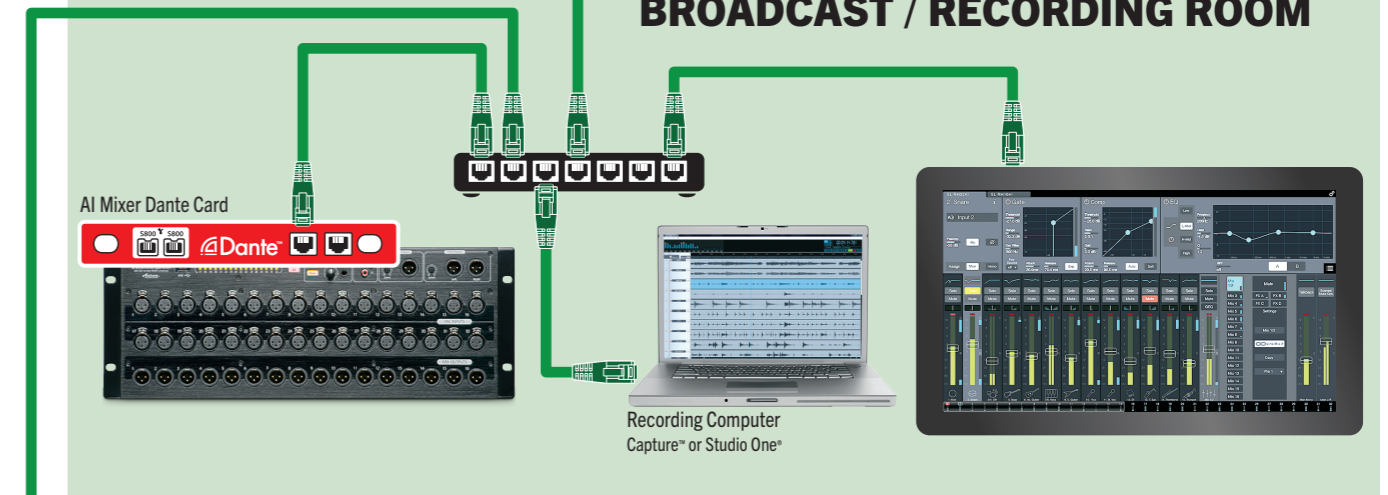

MOBILE PERFORMANCE / RECORDING RIG

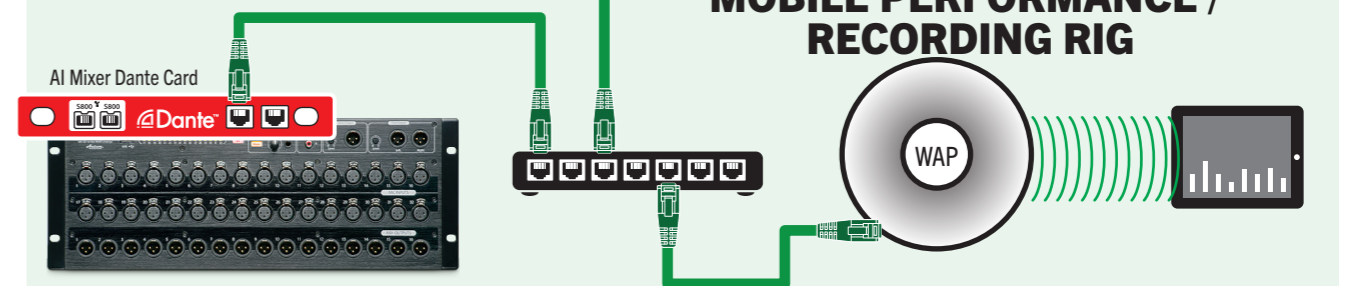

MAIN PERFORMANCE ROOM

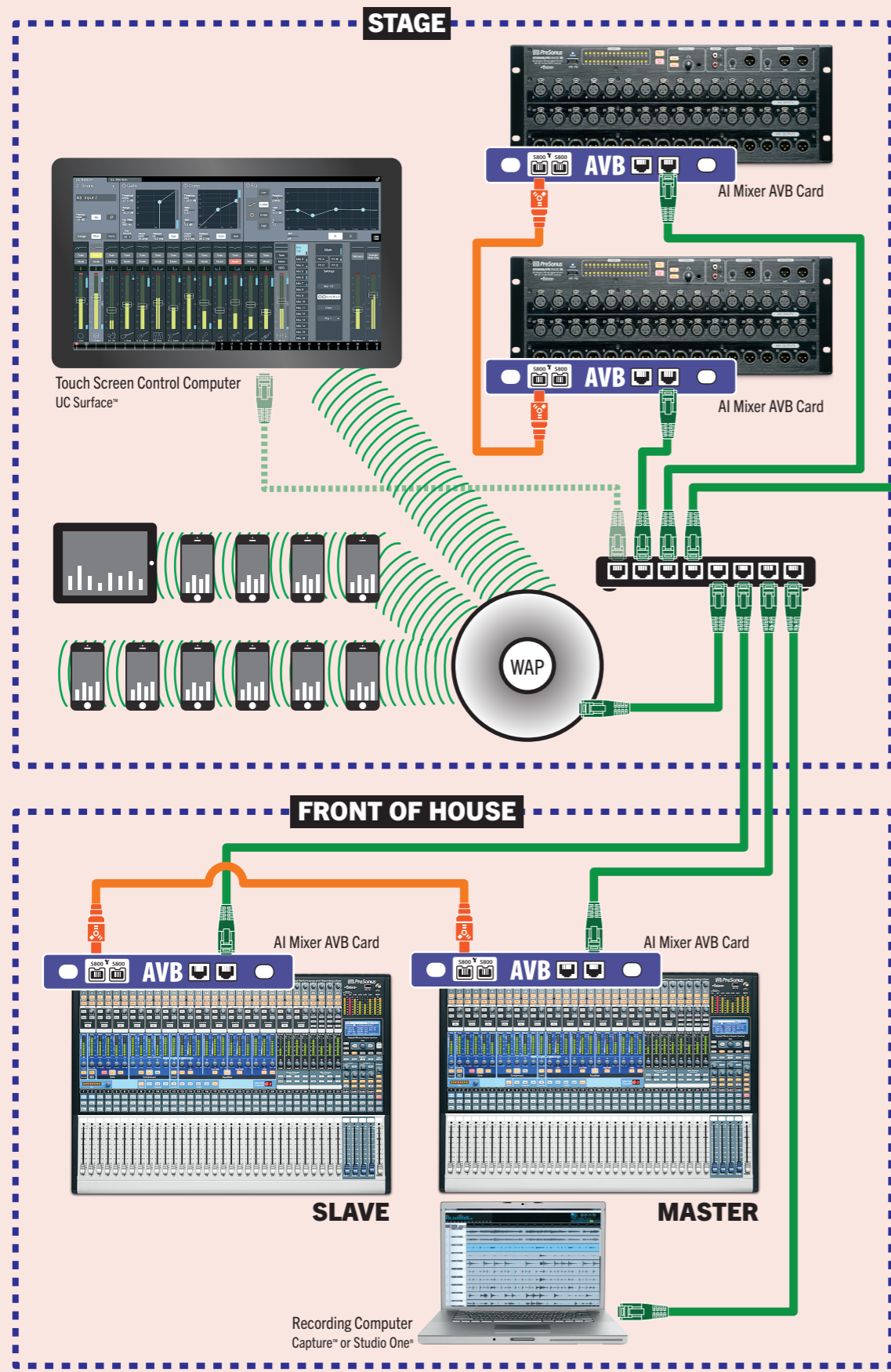

SMALL PERFORMANCE ROOM

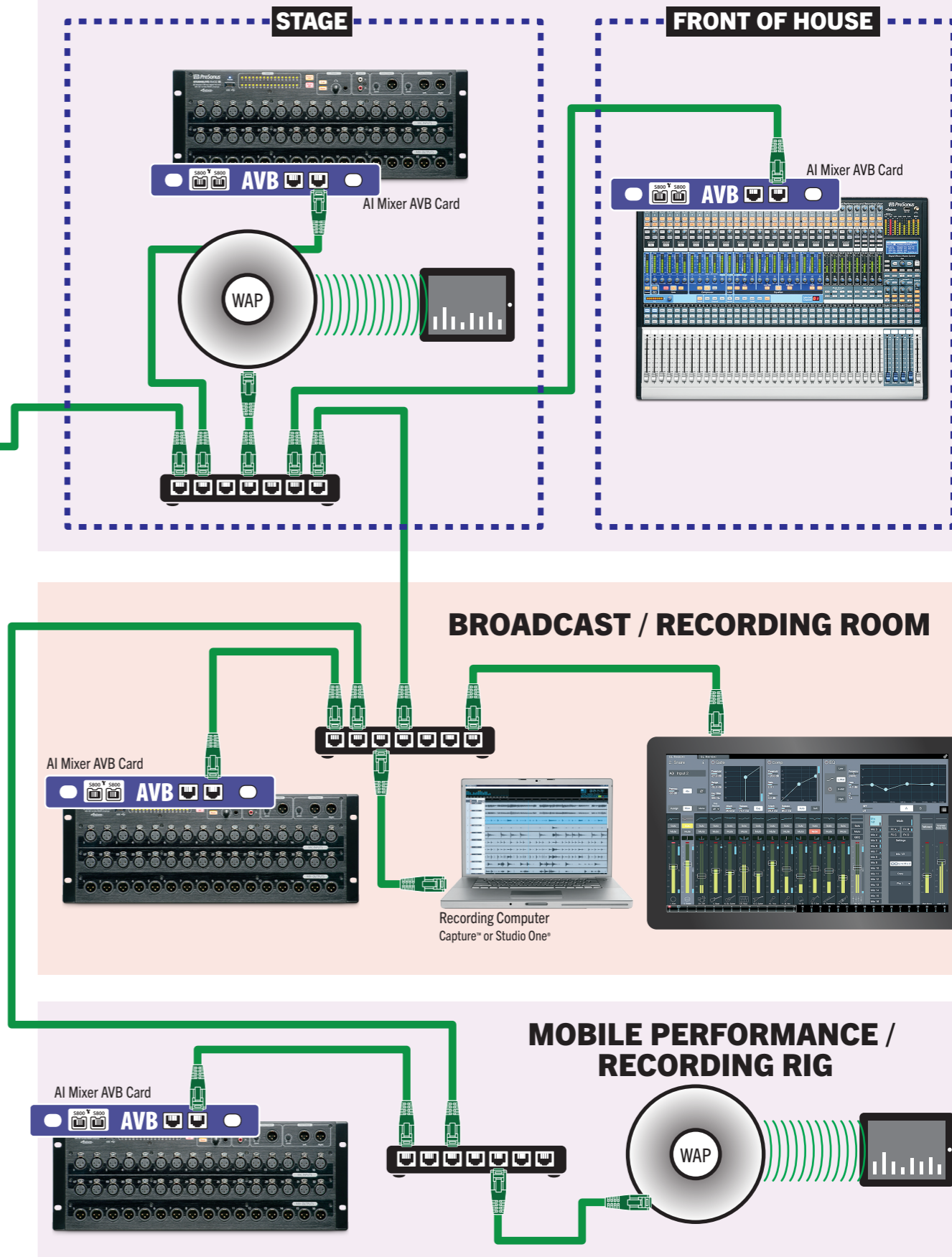

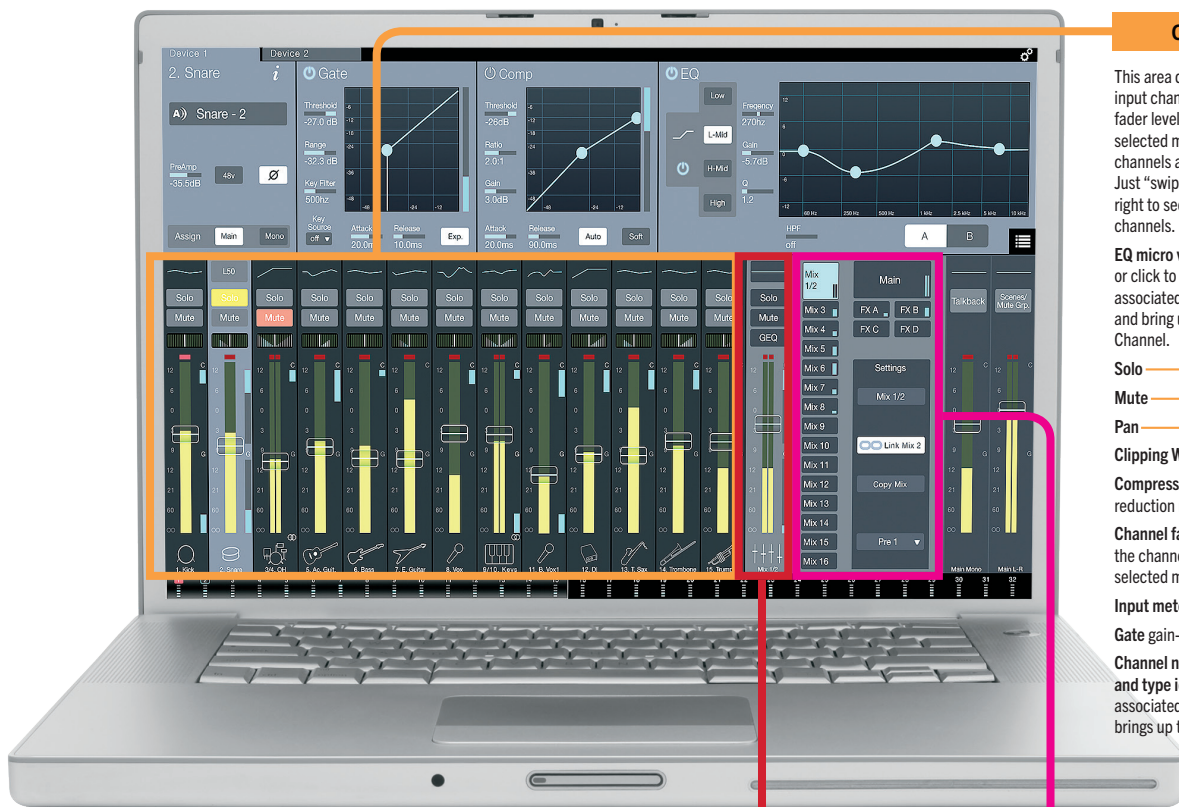

Channel Strip Section

This area displays the input channels and fader levels for the selected mix, multiple channels at a time. Just "swipe" left or right to see other channels.

EQ micro view. Touch or click to select the associated channel and bring up the Fat Channel.

Solo

Mute

Pan

Clipping Warning

Compressor gain-reduction meter

Channel fader. Controls the channel level for the selected mix.

Input meter

Gate gain-reduction meter

Channel number, name, and type icon. Selects the associated channel and brings up the Fat Channel.

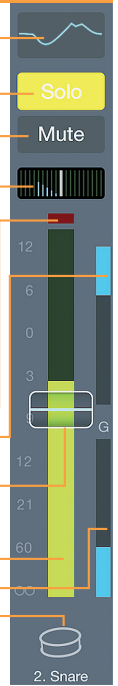

UC surface

We chose the term "battle-ready" to describe UC Surface because it's the first on-screen mix control application to truly handle the spontaneous and often chaotic demands of live mixing.

All primary mixing functionality is at your fingers without the need to navigate complex views or deep menus.

Displays automatically change context depending on what you're trying to adjust.

And you can see all critical level functions at a glance.

You can simultaneously run Front of House from a touch screen, mix monitoring from a laptop to the side or on-stage and also roam around the venue with an iPad.



18011 Grand Bay Court
Baton Rouge, LA 70809
tel 225-216-7887
fax 225-926-8347
support@presonus.com
www.presonus.com

Flex Master Channel Strip

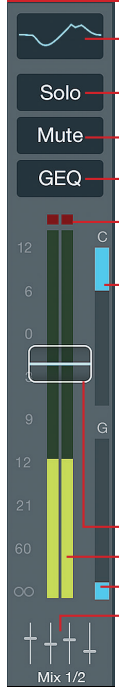

The Flex Master channel strip shows the master channel for the selected mix. For example, when Mix 3 is selected, the Flex Master is the main output for Mix 3.

EQ micro view. Selects the associated Mix master and brings up the Fat Channel.

Solo

Mute

GEQ or FX Edit. Opens the associated graphic EQ or effects editor in the Fat Channel area.

Clipping warnings.

Compressor gain-reduction meter

Mix fader

Output meter

Gate gain-reduction meter

Mix number, name, and type icon. Selects the associated Mix master and brings up the Fat Channel.

Mix Selection Area



This is the primary navigation area for RM mixers. Here you select the mix that's currently being controlled by the channel faders. This is also where you'll find the settings for each mix.

Mix selection buttons

Main Mix Select button

FX Mix selection buttons

Mix settings and Filter Groups area includes...

Mix name. Select to rename.

Stereo Link. Select to link two adjacent mixes for stereo operation.

Copy/Paste. Copies the currently selected mix so you can paste into other mixes.

Mix Position. Selects routing position for the selected mix (Pre 1, Pre 2, Post).

The Meter Bridge shows the input meters for all available channels. A highlighted window shows the channels that are currently displayed in the input channel area. You can use the Meter Bridge to navigate to a specific channel by selecting the channel to "jump" the input channel view to that area or drag the highlighted window to scroll to that area. You can also swipe the input channel area to scroll through the available channel, and the highlighted window in the Meter Bridge will follow your location.

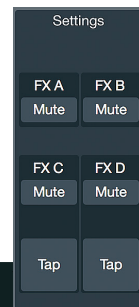

FX Settings. When an FX mix is selected, this area provides quick access to all FX mutes and Tap Tempo buttons for the delay effects.