

IML Series for Fixed Sound Installations

For Boardrooms, Teleconferencing & Government Facilities

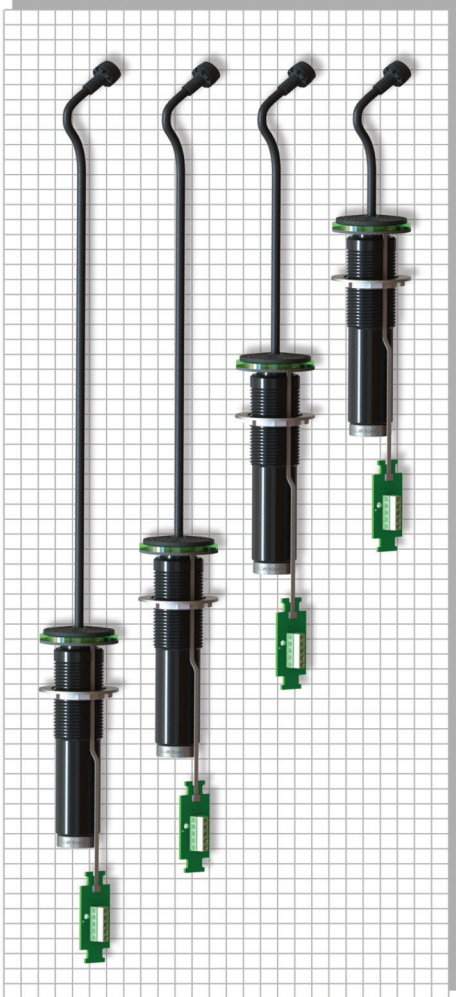

Architectural & Engineering Specifications

30kHz Cardioid

The microphone shall be a back-electret condenser type with a wide-range uniform frequency response of 30 Hz to 30 kHz ± 2 dB and shall have an output level of 10mV/Pa. The microphone shall be of a single capsule, single membrane design with an impulse response rise time no longer than 25 microseconds, and total settling time, including rise time, no longer than 120 microseconds. The microphone shall have polar characteristics uniform in all planes to form a cardioid of revolution and shall accept sound pressure levels up to 145dB producing no more than 3%THD. It shall have a LumiComm™ dual-color touch ring with colors of red and green which are externally powered by 7-28 VDC @ 85-170mA via a Phoenix or RJ45 connector mounted on the microphones external pc board. The touch-ring will emit a momentary digital pulse from its external pc board connector to activate external systems or equipment. The microphone body threading shall use the NPT standard of 1.660 in. (42.16mm) outer diameter 0.08696 in. (2.20878mm) thread pitch. The microphone shall be terminated with a male XLR-3 connector and shall require 48V phantom power. The microphone is available in gooseneck lengths of 3, 6, 10 & 12 inches (full product dimensions of back of this sheet). The microphone shall be made of metal with black finish. The Earthworks IML3-B, IML6-B, IML10-B or IML12-B is specified.

- High Definition Microphones™ for Conference Rooms and Fixed Sound Installations
- Near-perfect Polar Response (uniform frequency response at 0°, 45° & 90°)
- Very High Intelligibility
- LumiComm™ LED Touch Ring (dual colors of red and green)
- Can be Installed in Conference Tables (includes lock nut)
- More Gain Before Feedback
- High Rejection of Sounds from the Rear of the Microphone
- 30Hz to 30kHz Frequency Response
- RF Shielding against cell phones and other RF devices
- 145dB Max Acoustic Input
- Requires 48V Phantom Power
- Fifteen Year Warranty

Earthworks IML Series™ Installation Microphones

The IML Series™ provides a low profile, pristine sounding microphone solution for permanent sound installations. The extended flat frequency response and near-perfect polar response allows orators to maintain the same intelligibility at the front and sides of the microphone without a loss of high frequencies, while obtaining more gain before feedback. The IML Series Installation microphones provide a 30Hz to 30kHz frequency response, with pristine audio in an attractive low-profile package with options of 3 in., 6 in., 10 in. or 12 in. mini-goosenecks. The LumiComm™ dual color Touch Ring LED is touch sensitive and is powered from an external power source of 7 to 28VDC @ 85-170 mA (current is dependent upon number of LEDs illuminated at one time). The IML High Definition Microphones™ provide exceptional sound quality, with very high intelligibility, high rejection of sounds at the rear of the microphone, more gain before feedback and near-perfect polar response.

High Definition Microphones™ for Fixed Sound Installations

The Earthworks IML Series™ High Definition Microphones™ is the ideal choice for high

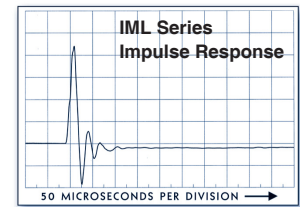
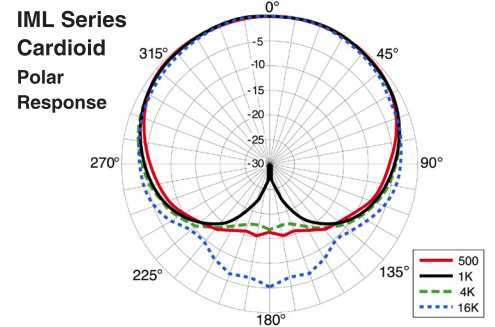

quality sound system installations. The IML microphone's uniquely designed small head and flexible noise-free mini-gooseneck allow it to be easily positioned. The IML mics' near-perfect polar response will not beam or spotlight and will provide high intelligibility. The frequency response at 90 degrees off-axis is within 2dB of the on-axis response (over its entire operating frequency range). This exceptional polar response allows the use of fewer microphones, while obtaining higher intelligibility and more gain before feedback. The IML Series™ is the perfect solution for conference tables, conference rooms and a wide variety of sound installations, while providing the ultimate in sound quality.

Near-Perfect Polar Response

David Blackmer invented a number of new microphone technologies resulting in a totally new approach to microphone design. One such technology resulted in the creation of near-perfect polar patterns. When you look at a polar pattern of an Earthworks microphone, the mid-frequencies, high-frequencies and low-frequencies all look very close to a "textbook" perfect polar pattern. In practice this means the polar response of an Earthworks microphone is extremely uniform over its operating frequency range; the frequency response at 90 degrees off-axis is very close to the on-axis response. This uniform polar response results in less phase problems and much higher intelligibility at the sides of the microphone.

Specifications & Dimensions are on back of this page





IML Series High Definition Microphones™ For Conference Rooms & Fixed Sound Installations

IML3-B Dimensions

IML10-B Dimensions

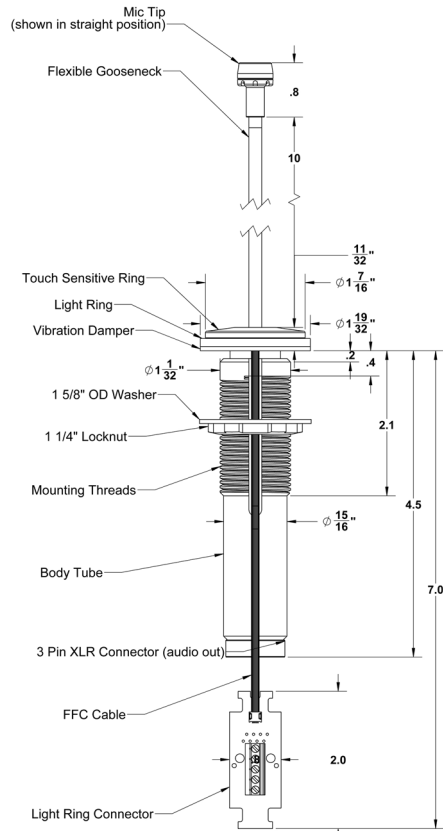
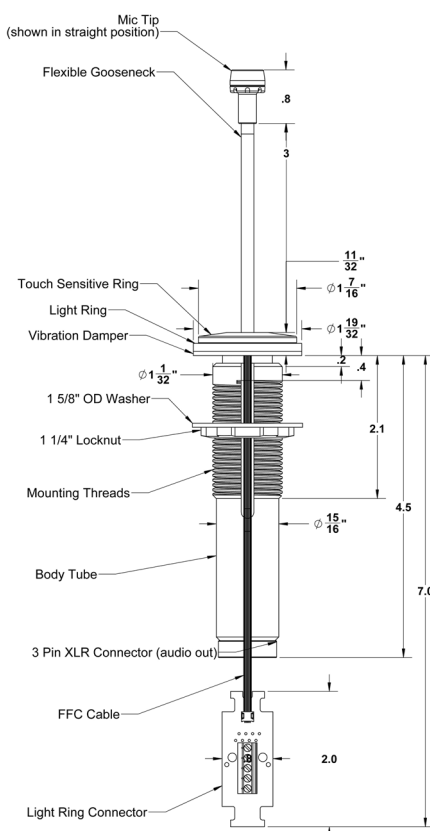
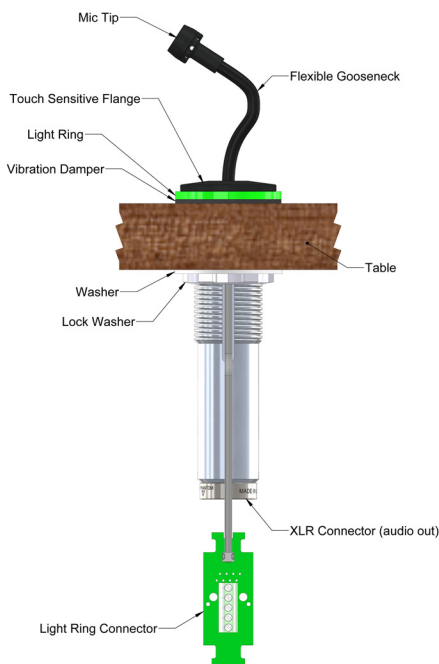

The light-ring emits a momentary digital pulse to the connector on the pc board to activate external control systems or equipment.

Special Order Options include custom mic colors, custom gooseneck lengths and other light ring LED colors.

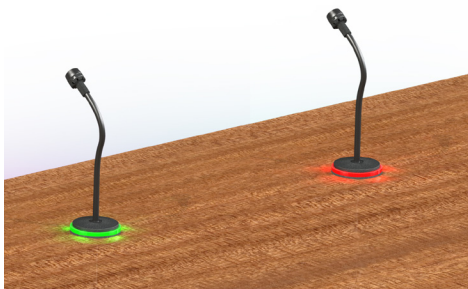

IML6-B Dimensions

IML12-B Dimensions

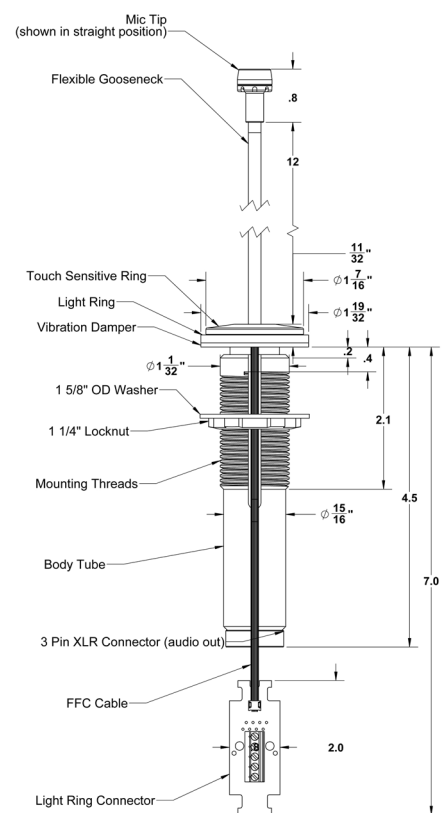
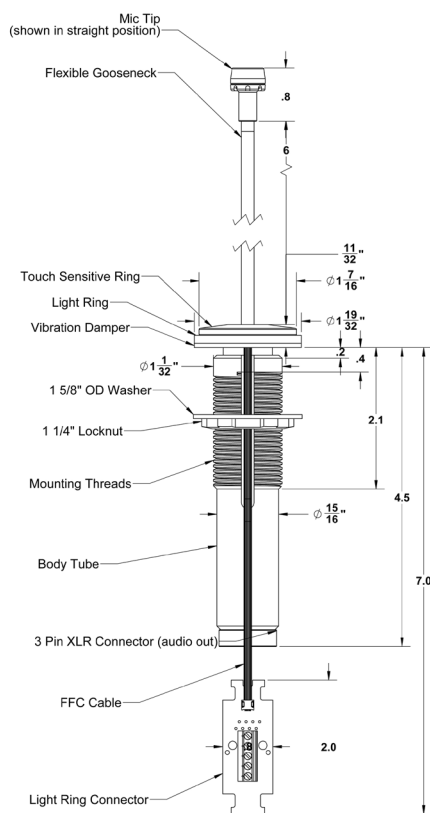

IML SERIES SPECIFICATIONS

Frequency Response:	30Hz to 30kHz ± 2dB @ 1 ft. (30cm)
Polar Pattern:	Cardioid
Sensitivity:	10mV/Pa (-40dBV/Pa)
Power requirements:	48V Phantom, 10mA
Max Acoustic Input:	145dB SPL
Output:	XLR-3 (pin 2+)
Min. Output Load:	600 ohms between pins 2 & 3
Noise:	22dB SPL (A weighted)
Light Ring LED Colors	Dual Red & Green
Light Ring Connector:	Phoenix or RJ45
Light Ring Voltage:	7-28VDC @ 85-170mA
Light Ring Activation	
Signal	Momentary Digital Response
Microphone Color	Black (other colors on special order)
Dimensions:	See Drawings at right
Weight:	0.28 lbs. (125g)