

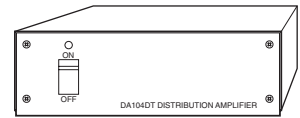

C605SM (6/99) DA104DT Distribution Amplifier



3500 Pelco Way
Clovis, CA 93612 USA

In North America & Canada:
Tel (800) 289-9100
FAX (800) 289-9150

International Customers:
Tel (1-559) 292-1981
FAX (1-559) 348-1120
DataFAX (1-559) 292-0435

Pelco Online
www.pelco.com

MAINTENANCE

The DA104DT requires no periodic maintenance. In the event of any apparent amplifier failure, check all cables and connectors first.

Before any attempt is made to troubleshoot the circuitry, check for a proper video signal at the input.

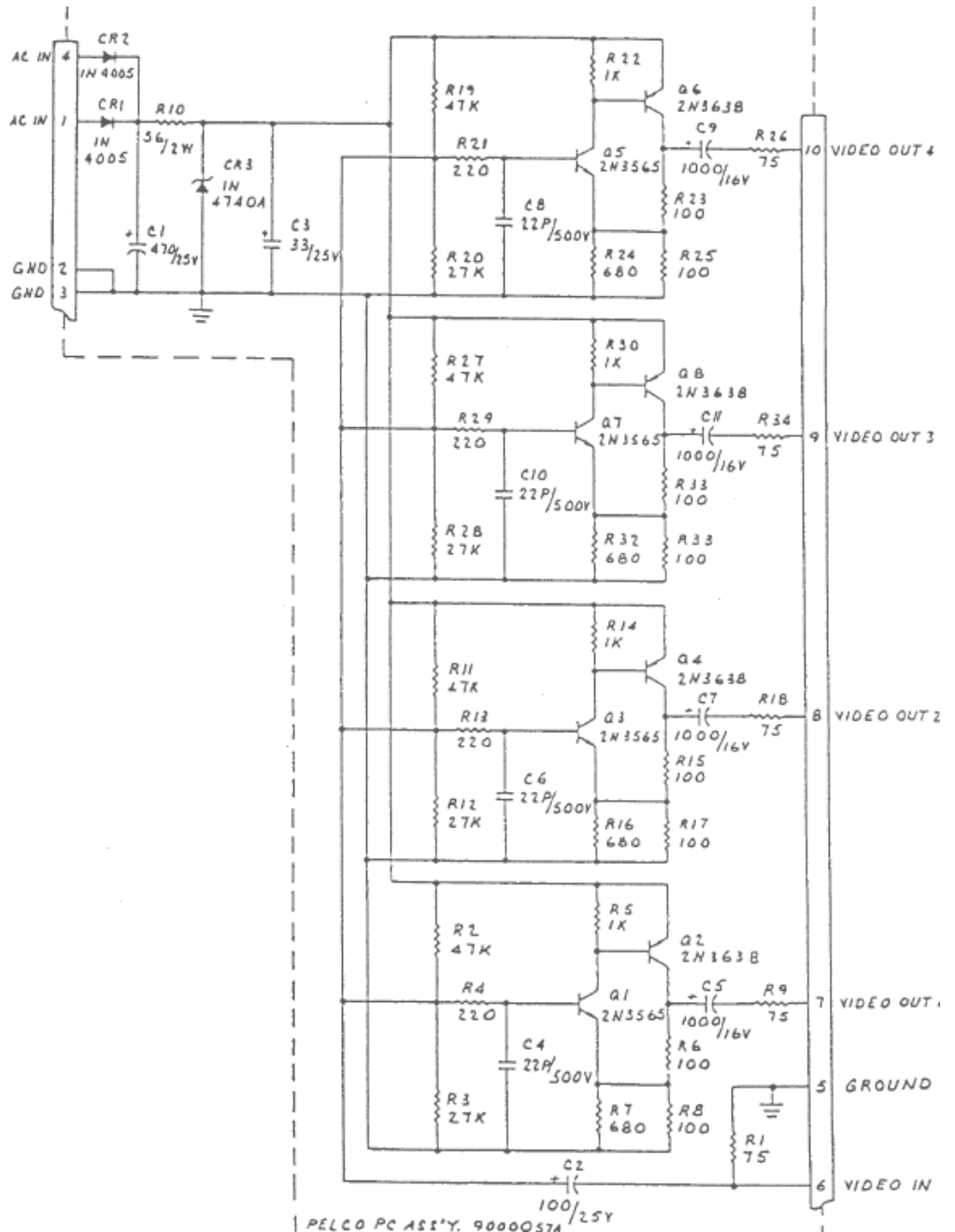

Figure 1. PCB9000057A Component Layout

Table A. Electrical Parts List

Symbol	Description	Part Number
C1-C4	Capacitor 22 pf, 500 VDC	CAPP0022.0/500
C5	Capacitor 100 mf, 25 VDC	CAPU0100.0/25
C6	Capacitor, 470 mf, 25 VDC	CAPU0470.0/25
C7-C10	Capacitor, 1000 mf, 16 VDC	CAPU1000.0/16
D1-D2	Diode	DIO4005
CR200	Diode	DIO4740
—	PC Board	PCB9000057
Q1-Q4	Transistor	TRA3565
Q5-Q8	Transistor	TRA3638
R1	Resistor, 56 ohm, 5% 2W	RES056.0-2
R2-R6	Resistor, 75 ohm, 5% 1/4W	RES075.0-25
R7-R14	Resistor, 100 ohm, 5% 1/4W	RES100.0-.25
R15-R18	Resistor, 220 ohm, 5% 1/4W	RES220.0-.25
R20-R23	Resistor, 680 ohm, 5% 1/4W	RES680.0-.25
R24-R27	Resistor, 1K ohm, 5% 1/4W	RES001.0K.25
R28-R31	Resistor, 27K ohm, 5% 1/4W	RES027.0K.25
R32-R35	Resistor, 47K ohm, 5% 1/4W	RES047.0K.25
S1	Switch	SWI7201J1ZQ
T1	Transformer (120 VAC input only)	TRF112.0M0.1
	Transformer (230 VAC input only)	TRF212.0M0.1
F1	Fuse .2 amp, Slow-blow	FUS2/10SB

PRODUCT WARRANTY AND RETURN INFORMATION

WARRANTY

Pelco will repair or replace, without charge, any merchandise proved defective in material or workmanship for a period of one year after the date of shipment.

Exceptions to this warranty are as noted below:

- Five years on FT/FR8000 Series fiber optic products.
- Three years on GenexSM Series products (multiplexers, server, and keyboard).
- Three years on CamclosureSM and fixed camera models, except the CC3701H-2, CC3701H-2X, CC3751H-2, CC3651H-2X, MC3651H-2, and MC3651H-2X camera models, which have a five-year warranty.
- Two years on standard motorized or fixed focal length lenses.
- Two years on LegacySM, CM6700/CM6800/CM9700 Series matrix, and DF5/DF8 Series fixed dome products.
- Two years on SpectraSM, EspritSM, ExSiteSM, and PS20 scanners, including when used in continuous motion applications.
- Two years on EspritSM and VW5700 Series window wiper (excluding wiper blades).
- Eighteen months on DX Series digital video recorders, NVR300 Series network video recorders, and EnduraSM Series distributed network-based video products.
- One year (except video heads) on video cassette recorders (VCRs). Video heads will be covered for a period of six months.
- Six months on all pan and tilts, scanners or preset lenses used in continuous motion applications (that is, preset scan, tour and auto scan modes).

Pelco will warrant all replacement parts and repairs for 90 days from the date of Pelco shipment. All goods requiring warranty repair shall be sent freight prepaid to Pelco, Clovis, California. Repairs made necessary by reason of misuse, alteration, normal wear, or accident are not covered under this warranty.

Pelco assumes no risk and shall be subject to no liability for damages or loss resulting from the specific use or application made of the Products. Pelco's liability for any claim, whether based on breach of contract, negligence, infringement of any rights or product liability, relating to the Products shall not exceed the price paid by the Dealer to Pelco for such Products. In no event will Pelco be liable for any special, incidental or consequential damages (including loss of use, loss of profit and claims of third parties) however caused, whether by the negligence of Pelco or otherwise.

The above warranty provides the Dealer with specific legal rights. The Dealer may also have additional rights, which are subject to variation from state to state.

If a warranty repair is required, the Dealer must contact Pelco at (800) 289-9100 or (559) 292-1981 to obtain a Repair Authorization number (RA), and provide the following information:

1. Model and serial number
2. Date of shipment, P.O. number, Sales Order number, or Pelco invoice number
3. Details of the defect or problem

If there is a dispute regarding the warranty of a product which does not fall under the warranty conditions stated above, please include a written explanation with the product when returned.

Method of return shipment shall be the same or equal to the method by which the item was received by Pelco.

RETURNS

In order to expedite parts returned to the factory for repair or credit, please call the factory at (800) 289-9100 or (559) 292-1981 to obtain an authorization number (CA number if returned for credit, and RA number if returned for repair).

All merchandise returned for credit may be subject to a 20% restocking and refurbishing charge.

Goods returned for repair or credit should be clearly identified with the assigned CA or RA number and freight should be prepaid. Ship to the appropriate address below.

If you are located within the continental U.S., Alaska, Hawaii or Puerto Rico, send goods to:

Service Department
Pelco
3500 Pelco Way
Clovis, CA 93612-5699

If you are located outside the continental U.S., Alaska, Hawaii or Puerto Rico and are instructed to return goods to the USA, you may do one of the following:

If the goods are to be sent by a COURIER SERVICE, send the goods to:

Pelco
3500 Pelco Way
Clovis, CA 93612-5699 USA

If the goods are to be sent by a FREIGHT FORWARDER, send the goods to:

Pelco c/o Expeditors
473 Eccles Avenue
South San Francisco, CA 94080 USA
Phone: 650-737-1700
Fax: 650-737-0933

REVISION HISTORY

Manual #	Date	Comments
C605SM	6/99	Original version.