



The AFGS Suspension Grid System is an adjustable aiming system for loudspeakers, which includes load rated spokes and arms that position loudspeakers into a spherical array. The outer radius of the AFGS Grid establishes a simulated common point of origin for the sound, allowing sound to arrive at the destination at the same moment.

AFGS Spherical arrays are a perfect solution for center clusters because they place loudspeakers in a horizontal plane and at a higher elevation than line arrays, which hang vertically and can obstruct lines of sight.

Because of the AFGS Grid's architecturally pleasing appearance, it is used in a wide variety of venues, including theaters, houses of worship, sport arenas, convention centers, auditoriums and theme parks.

# AFGS Grid

## Architectural Flying Grid System

The AFGS Grid and its payload are supported from either three or four load-rated suspension points. These suspension points may also be bridled in a number of ways to reduce the actual suspension points to two. The use of turnbuckles allows installers to set a perfectly level overhead grid with a high degree of precision in setting angles to precisely aim loudspeakers.

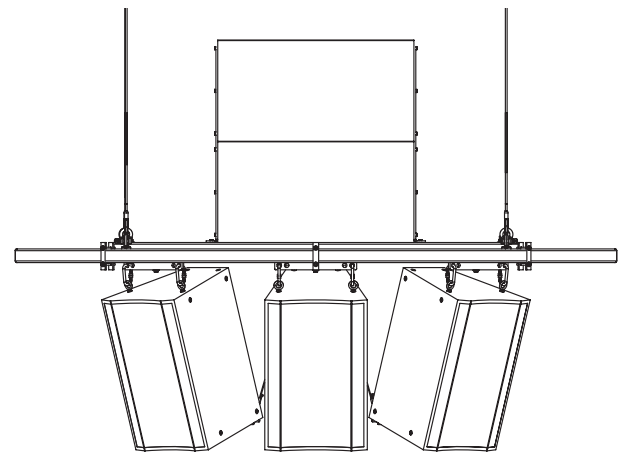

AFGS Grids can be bolted together into a full circle using an optional hardware kit, joining two grids to gain a full 360 degrees of sound coverage. Multiple tiers can be created by place one larger AFGS Grid over a smaller grid. This is especially useful with stadium seating.

360° Cluster  
USE AFGS - 30/46-KIT

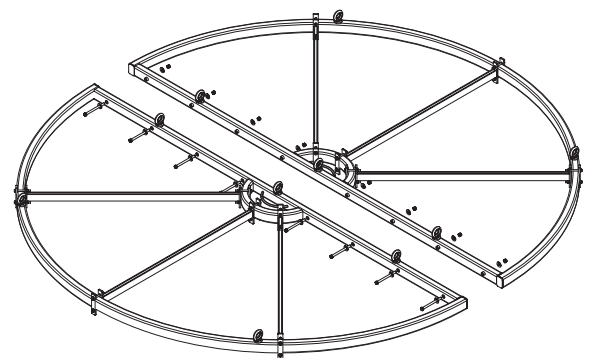
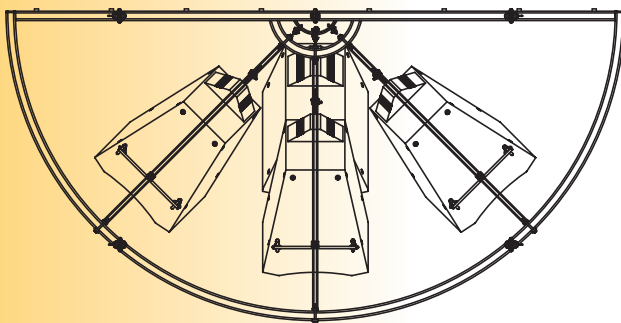

A division of:  
**ADAPTIVE TECHNOLOGIES GROUP**

1635 E. Burnett Street  
Signal Hill, CA 90755 USA  
PH: 562.424.1100 FX: 562.424.3520

**ATM**  
**FLY-WARE®**

[www.atmflyware.com](http://www.atmflyware.com)

# AFGS GRID AND SPOKE DIMENSIONS

**TABLE A**

Dimensions	30" GRID	46" GRID	66" GRID
<b>GRID</b>	<b>AFGS-30G</b>	<b>AFGS-46G</b>	<b>AFGS-66G</b>
<b>WLL*</b>	3000 lb./1361 Kg	2000 lb./907 Kg	1350 lb./612 Kg
<b>SPOKE</b>	<b>AFGS-30S</b>	<b>AFGS-46S</b>	<b>AFGS-66S</b>
<b>WLL*</b>	1100 lb./498 Kg	575 lb./260 Kg	355 lb./160 Kg
<b>A</b>	30"/76 cm	46"/117 cm	66"/168 cm
<b>B</b>	60"/152 cm	92"/234 cm	132"/336 cm
<b>C</b>	21.22"/54 cm	33.5"/85 cm	48.9"/124 cm
<b>D</b>	16.83"/43 cm	28.92"/73 cm	41.79"/106 cm
<b>E</b>	14"/36 cm or 18"/46 cm	18"/46 cm or 24"/61 cm	30"/76 cm or 36"/91 cm
<b>See Table 'B'</b>	AFGS-14A AFGS-18A	AFGS-18A AFGS-24A	AFGS-30A AFGS-36A

Add a "-W" to order this part in white.  
\* Working Load Limit

AFGS spokes and steerable arms provide an infinite range of speaker aiming. Using one spoke for each loudspeaker, the spokes clamp to the inner and outer radius sections of the grid and bolt down in the specific angle that the loudspeaker will be aimed. The size and down tilt angle of the selected loudspeaker are the only limits as to how many speakers can be flown from the Grid.

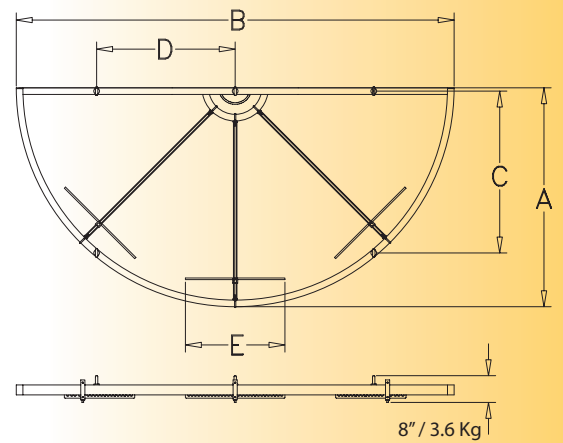

# AFGS ARM DIMENSIONS

Each loudspeaker is suspended from an independent steering arm, which pivots horizontally from an adjustable spoke. Spokes point the loudspeaker into the desired pan angle and the arm provides additional tuning or to sweep back from

either side to reach beyond a 180 degree coverage. Use the distance between the loudspeaker's suspension points to determine which arm to select.

**TABLE B**

PART #	A	B	C	D	WLL*
<b>AFGS-14A</b>	12.75"/32 cm	9.5"/24 cm	6.25"/16cm	14.38" / 37 cm	
<b>AFGS-18A</b>	16"/41 cm	12.75"/ 32 cm	—	18" /46 cm	560 lb. / 253 Kg
<b>AFGS-24A</b>	22"/56 cm	18.75" / 48cm	—	24" /61 cm	410 lb. / 186 Kg
<b>AFGS-30A</b>	28"/71 cm	24.75" / 63 cm	—	30" / 76 cm	325 lb. / 147 Kg
<b>AFGS-36A</b>	34"/86 cm	30.75" / 78 cm	—	36" / 91 cm	265 lb. / 120 Kg

Add a "-W" to order this part in white.  
\* Working Load Limit

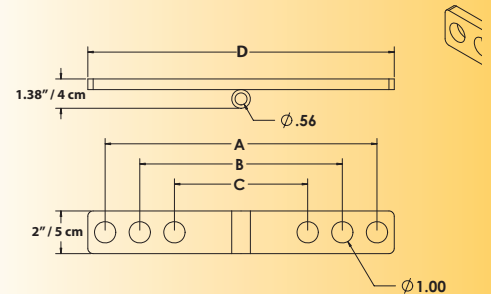

ALWAYS USE SAFETY CABLES.

**WARNING:** Mounting and/or suspension of audio and video equipment requires experienced professionals. Improperly installed equipment can result in property damage, personal injury and/or liability to the installing contractor.

A division of:  
**ADAPTIVE TECHNOLOGIES GROUP**

1635 E. Burnett Street  
Signal Hill, CA 90755 USA  
PH: 562.424.1100 FX: 562.424.3520



www.atmflyware.com

# AFGS TILT OPTIONS

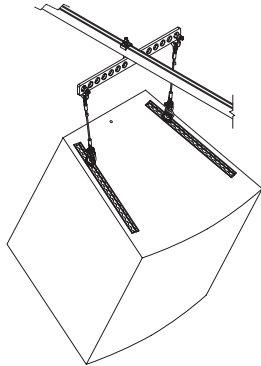

Vertical aiming is achieved in one of two ways, based on the loudspeaker's suspension style. For loudspeakers equipped with fly track, wire rope assemblies are secured between the track's fitting inside the track and the steering arm. Placement of the track fitting dictates the loudspeaker's down angle.

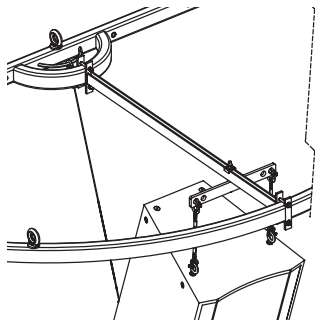

For loudspeakers with left to right suspension points, wire rope assemblies are secured between the loudspeaker and the steering arm. A third wire rope assembly, known as a Tilt Cable Coupler (CC-096), connects between the back of the loudspeaker and the Grid's pull-back rail. Cable couplers lock loudspeakers into precise down angles.

*Note: If the loudspeaker is aimed off the centerline of the spoke, select the Tilt Cable Kit (TCK), which secures to loudspeaker to the arm only.*

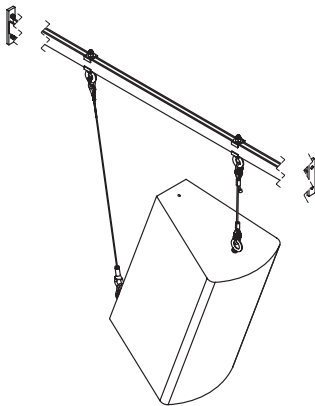

For loudspeaker cabinets with two suspension points, front to back, just one wire rope assembly is required and suspends to an AFGS-ARM-POINT instead of the steerable arm. The loudspeaker is tilted using the Tilt Cable Coupler (CC-096) between the speaker and the Grid's pull-back rail.

*Note: If the loudspeaker is aimed off the centerline of the spoke, select the Tilt Cable Kit (TCK), which secures the loudspeaker to the arm only.*

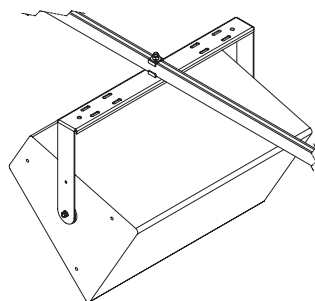

In some cases, loudspeakers come equipped with a U-Bracket, which can be secured directly to the AFGS spoke in place of the AFGS arm. An AFGS-BRKT-KIT bolt kit will be required to secure the bracket to the spoke. A 1/2" diameter hole in the center of the base of the U-Bracket will be required to accommodate the AFGS-BRKT-KIT.

# REQUIRED HARDWARE

## EYEBOLT

EB-375 2 Per Speaker

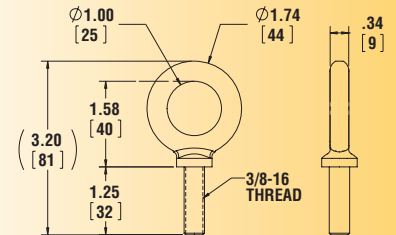

## AFGS ARM POINT

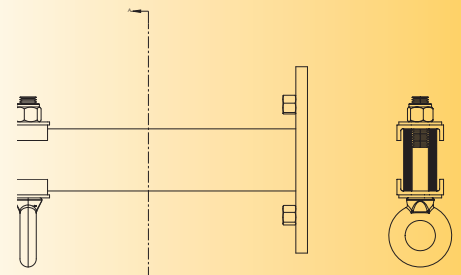

## CARABINER

OPS-Carabiner 2 Per Speaker

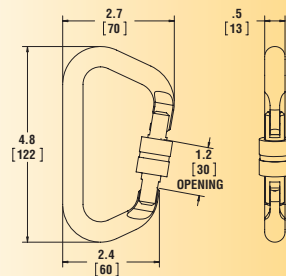

## TILT CABLE COUPLER

CC-096 1 Per Speaker

