

# 1032B

Operating Manual  
Genelec 1032B  
Monitoring Speaker

# GENELEC®



# Genelec 1032B Monitoring Speaker

## System

The bi-amplified GENELEC 1032B is a two way active monitoring speaker designed for high output, low coloration and broad bandwidth. It is based on the famous 1031A near field monitor but offers extended low frequency output with an increased maximum SPL.

Due to its compact size, integrated construction, excellent dispersion and precise stereo imaging this speaker system is ideal for Near Field monitoring, mobile vans, broadcast and TV control rooms and home studios. Designed as an active speaker, this unit contains drivers, power amplifiers, active crossover filtering and protection circuitry. The DCW™ Technology used provides excellent frequency balance even in difficult acoustic environments.

## Drivers

The low frequencies are reproduced by a 10" (250 mm) bass driver loaded in a 24 liters vented cabinet. The -3dB point lies at 40 Hz and the low frequency response extends down to 36 Hz (-6dB).

The high frequency driver is a 1" (25 mm) metal dome with pure piston behavior up to 23 kHz. The uniform dispersion control is achieved with the revolutionary DCW Technology pioneered by Genelec. The DCW also provides perfect phase and delay uniformity at the crossover frequency.

Both drivers are magnetically shielded.

## Crossover

The active crossover network consists of two parallel bandpass filters. Acoustically the filters are complementary and the slopes are 24 dB/octave. The crossover frequency is set to 1,8 kHz. Using the active crossover controls ('treble tilt', 'bass tilt' and 'bass roll-off') this speaker to be exactly matched to any room environment.

## Amplifiers

The amplifier unit is mounted to the rear of the speaker enclosure on quick release vibration isolators, to ensure rattle free operation and long term reliability. The bass and treble

amplifier produce respectively 180 W and 120 W of short term power. The fast, low distortion amplifiers are capable of driving a stereo system to peak output levels in excess of 124 dB SPL at 1 m. The unit incorporates a special protection circuitry for driver overload protection and amplifier thermal overload protection. Variable input sensitivity allows for accurate level matching to the console output section.

## Installation

Each 1032B monitor is supplied with a mains cable and an operating manual. After unpacking, place the speaker so that its acoustical axis (see figure 2) is aimed towards the listening position. Do not place the speaker in a horizontal position as this may cause acoustical cancellation problems around the crossover frequency.

Sufficient cooling for the amplifier must be ensured if the speaker is installed in a restricted space such as a cabinet or integrated into a wall structure. The minimum clearance for the amplifier is 10 centimeters (4") to any object. The space adjacent to the amplifier must either be ventilated or sufficiently large to dissipate heat so that the ambient temperature does not rise above 35 degrees Celsius (95°F).

Before connecting up, ensure that the mains switch is off (see figure 1). Check that the mains voltage selector is correctly set (Models sold in Europe have a fixed 230 V setting). **Audio input is via a 10 kOhm balanced XLR connector**, but unbalanced leads may be used as long as pin 3 is grounded to pin 1 of the XLR (see figure 3). Once the connection has been made, the speakers are ready to be switched on.

## Autostart function

The signal sensing Autostart function of the loudspeaker powers it up when playback begins. Automatic powering down of the loudspeaker happens one hour after the playback has ended and the loudspeaker goes to standby mode. The power consumption in standby mode is less than 0.5 watts. The loudspeaker will automatically and rapidly start once an input signal is detected from the source.

## Setting the input sensitivity

The input sensitivity of each speaker can be adjusted to match the mixing console output level or other source by using the input sensitivity control on the rear panel (see figure 1). A small screwdriver is needed for the adjustment. The manufacturer default setting for this control is -6 dBu (fully clockwise) which gives SPL of 100 dB @1m at -6 dBu input level. Note that to get the full output level of 113 dB SPL, an input level of +7 dBu is needed at this setting.

## Setting tone controls

The response of the system may have to be adjusted to match the acoustic environment. The adjustment is done by setting the three tone control switch groups 'treble tilt', 'bass tilt' and 'bass roll-off' on the rear panel. The factory settings for these controls are 'All Off' to give a flat anechoic response. See Table 1 for suggested tone control settings. Figure 5 shows the effect of the controls on the anechoic response. Always start adjustment by setting all switches to 'OFF' position. Then set only one switch to the 'ON' position to select the response curve needed. If more than one switch is set to 'ON' (within one switch group) the attenuation value is not accurate.

## Console top mounting

If the 1032B's are used for near field monitoring, avoid mounting the speakers on the meter bridge of the console. Instead position them slightly behind the console by using floor stands or wall mounts. This prevents the the first reflections from the console surface from coloring the direct sound.

## Maintenance

No user serviceable parts are to be found within the amplifier unit. Any maintenance or repair of the 1032B unit should only be undertaken by qualified service personnel.

## Safety considerations

Although the 1032B has been designed in accordance with international safety standards, to ensure safe operation and to maintain the instrument under safe operating con-

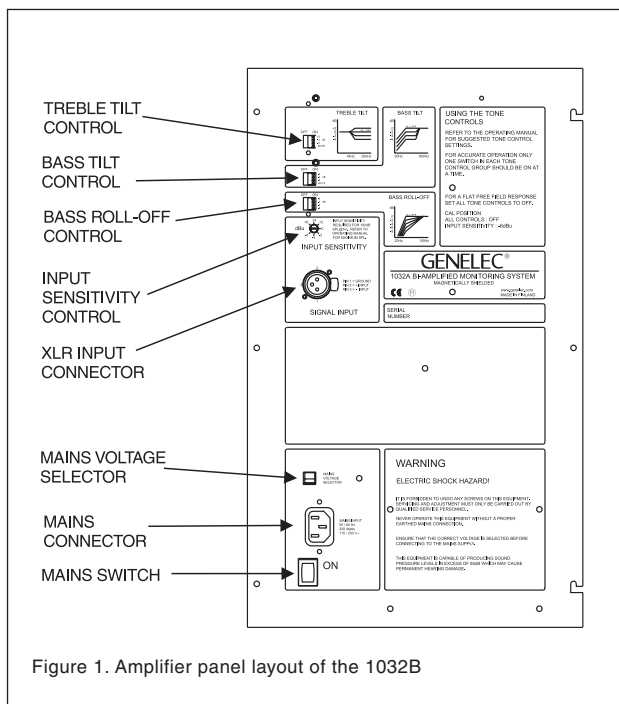

Figure 1. Amplifier panel layout of the 1032B

Speaker Mounting Position	Treble tilt	Bass tilt	Bass roll-off
Flat anechoic response	None	None	None
Free standing in a damped room	None	-2 dB	None
Free standing in a reverberant room	None	-4 dB	-2 dB
Near field or console bridge	None	-4 dB	-4 dB
In a corner	None	-4 dB	-4 dB

Table 1. Suggested tone control settings in some typical situations

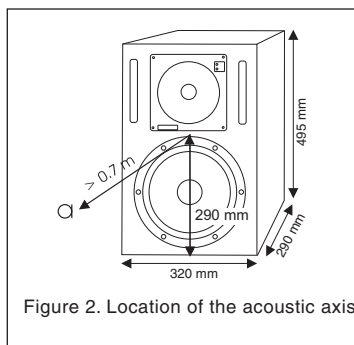

Figure 2. Location of the acoustic axis

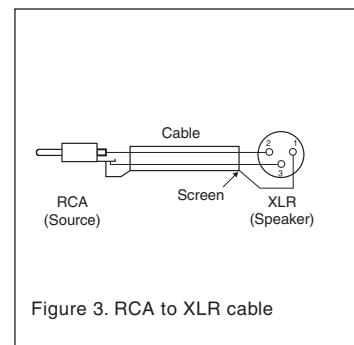

Figure 3. RCA to XLR cable

ditions, the following warnings and cautions must be observed:

1. Servicing and adjustment must only be performed by qualified service personnel. The amplifier's rear panel must not be opened.
2. Do not use this product with an unearthed mains cable or an unearthed mains connection as this may lead to personal injury.
3. To prevent fire or electric shock, do not expose the unit to water or moisture. Do not place any objects filled with liquid, such as vases on the speaker or near it.
4. Note that the amplifier is not completely disconnected from the AC mains service unless the mains power cord is removed from the amplifier or the mains outlet.

**WARNING!**

This equipment is capable of producing sound pressure levels in excess of 85 dB, which may cause permanent hearing damage.

**Guarantee**

This product is supplied with two year guarantee against manufacturing faults or defects that might alter the performance of the unit. Refer to supplier for full sales and guarantee terms..

**Compliance to FCC rules**

This device complies with part 15 of the FCC Rules. Operation is subject to the following two conditions:

This device may not cause harmful interference, and this device must accept any interference received, including interference that may cause undesired operation.

Note: This equipment has been tested and found to comply with the limits for a Class B digital device, pursuant to part 15 of the FCC Rules. These limits are designed to provide reasonable protection against harmful interference in a residential installation. This equipment generates, uses and can radiate radio frequency energy and, if not installed and used in accordance with the instructions, may cause harmful interference to radio communications. However, there is no guarantee that interference will not occur in a particular installation. If this equipment does cause harmful interference to radio or television reception, which can be determined by turning the equipment off and on, the user is encouraged to try to correct the interference by one or more of the following measures:

- Reorient or relocate the receiving antenna.
- Increase the separation between the equipment and receiver.
- Connect the equipment into an outlet on a circuit different from that to which the receiver is connected.
- Consult the dealer or an experienced radio/TV technician for help.

Modifications not expressly approved by the manufacturer could void the user's authority to operate the equipment under FCC rules.

# 1032B Operating Manual

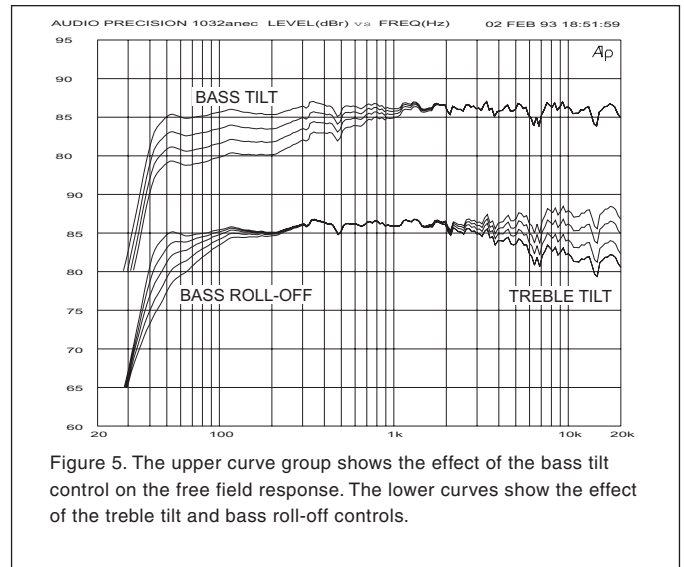
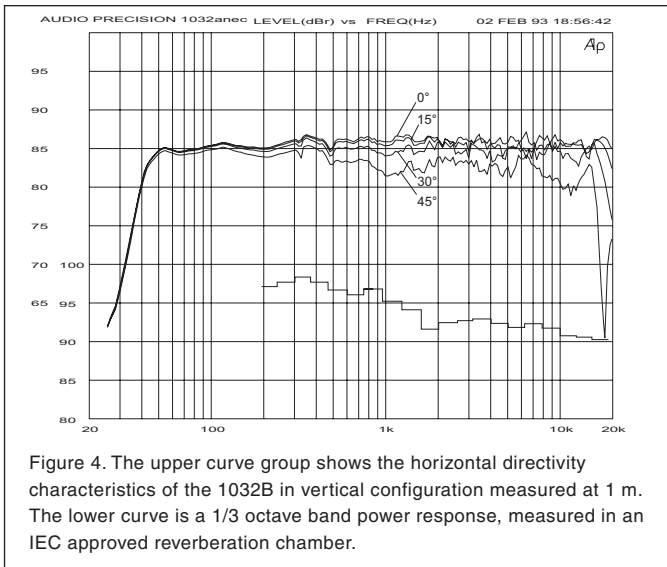

## SYSTEM SPECIFICATIONS

Lower cut-off frequency, -3 dB: ≤40 Hz  
 Upper cut-off frequency, -3 dB: ≥22 kHz

Free field frequency response of system:  
 42 Hz - 21 kHz (±2.5 dB)

Maximum short term sine wave acoustic output on axis in half space, averaged from 100 Hz to 3 kHz:  
 @ 1m > 113 dB SPL  
 @ 0.5m > 119 dB SPL

Maximum long term RMS acoustic output in same conditions with IEC weighted noise (limited by driver unit protection circuit):  
 @ 1m ≥103 dB SPL  
 @ 0.5m ≥109 dB SPL

Maximum peak acoustic output per pair above console bridge, @ 1 m from the listening position with music material: > 124 dB

Self generated noise level in free field @ 1m on axis: < 10 dB (A-weighted)

Harmonic distortion at 90 dB SPL @ 1m on axis:  
 Freq: 50...100 Hz < 1%  
 > 100 Hz < 0.5%

Drivers: Bass 10" (250 mm) cone  
 Treble 1" (25 mm) metal dome  
 Both drivers are magnetically shielded.

Weight: 21,7 kg (48 lb.)  
 Dimensions:  
 Height 495 mm (19 1/2")  
 Width 320 mm (12 5/8")  
 Depth 290 mm (11 7/16")

## CROSSOVER SECTION

Input connector XLR female:  
 pin 1 gnd  
 pin 2 +  
 pin 3 -

Input impedance: 10 kOhm balanced

Input level for 100 dB SPL output @ 1m:  
 variable from +6 to -6 dBu

Input level for maximum short term sine wave output 113 dB SPL @1m:  
 variable from +19 to +7 dBu

Subsonic filter below 40 Hz : 18 dB/octave

Ultrasonic filter above 25 kHz: 12 dB/octave

Crossover frequency, Bass/Treble: 1.8 kHz

Crossover acoustical slopes:  
 24 - 32 dB/octave

Treble tilt control operating range in 2 dB steps:  
 from +2 to -4 dB & MUTE

Bass roll-off control operating range in 2 dB steps:  
 from 0 to -8 dB @ 40 Hz

Bass tilt control operating range in 2 dB steps:  
 from 0 to -8 dB @ 80 Hz & MUTE

The 'CAL' position is with all tone controls set to 'off' and the input sensitivity control to maximum (fully clockwise).

## AMPLIFIER SECTION

Bass amplifier short term output power with a 4 Ohm load: 180 W

Treble amplifier short term output power with an 8 Ohm load: 120 W

Long term output power is limited by driver unit protection circuitry.

Slew rate 80V/μs

Amplifier system distortion at nominal output:

THD	≤ 0.05%
SMPTE-IM	≤ 0.05%
CCIF-IM	≤ 0.05%
DIM 100	≤ 0.05%

Signal to Noise ratio, referred to full output:  
 Bass > 100 dB  
 Treble > 100 dB

Mains voltage: 230, 100/200 or 115/230V according to region

Voltage operating range: ±10%

Power consumption:  
 Idle 20 W  
 Standby <0.5 W  
 Full output 200 W