

Senior Electrol®

Automatic Electric Projection Screen Model



SPECIFICATION DATA

SUGGESTED SPECIFICATIONS: _____ projection screen(s), _____(H) x _____(W), electrically operated 120 volt AC (60 Hz) not more than 2.2 amp. Three wire quick reversal motor to be especially designed for the purpose, to be ball bearing and oiled for life, with automatic thermal overload cutout and integral interlocking gears. To have pre-set but adjustable limit switches to automatically stop screen fabric in the "up" and "down" position. Stop action to be positive to prevent coasting. Rigid metal roller at least 3" in diameter (to be used on screens 12' and under in width), 5¾" in diameter (on screens 14'-18' in width) or 7" in diameter (on screens where either height or width equal or exceed 20'). Roller to be mounted on two heavy duty

brackets equipped with self aligning bearings. Screen surface to be flame retardant and mildew resistant with black masking borders standard. Case to be of wood, with double top for extra rigidity and strength. Motor compartment to be metal lined. Case to be finished with a black primer coat, ready to accept final finish by others. Heavy metal brackets shall be supplied for mounting screen to wall or ceiling. To be complete with 3 position control switch with cover plate. Recessed installation requires access to motor. Screen to be listed by Underwriters' Laboratories and CSA.



Video (NTSC 4:3) Format Dimensions (2" Standard Black Drop At Top)

Viewing Area (H x W)		Nominal Diagonal		Overall Length of Case		Approx. Ship. Wt.	
In.	Cm	In.	Cm	In.	Cm	Lbs.	Kg
50" x 67"	127 x 170	84"	213	93"	236	133	60.3
60" x 80"	152 x 203	100"	254	107"	272	146	66.2
69" x 92"	175 x 234	120"	305	119"	302	156	70.8
87" x 116"	221 x 295	150"	381	143"	363	192	87.1
105" x 140"	267 x 356	180"	457	167"	424	246	111.6
123" x 164"	312 x 417	210"	533	191"	485	343	155.6
141" x 188"	358 x 478	240"	610	215"	546	398	180.5

HDTV (16:9) Format Dimensions (2" Standard Black Drop At Top)

Viewing Area (H x W)		Nominal Diagonal		Overall Length of Case		Approx. Ship. Wt.	
In.	Cm	In.	Cm	In.	Cm	Lbs.	Kg
45" x 80"	114 x 203	92"	234	107"	272	154	69.9
52" x 92"	132 x 234	106"	269	119"	302	162	73.5
54" x 96"	137 x 244	110"	279	123"	312	168	76.2
58" x 104"	147 x 264	119"	302	131"	333	173	78.5
65" x 116"	165 x 295	133"	338	143"	363	188	85.3
78" x 139"	198 x 353	159"	404	167"	424	195	88.5
92" x 164"	234 x 417	188"	478	191"	485	343	155.6
106" x 188"	269 x 478	216"	549	215"	546	384	174.2
119" x 212"	302 x 538	243"	617	239"	607	398	180.5
133" x 236"	338 x 599	271"	688	263"	668	838	380.1

Square Format Dimensions (Screens With ^ Have 2" Standard Black Drop At Top)

Sizes (H x W)		Overall Length of Case		Approx. Ship. Wt.		Sizes (H x W)		Overall Length of Case		Approx. Ship. Wt.	
In.	Cm	In.	Cm	In.	Cm	In.	Cm	In.	Cm	Lbs.	Kg
50" x 50"	127 x 127	73"	185	122	55.2	12' x 12'	366 x 366	167"	424	251	113.9
60" x 60"	152 x 152	83"	211	128	58.1	10' 6" x 14'^^	320 x 427	191"	485	343	155.6
70" x 70"	178 x 178	93"	236	133	60.3	14' x 14'	427 x 427	191"	485	350	158.8
84" x 84"	213 x 213	107"	272	146	66.2	12' x 16'^^	366 x 488	215"	546	384	174.2
6' x 8'^^	183 x 244	119"	302	156	70.8	16' x 16'	488 x 488	215"	546	394	178.7
8' x 8'	244 x 244	119"	302	158	71.7	13' 6" x 18'^^	411 x 549	239"	607	398	180.5
7' x 9'^^	213 x 274	131"	333	173	78.5	18' x 18'	549 x 549	239"	607	411	186.4
9' x 9'^^	274 x 274	131"	333	176	79.8	15' x 20'^^	457 x 610	263"	668	838	380.1
8' x 10'^^	244 x 305	143"	363	192	83.1	20' x 20'	610 x 610	263"	668	858	389.2
10' x 10'^^	305 x 305	143"	363	195	88.5	12' x 24'	366 x 732	311"	790	1011	458.6
9' x 12'^^	274 x 366	167"	424	246	115.6						

PRODUCT NOTES

- **Matte White:** Horizontal seam required when both dimensions exceed 16'.
- **Video Spectra 1.5:** Available in sizes where both height and width do not exceed 8'.
- **High Power®:** Horizontal seam required when both dimensions exceed 8'.
- Overall case length dimensions +/- 1/4" (6 mm).
- Specifications subject to change without notice.
- Detail dimensional drawings, wiring diagrams and installation instructions available upon request.
- Custom formats and sizes available upon request.

WHEN ORDERING, MARK APPROPRIATE SELECTIONS:

- Select viewing surface (All Da-Lite surfaces are GREENGUARD GOLD Certified):
 - Matte White
 - Video Spectra 1.5
 - High Power®
2. Optional accessories:
 - Extra Drop available to lower picture area more than normal. Specify total drop at top ____ (black or white) or at bottom ____ (black or white). 20' maximum total surface height including picture area, except 12x24, where no extra drop is available.
 - No borders (Black masking borders standard).
 - Wireless Remote Control for LVC.
 - Radio Frequency Remote.
 - Radio Frequency Range Extender available.
 - Infrared Remote.
 - Single Motor Low Voltage Control (LVC) - external.
 - Key Locking Cover Plate for 120 V or LVC switch.
 - Key Operated Switch for 120 V only (NOTE: Cannot be used with LVC).
 - 220 Volt (50 Hz) motor.
 - Video Projector Interface Control - external.
 - External SCB-100 - RS-232 Serial Control Board.
 - NET-100 Ethernet-Serial Adapter.
 - White box (black standard).

PRODUCT VIEWS

For Screens Up To 18' X 18':

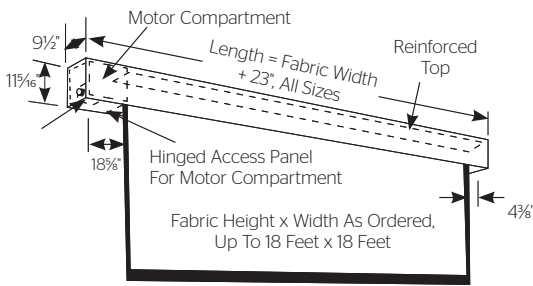

For Screens 20' And Larger In Height Or Width:

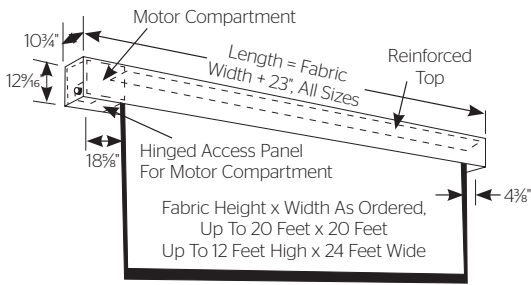

A Milestone AV Technologies Brand

3100 North Detroit Street
 Warsaw, Indiana 46582
 P: 574.267.8101 or 800.622.3737
 F: 574.267.7804 or 877.325.4832
 E: info@da-lite.com
 www.da-lite.com

DL-0207 12.13

© 2013 Milestone AV Technologies LLC. Printed in U.S.A.

SUGGESTED METHOD OF INSTALLATION

Wall Or Ceiling Mount With Hangers

Wall type hangers and ceiling type hangers are standard equipment. One set is supplied with each screen. Useful for recessed installations.

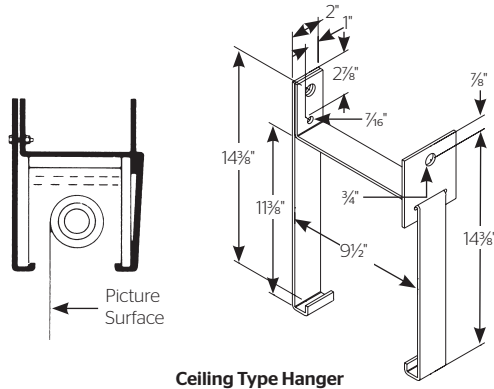

Ceiling Type Hanger

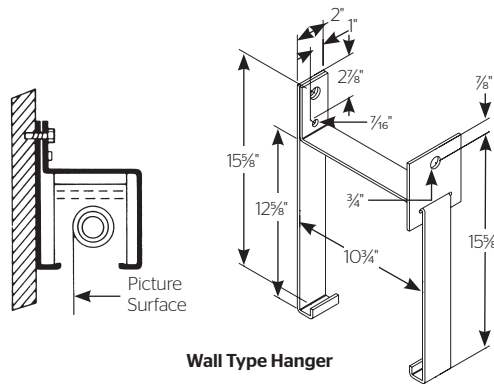

Wall Type Hanger

Recessed Above Ceiling

Other methods of installation will suggest themselves in new buildings where it would be an easy matter to provide a recess for the screen to conceal it when not in use.
Do not seal in-allow access.

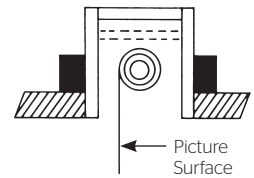

For Exposed Installation

If the screen is to be mounted in an exposed position, it may be covered with finished plywood, veneer, paneling, plastic wall covering or a valance.

Project Name: _____

Architect: _____

Contractor: _____ Phone: _____

Reseller: _____ Phone: _____