



*User's Manual*

# *æro 12A*



Antes de utilizar el equipo, lea la sección "Precauciones de seguridad" de este manual. Conserve este manual para futuras consultas.

Before operating the device, please read the "Safety precautions" section of this manual. Retain this manual for future reference.





### Cajas acústicas activas / Self-powered loudspeaker enclosures

El signo de exclamación dentro de un triángulo indica la existencia de importantes instrucciones de operación y mantenimiento en la documentación que acompaña al producto. Conserve y lea todas estas instrucciones. Siga las advertencias. **ATENCIÓN:** Es un producto clase A, por lo que en entornos domésticos puede causar radio-interferencias, en cuyo caso el usuario tendrá que tomar las medidas oportunas. De acuerdo con EN55103-2, usar el equipo sólo en entornos E1, E2, E3 ó E4.



The exclamation point inside an equilateral triangle is intended to alert the users to the presence of important operating and maintenance (servicing) instructions in the literature accompanying the product.

Heed all warnings. Follow all instructions. Keep these instructions.

**WARNING:** This is a class A product. In a domestic environment this product may cause radio interferences in which case the user may be required to take adequate measures.

Use this product only in E1, E2, E3 or E4 environments according to EN55103-2.

Do not remove mains connector ground, it is dangerous and illegal. Class I device.

No desconecte la tierra en el conector de alimentación pues el peligroso e ilegal. Equipo de Clase I.

El signo del rayo con la punta de flecha, alerta contra la presencia de voltajes peligrosos no aislados. Para reducir el riesgo de choque eléctrico, no retire la cubierta.

Sólo use este equipo con el cable de red de alimentación adecuado para su país.

No instale el aparato cerca de ninguna fuente de calor como radiadores, estufas u otros aparatos que produzcan calor. Debe instalarse siempre sin bloquear la libre circulación de aire por las aletas del radiador.



The lightning and arrowhead symbol warns about the presence of uninsulated dangerous voltage. To reduce the risk of electric shock, do not remove the cover.

Only use this equipment with an appropriate mains cord for your country.

Do not install near any heat sources such as radiators, heat registers, stoves or other apparatus that produce heat.

The circulation of air through the heatsink must not be blocked.

No exponga este equipo a la lluvia o humedad sin el protector de lluvia recomendado. No use este aparato cerca del agua (piscinas y fuentes, por ejemplo). No exponga el equipo a salpicaduras sin el protector de lluvia recomendado, ni coloque sobre él objetos que contengan líquidos, tales como vasos y botellas.

Este símbolo indica que el presente producto no puede ser tratado como residuo doméstico normal, sino que debe entregarse en el correspondiente punto de recogida de equipos eléctricos y electrónicos.



Do not expose this device to rain or moisture without the rain protector supplied. Do not use this apparatus near water (for example, swimming pools and fountains). Do not place any objects containing liquids, such as bottles or glasses, on the top of the unit. Do not splash liquids on the unit without the rain protector supplied.

This symbol on the product indicates that this product should not be treated as household waste. Instead it shall be handed over to the applicable collection point for the recycling of electrical and electronic equipment.

Equipo diseñado para funcionar entre 15°C y 42°C con una humedad relativa máxima del 95%, con un rango de  $\pm 10\%$  de la tensión nominal de alimentación indicada en la etiqueta trasera (según IEC 60065:2001). Si debe sustituir el fusible preste atención al tipo y rango.

El cableado exterior conectado al equipo requiere de su instalación por una persona instruida o el uso de cables flexibles ya preparados.

Si el aparato es conectado permanentemente, la instalación eléctrica del edificio debe incorporar un interruptor multipolar con separación de contacto de al menos 3mm en cada polo.

Desconecte este aparato durante tormentas eléctricas, terremotos o cuando no se vaya a emplear durante largos periodos.

No emplace altavoces en proximidad a equipos sensibles a campos magnéticos, tales como monitores de televisión o material magnético de almacenamiento de datos.



Working temperature ranges from 15°C to 42°C with a relative humidity of 95%, with  $\pm 10\%$  of the rated main voltage value indicated on the rear label (according to IEC 60065:2001). If the fuse needs to be replaced, please pay attention to correct type and ratings.

The outer wiring connected to the device requires installation by an instructed person or the use of a flexible cable already prepared.

If the apparatus is connected permanently, the electrical system of the building must incorporate a multipolar switch with a separation of contact of at least 3mm in each pole.

Unplug this apparatus during lightning storms, earthquakes or when unused for long periods of time.

Do not place loudspeakers in proximity to devices sensitive to magnetic fields such as television monitors or data storage magnetic material.

El colgado del equipo sólo debe realizarse utilizando los herrajes de colgado recomendados y por personal cualificado. No cuelgue la caja de las asas y respete los valores máximos de carga dados en el manual.

No existen partes ajustables por el usuario en el interior de este equipo. Cualquier operación de mantenimiento o reparación debe ser realizada por personal cualificado. Es necesario el servicio técnico cuando el equipo se haya dañado de alguna forma, como que haya caído líquido o algún objeto en el interior del aparato, haya sido expuesto a lluvia o humedad, no funcione correctamente, haya recibido un golpe o su cable de red esté dañado.

Limpie con un paño seco. No use limpiadores con disolventes.

The appliance should be flown only from the rigging points and by qualified personnel. Do not suspend the box from the handles and respect the maximum load values given in the manual.

No user serviceable parts inside. Refer all servicing to qualified service personnel. Servicing is required when the apparatus has been damaged in any way, such as power-supply cord or plug is damaged, liquid has been spilled or objects have fallen into the apparatus, the apparatus has been exposed to rain or moisture, does not operate normally or has been dropped.

Clean only with a dry cloth. Do not use any solvent based cleaners.

## **GARANTÍA**

Todos nuestros productos están garantizados por un periodo de 24 meses desde la fecha de compra.

Las garantías sólo serán válidas si son por un defecto de fabricación y en ningún caso por un uso incorrecto del producto.

Las reparaciones en garantía pueden ser realizadas, exclusivamente, por el fabricante o el servicio de asistencia técnica autorizado.

Otros cargos como portes y seguros, son a cargo del comprador en todos los casos.

Para solicitar reparación en garantía es imprescindible que el producto no haya sido previamente manipulado e incluir una fotocopia de la factura de compra.

## **WARRANTY**

All D.A.S. products are warrantied against any manufacturing defect for a period of 2 years from date of purchase.

The warranty excludes damage from incorrect use of the product.

All warranty repairs must be exclusively undertaken by the factory or any of its authorised service centers.

To claim a warranty repair, do not open or intend to repair the product.

Return the damaged unit, at shippers risk and freight prepaid, to the nearest service center with a copy of the purchase invoice.





## DECLARACIÓN DE CONFORMIDAD DECLARATION OF CONFORMITY

### **D.A.S. Audio, S.A.**

C/ Islas Baleares, 24 - 46988 - Pol. Fuente del Jarro - Valencia. España (Spain).

Declara que la *aero 12A*:

Declares that *aero 12A*:

Cumple con los objetivos esenciales de las Directivas:

Abide by essential objectives relating Directives:

- Directiva de Baja Tensión (Low Voltage Directive) 2006/95/CE
- Directiva de Compatibilidad Electromagnética (EMC) 2004/108/CE
- Directiva RoHS 2002/95/CE
- Directiva RAEE (WEEE) 2002/96/CE

Y es conforme a las siguientes Normas Armonizadas Europeas:

In accordance with Harmonized European Norms:

- EN 60065:2002 Audio, video and similar electronic apparatus. Safety requirements.
- EN 55103-1:1996 Electromagnetic compatibility. Product family standard for audio, video, audio-visual and entertainment lighting control apparatus for professional use. Part 1:Emission.
- EN 55103-2:1996 Electromagnetic compatibility. Product family standard for audio, video, audio-visual and entertainment lighting control apparatus for professional use. Part 2:Immunity.



## CONTENTS

<b>SYSTEM DESCRIPTION</b>	<b>3</b>
<b>LINE DRAWINGS</b>	<b>3</b>
<b>AMPLIFIER DESCRIPTION</b>	<b>4</b>
Preliminary	
ON / OFF	
Overload indicator	
Overheating	
Equalisation	
Low mains voltage	
Current consumption	
Connections	
Troubleshooting	
<b>BLOCK DIAGRAM</b>	<b>8</b>
<b>SPECIFICATIONS</b>	<b>8</b>
<b>RIGGING SYSTEM</b>	<b>9</b>
Warning	
Description	
<b>CONFIGURATIONS</b>	<b>14</b>
<b>APPENDIX</b>	<b>16</b>
Line connections: unbalanced and balanced	



## SYSTEM DESCRIPTION

The **æro 12A** compact line array system joins the **æro series**<sup>®</sup> family of professional sound touring products.

The system incorporates an impressive battery of high tech features that take compact line array systems to an unprecedented level of performance. The latest in Class D power amplification, digital processing and optimized D.A.S. components have been combined with enclosures designed for rapid deployment, precise coverage and high acoustic output.

The **æro 12A** incorporates a D.A.S. **12LN4C**, 12" low frequency transducer. The transducer employs a 75 mm (3") voice coil and neodymium magnet motor assembly. Effective heat evacuation is achieved by way of the Total Air Flux (TAF) cooling scheme which permits high power handling and low power compression.

High frequency reproduction relies on the exceptional characteristics of the new D.A.S. **M-75N** neodymium compression driver designed for use in applications where high SPL and low distortion are required. A pure titanium diaphragm featuring a 75 mm (3") copper-clad, aluminium flat-wire voice coil yields high sensitivity, low distortion and extended frequency response. Each motor system has a copper shorting ring surrounding the pole piece which effectively reduces eddy current induced distortion with the added benefit of increasing the very high frequency output by reducing the inductive rise of the voice coil. The driver is attached to a new **BPS-9010** aluminium waveguide-horn assembly.

The **PL-12S** (steel stacking dolly), **AX-æro12S2** (rigging bumper) and **AXS-æro12** (stacking bracket) accessories allow for any type of stacked or flown of the **æro 12A** system. The **AX-Combo12** allow the **æro 12A** to be flown below other **æro series** products.

The easily portable and rugged enclosure is manufactured using Birch plywood and finished with a durable black paint. The **æro12A's** trapezoidal shape and rear located splay angle adjusters keep the front spacing between adjacent elements the same, providing the array with a "seamless" front baffle, for improved array performance. The captive rigging system splay angles range from 0° to 10° and can be adjusted in 0.5° increments from 0° to 3°, and 1° increments from 3° to 10° allowing a wide range of column curvatures to be accomplished.

The two-way amplifier design of the **æro 12A** sets a new industry benchmark in audio performance, efficiency and power density. This is made possible by employing 3rd generation Class D technologies which have significantly improved three key parameters, audio performance, efficiency and weight.

The 600W amplifier provides extended bandwidth, improved dynamic range and exceptionally low distortion. Impressively compact in size and light in weight, its high power density of over 20W per cubic inch promotes an amplifier design that requires much less space, reducing the overall cabinet size and in turn, the total cabinet weight-an important attribute for flown systems. The high efficiency of the **æro 12A** amplifier ensures cool operation so that no fans or bulky heatsinks are needed.

Signal processing is accomplished by way of a powerful 24 bit DSP providing unparalleled control over critical signal parameters. Digital Finite Impulse Response (FIR) filters are used in the signal processing of the **æro 12A**. Using powerful Wavelet analysis to provide an accurate time-frequency representation combined with precise adjustment of the FIR filters, D.A.S. engineers are able to achieve perfect time alignment.

The **æro 12A** system is protected by two types of limiters-an instantaneous peak limiter to safeguard the systems against spikes and a sonically transparent RMS limiter that controls excessive overpowering and thermal damage to components. This combination provides comprehensive protection for both the speaker components and signal electronics.

## LINE DRAWING

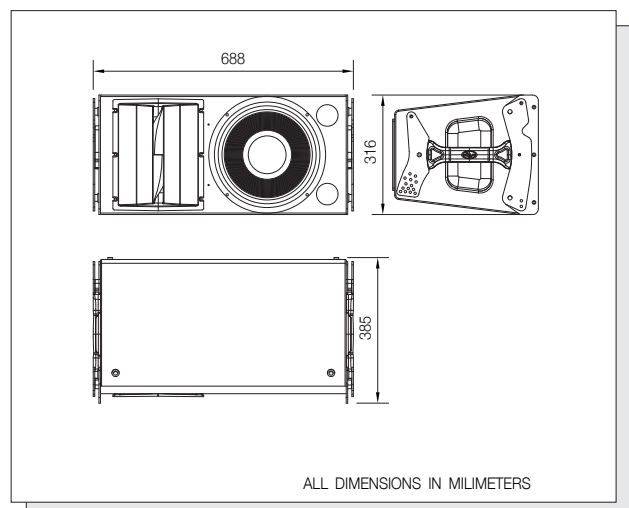

## AMPLIFIER DESCRIPTION

### 1) INPUT :

1/4" Jack+XLR combined socket-type input signal connector. This is a balanced connector just like the LOOP THRU connector with the following pin assignments:

- 1 or S =GND (ground).
- 2 or T =(+) Non inverted input.
- 3 or R =(-) Inverted input.

### 2) LOOP THRU :

XLR-type output signal connector for connecting several units together and sending them all the same signal.

### 3) LIMIT :

Red LED indicates amplifier saturation. Amplifier limiter indicator lights.

### 4) SIGNAL :

Green LED indicates signal presence.

### 5) ON :

Green LED indicates that the unit is ON.

### 6) HF EQ :

Switch for equalisation on high frequency:  
>12 units / Long Throw = HF EQ ON.

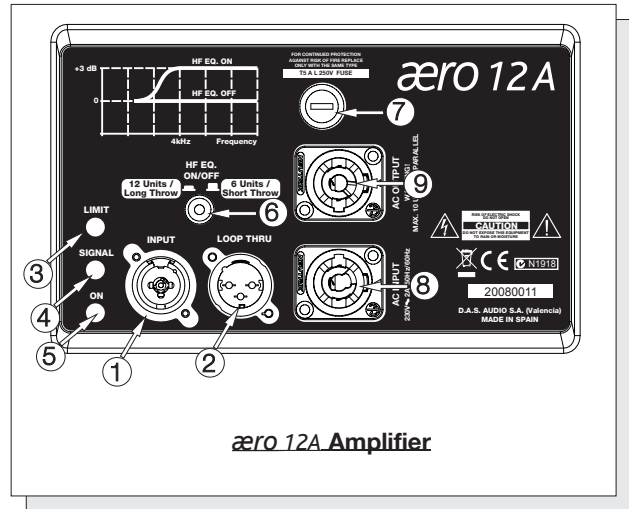

**æro 12A Amplifier**

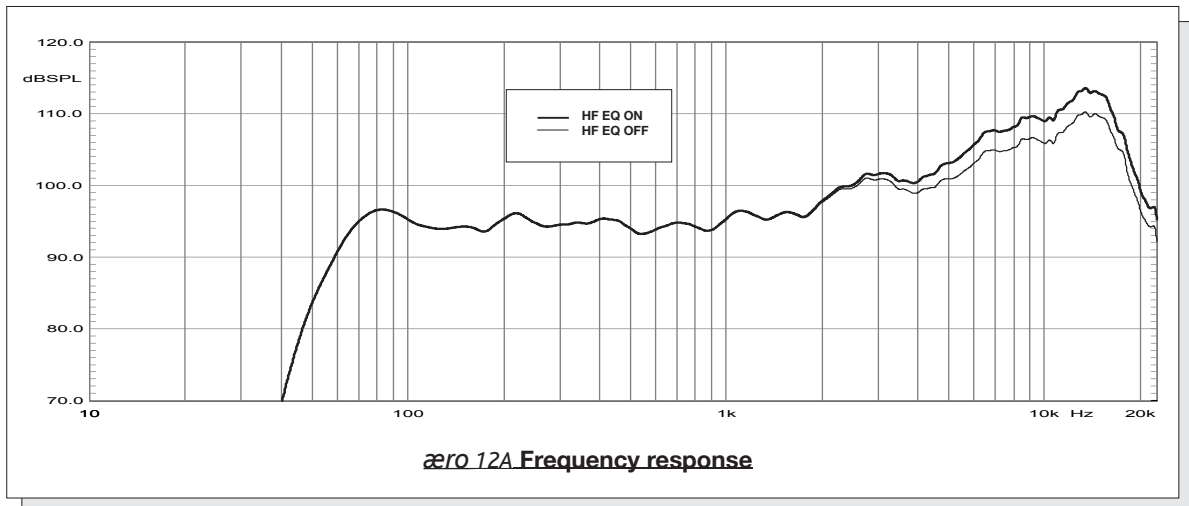

### 7) FUSE :

Fuse holder. Use only the recommended fuse type and size.

### 8) AC INPUT :

Neutrik PowerCon Mains connector for AC cord inlet.

### 9) AC OUTPUT :

Neutrik PowerCon Mains connector for AC cord outlet (Max. 10 units for 230V version. Max. 5 units for 115V version).

### **Preliminary**

This product should only be used in E1, E2, E3 or E4(\*) environments, in accordance with standard EN55103-2 (Electromagnetic compatibility. Product family standard for audio, video, audio-visual and entertainment lighting control apparatus for professional use. Part 2: Immunity.)

Do not cover the amplifier's radiator nor obstruct its ventilation.

For consumption reasons, it is important not to connect the equipment to the same line as the lighting systems, thus avoiding interruptions or sudden drops in lighting intensity.

### **ON/OFF**

A sound system should be switched on sequentially. Switch on the self-powered units last in your sound system (switch on the subwoofer before the mid-high system). Switch on the sound sources such as CD players or turntables, then the mixer, then the processors, and finally the self-powered unit. If you have several units, it is recommended that you switch them on sequentially one at a time.

Follow the inverse order when switching off, turning self-powered units off before any other element in the sound system.

Disconnect the device by removing the mains connector from the mains socket. The mains connector and mains socket must always be freely accessible and never covered or blocked in any way. The mains cable can be detached from the device by disconnecting the Neutrik PowerCon connector. Always disconnect the device by removing the mains connector from the mains socket before detaching the mains cable at the Neutrik PowerCon connector.

**IMPORTANT:** Do not disconnect the unit when it is playing music.

Ensure that the device is disconnected from mains by observing that the ON LED is turned off. Please note that the ON LED can stay on for several seconds after the mains power has been disconnected.

### **Overload indicator**

This device has an indicator (LIMIT LED) that lights when the signal is excessive.

The indicator should not be lit continuously. This distorts the signal (quickly fatiguing your ears) and may damage the speakers. Therefore, it is recommended that you never work with this LED on; at most it should blink only occasionally.

### **Overheating**

This equipment does not normally overheat during normal conditions of use. When overheating occurs, the unit protects itself. You should then find out why and if necessary contact an authorised dealer for Technical Assistance.

Normally it is enough just to let the unit cool down after you have corrected the problem so that the system functions properly again.

### **Equalisation**

The unit does not need extreme settings of equalisation to produce quality sound. Avoid high levels of gain on the equalisers. Gain values above +3 dB on a console's EQ are not recommended.

### **Low mains voltage**

If mains voltage falls below the shutdown voltage for the unit, it will stop playing. When acceptable levels are regained, the unit will switch back on automatically.

The power supply allows the system to function using two voltage ranges: from 90V to 128V, for 115V AC version, and from 180V to 256V, for 230V AC version.

Therefore the current consumed by the first range (90 to 128V) is double the second to achieve the same acoustic power level.

### **Current consumption:**

<b><i>Pink Noise Mains 230 Vrms</i></b>	
Potencia máxima	2A
1/3 Potencia	1.7A
1/8 Potencia	0.95A
Sin carga	0.2A

### **(\*)Note**

- E1.- Residential.
- E2.- Commercial and light industrial.
- E3.- Urban outdoors.
- E4.- Controlled EMC environment and the rural outdoors environment.

## Connections

The *aero 12A* can be used full-range. Full-range use is only recommended for applications where low SPL level and no bass reinforcement is adequate. To use it in this mode simply plug the mixer into the enclosure's input.

The most common use will be combined with the *LX-218A* or *LX-218RA*. In this case different outputs of the mixing console will be used with the *aero 12A* and the SUBs. Both sub systems, *LX-218A* and *LX-218RA* include signal treatment in the amplifiers extending their frequency range up to 85Hz. As well, the amplifier of the *aero 12A* incorporates signal treatment which provides frequency range extension down to 70Hz. Due to this overlap between 70-85Hz the use of an **external delay** to control and adjust the phase of the subs is recommended (with a digital processor, for example).

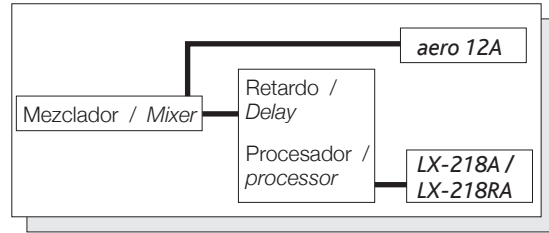

The LOOP THRU connector is an output XLR in parallel with the input connector and is useful for daisy chaining the input signal to a number of boxes, connecting them in parallel.

The number of units that can be linked this way depends on the output impedance of the equipment driving the enclosure, such as the mixer or processor. Typically, to avoid signal degradation, the maximum number that can be daisy chained is given by the formula  $Z_c > 10Z_s$ , where  $Z_c$  is the load impedance and  $Z_s$  is the output impedance of the equipment driving the enclosure (mixer, console, etc). For instance, a mixing console with 100 ohm output impedance allows daisy chaining 20 boxes, when the input impedance of the cabinets is 20K ohm.

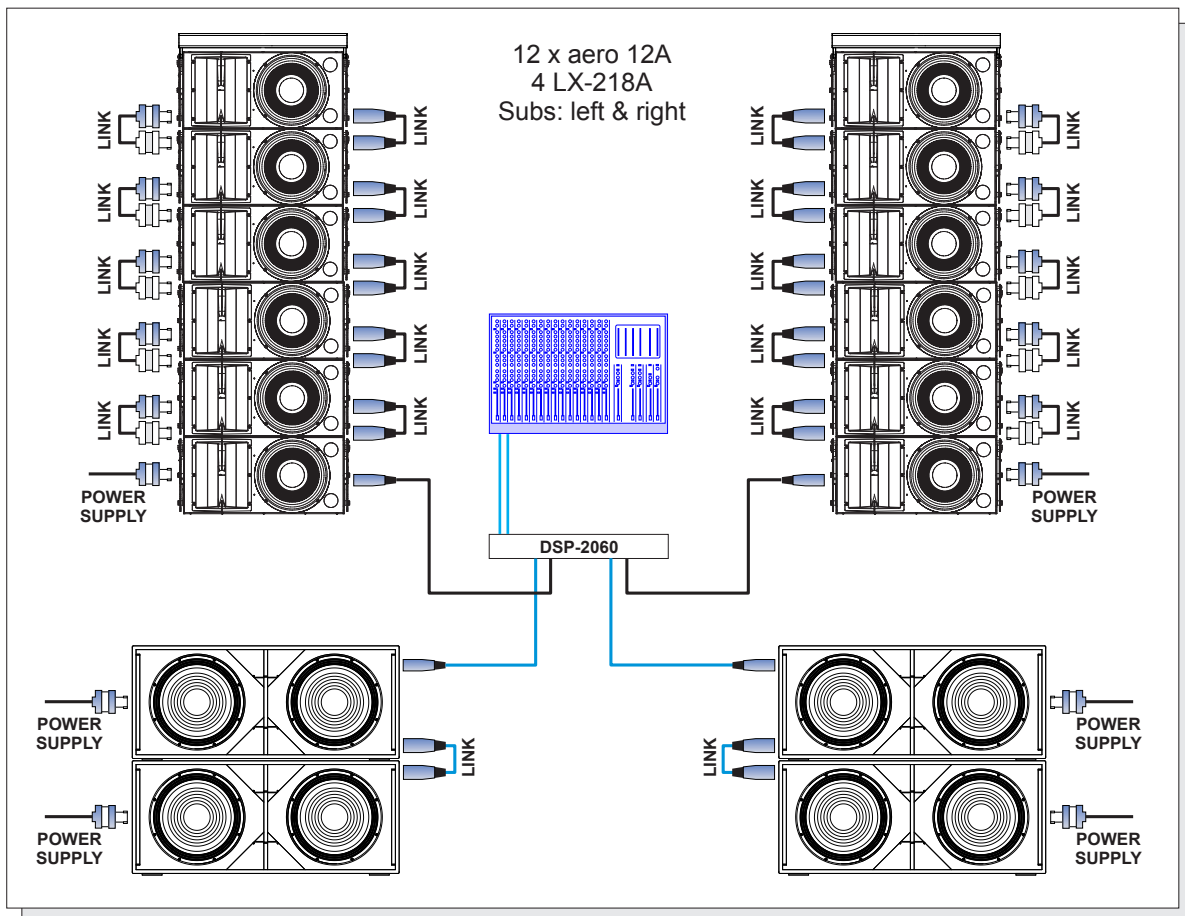

As this diagram illustrates, the control and signal routing to the *aero 12A* and *LX-218RA* is separated for applications where the subwoofer needs to be delayed, driving each enclosure model separately from a processor.



## Troubleshooting

PROBLEM	CAUSE	SOLUTION
No sound from the unit. The SIGNAL LED does not light up.	<p>1 – The signal source is sending no signal.</p> <p>2 – Defective cable.</p> <p>3 - The amplifier has overheated.</p>	<p>1 – Check that the mixer or sound source is sending signal to the UNIT.</p> <p>2 – Check that the cable from the sound source to the UNIT is connected correctly. Replace the cable if defective.</p> <p>3 - Allow the unit to cool down for some minutes and it will function again. Check the main output level of the mixer or channel gains since the unit will have been functioning with excessive levels.</p>
Full power cannot be obtained. The LIMIT LED never lights up.	The signal source does not have a hot enough output.	If using a mixer, use the balanced output if available. Use a professional mixer with a hotter output.
Sound is distorted. The LIMIT LED is not on, or only lights up occasionally.	The mixer or signal source is distorting.	Turn mixer channel gains down. Check that none of your signal sources are distorting.
Sound is distorted and very loud and LIMIT LED lights up.	The system is overloaded and has reached maximum power.	Turn down the mixer's output.
Hum or buzz when a mixer is connected to the unit.	<p>1.– The console probably has un-balanced outputs. You may be using an incorrect un-balanced to balanced cable.</p> <p>2.– The mixer and the powered speaker are not plugged into the same mains outlet.</p> <p>3.– The audio signal cable is too long or too close to an AC cable</p>	<p>1.– Read the appendix of this manual to make a correct un-balanced to balanced cable.</p> <p>2.– Connect the mixer and the unit to the same mains outlet.</p> <p>3.– Use a cable that is as short as possible and/or move the audio signal cable away from mains cables.</p>
Hum or buzz when using lighting controls in the same building.	<p>1.– The audio signal cable is too long or too close to the lighting cable.</p> <p>2.– On a sound system with three-phase AC, the lighting equipment and the UNIT are connected to the same phase.</p>	<p>1.– Move the audio signal cable away from lighting cables. Try to find out at what point the noise is leaking into the system.</p> <p>2.– Connect the sound system to a different phase than the lights. You may need the help of an electrician.</p>
The ON LED does not light up when the mains connector is connected and the unit is switched to ON.	<p>1.– Bad or loose AC connection to the UNIT or the mains outlet.</p> <p>2 – Faulty AC cable.</p> <p>3 – Blown Fuse.</p> <p>4 - The mains voltage is out of range.</p>	<p>1.– Check your connections.</p> <p>2.– Check the cables, connectors and AC power with a suitable mains tester.</p> <p>3.- Replace the blown fuse for another of the same type and size.</p> <p>4.- If the multimeter determines that the mains voltage is out the range, you may need the assistance of an electrician to find an appropriate solution.</p>

## BLOCK DIAGRAM

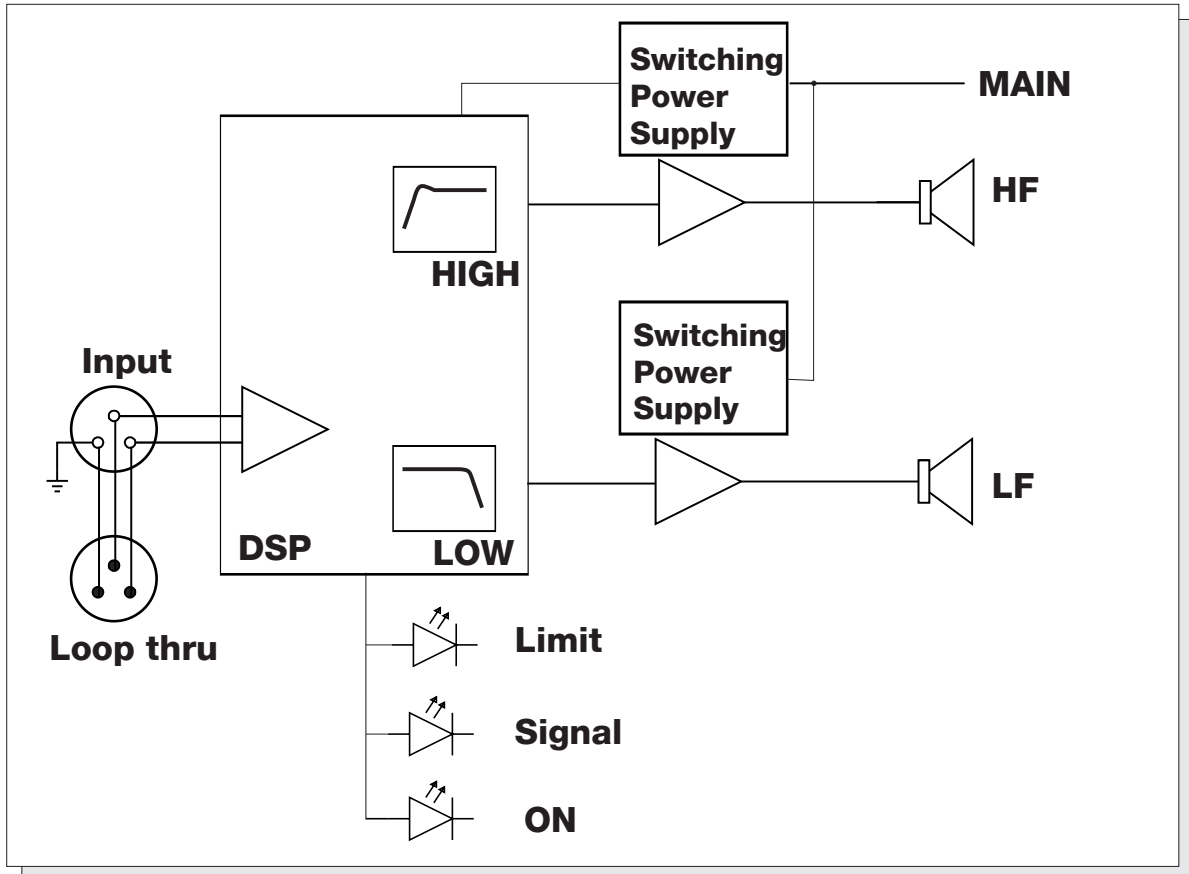

## SPECIFICATIONS

Model	<b>aero 12A</b>	<b>LX-218A</b>	<b>LX-218RA</b>
Nominal LF Power Amplifier	500 W (Class D)	2400 W (Class D)	2400 W (Class D)
Nominal HF Power Amplifier	100 W (Class D)	---	---
Input Type	Balanced Differential Line	Balanced Differential Line	Balanced Differential Line
Input Impedance	Line: 20 kohms	Line: 20 kohms	Line: 20 kohms
Sensitivity	Line: 1.95 V (+8 dBu)	Line: 1.95 V (+8 dBu)	Line: 1.95 V (+8 dBu)
Frequency Range (-10 dB)	63 Hz-20 kHz	28 Hz-100 kHz	28 Hz-100 kHz
Horizontal Coverage (-6dB)	90° Nominal	---	---
Vertical Coverage	Splay Dependent	---	---
Rated Maximum Peak SPL at 1 m <sup>1)</sup>	134 dB	142 dB	142 dB
Transducers/Replacement Parts	LF: 1 x 12LNC4/GM 12P4 HF: 1 x M-75N/GM M-75N	LF: 2 x 18LX/GM 18LX	LF: 2 x 18LX/GM 18LX
Enclosure Geometry	Trapezoidal 7°	Rectangular	Rectangular
Enclosure Material	Birch Plywood	Birch Plywood	Birch Plywood
Color/Finish	Black Paint	Black Paint	Black Paint
Rigging System Splay Angles	Integrated in box design	Ground Stackable	Integrated in box design
Connectors	INPUT: Female XLR LOOP THRU: Male XLR AC INPUT: PowerCon NAC 3 FCA AC OUTPUT: Powercon NAC 3 DFCB	INPUT: Female XLR LOOP THRU: Male XLR AC INPUT: PowerCon NAC 3 FCA AC OUTPUT: Powercon NAC 3 DFCB	INPUT: Female XLR LOOP THRU: Male XLR AC INPUT: PowerCon NAC 3 FCA AC OUTPUT: Powercon NAC 3 DFCB
AC Power Requirements	115 V, 50 Hz/60 Hz 230 V, 50 Hz/60 Hz	Universal Mains, 85 – 230 V (dual voltage)	Universal Mains, 85 – 230 V (dual voltage)
Dimensions (H x W x D)	31.6 x 140 x 60 cm 12.4 x 55 x 23.6 in	55 x 128 x 65 cm (22 x 51 x 26 in)	55 x 135 x 69 cm (22 x 54.1 x 28 in)
Weight	27 kg (59.4 lbs)	84.5 kg (270.5 lbs)	101.5kg (223.3 lbs)
Accessories	AX-aero12 Rigging Grid AX-Combo12 Rigging Adapter KITGS-AX-aero12 PL-12S Steel Stacking Dolly	AX-aero50 Bumper Pick Up Bar for AX-aero50 Bumper AX-Combo12 Rigging Adapter KITW-100 Caster kit KITR-LX218 Rigging hardware kit PL-LX218 Dolly Panel PL-218S Flat Bed Dolly	AX-aero50 Bumper Pick Up Bar for AX-aero50 Bumper AX-Combo12 Rigging Adapter KITW-100 Caster kit PL-LX218 Dolly Panel (included) PL-218S Flat Bed Dolly

(1).- Maximum calculated Peak SPL based on sensitivity and RMS power handling.

## RIGGING SYSTEM

### **Warning**

This manual contains needed information for flying D.A.S. Audio line array systems, description of the elements and safety precautions. To perform any operations related to flying the system, read the present document first, and act on the warnings and advice given. The goal is to allow the user to become familiar with the mechanical elements required to fly the acoustic system, as well as the safety measures to be taken during set-up and teardown.

Only experienced installers with adequate knowledge of the equipment and local safety regulations should fly speaker boxes. It is the user's responsibility to ensure that the systems to be flown (including flying accessories) comply with state and local regulations.

The working load limits in this manual are the results of tests by independent laboratories. It is the user's responsibility to stay within safe limits. It is the user's responsibility to follow and comply with safety factors, resistance values, periodical supervisions and warnings given in this manual. Product improvement by means of research and development is on going at D.A.S. Specifications are subject to change without notice.

To this date, there is no international standard regarding the flying of acoustic systems. However, it is common practice to apply 5:1 safety factors for enclosures and static elements. For slings and elements exposed to material fatigue due to friction and load variation the following ratios must be met; 5:1 for steel cable slings, 4:1 for steel chain slings and 7:1 polyester slings. Thus, an element with a breaking load limit of 1000 kg may be statically loaded with 200 kg (5:1 safety factor) and dynamically loaded with 142 Kg (7:1 safety factor).

When flying a system, the working load must be lower than the resistance of each individual flying point in the enclosure, as well as each box. Hanging hardware should be regularly inspected and suspect units replaced if in doubt. This is important to avoid injury and absolutely no risks should be taken in this respect. It is highly recommended that you implement an inspection and maintenance program on flying elements, including reports to be filled out by the personnel that will carry out the inspections. Local regulations may exist that, in case of accident, may require you to present evidence of inspection reports and corrective actions after defects were found.

Absolutely no risks should be taken with regards to public safety. When flying enclosures from ceiling support structures, extreme care should be taken to assure the load bearing capabilities of the structures so that the installation is absolutely safe. Do not fly enclosures from unsafe structures. Consult a certified professional if needed. All flying accessories that are not supplied by D.A.S. Audio are the user's responsibility. Use at your own risk.

### **Description**

D.A.S. Audio *æro 12A* line array systems, include 2 rigging structures on each side of the box. Manufactured from zinc plated steel they are painted black and are affixed to an internal plate with special crop resistant screws. Two special stainless steel guides are assembled to each of the structures, allow for stacking or flying of boxes. Splay angles can be changed from 0° to 3° in 0.5° increments and from 3° to 10° in 1° increments.

Details of the silk screen of the **AX-aero12S2** indicating numbered flying points depending on the desired angle, which is predicted by using the **EaseFocus** software. To set the guides, 6 mm quick release safety pins should be used. The first **aero 12A** unit should be fixed in the indicated position.

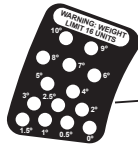
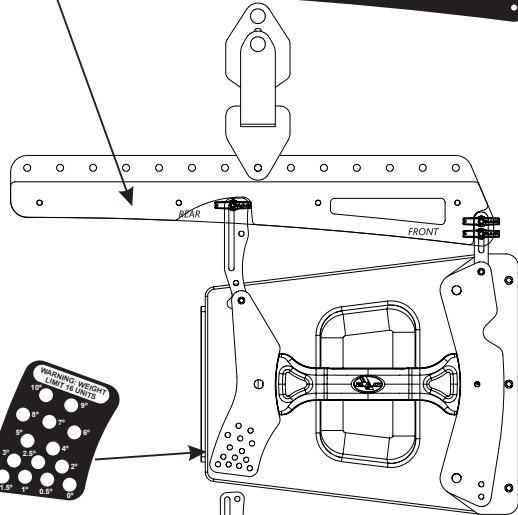

Detail of the silk screen on the **aero 12A** rigging hardware each indicating what angle is obtained, according to the **EaseFocus** software. To set the guides, 6 mm quick release safety pins should be used.

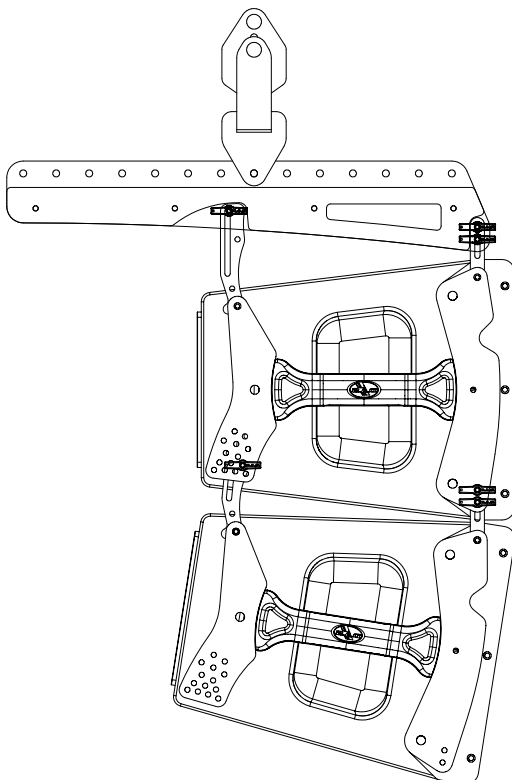
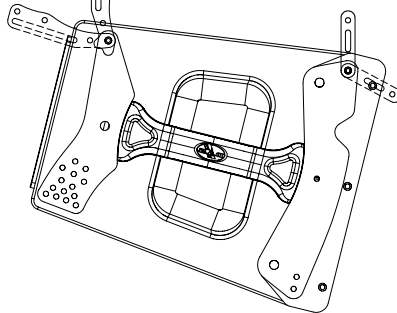

**AX-aero12S2**  
 Weight: 16 kg (35.2 lb).  
 Dimensions (HxWxD): 295 x 749 x 586 (mm.)  
 11.6 x 29.5 x 23.1 (in.).  
 WLL: 460 kgf.

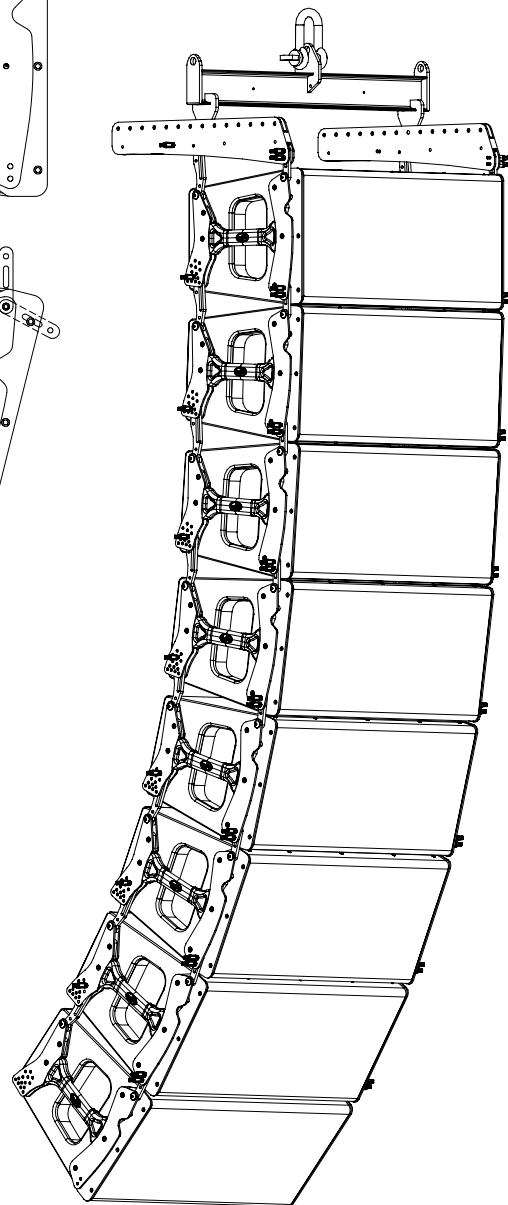

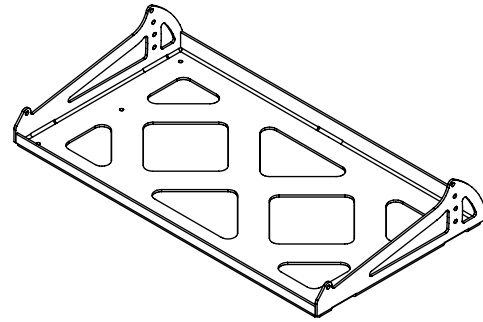
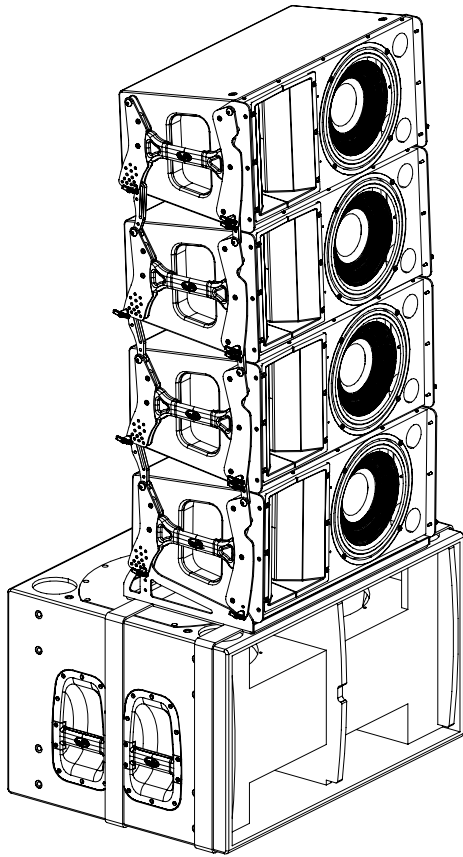

*AXS-aero12*



**(No incluido  
Not included)**

The *AXS-aero12* is used to stack cabinets on a subwoofer box (the endless ratchet strap isn't included, but is necessary for stacking use).

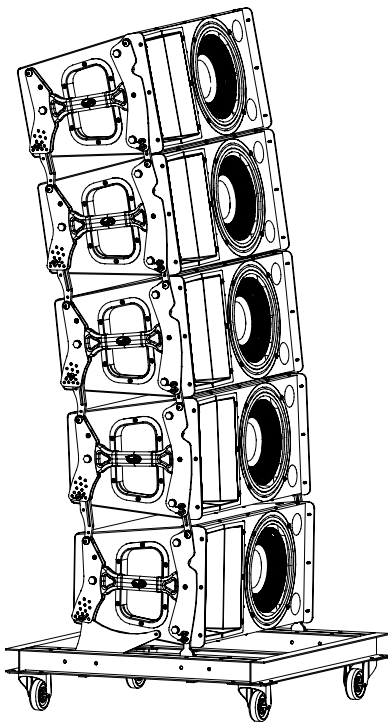

***PL-12S***

Weight: 19,5 kg.

Dimensions (HxWxD): 276 x 760 x 742 (mm.).  
10.87 x 30 x 29.2 (in.).

WLL: 180 kgf.

The *PL-12S* can be used to stack and transport the enclosures as shown in the diagram.

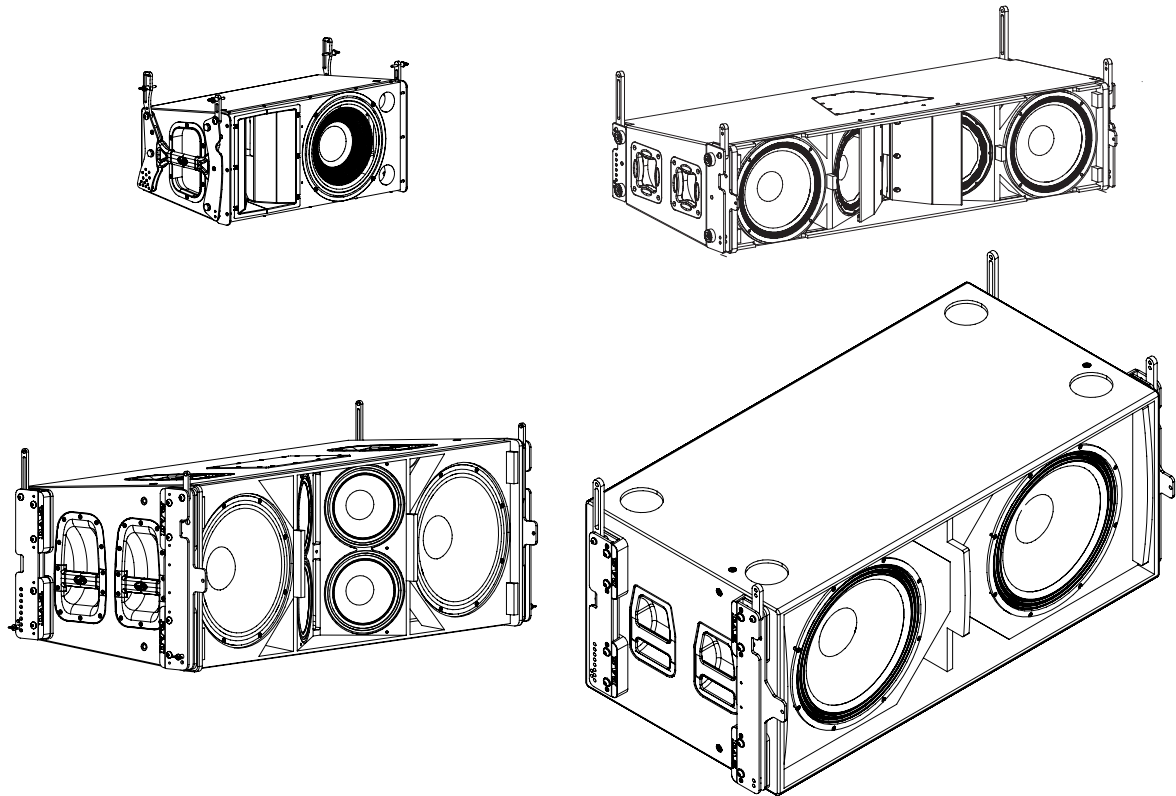

**Diagram of the guides in the rigging hardware of the *aero 12A*, *aero 38*, *aero 38A*, *aero 50*, *LX-218R* and *LX-218RA*.**

**AX-Combo12**

Weight: 19.6 kg (43.12 lb).

Dimensions (HxWxD): 72 x 1350 x 580 (mm).  
2.83 x 53.15 x 22.83 (in.).

WLL: 170 kgf.

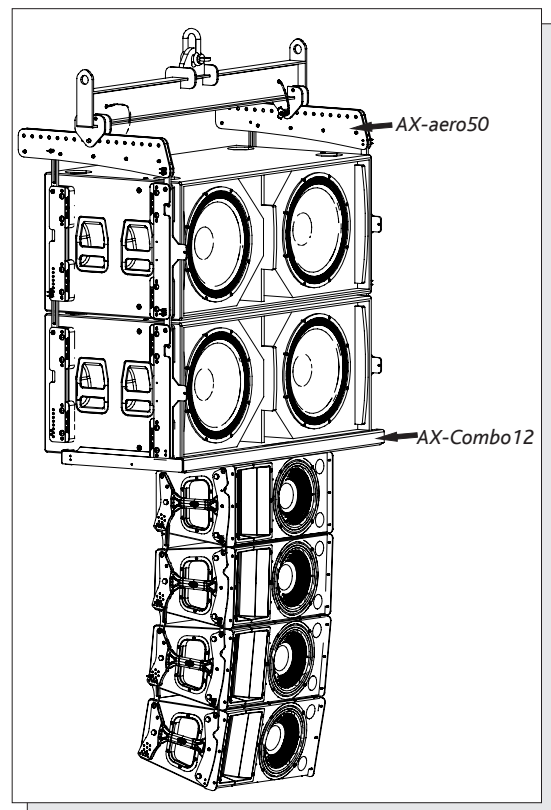
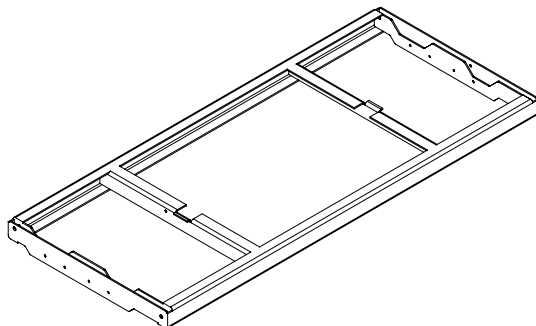

**By way of the AX-Combo12 adapter, the *aero 12A* and *LX-218RA* can be flown together.**

Note: Information about the *AX-aero 50* can be found at [www.dasaudio.com](http://www.dasaudio.com).

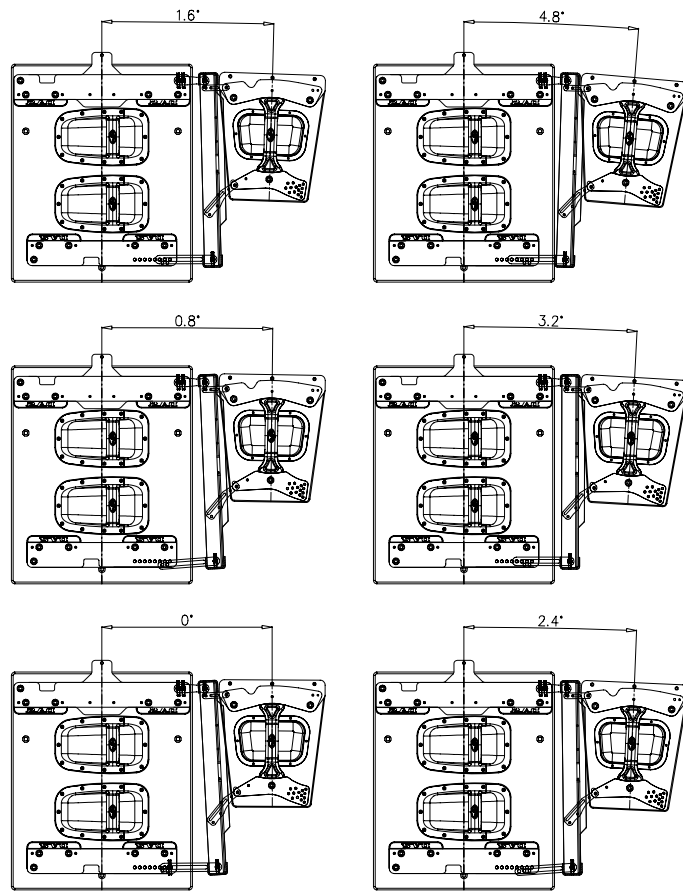

**Splay angles using the AX-Combo12, aero 12A and LX-218RA.**







**CONFIGURATION: 2**

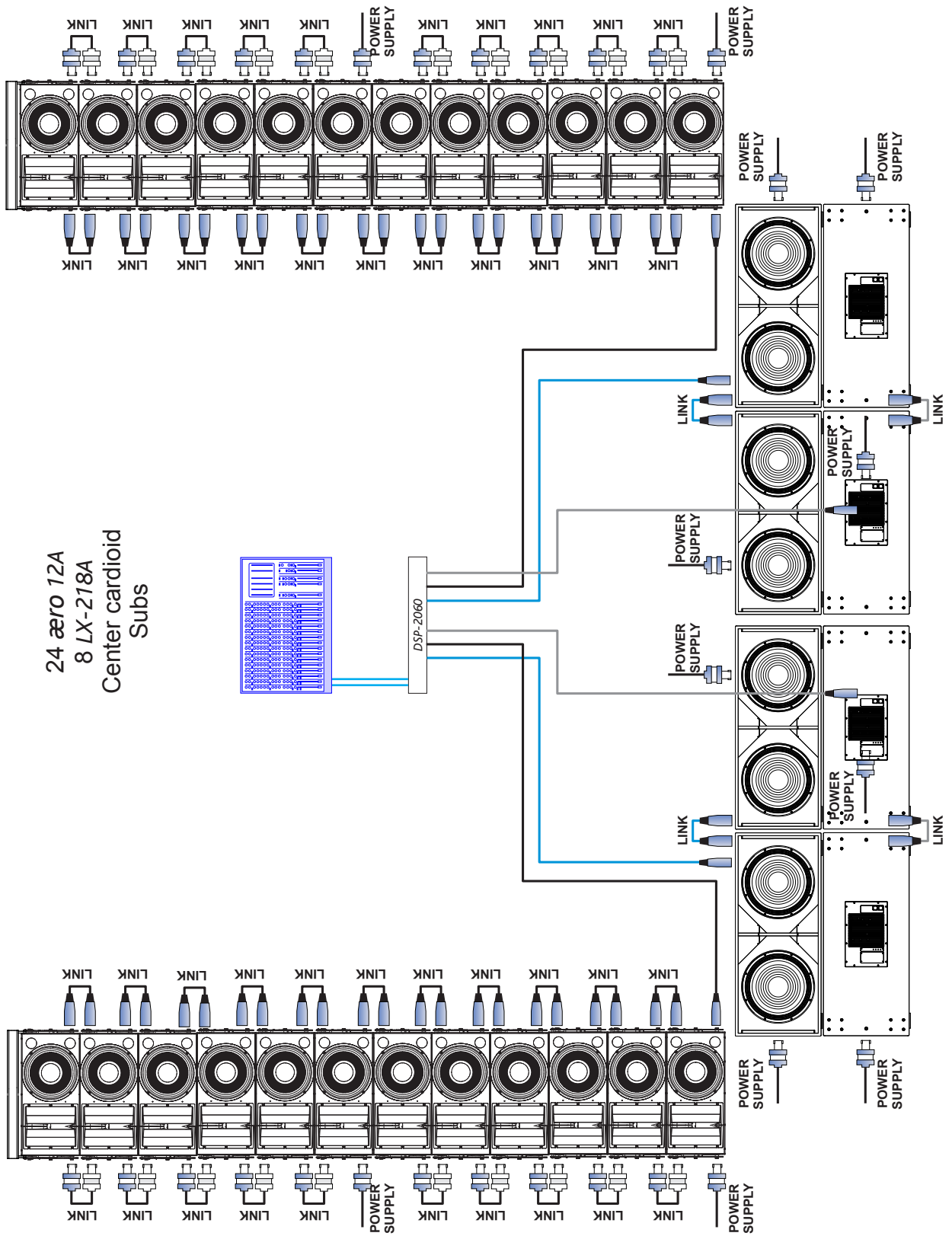

## APPENDIX: Line connections: unbalanced and balanced

There are two basic ways to transport an audio signal with microphone or line level:

**Unbalanced line:** Utilising a two conductor cable, it transports the signal as the voltage between them. Electromagnetic interference can get added to the signal as undesired noise. Connectors that carry unbalanced signals have two pins, such as RCA (Phono) and 1/4" (6.35mm, often referred to as jack) mono. 3 pin connector such as XLR (Cannon) may also carry unbalanced signals if one of the pins is unused.

**Balanced line:** Utilising a three conductor cable, one of them acts as a shield against electromagnetic noise and is the ground conductor. The other two have the same voltage with respect to the ground conductor but with opposite signs. The noise that cannot be rejected by the shield affects both signal conductors in the same way. At the device's input the two signals get summed with opposite sign, so that noise is cancelled out while the programme signal doubles in level. Most professional audio devices use balanced inputs and outputs. Connectors that can carry balanced signal have three pins, such as XLR (Cannon) and 1/4" (6.35mm) stereo.

The graphs that follow show the recommended connection with different types of connectors to balanced processor or amplifier inputs. The connectors on the left-hand side come from a signal source, and the ones on the right hand side go to the inputs of the processor or amplifier. Note that on the unbalanced connectors on the left-hand side, two terminals are joined in side the connector. If hum occurs with balanced connections, try disconnecting the sleeve (ground) on the input connector. Note that the illustrations show what should be connected to what, but that pin locations on an actual XLR connector are different. Also, pin 2 hot is assumed on XLR connectors.

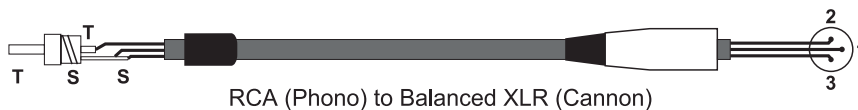
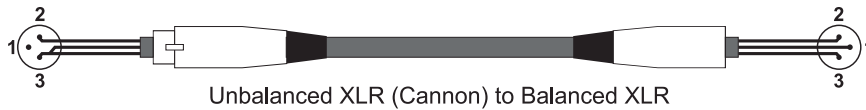



[www.dasaudio.com](http://www.dasaudio.com)



**D.A.S. AUDIO, S.A.**

C/. Islas Baleares, 24  
46988 Fuente del Jarro  
Valencia, SPAIN  
Tel. 96 134 0525  
Tel. Intl. +34 96 134 0860  
Fax 96 134 0607  
Fax Intl. +34 96 134 0607

**D.A.S. AUDIO OF AMERICA, INC.**

Sunset Palmetto Park  
6816 NW 77th Court.  
Miami, FL. 33166 - U.S.A.  
TOLL FREE: 1-888DAS4USA  
Tel. +1 305 436 0521  
Fax +1 305 436 0528

**D.A.S. AUDIO ASIA PTE. LTD.**

25 Kaki Bukit Crescent #01-00/02-00  
Kaki Bukit Techpark 1  
Singapore 416256  
Tel. +65 6742 0151  
Fax +65 6742 0157