

## TECHNICAL SPECIFICATIONS



# ID1.108-66

**Product Group:** iDESIGN Installation Group  
**System Type:** 2-Way, 1" x 8", 60°x60°

## FEATURES & ADVANCES

- Rotatable Waveguide
- 12 Reinforced 3/8-16 threaded hang points
- Omni-mount locations on 4 sides
- U-Bracket factory hardware available
- Combines with other iDESIGN modules to form arrays

## PRODUCT DESCRIPTION

The ID1.108-66 is a 2-way full range loudspeaker designed for permanent installations. This high output foreground module features a direct radiating 8" cone loudspeaker and a 1" exit compression driver mounted to a user rotatable 60°x60° waveguide. By combining iDESIGN modules in pre-engineered arrays, systems can be configured for larger venues.

## MOUNTING & RIGGING

Mounting locations are distributed across 5 surfaces of the enclosure. Omni-mount™ compatible locations are available on 4 sides of the enclosure, while an additional 12 reinforced 3/8-16 threaded locations are available for other mounting options. iDESIGN iDB™ Series array frames are available to facilitate assembly and suspension of multiple modules as a single cluster. iDESIGN iDB™ Series U-bracket hardware is also available for single unit wall and ceiling mount installation.

## CONSTRUCTION

The enclosure is constructed of 12-ply void-free birch hardwood plywood and is coated with a weather and wear resistant ProCoat™ polyurea hybrid finish. All rigging components are weather protected with a heat cured epoxy powder coat finish. Components in the front of the enclosure are protected by a curved grill made from perforated steel that is coated with heat cured epoxy powder, and lined with acoustically transparent foam.

## AMPLIFICATION & PROCESSING

Two channels of discrete amplification and signal processing are required for this module. The preferred signal processors for all iDESIGN products are the McCauley M Series family of digital processing units. The System Design Group can help in creating a complete amplification and signal processing solution.

## APPLICATIONS

- Houses of Worship
- Performing Arts Centers
- Dance Clubs
- Theme Parks
- Auditoriums
- Theatrical Sound Design
- Live Clubs
- Sports Facilities

## PERFORMANCE PARAMETERS

<b>System Type</b>	60°x60°, 2-Way, Full Range
<b>Frequency Response</b>	55Hz - 20kHz
-10dB	60Hz - 18kHz
+/- 3dB	
<b>Sensitivity</b>	96dB @ 2.83V 1 m
Passive	96dB @ 2.83V 1 m
LF	106dB @ 2.83V 1 m
HF	
<b>Maximum SPL</b>	(cont. / peak)
Passive	121dB / 127dB
LF	121dB / 127dB
HF	129dB / 132dB
<b>Crossover Data</b>	1800Hz @ 24dB per octave
<b>Power Ratings</b>	250w @ 8Ω
Passive - AES	200w @ 8Ω
LF - AES	50w @ 16Ω
HF - AES	
Passive - Program	500w @ 8Ω
LF - Program	400w @ 8Ω
HF - Program	100w @ 16Ω

## PHYSICAL PROPERTIES

<b>Weight</b>	31lbs / 14kgs
<b>Dimensions</b>	19.1 H x 10.9 W x 11.5 D x 5.31 T
inches	50.2 H x 27.8 W x 29.2 D x 13.5 T
centimeters	
<b>Enclosure Material</b>	5/8" 12 ply Birch Laminated
<b>Suspension</b>	(12) 3/8-16 reinforced hang points (4) Omni-Mount™ compatible mounting locations (3) Horizontal U-Bracket mounting locations (1) Vertical U-Bracket mounting location
<b>Finish</b>	Procoat™ Polyurea-Hybrid Weatherproofing (Black is standard, White and / or Custom Colors Available)
<b>Transducers</b>	(1) 8" LF Transducer (1) 1.75" Diaphragm, 1" Exit Compression Driver
<b>Connectors</b>	Barrier terminal strip
<b>Compatible Array Frames</b>	IDB.88-AF, IDB.828-AF, IDB.282-AF, IDB.888-AF, (for building clusters) IDB.858-AF
<b>Compatible U-Brackets</b>	IDB.108-H, IDB.108-V (for deploying individually)



## DIMENSIONAL ILLUSTRATIONS

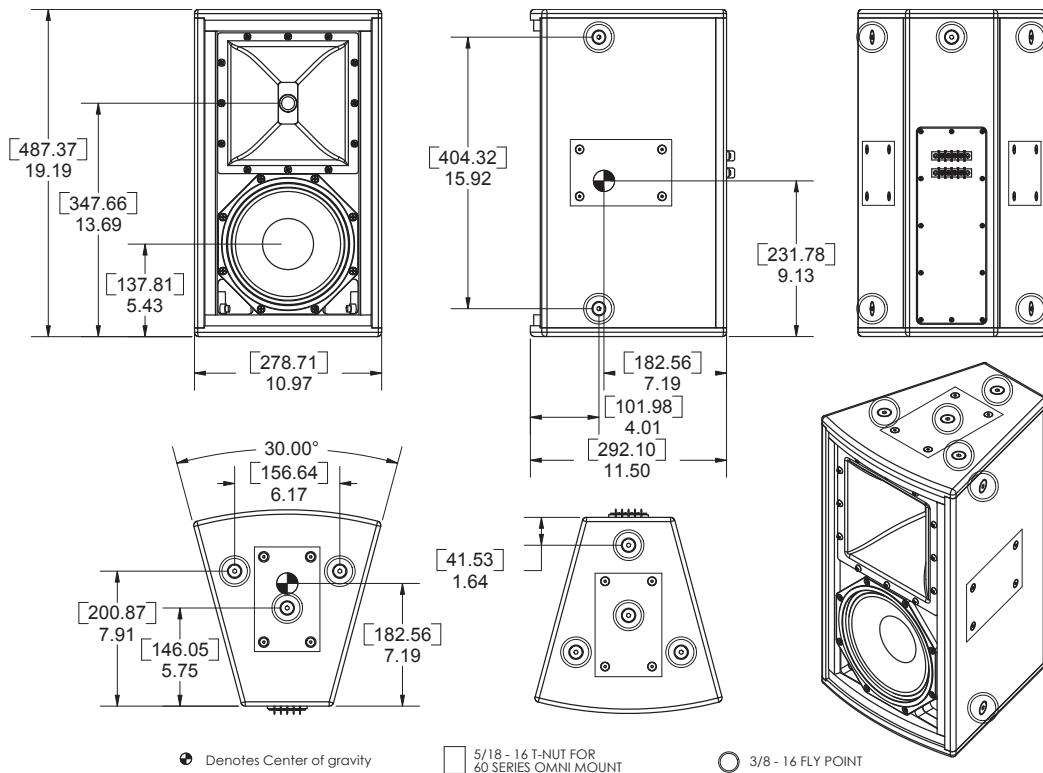

## ARCHITECTS AND ENGINEERS SPECIFICATIONS

The two-way full range loudspeaker system shall incorporate a 2" (51 mm) voice coil, 8" (204 mm) diameter LF transducer and a 1" (25 mm) exit, 1.75" (45 mm) diaphragm compression driver HF transducer. The LF driver shall be mounted in an optimally vented enclosure tuned for maximum low frequency response. The high frequency transducer shall be mounted to a true constant directivity acoustic horn with a nominal horizontal coverage pattern of 60°. The vertical coverage pattern of the horn shall be 60° and shall also provide true constant directivity. The HF horn shall feature a square mounting flange, allowing the horn to be rotated by 90°.

The systems frequency response shall vary no more than  $\pm 3$  dB from 60 Hz to 18 kHz measured on axis. The low frequency transducer shall produce a Sound Pressure Level (SPL) of 96 dB SPL at a distance of 1 meter with an electrical power input of 1 Watt, and shall be capable of producing a maximum peak output of 127 dB SPL on axis at 1 meter. The high frequency transducer shall produce an acoustic Sound Pressure Level (SPL) of 108 dB SPL on axis at 1 meter with an electrical power input of 1 Watt, and shall be capable of producing a peak output of 134 dB SPL on axis at 1 meter.

The low frequency transducer shall handle 200 Watts of amplifier power (per ref Standard AES2-1984-r2003) and shall have a nominal impedance of 8 Ohms. The high frequency transducer shall handle 50 Watts of amplifier power (per AES ref Standard AES2-1984-r2003) and shall have a nominal impedance of 16 Ohms.

The loudspeaker enclosure shall have a maximum weight of 31 lbs.(14.1 kg) and shall measure 10.97" (279 mm) wide at front, 5.31" (134.8 mm) in width at rear, 19.19" (488 mm) in height, and 11.5"(292 mm) in depth. The enclosure sides shall taper at 15° from a maximum frontal width, narrowing to the rear. The structure of the enclosure shall be constructed of 12-ply void-free birch hardwood plywood and shall have a weather and wear resistant ProCoat(tm) polyurea hybrid finish.

Input connectors shall be two, four-terminal barrier strips, wired together in parallel. A total of twelve 3/8"-18 UNC threaded mounting/suspension points (four on top, three on bottom, two per side and one back) shall be provided.

Four additional mounting points shall be provided on the top, bottom, and each side configured to accept an Omnimount brand, Series 60 bracket.

Components in the front of the enclosure are to be protected by a curved grill made from perforated steel that is coated with heat cured epoxy powder, and lined with acoustically transparent foam.

The 2-way full range loudspeaker shall be the McCauley Sound model iD1.108-66.