



User's Manual

LX-218A



Antes de utilizar el equipo, lea la sección "Precauciones de seguridad" de este manual. Conserve este manual para futuras consultas.

Before operating the device, please read the "Safety precautions" section of this manual. Retain this manual for future reference.



Cajas acústicas activas / Self-powered loudspeaker enclosures

El signo de exclamación dentro de un triángulo indica la existencia de importantes instrucciones de operación y mantenimiento en la documentación que acompaña al producto. Conserve y lea todas estas instrucciones. Siga las advertencias. **ATENCIÓN:** Es un producto clase A, por lo que en entornos domésticos puede causar radio-interferencias, en cuyo caso el usuario tendrá que tomar las medidas oportunas. De acuerdo con EN55103-2, usar el equipo sólo en entornos E1, E2, E3 ó E4.



The exclamation point inside an equilateral triangle is intended to alert the users to the presence of important operating and maintenance (servicing) instructions in the literature accompanying the product.

Heed all warnings. Follow all instructions. Keep these instructions.

WARNING: This is a class A product. In a domestic environment this product may cause radio interferences in which case the user may be required to take adequate measures.

Use this product only in E1, E2, E3 or E4 environments according to EN55103-2.

Do not remove mains connector ground, it is dangerous and illegal. Class I device.

No desconecte la tierra en el conector de alimentación pues el peligroso e ilegal. Equipo de Clase I.

El signo del rayo con la punta de flecha, alerta contra la presencia de voltajes peligrosos no aislados. Para reducir el riesgo de choque eléctrico, no retire la cubierta.



The lightning and arrowhead symbol warns about the presence of uninsulated dangerous voltage. To reduce the risk of electric shock, do not remove the cover.

No instale el aparato cerca de ninguna fuente de calor como radiadores, estufas u otros aparatos que produzcan calor. Debe instalarse siempre sin bloquear la libre circulación de aire por las aletas del radiador.

Do not install near any heat sources such as radiators, heat registers, stoves or other apparatus that produce heat.

The circulation of air through the heatsink must not be blocked.

No exponga este equipo a la lluvia o humedad. No use este aparato cerca del agua (piscinas y fuentes, por ejemplo). No exponga el equipo a salpicaduras ni coloque sobre él objetos que contengan líquidos, tales como vasos y botellas. Equipo IP-20.

Do not expose this device to rain or moisture. Do not use this apparatus near water (for example, swimming pools and fountains). Do not place any objects containing liquids, such as bottles or glasses, on the top of the unit. Do not splash liquids on the unit. IP-20 equipment.

Este símbolo indica que el presente producto no puede ser tratado como residuo doméstico normal, sino que debe entregarse en el correspondiente punto de recogida de equipos eléctricos y electrónicos.



This symbol on the product indicates that this product should not be treated as household waste. Instead it shall be handed over to the applicable collection point for the recycling of electrical and electronic equipment.

Equipo diseñado para funcionar entre 15°C y 42°C con una humedad relativa máxima del 95%, con un rango de $\pm 10\%$ de la tensión nominal de alimentación indicada en la etiqueta trasera (según IEC 60065:2001).

Working temperature ranges from 15°C to 42°C with a relative humidity of 95%, with $\pm 10\%$ of the rated main voltage value indicated on the rear label (according to IEC 60065:2001).

El cableado exterior conectado al equipo requiere de su instalación por una persona instruida o el uso de cables flexibles ya preparados.

The outer wiring connected to the device requires installation by an instructed person or the use of a flexible cable already prepared.

Si el aparato es conectado permanentemente, la instalación eléctrica del edificio debe incorporar un interruptor multipolar con separación de contacto de al menos 3mm en cada polo.

If the apparatus is connected permanently, the electrical system of the building must incorporate a multipolar switch with a separation of contact of at least 3mm in each pole.

Desconecte este aparato durante tormentas eléctricas, terremotos o cuando no se vaya a emplear durante largos periodos.

Unplug this apparatus during lightning storms, earthquakes or when unused for long periods of time.

No emplace altavoces en proximidad a equipos sensibles a campos magnéticos, tales como monitores de televisión o material magnético de almacenamiento de datos.



Do not place loudspeakers in proximity to devices sensitive to magnetic fields such as television monitors or data storage magnetic material.

No emplace el producto sobre un carro, base, trípode, soporte o mesa inestables. El dispositivo puede caer, causando serias heridas y dañándose gravemente.

Do not place the product on an unstable cart, stand, tripod, bracket or table. The device may fall, causing serious injury, and serious damage to the device itself.

El colgado del equipo sólo debe realizarse utilizando los herrajes de colgado recomendados y por personal cualificado. No cuelgue la caja de las asas.

The appliance should be flown only from the rigging points and by qualified personnel. Do not suspend the box from the handles.

No existen partes ajustables por el usuario en el interior de este equipo. Cualquier operación de mantenimiento o reparación debe ser realizada por personal cualificado. Es necesario el servicio técnico cuando el equipo se haya dañado de alguna forma, como que haya caído líquido o algún objeto en el interior del aparato, haya sido expuesto a lluvia o humedad, no funcione correctamente, haya recibido un golpe o su cable de red esté dañado.

No user serviceable parts inside. Refer all servicing to qualified service personnel. Servicing is required when the apparatus has been damaged in any way, such as power-supply cord or plug is damaged, liquid has been spilled or objects have fallen into the apparatus, the apparatus has been exposed to rain or moisture, does not operate normally or has been dropped.

Limpie con un paño seco. No use limpiadores con disolventes.

Clean only with a dry cloth. Do not use any solvent based cleaners.

La reventa del producto sólo es posible incluyendo el manual de usuario. Cualquier cambio producido en el producto tiene que ser documentado por escrito y aprobado por el comprador en el momento de la reventa.

Reselling of the product is only possible if the user manual is available. Any changes made to the product have to be documented in writing and passed on to the buyer in the event of resale.

GARANTÍA

Todos nuestros productos están garantizados por un periodo de 24 meses desde la fecha de compra.

Las garantías sólo serán válidas si son por un defecto de fabricación y en ningún caso por un uso incorrecto del producto.

Las reparaciones en garantía pueden ser realizadas, exclusivamente, por el fabricante o el servicio de asistencia técnica autorizado.

Otros cargos como portes y seguros, son a cargo del comprador en todos los casos.

Para solicitar reparación en garantía es imprescindible que el producto no haya sido previamente manipulado e incluir una fotocopia de la factura de compra.

WARRANTY

All D.A.S. products are warrantied against any manufacturing defect for a period of 2 years from date of purchase.

The warranty excludes damage from incorrect use of the product.

All warranty repairs must be exclusively undertaken by the factory or any of its authorised service centers.

To claim a warranty repair, do not open or intend to repair the product.

Return the damaged unit, at shippers risk and freight prepaid, to the nearest service center with a copy of the purchase invoice.



DECLARACIÓN DE CONFORMIDAD DECLARATION OF CONFORMITY

D.A.S. Audio, S.A.

C/ Islas Baleares, 24 - 46988 - Pol. Fuente del Jarro - Valencia. España (Spain).

Declara que *LX-218A*:

Declares that *LX-218A*:

Cumple con los objetivos esenciales de las Directivas:

Abide by essential objectives relating Directives:

- Directiva de Baja Tensión (Low Voltage Directive) 2006/95/CE
- Directiva de Compatibilidad Electromagnética (EMC) 2004/108/CE
- Directiva RoHS 2002/95/CE
- Directiva RAEE (WEEE) 2002/96/CE

Y es conforme a las siguientes Normas Armonizadas Europeas:

In accordance with Harmonized European Norms:

- EN 60065:2002 Audio, video and similar electronic apparatus. Safety requirements.
- EN 55103-1:1996 Electromagnetic compatibility. Product family standard for audio, video, audio-visual and entertainment lighting control apparatus for professional use. Part 1:Emission.
- EN 55103-2:1996 Electromagnetic compatibility. Product family standard for audio, video, audio-visual and entertainment lighting control apparatus for professional use. Part 2:Immunity.

CONTENTS

INTRODUCTION	3
General information	
Features	
AMPLIFIER DESCRIPTION	3
USE	4
Preliminary	
ON / OFF	
Overload indicators	
Overheating	
Equalisation	
Low mains voltage	
CONNECTIONS	5
Self-powered systems connection	
Passive systems connection	
TROUBLESHOOTING	7
BLOCK DIAGRAM	8
LINE DRAWINGS	8
SPECIFICATIONS	9
APPENDIX	10
Line connections: unbalanced and balanced	

EN

INTRODUCTION

General information

Thank you for purchasing **D.A.S. Audio S.A.** products. This unit represents 30 year of expertise in transducer and enclosure design, achieving a system that utilises the most advanced sound reinforcement technology to deliver outstanding audio performance and maximum reliability.

This manual contains the required information to make the best use of the system you have purchased. Please take the time to read it.

Our WEB (www.dasaudio.com) contains further support information such as enclosure and system drawings, data for modelling software, architectural specifications and specification sheets.

Features

This powered subwoofer system is designed to reproduce the low frequencies of the audio spectrum, providing a high level of power.

It comprises two 18" model **18LX** long-excursion loudspeakers with enhanced performance (increased power handling capability and reduced distortion) and optimized design.

The amplifier features an intelligent power supply which detects the mains voltage level and adjusts internal voltages to ensure maximum system efficiency.

Furthermore, the 2400W class D amplifier offers exceptional performance and minimum heat generation.

The digital signal processing (DSP) provides improved control over the input signal treatment.

The "R" version features rigging hardware enabling the systems to be flown simply, safely and efficiently.

AMPLIFIER DESCRIPTION

A) INPUT CLIP:

Red LED indicates and excessive input signal, saturation of the DSP and excessive increases in distortion.

B) LOOP THRU :

XLR-type output signal connector for connecting several units together and sending them all the same signal.

C) INPUT :

XLR-type input signal connector, which just like the LOOP THRU connector, is a balanced connector with the following pins:

1=GND (Ground).

2=(+) Non inverted input.

3=(-) Inverted input.

D) CLIP :

Red LED indicates amplifier saturation, in other words, when it reaches Clip.

E) PROTECTION :

Yellow LED indicates that the protection system has been activated. If the problem that activated the protection is resolved, the amplifier will restart. The problems that can activate the protection system are:

-Mains power out of operating range

-Overheating.

-Overload or short-circuit.

-DC voltage present at the loudspeaker output.

F) SIGNAL :

Green LED indicates signal.

G) POWER :

Green LED indicates ON.

H) Heatsink.

Although the heatsink does not reach high temperatures (during normal use), the heatsink should not be covered or obstructed in any way and it should not be touched.

I) AC INPUT :

Neutrik model PowerCon 'NCA3' connector for connection to the mains supply. This only connects when it is turned and locked and is equipped with a securing tab.

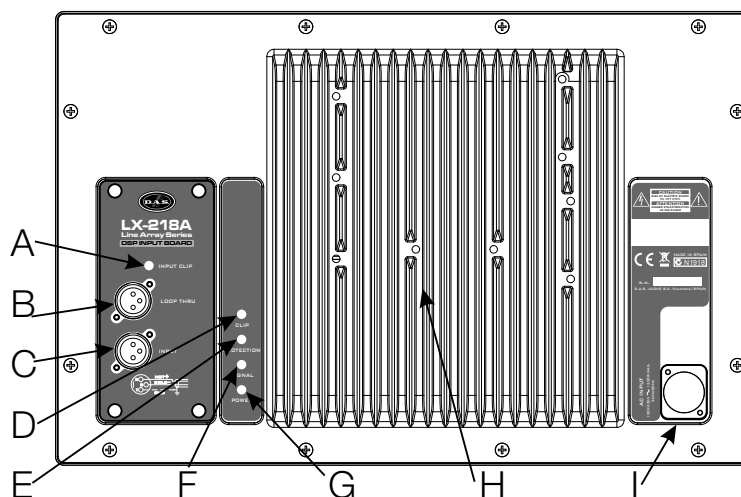

Preliminary

This product should only be used in E1, E2, E3 or E4(*) environments, in accordance with standard EN55103-2 (Electromagnetic compatibility. Product family standard for audio, video, audio-visual and entertainment lighting control apparatus for professional use. Part 2: Immunity.)

Do not cover the amplifier's radiator nor obstruct its ventilation (except for the rain protector supplied by DAS).

For consumption reasons, it is important not to connect the equipment to the same line as the lighting systems, thus avoiding interruptions or sudden drops in lighting intensity.

ON/OFF

A sound system should be switched on sequentially. Switch on the self-powered units last in your sound system (switch on the subwoofer before the mid-high system). Switch on the sound sources such as CD players or turntables, then the mixer, then the processors, and finally the self-powered unit. If you have several units, it is recommended that you switch them on sequentially one at a time.

Follow the inverse order when switching off, turning self-powered units off before any other element in the sound system.

Disconnect the device by removing the mains connector from the mains socket. The mains connector and mains socket must always be freely accessible and never covered or blocked in any way. The mains cable can be detached from the device by disconnecting the Neutrik PowerCon connector. Pull the metal lock back, turn the Neutrik PowerCon counter clockwise to stop and pull the Neutrik PowerCon connector out. Always disconnect the device by removing the mains connector from the mains socket before detaching the mains cable at the Neutrik PowerCon connector.

IMPORTANT: Do not disconnect the Neutrik PowerCon connector during music.

Ensure that the device is disconnected from mains by observing that the lamp marked POWER is turned off. Please note that the POWER lamp can stay on for several seconds after the mains power has been disconnected.

Overload indicators

This device has two indicators (red leds), one for overload input signal and other for the amplifier's clip.

The indicators should not be lit continuously. This distorts the signal (quickly fatiguing your ears) and may damage the speakers. Therefore, it is recommended that you never work with this leds on; at most they should blink only occasionally.

Overheating

This equipment does not normally overheat during normal conditions of use. When overheating occurs, the unit protects itself and the yellow LED 'Protection' lights up. You should then find out why and if necessary contact an authorised dealer for Technical Assistance.

Normally it is enough just to let the unit cool down after you have corrected the problem so that the system functions properly again.

Equalisation

The units does not need extreme settings of equalisation to produce quality sound. Avoid high levels of gain on the equalisers. Gain values above +3 dB on a console's EQ are not recommended.

Low mains voltage

If mains voltage falls below the shutdown voltage for the unit, it will stop playing (the yellow led is on: Protection activated). When acceptable levels are regained, the unit will switch back on automatically (the yellow led is off: Protection deactivated).

The mains supply input can assess the network's voltage level and thus makes the system work in two possible voltage ranges: From 85 Vrms to 130 Vrms; and from 170 Vrms to 260 Vrms.

Therefore, in a country with a nominal mains supply voltage of 120 Vrms, the unit will disconnect when the voltage in the socket goes below 85V or above 130V (both Vrms). Likewise, in a country with a nominal mains supply voltage of 230 Vrms, the unit will disconnect itself when the voltage at the plug goes below 170V or above 260V (both Vrms).

The current draw for 230 V can be seen on the accompanying table. Double the ratings to get the 115V current consumption.

AC input ≈230 Vrms	Pink Noise	Sinusoidal
Max. Power	8A	10.8A
1/3 Power	5.2A	---
1/8 Power	2.4A	---
Idle	0.6A	---

(*)Note

- E1.- Residential.
- E2.- Commercial and light industrial.
- E3.- Urban outdoors.
- E4.- Controlled EMC environment and the rural outdoors environment.

CONNECTIONS

Self-powered systems connection

The illustration below show a typical diagram for connecting this system to other powered units. In this four-way configuration and the sub-bass frequencies are handled by *LX-218A* units while the low, medium and high frequencies are handled by *aero 38A* units. An external processor is required to time-align the sub-bass and low frequencies by adding delays. Additional equalization or filtering are not required.

As can be seen, the *aero 38A* units are connected using the loop thru's on both the mains supply as well as the signal. In the case of the *LX-218A*, only the signal can be looped thru, power must be supplied to each unit independently.

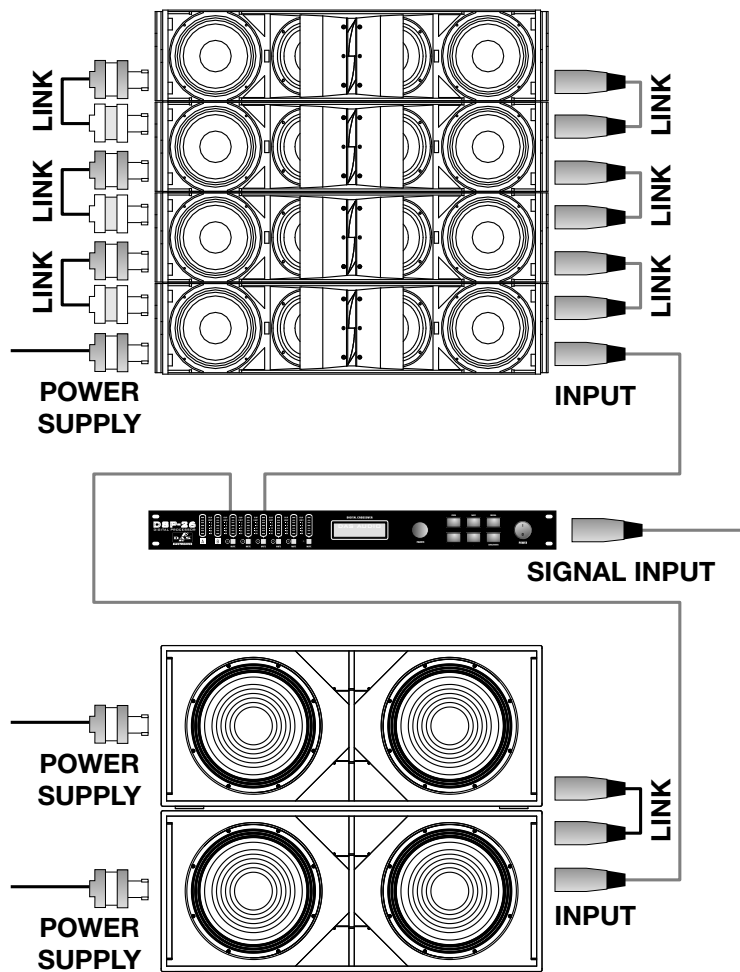

Passive systems connection

In this other four-way configuration, besides introducing delays, the external processor has to process the signal and distribute it amongst the other external amplifiers, with the correct equalization. (Check the factory recommendations for *aero 38* or *aero 48* units.)

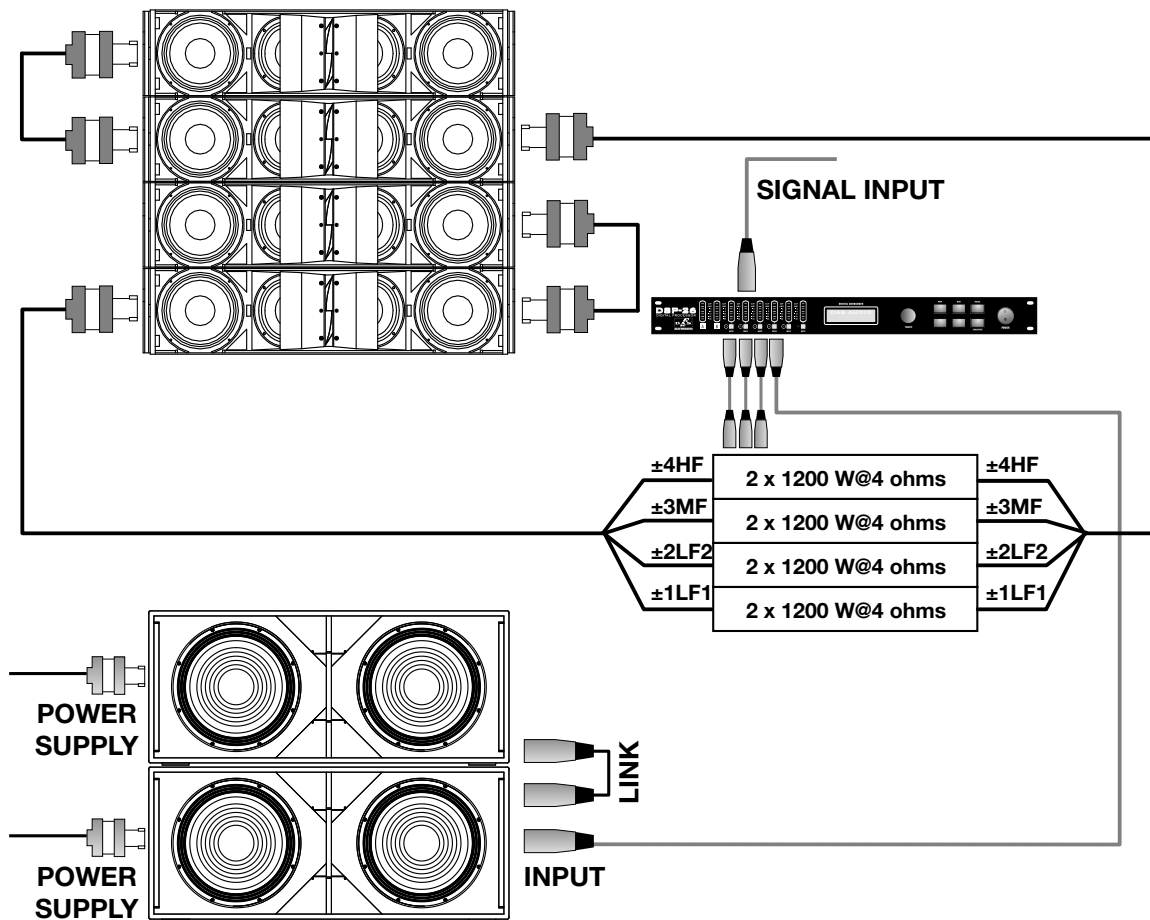

TROUBLESHOOTING

PROBLEM	CAUSE	SOLUTION
No sound from the unit. The SIGNAL presence LED indicator(s) do(es) not light up.	<p>1 – The signal source is sending no signal.</p> <p>2 – Defective cable.</p>	<p>1 – Check that the mixer or sound source is sending signal to the UNIT.</p> <p>2 – Check that the cable from the sound source to the UNIT is connected correctly. Replace the cable if defective.</p>
Full power cannot be obtained. The overload LED indicator(s) never light(s) up.	The signal source does not have a hot enough output.	If using a mixer, use the balanced output if available. Use a professional mixer with a hotter output.
Sound is distorted. The overload LED indicator(s) is/are not on, or only light up occasionally.	The mixer or signal source is distorting.	Turn mixer channel gains down. Check that none of your signal sources are distorting.
Sound is distorted and very loud. One or more overload LED indicators light up.	The system is overloaded and has reached maximum power.	Turn down the mixer's output.
Hum or buzz when a mixer is connected to the unit.	<p>1.– The console probably has un-balanced outputs. You may be using an incorrect un-balanced to balanced cable.</p> <p>2.– The mixer and the powered speaker are not plugged into the same mains outlet.</p> <p>3.– The audio signal cable is too long or too close to an AC cable</p>	<p>1.– Read the appendix of this manual to make a correct un-balanced to balanced cable.</p> <p>2.– Connect the mixer and the unit to the same mains outlet.</p> <p>3.– Use a cable that is as short as possible and/or move the audio signal cable away from mains cables.</p>
Hum or buzz when using lighting controls in the same building.	<p>1.– The audio signal cable is too long or too close to the lighting cable.</p> <p>2.– On a sound system with three-phase AC, the lighting equipment and the UNIT are connected to the same phase.</p>	<p>1.– Move the audio signal cable away from lighting cables. Try to find out at what point the noise is leaking into the system.</p> <p>2.– Connect the sound system to a different phase than the lights. You may need the help of an electrician.</p>
The power on LED indicator(s) do(es) not light up when the power connector is rotated and locked at the ON (LOCK) position.	<p>1.– Bad or loose AC connection to the UNIT or the mains outlet.</p> <p>2 – Faulty AC cable.</p> <p>3 – Blown Fuse.</p>	<p>1.– Check you connections.</p> <p>2.– Check the cables, connectors and AC power with a suitable mains tester.</p> <p>3.- Take the unit to a service centre for replace the blown fuse.</p>
No sound from the unit. The Protection LED indicator is on.	<p>1.- Mains voltage very low or very high.</p> <p>2.- Overheating.</p> <p>3.- Overload or short-circuit.</p> <p>4.- DC at amplifier's output.</p>	<p>1.- Check mains voltage with a suitable mains tester.</p> <p>2.- Check input signal because the level or the EQ are very high.</p> <p>3.- Take the unit to a service centre.</p> <p>4.- Take the unit to a service centre.</p>

BLOCK DIAGRAM

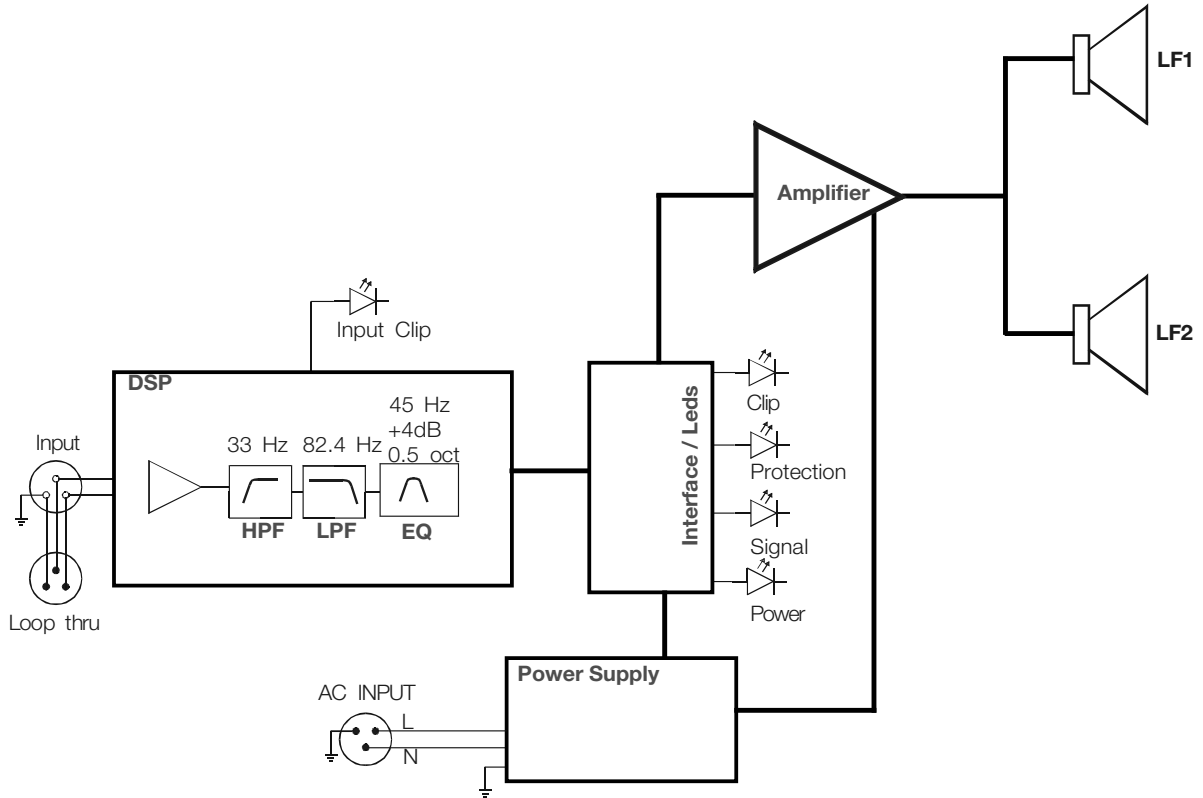

LINE DRAWINGS

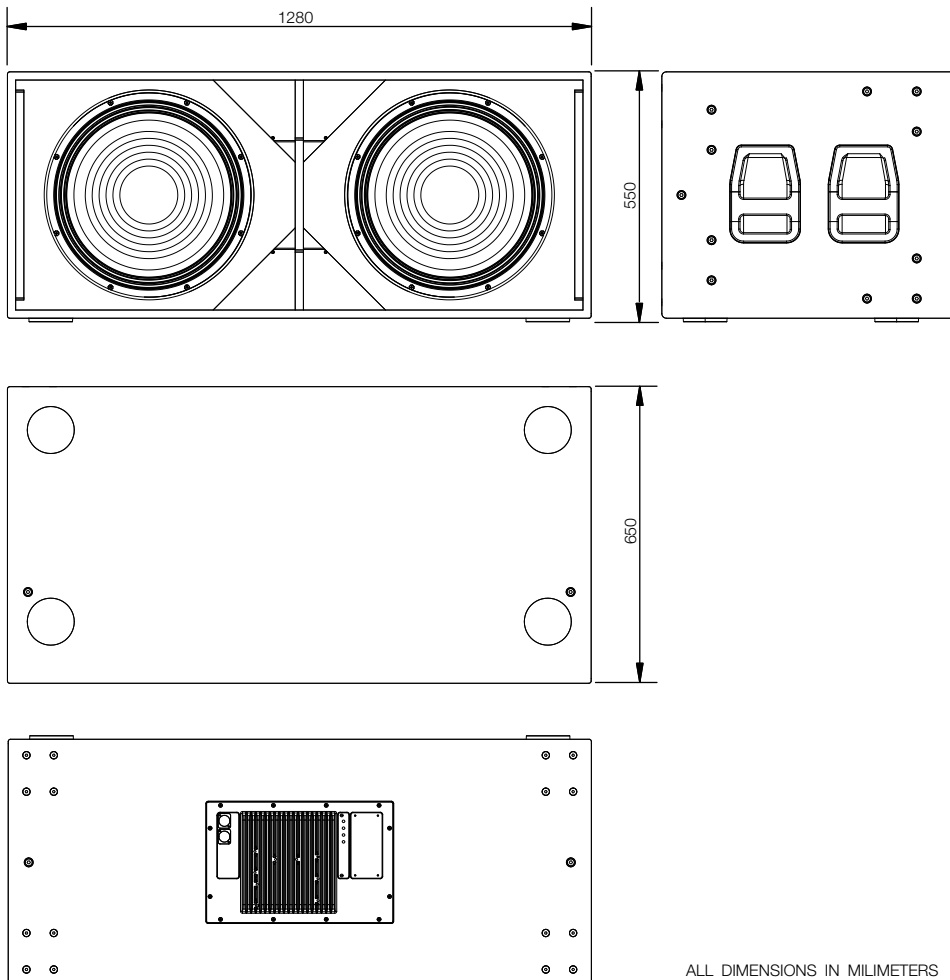

EN

SPECIFICATIONS

<i>LX-218A</i>	
Nominal LF Power Amplifier:	2400 W (Class D)
Input Type:	Balanced Differential Line
Input Impedance:	Line: 20 kohms
Sensitivity:	Line: 1.95 V (+8 dBu)
Frequency Range (-10 dB):	28 Hz-100 Hz
Horizontal Coverage (-6 dB):	---
Vertical Coverage:	---
Rated Maximum Peak SPL at 1 m:	141 dB
Transducers/Replacement Parts:	LF: 2 x <i>18LX</i> /GM <i>18LX</i>
Enclosure Geometry:	Rectangular
Enclosure Material:	Birch Plywood
Color/Finish:	Black Paint
Rigging System:	Ground Stackable (integrated in box design on model <i>LX-218R</i>)
Connectors (DSP input board):	INPUT: Female XLR LOOP THRU: Male XLR AC INPUT: PowerCon NAC 3 FCA
AC Power Requirements:	Universal Mains 85 -230V, 50Hz/60Hz
Dimensions (H x W x D):	55 x 128 x 65 cm 22 x 51 x 26 in
Weight:	73.5 kg (161.7 lbs)
Accessories:	<i>AX-AERO38</i> Bumper <i>AX-AERO48</i> Bumper <i>KITR-LX218</i> Rigging hardware kit <i>KITW-100</i> Caster kit <i>PL-LX218</i> dolly panel <i>PL-218S</i> Dolly platform for vertical stacking

D.A.S. Audio S.A. continuously strives to enhance its products through investigation and development. All specifications are subject to change without prior warning.

Product specifications, detailed technical sheets, as well as information for the use of EASE and other modelling programs are available at www.dasaudio.com .

APPENDIX: Line connections: unbalanced and balanced

There are two basic ways to transport an audio signal with microphone or line level:

Unbalanced line: Utilising a two conductor cable, it transports the signal as the voltage between them. Electromagnetic interference can get added to the signal as undesired noise. Connectors that carry unbalanced signals have two pins, such as RCA (Phono) and 1/4" (6.35mm, often referred to as jack) mono. 3 pin connector such as XLR (Cannon) may also carry unbalanced signals if one of the pins is unused.

Balanced line: Utilising a three conductor cable, one of them acts as a shield against electromagnetic noise and is the ground conductor. The other two have the same voltage with respect to the ground conductor but with opposite signs. The noise that cannot be rejected by the shield affects both signal conductors in the same way. At the device's input the two signals get summed with opposite sign, so that noise is cancelled out while the programme signal doubles in level. Most professional audio devices use balanced inputs and outputs. Connectors that can carry balanced signal have three pins, such as XLR (Cannon) and 1/4" (6.35mm) stereo.

The graphs that follow show the recommended connection with different types of connectors to balanced processor or amplifier inputs. The connectors on the left-hand side come from a signal source, and the ones on the right hand side go to the inputs of the processor or amplifier. Note that on the unbalanced connectors on the left-hand side, two terminals are joined in side the connector. If hum occurs with balanced connections, try disconnecting the sleeve (ground) on the input connector. Note that the illustrations show what should be connected to what, but that pin locations on an actual XLR connector are different. Also, pin 2 hot is assumed on XLR connectors.

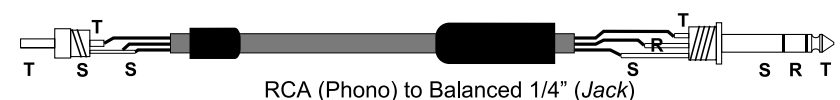
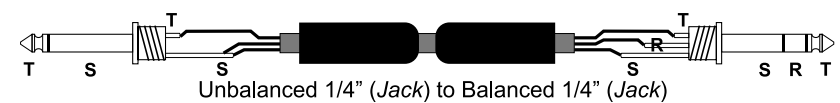
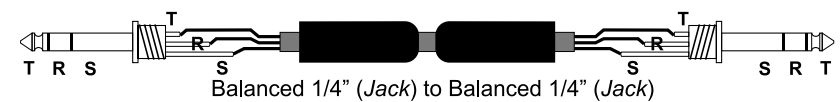
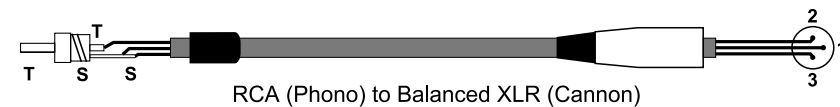
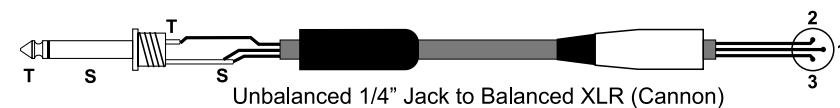
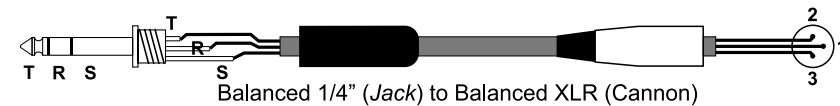
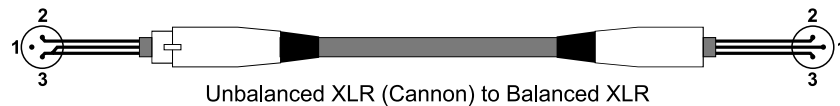
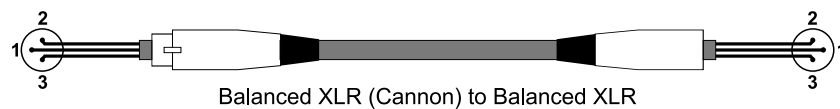

www.dasaudio.com



D.A.S. AUDIO, S.A.

C/. Islas Baleares, 24
46988 Fuente del Jarro
Valencia, SPAIN
Tel. 96 134 0525
Tel. Intl. +34 96 134 0860
Fax 96 134 0607
Fax Intl. +34 96 134 0607

D.A.S. AUDIO OF AMERICA, INC.

Sunset Palmetto Park
6816 NW 77th Court.
Miami, FL. 33166 - U.S.A.
TOLL FREE: 1-888DAS4USA
Tel. +1 305 436 0521
Fax +1 305 436 0528

D.A.S. AUDIO ASIA PTE. LTD.

25 Kaki Bukit Crescent #01-00/02-00
Kaki Bukit Techpark 1
Singapore 416256
Tel. +65 6742 0151
Fax +65 6742 0157