

ALLEN&HEATH



iDR0

iLive Mix System DSP MiniRack

USER GUIDE

Publication AP7129

Limited Two Year Warranty

This product has been manufactured in the UK by ALLEN & HEATH and is warranted to be free from defects in materials or workmanship for a period of two years from the date of purchase by the original owner.

To ensure a high level of performance and reliability for which this equipment has been designed and manufactured, read this User Guide before operating.

In the event of a failure, notify and return the defective unit to ALLEN & HEATH or its authorised agent as soon as possible for repair under warranty subject to the following conditions:

Conditions Of Warranty

1. The equipment has been installed and operated in accordance with the instructions in this User Guide
2. The equipment has not been subject to misuse either intended or accidental, neglect, or alteration other than as described in the User Guide or Service Manual, or approved by ALLEN & HEATH.
3. Any necessary adjustment, alteration or repair has been carried out by ALLEN & HEATH or its authorised agent.
4. The defective unit is to be returned carriage prepaid to ALLEN & HEATH or its authorised agent with proof of purchase.
5. Units returned should be packed to avoid transit damage.

In certain territories the terms may vary. Check with your ALLEN & HEATH agent for any additional warranty, which may apply.

 This product complies with the European Electromagnetic Compatibility directives 89/336/EEC & 92/31/EEC and the European Low Voltage Directives 73/23/EEC & 93/68/EEC.

Any changes or modifications to the power supply unit not approved by Allen & Heath could void the compliance of the product and therefore the users authority to operate it.

iDR0 User Guide AP7129 Issue 1.

Copyright © 2008 Allen & Heath. All rights reserved

ALLEN&HEATH

Manufactured in the United Kingdom by Allen & Heath Limited
Kernick Industrial Estate, Penryn, Cornwall, TR10 9LU, UK

<http://www.allen-heath.com>

WARNINGS - Read the following before proceeding :

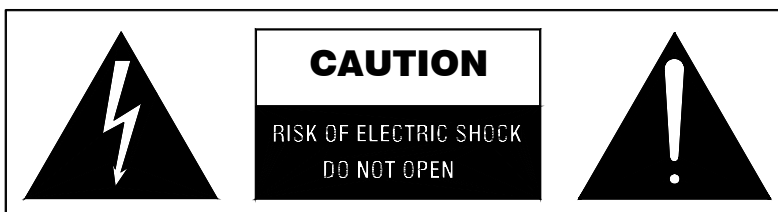

ATTENTION: RISQUE DE CHOC ELECTRIQUE – NE PAS OUVRIR

- Read instructions:** Retain these safety and operating instructions for future reference. Adhere to all warnings printed here and on the equipment. Follow the operating instructions printed in this User Guide.
- Do not remove covers:** Operate the equipment with its covers correctly fitted. Refer any service work on the equipment to competent technical personnel only.
- Power sources:** Connect the equipment to a mains power supply only of the type described in this User Guide and marked on the rear panel. Use only the power cord with sealed mains plug appropriate for your local mains supply as provided with the equipment. If the provided plug does not fit into your outlet consult your service agent for assistance.
- Power cord routing:** Route the power cord so that it is not likely to be walked on, stretched or pinched by items placed upon or against it.
- Grounding:** Do not defeat the grounding and polarisation means of the power cord plug. Do not remove or tamper with the ground connection in the power cord.



WARNING: This equipment must be earthed.

- Water and moisture:** To reduce the risk of fire or electric shock do not expose the equipment to rain or moisture or use it in damp or wet conditions. Do not place containers of liquid on it which might spill into any openings.
- Ventilation:** Do not obstruct the ventilation slots or position the equipment where the air flow required for ventilation is impeded. If the equipment is to be operated in a flightcase ensure that it is constructed to allow adequate ventilation.
- Heat and vibration:** Do not locate the equipment in a place subject to excessive heat or direct sunlight as this could be a fire hazard. Locate the equipment away from any devices which produce heat or cause excessive vibration.
- Servicing:** Switch off the equipment and unplug the power cord immediately if it is exposed to moisture, spilled liquid, objects fallen into the openings, the power cord or plug become damaged, during lightening storms, or if smoke, odour or noise is noticed. Refer servicing to qualified technical personnel only.
- Installation:** Install the equipment in accordance with the instructions printed in this User Guide. Use the equipment connections for their intended purpose only.



Important Mains plug wiring instructions.

The unit is supplied with a moulded mains plug fitted to the AC mains power lead. Follow the instructions below if the mains plug has to be replaced.

The wires in the mains lead are coloured in accordance with the following code:

TERMINAL		WIRE COLOUR	
		European	USA/Canada
L	LIVE	BROWN	BLACK
N	NEUTRAL	BLUE	WHITE
E	EARTH GND	GREEN & YELLOW	GREEN

The wire which is coloured Green and Yellow must be connected to the terminal in the plug which is marked with the letter E or with the Earth symbol. **This appliance must be earthed.**

The wire which is coloured Blue must be connected to the terminal in the plug which is marked with the letter N.

The wire which is coloured Brown must be connected to the terminal in the plug which is marked with the letter L.

Ensure that these colour codes are followed carefully in the event of the plug being changed.

Precautions

- Damage :** To prevent damage to the equipment cosmetics, avoid placing heavy objects on the unit, scratching the surface with sharp objects, or subjecting the unit to rough handling and vibration.
- Environment :** Protect from excessive dirt, dust, heat and vibration when operating and storing. Avoid tobacco ash, smoke, drinks spillage, and exposure to rain and moisture. If the equipment becomes wet, switch off and remove power immediately. Allow to dry out thoroughly before using again.
- Cleaning :** Avoid the use of chemicals, abrasives or solvents. The equipment is best cleaned with a soft brush and dry lint-free cloth. If the ventilation grilles become blocked with dust use a vacuum cleaner to suck the dirt out. Do not remove the cover to clean the unit.
- Transporting :** The equipment should be transported in the original packing or purpose built flightcase to protect it from damage during transit.
- Cables:** Plan the location of the equipment so that the connecting cables are not fully extended. Full extension of the cables can stress the equipment and cables and may result in undesired performance. Ensure that the cables are located such that they cannot be stood on or tripped over.
- Modules:** Do not remove the modules from the unit while power is applied.

Introduction

This is the user guide for the Allen & Heath **iDR0** 'MiniRack' mix engine. We recommend that you read this fully before starting. Included is information on installing, connecting and operating the unit along with panel drawings, application drawings and technical specification. Whilst we believe the information in this guide to be reliable we do not assume responsibility for inaccuracies. We also reserve the right to make changes in the interest of further product development.

We are able to offer further product support through our worldwide network of approved dealers and service agents. You can also access our Web site (www.allen-heath.com) for information on our company and its pedigree, our full product range and our design philosophy. To help us provide the most efficient service please keep a record of your unit serial number, and date and place of purchase to be quoted in any communication regarding this product. The serial number is located on the rear panel.

The **iDR0** is one of many components that can connect together to create an iLive mixing system. For further information on configuring and using iLive please refer to:

iLive System Reference guide	AP6526
iDR0 Getting Started Guide	AP7284
iLive Getting Started Guide	AP7260
Allen & Heath Resource CD	AP4742
Allen & Heath web site	www.allen-heath.com
Firmware Release Notes	Downloadable from web site
Help file within system firmware	

Check the packing contents

Retain the product packing should you need to ship the product in future. You should find the following components:

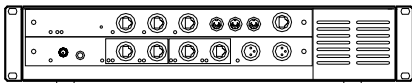

1x **iDR0** MiniRack. This is packed with its rubber feet fitted. The feet can be removed for rack mounting.

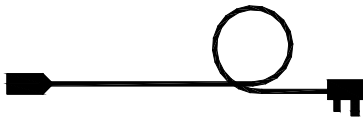

1x IEC MAINS LEAD with moulded plug. Check that the plug is suitable for connection to your local mains supply.

iDR0/n

Where n = mains voltage 120 (USA), 220 (EU), 240 (UK)

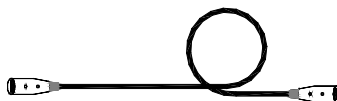

1x CAT5 CABLE 1.8m RJ45 Ethernet connections.

Part number **AH7001**. Connects the **iDR0** to the iLive Surface or another MixRack. Note that the second cable required is shipped with the iLive Surface.

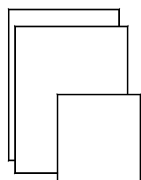

DOCUMENTATION including the User Guide **AP7129**, Getting Started Guide **AP7284**, Safety Sheet **AP3345**, Registration Card **AP3594**, and sticker **AP4943**.

Welcome to the iDR0 MiniRack

The **iDR0** is a compact, rack mountable unit housing the 'brains' of the iLive digital mixing system. It features a 64 input x 32 bus architecture with full channel and mix processing together with 8 internal effects processors. Unlike the bigger **iDR10** unit, the **iDR0** has no provision for fitting audio input and output cards. Instead, it gets its audio via the EtherSound digital audio network. This provides a compact solution for split FOH/monitor/recording applications or for stand alone systems where all the audio is available at the rear of the iLive Surface.

The two main applications for the **iDR0** are:

Split FOH/Monitor - Two iLive systems are linked using a single set of microphone preamps loaded into one rack. One system uses an **iDR10** which has 10 slots for loading the input and output modules including the mic preamps. The second system uses the smaller **iDR0** which has no audio slots and gets its channel sources from the first via an EtherSound 'digital splitter'. This can be more convenient, space saving and cost effective than loading two sets of preamps and using a bulky analogue splitter. One engineer has control over the preamp gains affecting both systems, while the second engineer has digital channel trims to make additional adjustments.

Compact stand alone mixer - The more compact **iDR0** MiniRack can be used in place of the larger **iDR10** MixRack to create a high quality small format mixer with all its audio inputs and outputs available on the rear of the Surface. Four card slots allow up to four input or output modules to be fitted providing a total of 32 sockets. For example, a typical format may be 24 inputs and 8 outputs. If you take into account the 8 internal stereo effects processors this provides the equivalent of an analogue console with 24 mono inputs plus 8 stereo inputs (returns) and 16 outputs (including the effects sends). In addition, further inputs and outputs may be connected via other EtherSound input and output devices.

The 2U case houses three plug-in modules – the iDR-64 'Rack-Extra' DSP mix engine, CPU control module with network, MIDI and PL-Anet interfaces, and RAB remote audio interface module with two EtherSound network cards fitted as standard, digital clock, and a headphones output at the rack. The ESA network transports audio to and from the Surface rear panel card options, while ESB provides a 64 channel digital snake to connect to another MixRack or EtherSound recording device. The user can map selected signals to and from the 64 channel EtherSound audio network. The DSP processes 64 input channels, 32 mix outputs and up to 8 internal effects, with full processing available at all times on all inputs and outputs.

Two CAT5 connecting cables are required between the **iDR0** and iLive Surface, one for Ethernet control, the other for EtherSound audio. One CAT5 cable is all that is needed to connect between two racks to link the audio between iLive systems.

The **iDR0** has an internal, universal voltage mains supply, and allows connection to the Allen & Heath **iPS10** rack mount psu if redundant supply backup is required.



GETTING STARTED...

A single sheet Getting Started guide (publication AP7284) is available for the **iDR0**. For your convenience it is reprinted here. Whilst it does give you a very quick way to start configuring and using iLive we do recommend that you read through the rest of this guide to learn more about the system first. →

The iDRO is similar to the iDR10 but without the slots for audio I/O cards. It is the iLive 'brain' with DSP mix engine, control and audio network interfaces. iDRO provides a compact solution for systems using EtherSound as a digital mic splitter, or as a stand alone mixer using audio at the rear of the surface.

1 CHOOSE YOUR APPLICATION

- [A] Stand alone mixer with audio at rear of surface
- [B] Split FOH/Monitor dual console system

2 CHOOSE SURFACE SIZE

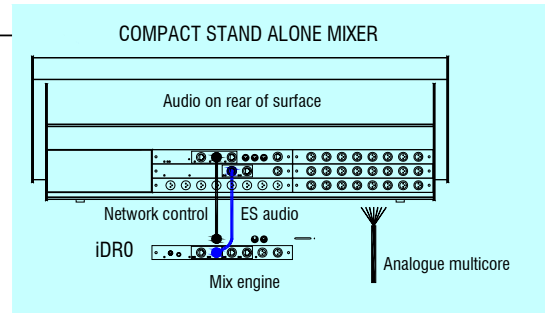
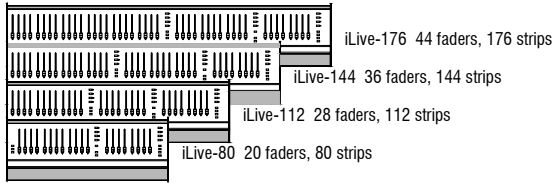

3 CHOOSE AUDIO MODULES FOR LOCAL AUDIO AT THE SURFACE

Load up to 4x 8 channel audio modules, eg - 24 inputs + 8 outputs

	BLANK	M-BLANK-A
	MIC/LINE	M-MICIN-A
	DUAL MIC	M-DUALIN-A
	DIGITAL IN	M-DIGIN-A
	LINE OUT	M-LINEOUT-A
	DIGITAL OUT	M-DIGOUT-A
	MULTI OUT	M-MULTI-OUT-A 16 outputs, takes up 2 slots

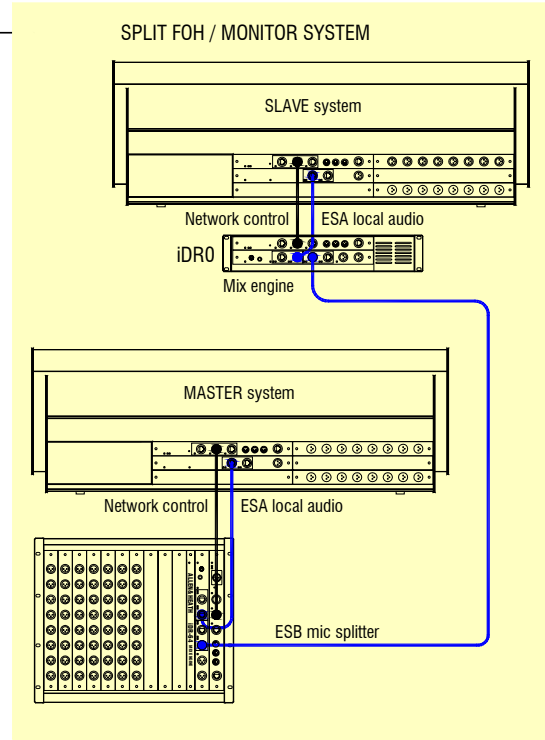

4 CONNECT UP THE SYSTEM

- Connect mains power leads
- Connect backup iPS10 power supplies if required
- Audio network - Plug iDRO ESA OUT to Surface ESA IN (1x CAT5 cable)
- Control network - Plug iDRO NETWORK to Surface NETWORK (1x CAT5 cable)
- If split FOH/Monitor system - Plug iDRO ESB IN from master iDR10 ESB out

5 POWER UP THE SYSTEM

- Switch on the MixRack and Surface
- The system should connect and boot up within 2 minutes

6 LOAD A TEMPLATE SHOW AS A STARTING POINT

- Press UTILITY / Configuration / Show Manager
- Select TEMPLATES from the left window
- Press + to expand the list
- Select and Recall a show as a starting point for using your system
- [A] iDRO_LR_24in8out Stand alone mixer with audio I/O at rear of surface
- [B] SLAVE_MON_8m8st Monitor console slave system
- [B] SLAVE_FOH_LR FOH console slave system

7 RECALL SCENE FOR SURFACE SIZE

- Gives you a logical layout for your Surface size
- Press SCENES - Select and recall scene STRIPnnn where nnn = surface size

8 CHECK AUDIO CLOCK AND ETHERSOUND SETTINGS

- Press MIXRACK / Mixer Pref / Audio Sync Networks
- Check Audio Clock setting (Chooses the source to synchronise the digital audio)
 - [A] INTERNAL Stand alone mixer with audio I/O at rear of surface
 - [B] ESB Slave FOH or Monitor system with ESB digital mic splitter
- Check EtherSound configuration (Configures the digital audio network mapping)
 - [A] MASTER Stand alone mixer with audio I/O at rear of surface
 - [B] MASTER/SLAVE Slave FOH or Monitor system with ESB digital mic splitter
- Check Channel Source settings (Chooses which inputs feed the channels)
 - [A] Local Inputs Stand alone mixer with audio I/O at rear of surface
 - [B] ESB Inputs Slave FOH or Monitor system with ESB digital mic splitter

If the Surface audio does not appear where you expect it:
 eg. If it has been changed using an external application such as ES Monitor
 You can restore the EtherSound configuration to standard mapping using this:

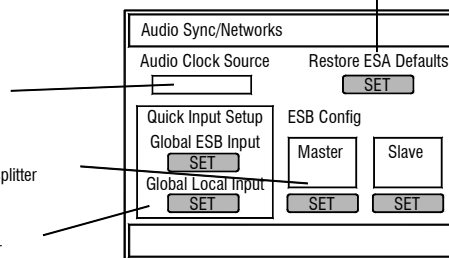

9 CHECK INPUT SOCKET MAPPING

- From IP channel PREAMP screen check for required socket patching
- [A] Surface Slot A-D Stand alone mixer
- [B] ESB ch 1-64 Slave FOH or Monitor system with ESB digital mic splitter

10 CHECK OUTPUT SOCKET MAPPING

- Press OUTPUTS / Surface to check which signals feed the Surface output sockets
- Surface Slot A-D Stand alone mixer outputs or local slave outputs

11 ARCHIVE YOUR SETTINGS

- Name and archive your setup as a Show for each iLive (eg. FOH and Monitor)
- You could also store your settings as a Scene memory (Select All)

12 MORE... Refer to the iLive REFERENCE GUIDE for more on configuring and using iLive
 Refer to the FIRMWARE RELEASE NOTES for more on new features
 Refer to WWW.ALLEN-HEATH.COM for the latest information on iLive

Installation

Free standing

The **iDR0** can be operated as a freestanding unit for shelf or floor operation. Check that its plastic feet are fitted. Ensure adequate air flow around the unit. It must not be covered in any way. Always stand the unit on a firm flat surface away from any soft furnishings or carpet.

Rack mounting

The **iDR0** is designed as a 19 inch rack mount unit and will occupy 2U (3.5 inches) of rack space. The plastic feet may need to be removed before rack mounting. Retain the feet for future use. Ensure natural convection of airflow around the unit by allowing good ventilation below, in front of and behind the unit. Rack equipment known to produce a significant amount of heat should not be mounted directly below the unit. Forced convection by means of a rack mounted fan-tray may be desirable in situations where space is restricted and the ambient air temperature is high.

Flight casing

We recommend that you use a professional grade flight case with shock mounted internal rack frame. Ensure adequate ventilation in front of and behind the unit when it is powered.

Cables

Make sure the cables are not stretched in any way and are routed to avoid becoming kinked or damaged. Allow enough service loop for access and removal of the unit. Ensure all connectors are fully plugged in and locked.

CAT5 cables

iLive systems are shipped with 1.8 metre CAT5 cables as standard. Depending on type, cables up to 100 metres (330 feet) may be used for applications where the Surface is positioned remote from the MiniRack. Cable approved by Digigram for EtherSound use should be sourced. Check the Digigram web site for further information (www.ethersound.com/technology/compatibility.php). Allen & Heath can supply an 80 meter drum of suitable cable if needed, part number **AH7000**. Two of these are required to connect control and audio between the MiniRack and the Surface. One is required to connect audio between the MiniRack and another remote rack.

Dimensions

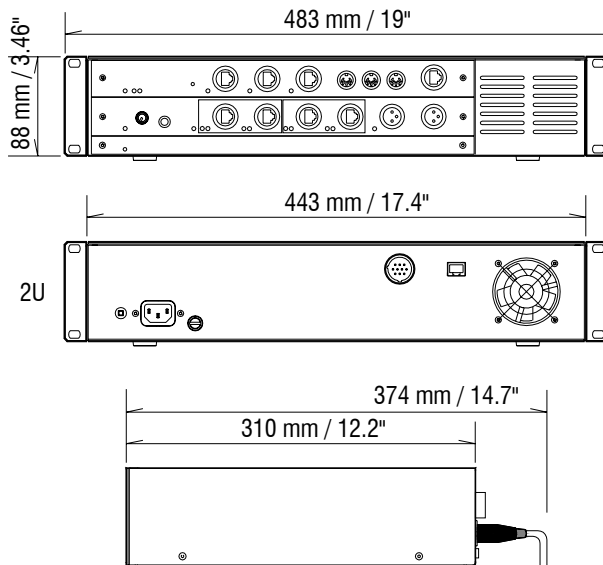

▲ Do not obstruct the ventilation slots. Ensure adequate air flow around the iPS10.

▲ Ensure proper grounding. Do not remove the IEC mains cord earth (ground) connection.

▲ Do not remove the cover or modules of the iDR0. There are no user serviceable parts inside.

Front panel controls, connections and operation

CPU (Control) module

Allows control of the system using an iLive Surface, PC or other devices.

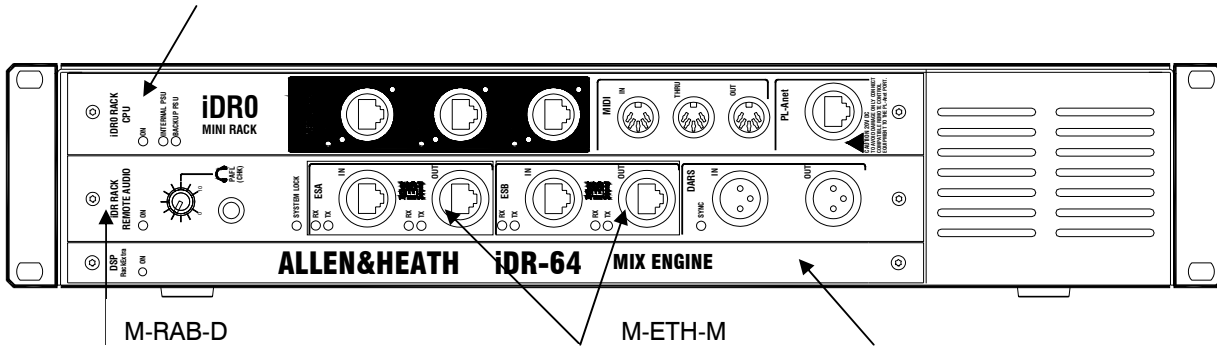

RAB (Remote Audio) module

Connects audio to and from the rack using a single cable digital format for each of two independent audio networks.

Audio network card options

Up to two cards may be fitted. The ES (EtherSound) card handles 64 channels of bi-directional audio.

iDR-64 RackExtra DSP module

The audio 'mix engine' which digitally processes up to 64 input channels, 32 mix outputs and 8 internal effects.

CPU module

Power indicators - Blue LEDs light to indicate power present.

NETWORK - A 3 port Ethernet switcher is built in. This lets you connect several network devices to the **iDR0**, for example an iLive Surface and a laptop running the iLive System Manager software. While searching for the connection after device power up, the LINK/ACT indicator flashes at a slow rate. This may take a few seconds. Once the connection is successfully made the indicator flashes at a steady fast rate.

Note: Do not connect more than one network cable between two devices. Attempting to connect a second cable as a 'redundant backup' will result in loss of control.

Note: When using firmware versions up to V1.2, disconnection of the network cable or loss of network connection requires a Surface reboot.

Reset Settings - A recessed switch lets you reset the network address and settings to factory default. This is useful if you are using a MiniRack and a Surface with unknown network addresses or which had different addresses previously set. Resetting each networked device (MiniRack, Surface and TouchScreen) will ensure the devices connect correctly. To reset the settings, press and hold the switch in using a pointed object while powering up the rack. Keep the switch pressed for at least 10 seconds while the rack boots.

Default MiniRack settings are:

IP address 192.168.1.1
Subnet mask 255.255.255.0
Gateway 192.168.1.254

MIDI IN, THRU and OUT - Standard MIDI interface for external system control using MIDI messages. For more information refer to the iLive Reference Guide and firmware version release notes.

PL-Anet - Proprietary RS485 based control port for connecting Allen & Heath PL Series remote controllers such as wall plates, GPIO and fader/encoder panels. For more information refer to the iLive Reference Guide, PL Series guides and firmware release notes.

RAB module

Power indicator - A blue LED lights to indicate power present.

HEADPHONES - A built-in headphones amplifier with volume control and ¼" output socket lets you listen to the signal currently selected using the PAFL function. This is the same signal presented to the Surface headphones system.

SYSTEM LOCK - The yellow LED lights to indicate digital audio sync lock. If it is not lit check that the correct Audio Clock Source is selected.

Audio Clock Source (Surface TouchScreen MIXRACK / Mixer Pref / Audio Sync) - If the **iDR0** is the slave getting its channel preamp sources via EtherSound network ESB in a linked FOH/Monitor system then the Clock Source should be set to 'ESB'. If it is being used as a stand alone system getting its audio from the Surface via ESA only then it should be set to 'Internal'. If it is being synchronized to an external DARS source then set it to 'DARS'.

ESA and ESB audio network options - The **iDR0** is shipped as standard with both card slots fitted with the EtherSound option. Use ESA to transport audio to and from the iLive Surface and/or other EtherSound equipped devices such as break out / break in boxes and speaker controllers. Use ESB to transport audio between iDR racks and other EtherSound equipped devices such as the Digigram LX6464 PCI multitrack recording card.

ESB Config (Surface TouchScreen MIXRACK / Mixer Pref / Audio Sync) - This screen lets you configure the **iDR0** to be the EtherSound master or slave. For example, if it is a slave in an FOH/Monitor system then set it to MASTER/SLAVE. If it is being used with a Surface as a stand alone mixer then set it to MASTER. This config setting is not stored in the iLive Show memories and should be set manually when you configure the system.

ES IN and OUT - Plug a single CAT5 cable to connect audio between the MiniRack and another device. Plug OUT to IN. Plug into the OUT socket on whichever device is the audio clock master. Plug into the IN socket on the slave device.

For example, if the **iDR0** is a monitor slave getting its mic signals digitally split from the FOH **iDR10** master via ESB, then connect the **iDR10** ESB OUT to the **iDR0** ESB IN sockets using a single cable.

To connect the **iDR0** to the Surface audio modules, headphones and talkback, connect its ESA OUT to the Surface ESA IN socket.

Correct connection of EtherSound is indicated by the steady flashing of both the yellow RX and TX LEDs. If neither or just one is flashing then check for correct connection or a cable fault. The EtherSound connection is made as soon as the cable is plugged in.

Note: Only one cable is required to connect the audio to and from the remote device. Connect OUT on the master device to IN on the slave device. This refers to the clock master, not audio direction. Do not connect OUT to IN and IN to OUT using two cables.

DARS IN and OUT - This lets you synchronize the **iDR0** audio clock to an external device, or synchronize the external device to the **iDR0** audio clock using the AES Digital Audio Reference System standard.

To learn more about using EtherSound refer to the Digigram web site:

www.digigram.com/

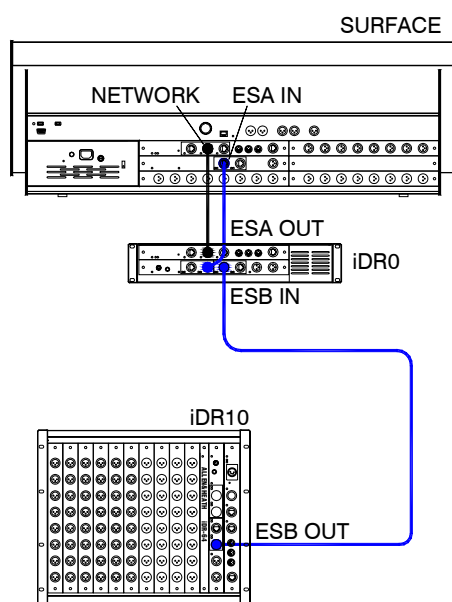

Rear panel connections and operation

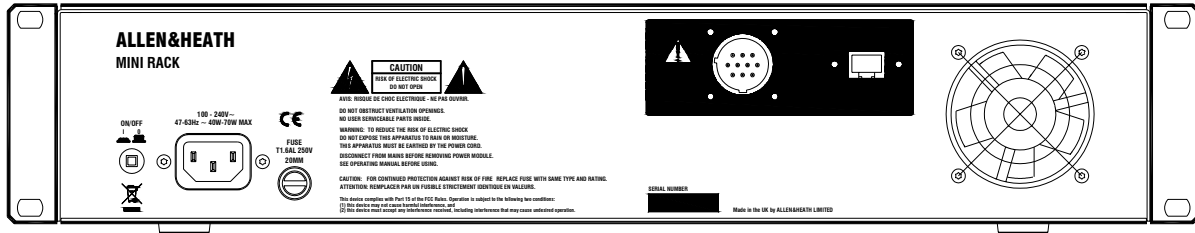

MAINS INPUT - An IEC mains power cord with moulded plug suitable for your territory is shipped with the **iDR0**. Refer to your Allen & Heath agent if the incorrect type has been provided. The **iDR0** has an internal universal voltage power unit that accepts world wide mains sources from 100 to 240V.AC 47 to 63Hz. Make sure the IEC plug is pressed fully into the panel socket before switching on.

Note: To ensure operator safety, connect only to an approved and properly grounded mains source. Do not remove the ground connection in the mains cord.

Note: Read and understand the warnings in the safety sheet supplied with this unit and printed on the rear panel.

MAINS FUSE - In the event of a fuse failure replace only with the correct type and rating as indicated on the rear panel. If the replacement fuse fails again, switch off and refer to your Allen & Heath service agent.

ON/OFF switch - Press to toggle mains power on or off.

Note: Always turn on the MiniRack first, then the iLive Surface. Powering the surface up first may result in failure to connect or loss of EtherSound audio at the surface. Power off the surface before turning off the MiniRack.

BACKUP SUPPLY INPUT - If required, connect the optional Allen & Heath **iPS10** external rack mount power unit for redundant supply backup. The **iDR0** can operate with either or both the internal and backup supply switched on. The audio continues uninterrupted when switching between units. Refer to the **iPS10** user guide for more information.

Note: Connect only the specified power unit and cables. The correct DC and Temperature Monitor cables are provided with the **iPS10**. Do not extend or modify these in any way.

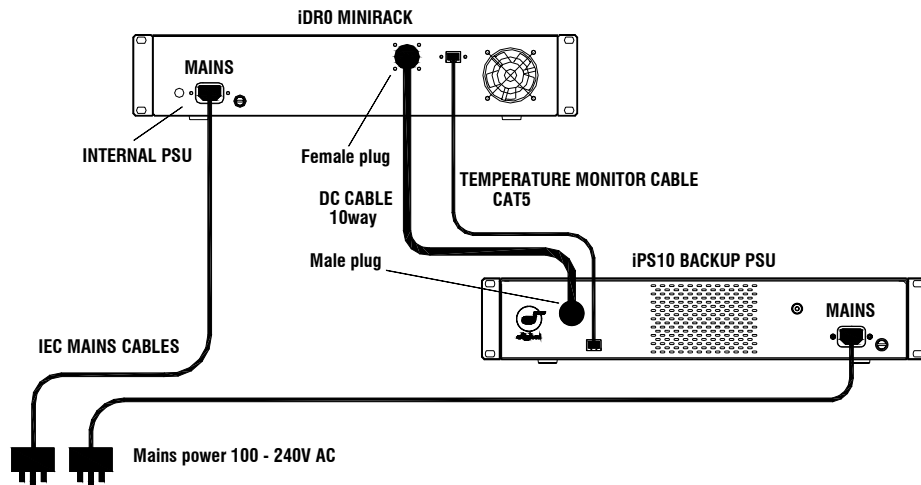

Using the iDR0

There are several ways the **iDR0** can be used within an iLive system. It is just one of many component options that may be configured to satisfy a host of demanding audio mixing applications. We recommend that you visit the Allen & Heath web site for information on the full range of iLive components available. You can also download additional application drawings which illustrate the versatility of iLive in satisfying many basic and advanced applications.

Refer also to the **iDR0** Getting Started Guide AP7284 printed earlier in this guide and also to the iLive System Reference Guide AP6526. Further information on the latest features is available in the Release Notes which come with each firmware release. Check our web site to download the latest version of iLive firmware.

The following pages illustrate some of the **iDR0** applications. They are based on preconfigured 'template' Show memories which can be recalled from the Surface UTILITY / Configuration / Show Manager screen. These give you a good starting point by configuring a recognisable classic architecture and surface layout. You can edit these and name and store your customised configurations as User Shows.

APPLICATION EXAMPLE - iDR0 WITH iLIVE AS A STAND ALONE MIXER

24 inputs, 8 outputs compact system.

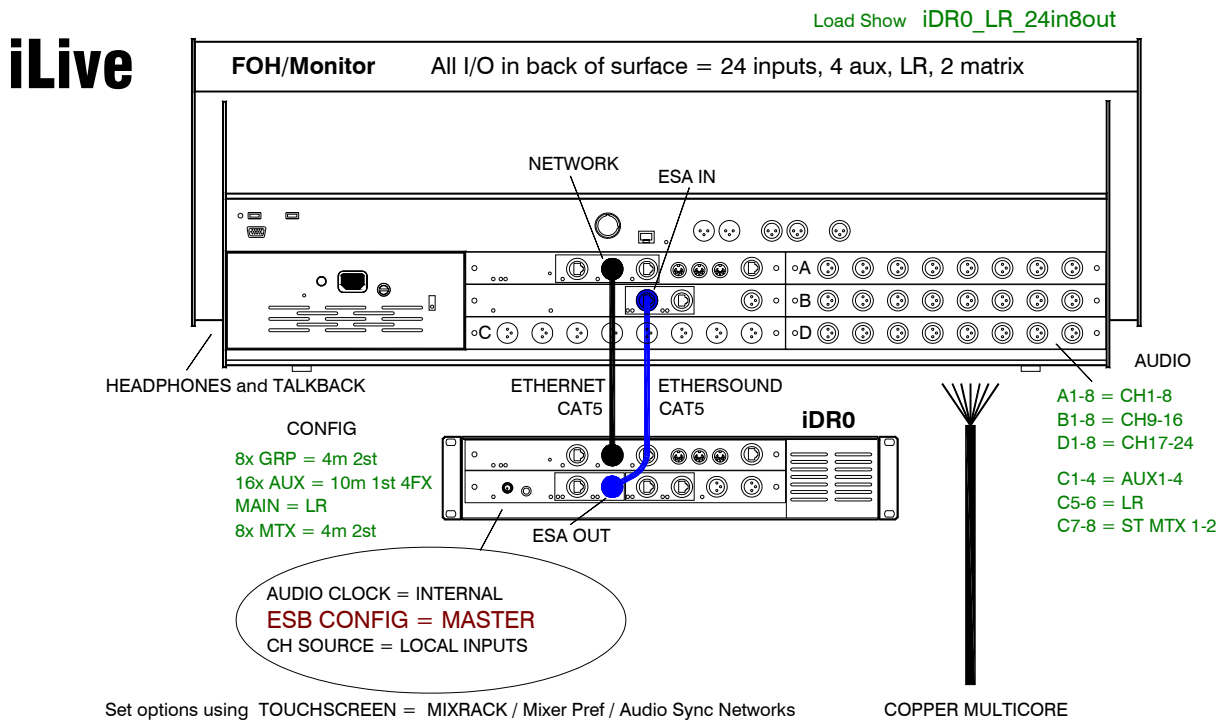

APPLICATION EXAMPLE - FOH / MONITOR (iDR0 at Monitors)

64 inputs FOH, 56 way split. FOH engineer has gain control.

iLive

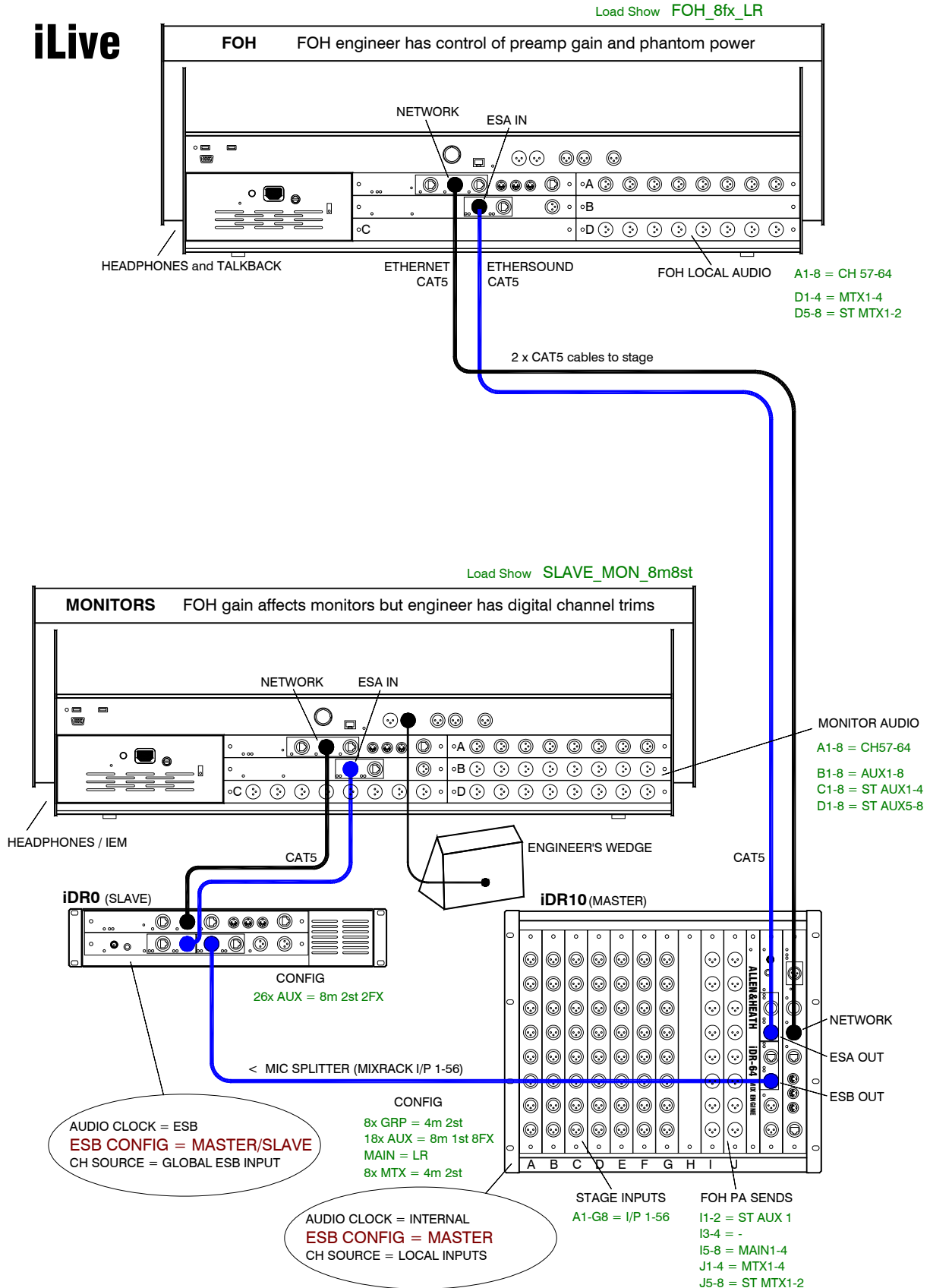

Set options using TOUCHSCREEN = MIXRACK / Mixer Pref / Audio Sync Networks

APPLICATION EXAMPLE - FOH / MONITOR (iDR0 at FOH)

64 inputs FOH, 56 way split. Monitor engineer has gain control.

iLive

Load Show **SLAVE_FOH_LR**

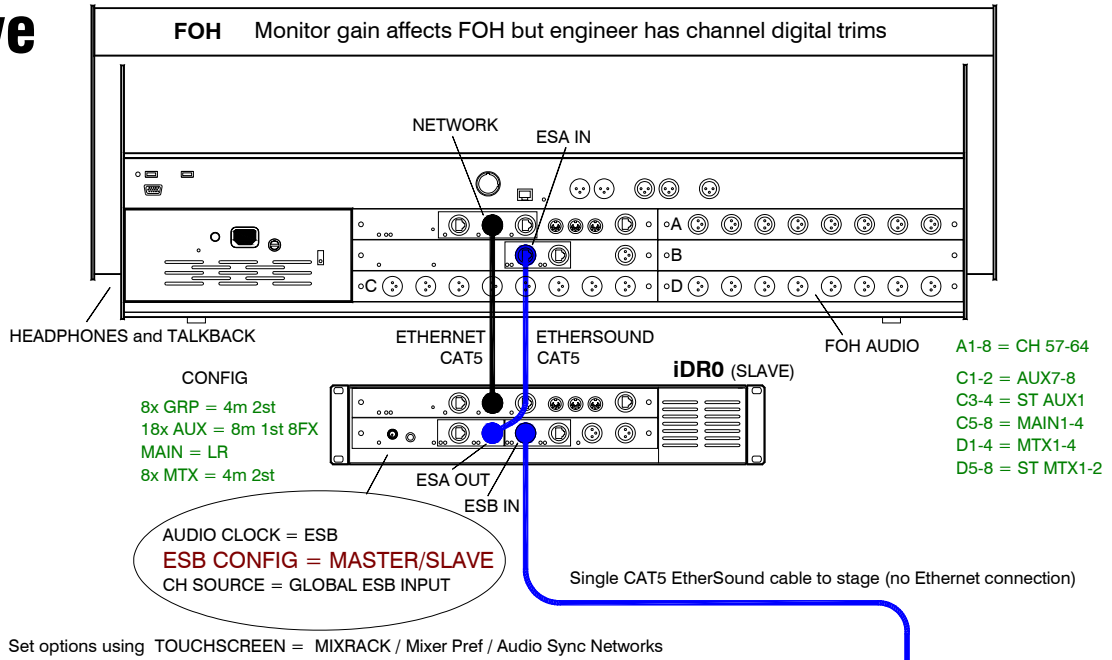

Load Show **MON_2fx_8m8st**

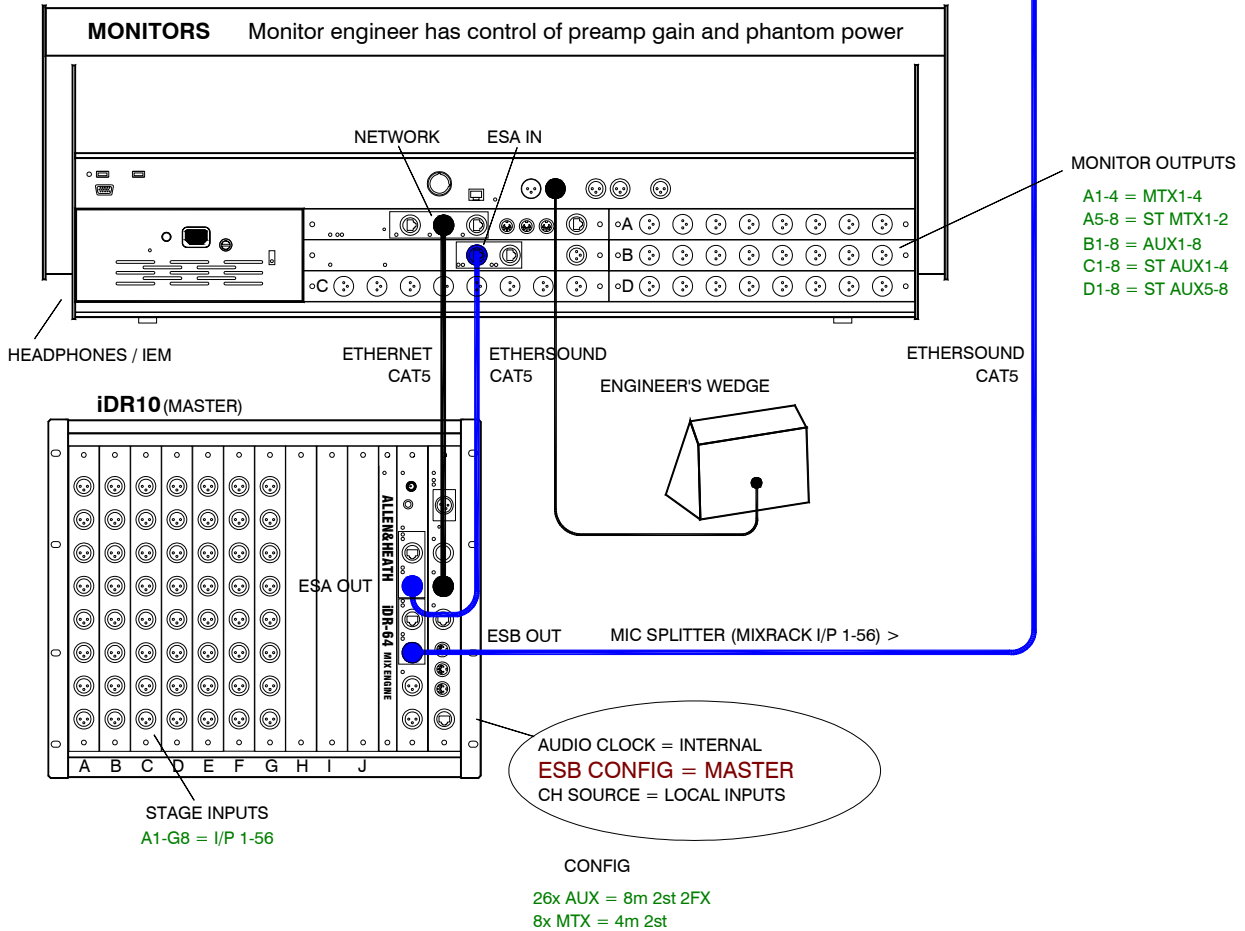

APPLICATION EXAMPLE - FOH / MONITOR (iDR0 at FOH, No ESA on Monitor)

56 inputs FOH, 48 way split. No ESA on monitor system. Monitor engineer has gain control.

iLive

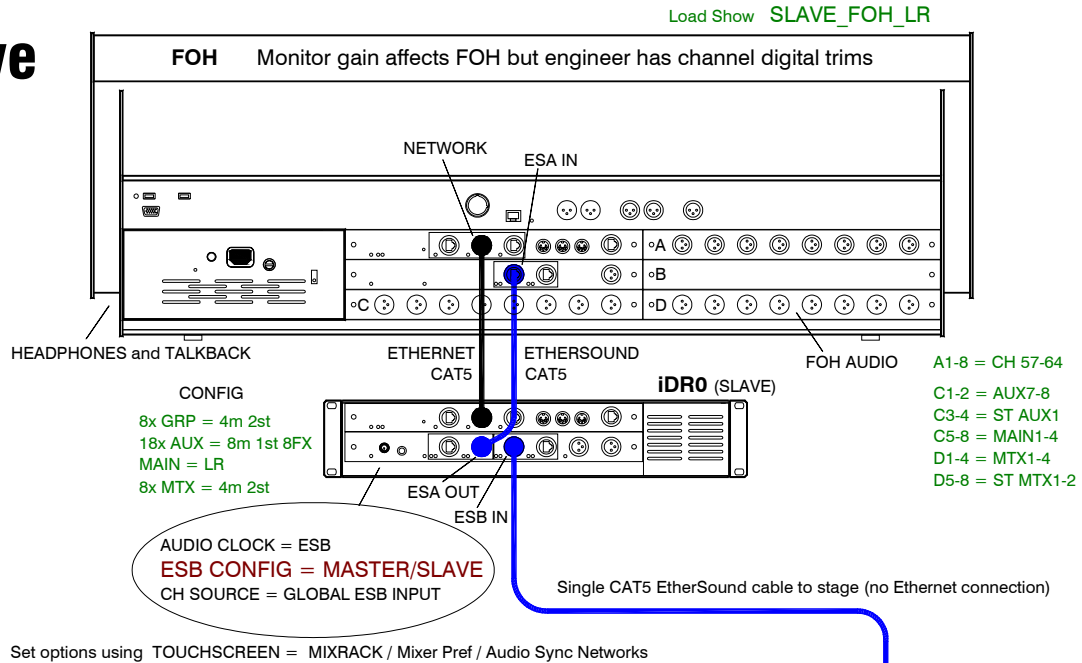

Set options using TOUCHSCREEN = MIXRACK / Mixer Pref / Audio Sync Networks

