

DL151

24-Input Stagebox with
MIDAS Mic Preamps and
Dual-Redundant AES50 Networking

- 24 award-winning MIDAS analogue mic preamps with switchable +48 V phantom power
- Selectable 96 kHz or 48 kHz sample rate operation
- Dual AES50 Neutrik etherCON* network ports with LED status indicators
- All settings programmable from front panel controls or console
- Remote operation up to 100 m via CAT5 cable
- PSU status indicator LEDs and configuration LCD display on front panel
- Rugged 2U rackmount chassis for durability in portable applications
- Auto-ranging universal switch-mode power supply
- 3-Year Warranty Program**
- Designed and engineered in England



The DL151 delivers legendary MIDAS sound quality in a cost effective, discrete 2U chassis that utilises time-tested and proven MIDAS technologies. Equipped with 24 channels of MIDAS premium mic-pre amplifiers with 2.5 dB gain steps and dual redundant AES50 networking ports, the DL151 is the ideal partner to the PRO 1 / PRO 2 digital consoles – significantly increasing the network capacity and number of mic. inputs.

User interface controls and feedback is via an intuitively laid out front panel. The controls and LED indicators provide ease of use and instant feedback at a glance. All primary connections use high quality balanced XLR connectors.

Housed in a road-ready, rugged 19" 2U rack-mountable chassis, the DL151 is ideally suited for storage in standard flight cases (not included).

Integration Within The MIDAS Product Range

Styled to match our existing console aesthetic, MIDAS high performance I/O has never been easier to use - or more cost effective.



*All third-party trademarks, including, but not limited to Neutrik and etherCON are trademarks or registered trademarks of their respective owners. Their use neither constitutes a claim of the trademark nor affiliation of the trademark owners with MUSIC Group. Product names are mentioned solely as a reference for DL151 compatibility, effects and/or components.

**Warranty details can be found at music-group.com

DL151

24-Input Stagebox with
MIDAS Mic Preamps and
Dual-Redundant AES50 Networking

Front Panel Description

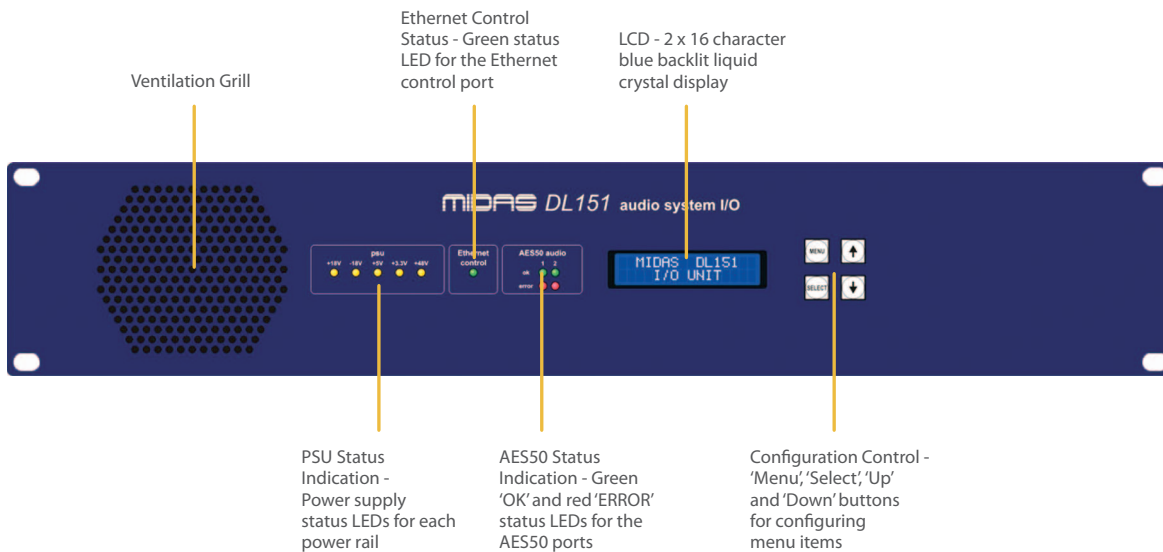

Rear Panel Description

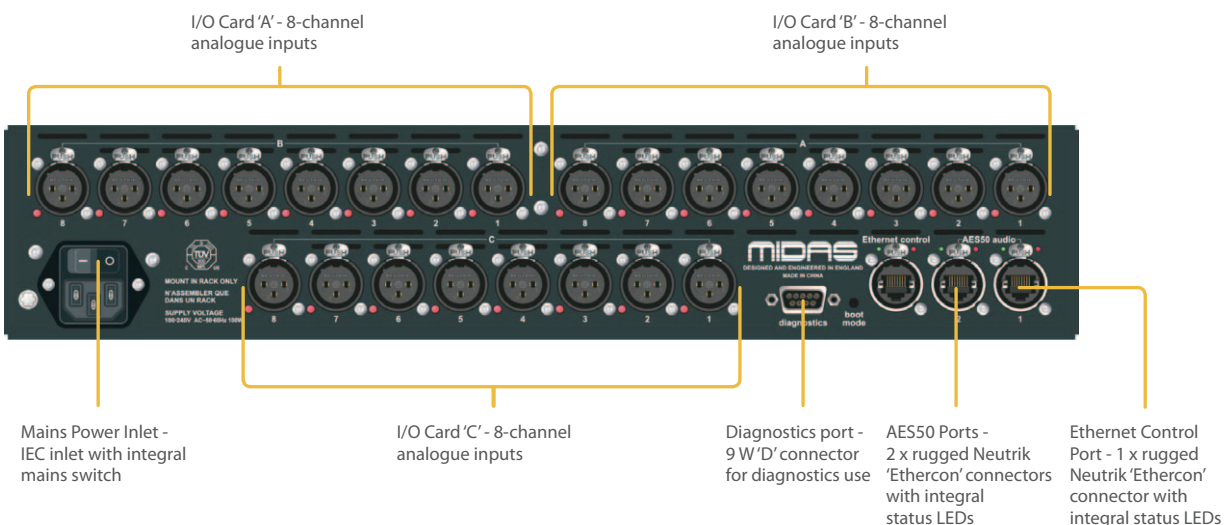

DL151

24-Input Stagebox with
MIDAS Mic Preamps and
Dual-Redundant AES50 Networking

Specifications

External Connections

Primary Analogue Inputs	Mic / Line inputs - balanced XLR connectors - 10 k Ω load
AES50 Connections	Neutrik etherCON with status indication
Diagnostic Connection	9 W female 'D'-type connector
Power Connections	IEC mains inlet - 100 - 240 V AC - 50 - 60 Hz \pm 10%

Audio Electronic Specifications

Maximum Input Level

Mic/Line (at unity gain)	+21 dBu
Mic/Line (at -2.5 dB gain)	+24 dBu

CMR at 1 KHz (typical)

Mic (at unity gain)	> -70 dB
Mic (at 40 dB gain)	> 90 dB

Noise

Mic EIN at 40 dB gain	-126 dBu
Output noise at unity gain	-87 dBu

Frequency Response

(20 Hz - 20 kHz), relative to 1 kHz	\pm 0.5 dB
--	--------------

Distortion at 1 kHz

Input to output (0 dB)	< 0.01%
------------------------	---------

Crosstalk at 1 kHz

Channel to channel	< -90 dB
--------------------	----------

Dynamic Range at 1 kHz

22 Hz - 22 kHz (at unity gain)	> 108 dB unweighted (20 Hz - 20 kHz)
--------------------------------	--------------------------------------

Power Requirements

Voltage	100 V AC to 240 V AC \pm 10%
Frequency	50 Hz to 60 Hz
Consumption	<150 W

Physical

Height	Approx 88.1 mm (2U)
Width	Approx 482.6 mm (19.0")
Depth	Approx 380 mm (15.0")
Net Weight	Approx 5 kg (11 lbs)
Shipping Weight	Approx 6 kg (13.2 lbs)
Operating temperature range	+5°C to 45°C
Storage temperature range	-20°C to +60°C

Neutrik and etherCON are registered trademarks of Neutrik AG

DL151

24-Input Stagebox with
MIDAS Mic Preamps and
Dual-Redundant AES50 Networking

Architect's & Engineer's Specification

The MIDAS DL150 series of I/O units are a one piece solution housed in a rugged 19" 2U rack mount chassis with cosmetic trim suitable for use and storage in a road flight case.

All user interface controls and feedback are located on the front panel. User interface controls are laid out for ease of operation with consideration for the amount of user feedback required. All switches are high quality momentary type with integral blue LED illumination and printed switch caps.

All primary connectors are on the rear of the unit. All inputs and outputs are on balanced XLR connectors. All analogue audio inputs and outputs are tolerant of 48 V connection and short circuit protected. The DL150 series only use Neutrik XLR connections.

The DL150 series I/O units are mixed technology products combining analogue and digital circuitry. These are combined on the input and output cards using multi-layer horizontal PCBs, extreme care has been taken when planning and executing the PCB layout to maintain good grounding and analogue / digital separation.

The DL150 series units use proven technology from the D251 I/O unit from the current MIDAS range. The analogue input and output cards are identical, the AES3 digital card is similar to the one used in the PRO2 surface and the CPU card is a modified version of the one used in the DL251.

The DL150 units use an internal switch-mode power supply.

The user interface software is based on the same menu system currently used on the DL451 and has provision for all of the functions these units can perform.

For service, support or more information contact the MIDAS representatives nearest you:

Europe
MUSIC Group Services UK
Tel: +44 156 273 2290
Email: CARE@music-group.com

USA/Canada
MUSIC Group Services NV Inc.
Tel: +1 702 800 8290
Email: CARE@music-group.com

Japan
MUSIC Group Services JP K.K.
Tel: +81 3 6231 0454
Email: CARE@music-group.com

MUSIC Group accepts no liability for any loss which may be suffered by any person who relies either wholly or in part upon any description, photograph, or statement contained herein. Technical specifications and appearances are subject to change without notice. All trademarks are the property of their respective owners: BEHRINGER, BUGERA, KLARK-TEKNIK, MIDAS, and TURBOSOUND are trademarks or registered trademarks of MUSIC Group IP Ltd. © MUSIC Group IP Ltd. 2013 All rights reserved.

