

Eight-channel mic line amplifier for exceptionally clear sound reproduction



Rear Panel

MIC LINE AMPLIFIER MLA8

An eight-channel head amplifier inheriting the head-amp technology of the acclaimed DM2000 for high-quality sound reproduction

Having won the plaudits of professional engineers from live mixing venues, music production studios, and countless other areas, Yamaha's acclaimed DM2000 Digital Production Console provides the head-amp technology used in the MLA8's basic circuit design. Meticulously reproducing the original sound with breathtaking clarity, this head amp achieves stunning audio quality.

Highly practical functions in a compact 1U package

Notwithstanding its space-saving 1U design, the MLA8 front panel equips you with a 26dB pad, a 44dB fully adjustable gain trim, an 80Hz HPF, and a phantom-power switch on each channel. This HPF processes audio signals while still in analog format; accordingly, in systems combining MLA8s with Yamaha digital mixers, DME64Ns, and DME24Ns, sound control is simple and the range can be further broadened. Put simply, MLA8s with digital mixers and DMEs produce the perfect combination.

Consistent functional colors for highly-convenient operation

Functional colors for Yamaha mixers are selected based on a set of common rules. Similarly, the MLA8 uses green for signal indicators and HPFs, red for peak indicators, and gray for pads. In systems where this head amplifier is combined with other Yamaha products, the resulting ability to identify component functions at a glance helps to realize an environment where operations can be carried out quickly, intuitively, and without error.

Euroblock and 25-pin D-sub connectors for highly adaptable system support

XLR connectors are used for the input of audio, and amplified sound is output via a Dsub-25pin and a Euroblock — an ideal connector for installation. Dsub-25pin terminals are compatible with the MY8-AD96 8-channel Mini-YGDAI* A/D card, and this ensures a high degree of affinity with Yamaha digital mixers.

Addition of mic inputs for digital mixers

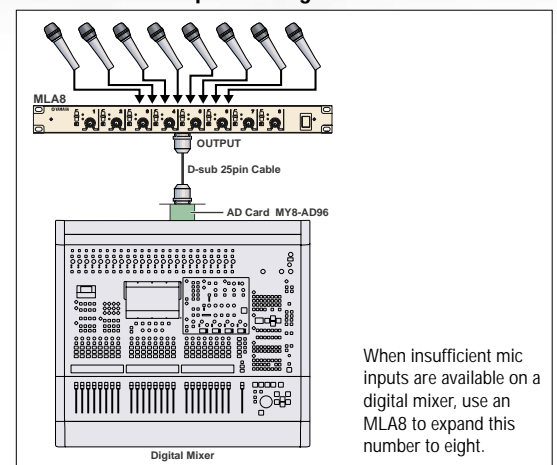

Mic input for DME64N, DME24N Digital Mixing Engines

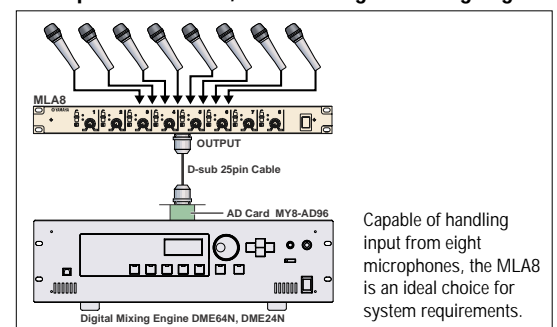

*: Yamaha General Digital Audio Interface

MLA8 SPECIFICATIONS

Electrical Characteristics

	Conditions	MIN	TYP	MAX	UNIT
Total Harmonic Distortion (THD+N)	20 Hz - 20 k Hz @ +14 dBu, 10 k ohms, GAIN Maximum			0.1	%
	20 Hz - 20 k Hz @ +14 dBu, 10 k ohms, GAIN Minimum			0.01	%
Frequency Response	20 Hz - 20 k Hz @ +4 dBu, 10 k ohms, GAIN Maximum	-1	0	0.5	dB
	20 Hz - 20 k Hz @ +4 dBu, 10 k ohms, GAIN Minimum	-0.5	0	0.5	dB
Hum & Noise (20 Hz - 20 k Hz)	PAD OFF, GAIN Maximum (Sensitivity = -60 dBu)			-128 (68 dB S/N)	dBu
	PAD ON, GAIN Maximum (Sensitivity = -34 dBu)			-99 (65 dB S/N)	dBu
RS=150 ohms	PAD OFF, GAIN Minimum (Sensitivity = -16 dBu)			-108 (92 dB S/N)	dBu
	PAD ON, GAIN Minimum (Sensitivity = +10 dBu)			-82 (92 dB S/N)	dBu
Maximum Voltage Gain	CH IN to CH OUT		64		dB
Crosstalk Adjacent Inputs	@ 1 k Hz			-90	dB
	PAD ON, GAIN Minimum @ 10 k Hz			-70	dB
CH INPUT GAIN control	variable		44		dB
CH INPUT PAD switch			26		dB

0 dBu is referenced to 0.775 V rms.

Input Characteristics

PAD	Gain	Actual Load Impedance	For Use With Nominal	Input Level *1		Connector In Amplifier unit
				Nominal	Max. before Clip	
0	-60	3 k ohms	50 - 600 ohms Mics 600 ohms Lines	-60 dBu (0.775 mV)	-40 dBu (7.75 mV)	XLR-3-31type (balanced)
26				-34 dBu (15.5 mV)	-14 dBu (155 mV)	
0	-16			-16 dBu (123 mV)	+4 dBu (1.23 V)	
26				+10 dBu (2.45 V)	+30 dBu (24.5 V)	

*1: 0 dBu is referenced to 0.775 Vrms.

Output Characteristics

Actual Source Impedance	For Use With Nominal	Output Level *1		Connector In Amplifier unit
		Nominal	Max. before Clip	
150 ohms	10 k ohms Lines	+4 dBu (1.23 V)	+24 dBu (12.3 V)	Euroblock connectors (balanced) D-SUB 25P female connector (balanced)

*1: 0 dBu is referenced to 0.775 Vrms.

General Specifications

CH High Pass Filter	80 Hz, 12 dB/octave Turn over /roll-off frequency of shelving : 3 dB below maximum variable level.
Phantom Power	+48 V DC is applied to balanced inputs for powering condenser microphones via 6.8 k ohmsB
CH PEAK LED	One red LED per channel. Comes on when post - GAIN signal level reaches -17 dBu.
CH SIGNAL LED	One green LED per channel. Comes on when post GAIN signal level reaches -10 dBu.
Included Accessories	Power Supply Cord, Euroblock Connectors (3P x 8), Rubber Feet (x 4), Owner's Manual
Power Consumption	25 W
Dimensions (W x H x D)	480 mm x 44 mm x 375.5 mm
Weight	4.7 kg

D-sub 25pin Assignment Table

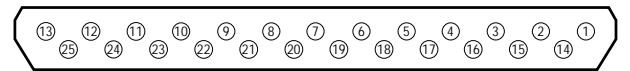

NC	G	C	H	G	C	H	G	C	H	G	C	H	G	C	H	G	C	H	G	C	H	
	CH1		CH2		CH3		CH4		CH5		CH6		CH7		CH8							

G:GND
C:COLD
H:HOT

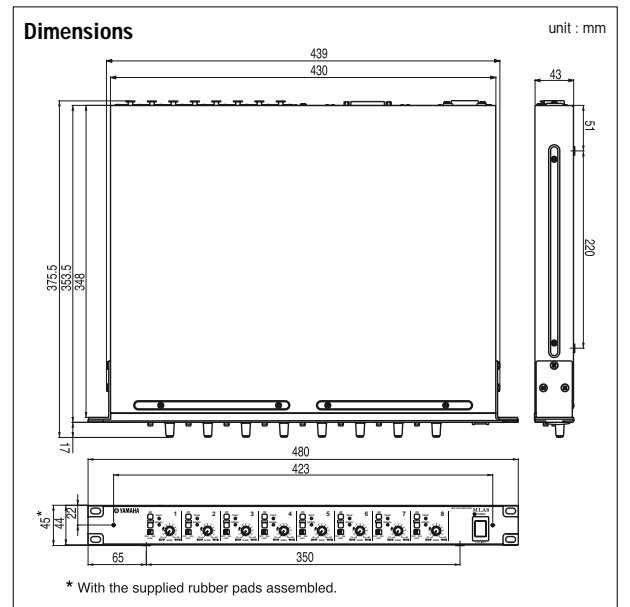

YAMAHA CORPORATION
P.O.BOX 1, Hamamatsu Japan

<http://www.yamahaproaudio.com>



This document is printed on chlorine-free (ECF) paper with soy ink.

YAMAHA
CREATING 'KANDO' TOGETHER
'KANDO' ...Inspiring the Heart and Spirit.

LPA482 Printed in Japan