

# DS5/DS10/DS20 Fluid Head Operator's Manual



- #180 DS5 Fluid Head
- #182 DS10 Fluid Head
- #184 DS20 Fluid Head



# Features and Controls

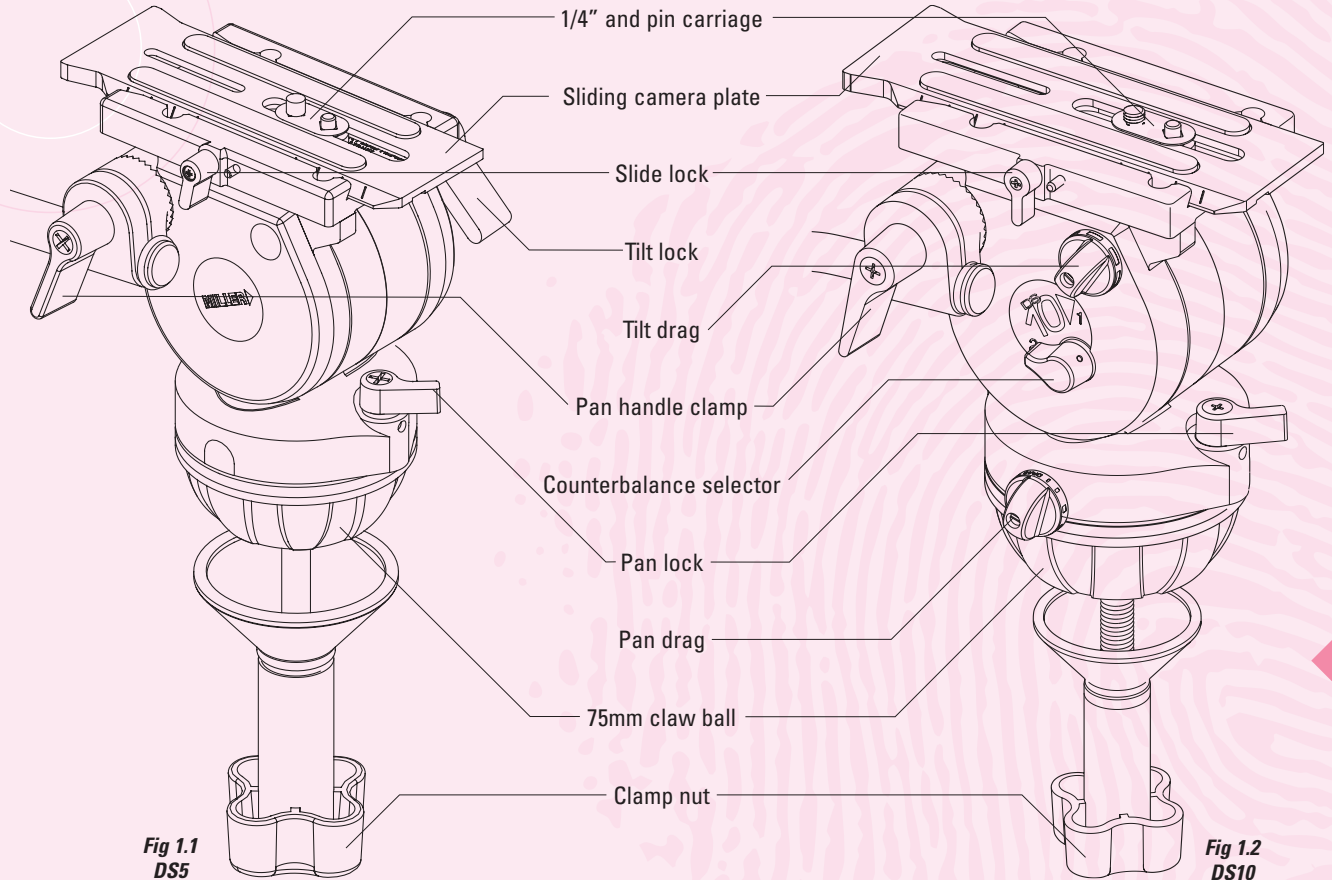

# Introduction

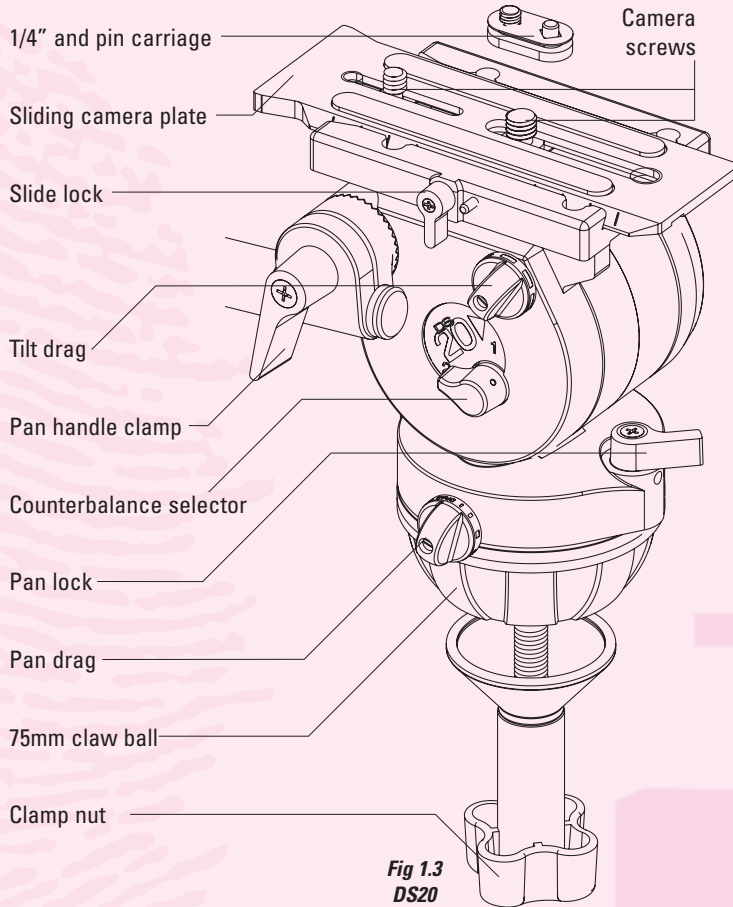

Thank you for purchasing the Miller DS5/DS10/DS20 fluid head for use with our professional tripods and portable video camcorders. All fluid heads are 75mm ball levelling design and boast similar physical appearance and size. The DS5 utilises a single position counterbalance system to handle camera payloads up to 2.5kg (5.5lb). The DS10 utilises 2 selectable counterbalance positions to handle payloads from 2.5-5kg (5.5-11lb) while the DS20 offers 2 selectable counterbalance positions for larger camcorders ranging from 5-10kg (11-22lb).

The DS5/DS10/DS20 fluid head is designed for maximum stability, accuracy and repeatability and includes 4 precision ball bearings and a fluid drag plate system in the pan and tilt assembly to deliver true fluid drag performance over a wide temperature range and payload. The DS10/DS20 fluid head also includes a friction drag adjustment.

The DS5/DS10/DS20 fluid head will give best performance when used on Miller SOLO DV (#1630, #1501) or Toggle Lightweight DV (#440, #420) tripod. This will ensure maximum system stability to suit any professional set-up. The DS5/DS10/DS20 fluid head will fit most industry standard 75 mm tripods as well, please refer to manufacturers' manual for mounting details.

## Handle Mounting

The DS5/DS10/DS20 fluid head is supplied with a fixed length pan handle and clamp fitted to the right side of the head. A second pan handle can be attached to the DS5/DS10/DS20 for dual pan handle operation. Refer to spare parts section.

# Operating Instructions

Before using please read the following operating instructions. Do not omit any step. N.B. The safe operation of this piece of professional equipment is the responsibility of the operator.

## 1. Fluid Head Set-up

- 1.1 Loosen the PAN HANDLE CLAMP fully, then rotate the PAN HANDLE until it is approximately perpendicular to the THREADED STUD and tighten the PAN HANDLE CLAMP - avoid contact wear between the serrations on the Fluid Head and the PAN HANDLE CLAMP, if this occurs then unwind the PAN HANDLE CLAMP further.
- 1.2 Ensure that the TRIPOD BOWL is approximately horizontal. Place the Fluid Head into the TRIPOD BOWL, adjust the BUBBLE LEVEL such that the bubble is inside the black circle and tighten the CLAMP NUT.

**Note:** If adjusting the level with your camera mounted, first ensure the camera is securely held before loosening CLAMP NUT.

## 2. Camera Set-up

Please note that the best camera control can be achieved by balancing camera centre of gravity (C of G) over centre axis of the head, and by selecting the appropriate counterbalance position to suit the weight of the camcorder payload.

The DS5/DS10/DS20 is equipped with a sliding camera plate and a removable 1/4" -pin carriage which is standard mounting for DV and MiniDV camcorders. The DS20 is also fitted with a 3/8" & 1/4" screws which is standard mounting for DVCAM (see Fig 1.3).

The 3/8" & 1/4" screws also allow the DS20 to attach to a proprietary Quick Release Tripod Adaptor or "tripod base plate" such as the Sony VCT-14 or Panasonic SHAN-TM700.

- 2.1 Lock PAN and TILT LOCKS (rotate both levers clockwise until firm).
- 2.2 Remove CAMERA PLATE from CAMERA PLATFORM by unlocking the SLIDE LOCK, pushing SAFETY TAB and sliding the CAMERA PLATE rearward
- 2.3 With accessories and battery fitted to the camera, it is recommended to estimate the camera's Centre of Gravity (C of G) for the purpose of correctly positioning the camera on the CAMERA PLATE. The camera's C of G can be estimated by placing the camera on to a round rod and then shifting it backwards or forwards until a balance point - C of G - is achieved. It is recommended to identify this point as it will be useful in step 2.5.
- 2.4 Refer to the Camera's owners manual for correct method of attachment to the CAMERA PLATE. Attach the camera or the Quick Release Tripod Adaptor to the CAMERA PLATE and securely tighten the screws.
- 2.5 Check that the SLIDE LOCK is loose, then align the CAMERA PLATE with the CAMERA PLATFORM and slide it forward until the safety mechanism is engaged. Then, slide the CAMERA PLATE so that the camera's C of G is directly above the centre axis of the Fluid Head and tighten the SLIDE LOCK. If this can not be achieved then reposition the camera or the Quick Release Tripod Adaptor on the SLIDING PLATE - step 2.4. This will ensure that the system has maximum stability.

# Operating Instructions

## 3. Counterbalance Control

The counterbalance system was designed to neutralise the effect of the camera weight when it is tilted. The DS10 & DS20 Fluid Head offers a 2 position counterbalance system which can be operated via the COUNTERBALANCE SELECTOR (Fig. 2 & 3). The DS5 Fluid Head has a single position Counterbalance system and is preset. The COUNTERBALANCE SELECTOR must be operated when the SLIDING PLATFORM is in a horizontal position. After changing the Counterbalance setting it may be necessary to tilt the camera back and forth to ensure that the CB spring has engaged. The camera must be held securely while changing the Counterbalance setting.

- 3.1 For safety ensure that Counterbalance position 2 is selected.
- 3.2 Hold the camera and release the TILT LOCK, then gently tilt the camera from a horizontal position forward then backward and observe its response. If the Camera 'Springs Back' to the horizontal position then select Counterbalance position 1. Correct Counterbalance setting has been achieved when minimum effort is required to move the camera over the entire tilt range.

**TIP** Fine tuning can be achieved by adjusting the SLIDING PLATFORM - see step 2.5.



*Fig 2*  
DS10 CB Selector

## 4. Pan / Tilt Lock Control

The DS5/DS10/DS20 Fluid Head offers high capacity calliper disc brake system to hold the Fluid Head in a fixed pan and/or tilt position. Camera position will not change when applying or releasing the Pan / Tilt locks.

**WARNING:** Do not pan or tilt the Fluid Head whilst the PAN or the TILT LOCK is partially applied.



*Fig 3*  
DS20 CB Selector



## 5. Pan / Tilt Drag Control

5.1 The DS10/DS20 fluid head provides adjustment for tilt and pan drag control (Fig 4.). Rotate clockwise to engage friction resistance, anticlockwise to return to fluid action.

**Note:** The fluid drag plate system has been designed to suit most operating conditions. The friction drag adjustment should only be utilised when extra resistance is required.



**Fig 4**  
Drag  
control  
knobs

The DS5/DS10/DS20 fluid head features protective coatings, dust seals and anti-corrosive fittings to ensure long and trouble-free operation in extreme location conditions. To ensure optimum performance throughout the life of the head Miller recommends regular cleaning.

When the fluid head has been used in harsh environments (such as sand, mud or salt water spray), wipe over with a soft damp cloth as soon as possible. Use a soft brush to clean crevices. Remove and clean CAMERA PLATE.

**WARNING: Do not immerse a fluid head in any liquid.**

**WARNING: Do not use stiff brushes, abrasives or solvents.**

## Storage

When storing for extended periods: clean fluid head and place in a safe, dry place, away from direct sunlight. The fluid heads can be stored horizontally or upright. However, it is not advisable to leave the head for extended periods with the tilt locked in an extreme position, either forward or backward.

## Maintenance

With the exception of cleaning, the DS5/DS10/DS20 fluid head does not require additional maintenance. Miller recommends periodic servicing by a Miller Authorised Service Agent. Miller Authorised Service Agents must carry out all service and repair work. Failure to observe this requirement may void warranty.

# Technical Data

## Specifications - DS5/DS10/DS20 Fluid Head

Description	DS5 (#180)	DS10 (#182)	DS20( #184)
Weight - kg (lb)	1.6 (3.5)	1.7 (3.7)	1.75 (3.9)
Payload Range - kg (lb)	0.5 - 2.5 (1.1 - 5.5)	2.5 - 5.0 (5.5 - 11.0)	5.0 - 10.0 (11.1 - 22.0)
Pan/Tilt Drag	Fluid Drag plate system	Fluid Drag plate system with friction boost.	Fluid Drag plate system with friction boost.
Pan/Tilt Lock brake system	Calliper Disk Brake	Calliper Disk Brake	Calliper Disk Brake
Tilt Angle Range	+90°/-75°	+90°/-75°	+90°/-75°
Counterbalance System	Single Position	Two Position	Two Position
Position # 1 capacity - kg (lb)	Up to 2.5 (5.5)	Up to 2.5 (5.5)	2.5 - 5.0 (5.5 - 11.0)
Position # 2 capacity - kg (lb)	-	2.5 - 5.0 (5.5 - 11.0)	5.0 - 10.0 (11.0 - 22.0)
Camera Platform Type	Quick Release Sliding Camera Plate with 60 mm travel.	Quick Release Sliding Camera Plate with 60 mm travel.	Quick Release Sliding Camera Plate with 60 mm travel.
Camera Plate	Standard DS with 1/4" + Pin Adapter Carriage	Standard DS with 1/4" + Pin Adapter Carriage	Standard DS with 1/4" + Pin Adapter Carriage 1/4" and 3/8" screws
Bubble Level	Yes	Yes	Yes
Mounting Base	75 mm ball levelling	75 mm ball levelling	75 mm ball levelling
Handle	Standard Pan Handle	Standard Pan Handle	Standard Pan Handle
Temperature Range - °C (°F)	-40°/+65° (-40° / +149°)	-40°/+65° (-40° / +149°)	-40°/+65° (-40° / +149°)

## Spare Parts

### ITEM

DS5/DS10 Camera Plate (inc. #493 carriage)	#490
DS20 Camera Plate (inc. #493, 3/8" & 1/4" screws)	#489
1/4" – Pin carriage	#493
Camera Screw 1/4"	P0036
Camera Screw 3/8"	P0037
Fixed Length Pan Handle	#688
Fixed Length Pan Handle & clamp	#680
Pan Handle Clamp	P3436
Clamp Nut	P2321

## Warranty

Miller offers a comprehensive parts and labour warranty with all it's camera support products. For complete details please refer to the warranty card enclosed or contact your nearest Miller sales or service centre.

## Website [www.millertripods.com](http://www.millertripods.com)

For information about the complete range of Miller camera support products, or to find the address of your nearest authorised Miller sales centre, please visit our website at [www.millertripods.com](http://www.millertripods.com).

# MILLER

## Service, Sales & Support

Miller Authorised Service Agents must carry out all service and repair work. Failure to observe this requirement may void warranty. It is advisable to notify Miller or a Miller Authorised Service Agent if a change of performance is observed as a result of dropping or rough usage. For your nearest authorised Miller sales or service centre, please visit our website at [www.millertripods.com](http://www.millertripods.com).

### MILLER CAMERA SUPPORT (Australia)

30 Hotham Parade, Artarmon, Sydney  
NSW 2064 Australia  
Tel: +61 2 9439 6377  
Fax: +61 2 9438 2819  
Email: [sales@miller.com.au](mailto:sales@miller.com.au)

### MILLER CAMERA SUPPORT LLC (USA)

218 Little Falls Road, Cedar Grove  
New Jersey 07009-1231 USA  
Tel: (973) 857 8300  
Fax: (973) 857 8188  
Email: [sales@millertripods.us](mailto:sales@millertripods.us)

### MILLER FLUID HEADS (Europe) LTD.

Unit 12A, Shepperton Business Park  
Govett Avenue, Shepperton, Middlesex  
TW17 8BA United Kingdom  
Tel: +44 (0) 1932 222 888  
Fax: +44 (0) 1932 222 211  
Email: [sales@millertripods-europe.com](mailto:sales@millertripods-europe.com)