

### Conference Interface - Wideband Bridging

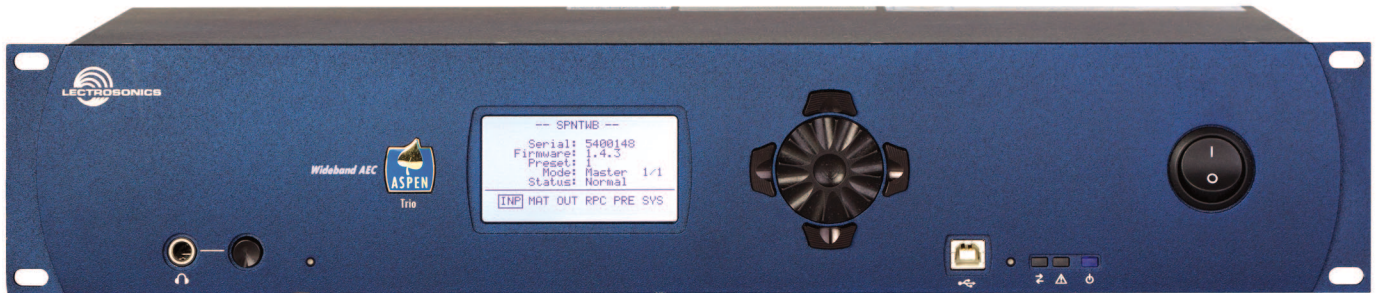

- Quad-reference Wideband Acoustic Echo Canceller supporting 3-way Bridging
- Two maximum speed grade, 4th generation SHARC® processors\*
- Dual Codec interfaces
- TCP/IP Ethernet Addressable
- Fully integrated with ASPEN digital matrix
- Adaptive Proportional Gain Automatic Mixing at the Matrix Crosspoints
- Third Octave Noise Filter on each channel
- Sigma-delta class-D audio power amplifiers
- Built-in 8 in/12 out ASPEN mixer with full signal processing on all inputs and outputs

The SPNTWB combines the boards from the SPN812 and the SPNCWB in a 2RU chassis to provide a complete, stand-alone component for telepresence and audio conference systems. The unit can be used with additional ASPEN processors to add additional inputs and outputs. Setup and adjustments can be made using the control panel software or the front panel LCD interface. Inputs and outputs appearing on the LCD have been consolidated into logical groups to simplify navigation.

The far end audio signals in a conference participate in the same manner as local microphones connected to the processor. Three sites connected via two codecs and a telephone line can be bridged into a single conference as seamlessly as local microphones.

The ASPEN AEC (acoustic echo canceller) provides new and advanced algorithms developed to address the need for a single acoustic echo canceller that could handle the challenges of multi-site bridging and an unlimited number of microphones. The AEC converges very quickly, then continues to increase the cancellation depth at every opportunity as a conference continues. Cancellation depth will increase even with brief signal peaks from the far end, and convergence will never be lost with any type of signal or in double talk situations.

The AEC in combination with the patented gain proportional mixing algorithm\* provides outstanding audio quality without echo heard at the far ends.

Signals from the far ends of the conference are routed to the local sound system also to a final mix that is used as a reference signal by the AEC. Audio from the local microphones (which includes far end audio from the local loudspeakers) is routed to the AEC via a second final mix for cancellation of the far end signals. After processing, the output of the AEC is routed back to the far ends through the matrix.

The proprietary noise reduction filter used in ASPEN processors is a third octave dynamic processor which is very effective when applied to the far end Codec and telephone line signals when poor connections occur.

An ethernet port is provided for setup and control via standard network connections, and an RS-232 port is provided for use with remote control systems. The design allows simultaneous, multi-point third party control.

A two channel power amplifier is included for loudspeakers in the local sound system. The power amplifier is driven by final mix outputs from the matrix and has a full set of signal processing, including parametric EQ, compressor and limiter. Class-D amplification is implemented with a late generation component that provides exceptional efficiency, low heat, excellent audio performance and cannot be damaged by wiring errors.



\*US Patents 5,414,776 and 5,402,500



# Signal Flow

The ASPEN matrix is common to all processors connected in the system. Processor boards are connected through a bidirectional 1Gbps bus which carries SubMix data and audio from Slaves to the Master (forward propagation). The Master unit gathers all of the SubMix audio and data and creates Final Mixes that are returned back to the Slaves through the bus (backward propagation).

Final Mixes provide the AEC with reference and local signals for acoustic echo cancellation, and deliver audio outputs to conference far end connections and the local sound system.

Master and Slave configurations are determined automatically according to the cable connections to the ASPEN port jacks on the rear panels.

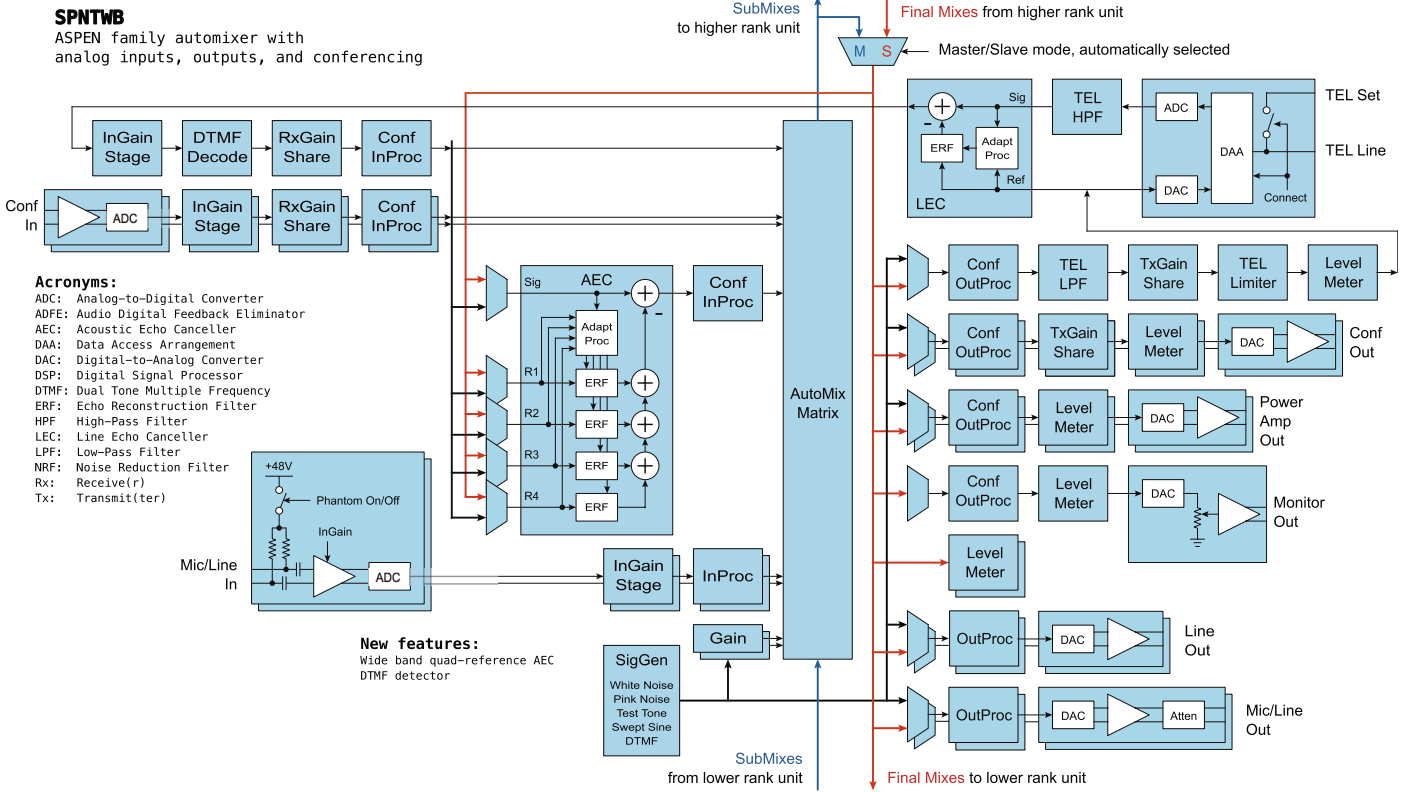

# Signal Processing

Each of the processing blocks shown above contains multiple elements as shown here:

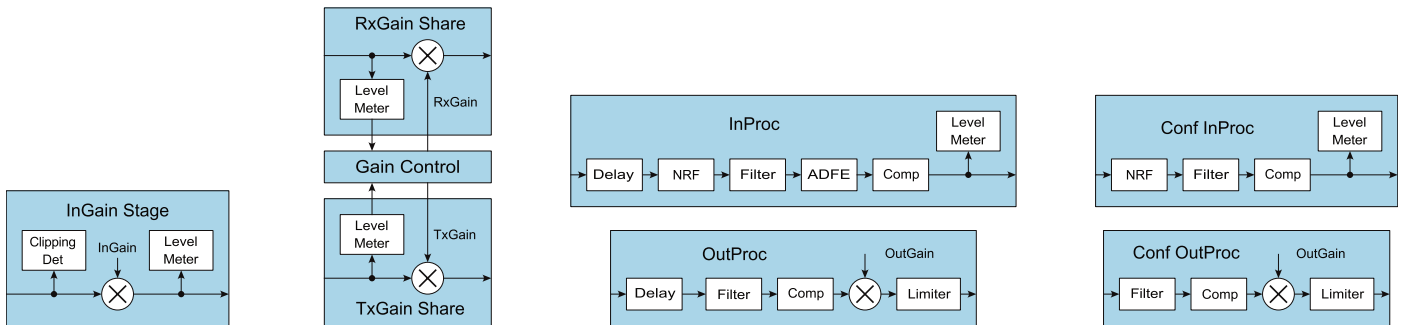

# Ports and Connections

Extensive control options are available through serial, ethernet, wired and logic ports.

- RS-232 is typically used with touch panel control systems.
- Ethernet connectivity allows remote access for setup and control with computer systems.
- Wired remote control with Lectrosonics desktop and wall mounted pushbutton panels is provided through two rear panel CAT-5 jacks.

- Hard wired control using pots, switches and LEDs connected to rear panel logic I/O ports allows direct control of levels, modes and indicators. In conjunction with the powerful, built-in macro language, these controls can be used for a wide variety of level adjustments, preset recalls, event triggered indicators, room combining configurations, etc.

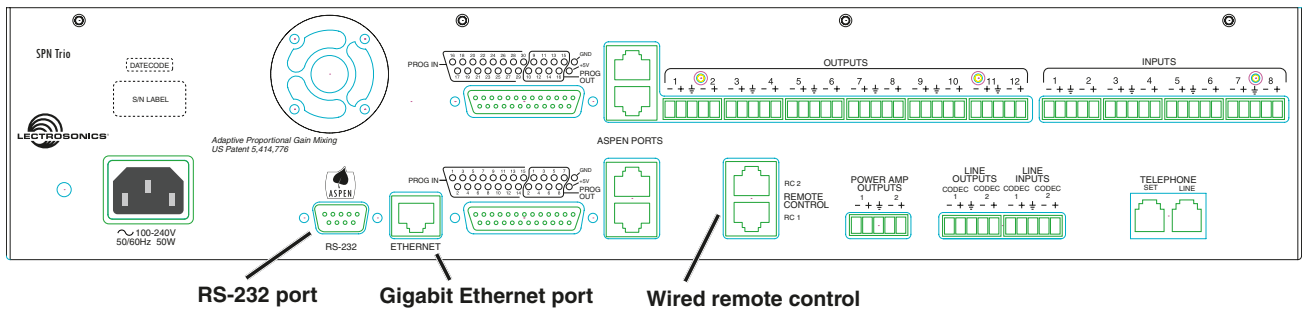
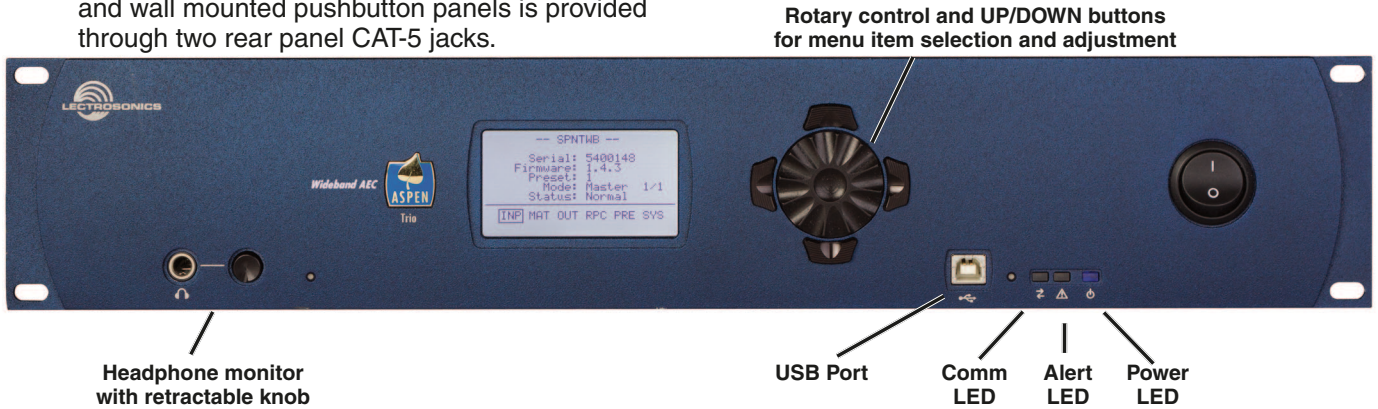

## Logic Output Connections

Potentiometers and switches can be connected to rear panel logic input controls to adjust levels or mute any one or a group of inputs, crosspoints and outputs. Logic outputs are used to drive LED indicators triggered by a variety of logic input activity and/or the status of inputs, presets and conference connections.

## Power Amp Outputs

The amplifier is designed to run continuously (idle or with a load) without heat buildup, making it ideal for permanent installations where prolonged operation is required.

Each output can drive a variety of loads, including loudspeakers, long cable runs and headphones. The BTL (bridge tied load) configuration allows the two channels to be wired in parallel on a common load to double the output power.

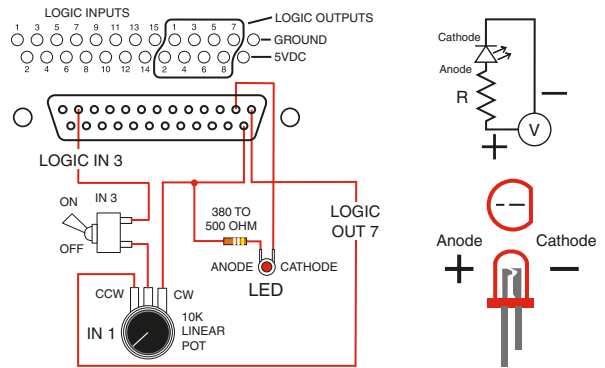

Logic I/O connections

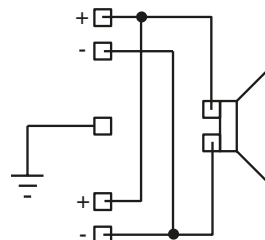

# Advanced Acoustic Echo Cancellation

Conventional AEC algorithms face a trade-off between convergence rate and depth. A fast convergence time adapts quickly when a new conversation begins or when a change occurs in the acoustic space, but the cancellation depth is limited. Deeper cancellation requires more time, so an echo may be heard at the far end until the AEC achieves a fairly deep convergence.

An ideal AEC would react very quickly in the beginning and then start applying more calculations over longer time intervals to achieve a deeper cancellation as the conference progresses.

The ideal echo canceller would also maintain convergence regardless of signal types or levels. This is precisely what the ASPEN echo canceller does. It is designed to handle multi-site bridging and any number of microphones simultaneously, and it works with the gain proportional mixing algorithm perfectly.

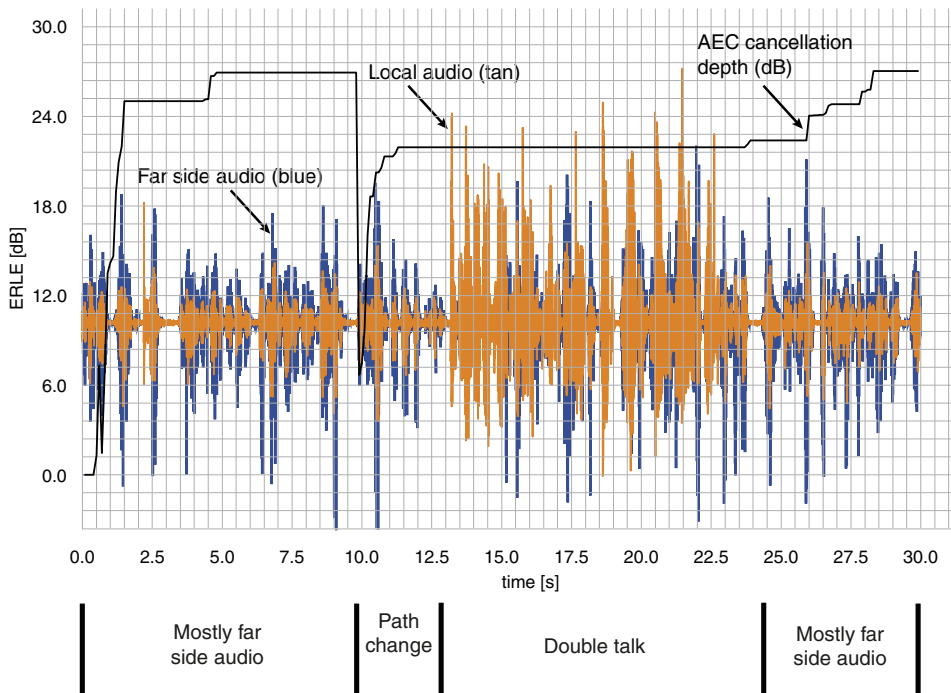

Example of AEC activity over a 30 second period.

An extremely difficult environment for an AEC is when local sound reinforcement is being used. Far side audio enters the local microphones and mixes with local audio and noise, which makes it extremely difficult for the AEC to identify and cancel the echo.

The example shown here is a 30 second recording of a conference with local and far side audio activity, plus a local sound reinforcement system.

0-1.5 seconds:

2-9.5 seconds:

At 10 seconds:

The AEC will not diverge (lose convergence) unless something changes in the local acoustic environment, such as a microphone moving. When this happens, it will converge again and adapt to the new echo path. These are usually very subtle changes and go completely unnoticed by the conference participants.



# Control Panel Software

ASPEN software is provided on disk with each processor and downloadable from the support web site. The package includes installers for USB Devices, the control panel GUI and a variety of documentation.

Readme - Release Notes

Install ASPEN Software

Install USB Drivers (32-bit)

Install USB Drivers (64-bit)

Lectrosonics on the Web

Contact Service and Support

Browse CD

Download Adobe Reader

Exit

**Bookshelf**

ASPEN Control Reference

SPN1624 Command Reference

SPN1616 Command Reference

SPNConference Command Reference

**Installation Guides**

ASPEN Mixers Install Guide

SPNConference Install Guide

**Technical Data Sheets**

ASPEN Mixers TD Sheet

SPNConference TD Sheet



*Manuals and data sheets require Adobe Acrobat Reader to be installed on your PC. If you do not have it, click on the "Download Adobe Reader" link to the left to get it.*

Lectrosonics, Inc. Phone: 800-821-1121  
 581 Laser Rd Fax: 505-892-6243  
 Rio Rancho, NM 87124 sales@lectrosonics.com

Control panels for the various processors open with a diagram of the processors in the order that they are connected through the rear panel ASPEN Ports.

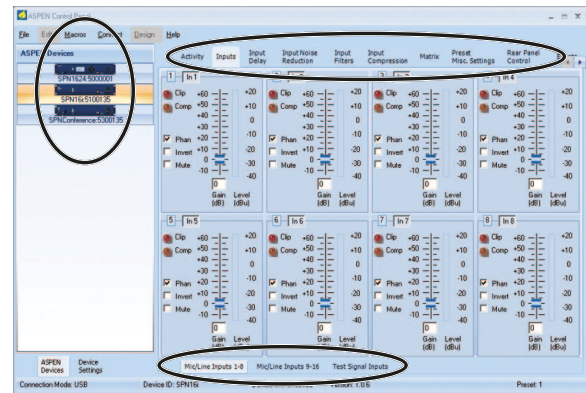

Tabs across the top and bottom of the panel open screens for each category of setup and configuration.

# Macros and the ASPEN Control Language

ASPEN macros are simply a series of instructions expressed using the ASPEN Control language. The elements of the control language are as follows.

## Commands

These are the familiar native commands of the ASPEN device, as documented in the “Command Set” in the reference manual or under the Control Panel Help menu. Ultimately, the purpose of the macro will be to issue commands to the device in order to make it “do” something, or to read out its current settings for use by external controllers.

## Variables

These are user defined global storage, used to pass data within a macro, or between macros. Variables make it possible for macros to have a “memory” of past actions, or to capture data for use within another macro, at some other time. Arithmetic, comparison, and logical operations can be performed with variables.

## Expressions

These are used to compute logical or arithmetical results using variables or constant values. Expressions make it possible to perform arithmetic, create loops, or make decisions using conditional statements.

## Loops

These are “while-do” statements of the sort seen in many other programming languages. Loops make it possible for a particular command to be run multiple times as long as the state of some device property or the value of some variable meets a specified condition.

## Conditionals

These are “if-then-else” statements of the sort seen in many other programming languages. Conditionals make it possible for a macro to choose between alternative actions on the basis of the current state of some device property or the value of some user defined variable.

Commands, loops and conditionals are statements, and can stand alone as a macro “line” or instruction. Variables and expressions play a supporting role, with variables commonly used in expressions and both often found in update commands as the “argument.” Loops and conditionals contain both expressions defining their “condition” and commands to be executed as their “actions” if the condition is met.

Macros may include up to 64 “lines,” each line containing one or more instructions, or statements. Multiple statements must be separated by a ‘;’ (semicolon) character. Loop and conditional statements may be combined. These maximum length of a macro line is 115 characters.

Macros are “run” (executed) in response to some triggering event, such as a serial command or the pressing of a push button connected to a programmable logic input pin. Applications such as room combining, courtroom sound systems, and teleconferencing rely on macros to make system setup changes “on the fly” in response to button panel activity or serial commands from 3rd party control systems.

Commands are used to control a variety of states and configurations such as:

- ADFE Filters
- Audio Inputs
- Input Compressors
- Input EQ filters
- Noise Reduction Filters
- Matrix Crosspoints
- Audio Outputs
- Output Compressors
- Output EQ Filters
- Output Limiters
- Rear Panel Control
- Programmable I/O
- Preset Management
- Macro Management
- RTC Timers and Alarms
- Internal Signal Generators
- Events
- Network Setup

# Multi-site Bridging

Conferencing requires a minimum of four mixes:

- AEC REFERENCE MIX
- AEC SIGNAL MIX
- SEND MIXES (includes the AEC output)
- LOCAL MIXES

The **AEC REFERENCE MIX** is a mix of all the local microphones which is routed through the AEC for echo cancellation before being sent to the far sides. We recommend that you use mix bus 48 for this mix.

The **AEC SIGNAL MIX** is a mix of all of the far side signals which is routed to the AEC to identify and cancel those that have entered the local microphones. We recommend that you use mix bus 47 for this mix.

The **SEND MIXES** consists of 3 elements:

- The AEC output (which is a mix of all the local microphones minus any echo caused by microphone/speaker coupling in the local room)
- Any other sources you want to send to the far end that are not microphones, such as program audio
- The far end signals you want to bridge to the other sites

A mix is assigned for each outbound signal. For example, if you have just a telephone line, you will only need one SEND mix for the *Tel Line Out*. If you have one phone and two Codecs, you will need three SEND mixes, one mix each for the *Tel Line Out*, *Codec 1 Out* and *Codec 2 Out*. We recommend you use the mix buses 46, 45, 44, etc. for these signal mixes.

The **LOCAL MIX** includes the far end signals, program audio, and any local microphones that require amplification. Mix-minus routing can be created using multiple crosspoints to improve gain-before-feedback in the local sound system. We recommend that you use mix busses 1, 2, 3, etc. for these mixes to keep them well separated in the matrix from the mixes used for conference connections. There is no technical or performance reason for this separation; it simply makes it easier to visualize the matrix assignments during setup.

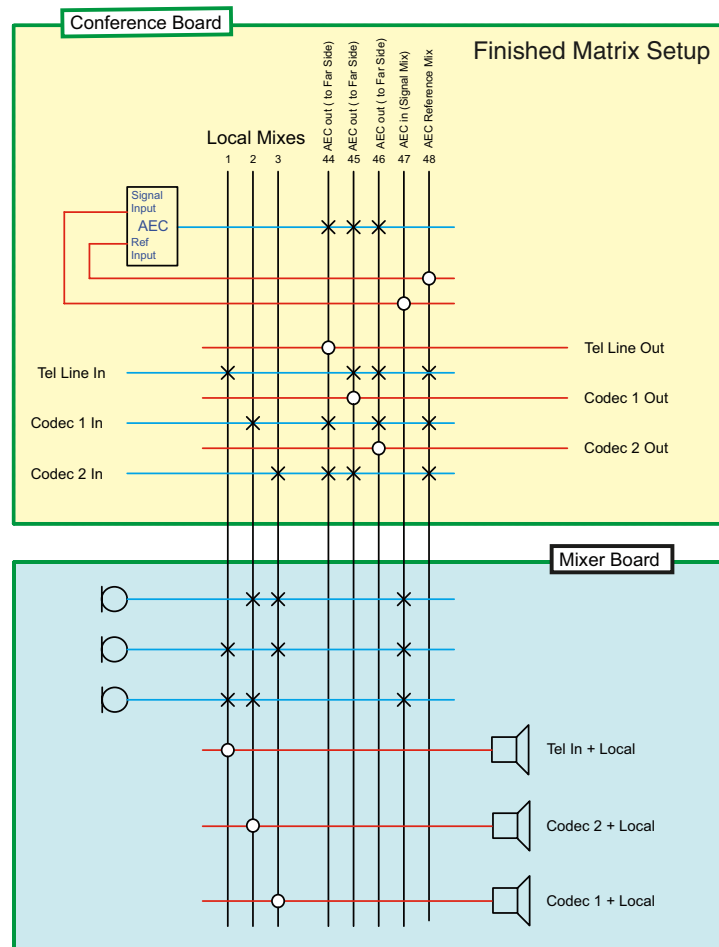

- × Signal added to mix (matrix)
- Mixes for output signals (outsourse)

# Specifications

## Mic/Line Inputs:

All inputs are digitally programmable-gain microphone to line level differential inputs. Either side can be grounded or left floating. The cable shield shall be connected to ground

Max. input level:	20 dBu
Gain:	0 dB to 56 dB, programmable in 8 dB steps (the analog gain is automatically selected by selecting the input gain)
Input impedance:	8 k $\Omega$ differential mode, 2 k $\Omega$ common mode
Phantom voltage:	48 V
Dynamic range:	102 dB
EIN:	-127 dBu (20Hz – 20kHz, unweighted)
THD + noise:	0.01%

## Line Outputs:

All outputs are floating transformerless differential outputs. Either side can be grounded or left floating. The cable shield shall be connected to ground.

Nominal level:	0 dBu, channels 1-8 0 dBu, -20 dBu, -40 dBu, channels 9-12
Headroom:	20 dB
Output impedance:	< 50 $\Omega$ , all outputs, at all attenuator settings
Dynamic range:	105 dB
THD + noise:	0.01%

## Filters:

All filters, including the noise reduction filter (NRF), have zero processing delay.

Noise reduction filters:	Adjustable 6 to 35 dB on every input
Tone control stages:	4 per input channel
Parametric EQ stages:	8 per output channel
ADFE:	8 per input channel (configurable as Static or Dynamic)

## Dynamic

### Filter types:

Low Pass:	Butterworth (6, 12, 18, 24 dB/octave) Bessel (6, 12, 18, 24 dB/octave) Linkwitz-Riley (12, 24 dB/octave) Additional parameters: frequency [Hz]
High Pass:	Butterworth (6, 12, 18, 24 dB/octave) Bessel (6, 12, 18, 24 dB/octave) Linkwitz-Riley (12, 24 dB/octave) Additional parameters: frequency [Hz]
Low Shelving:	Butterworth (6, 12, 18, 24 dB/octave) Bessel (6, 12, 18, 24 dB/octave) Additional parameters: frequency [Hz] boost/cut [dB]
High Shelving:	Butterworth (6, 12, 18, 24 dB/octave) Bessel (6, 12, 18, 24 dB/octave) Additional parameters: frequency [Hz] boost/cut [dB]
Peaking EQ (parametric):	frequency [Hz] bandwidth [octave] boost/cut [dB]

## Internal Signal Generator:

White noise:	level [dBu]
Pink noise:	level [dBu]
Tone (sine wave):	level [dBu] frequency [Hz]
Swept sine:	single sweep continuous sweep
Sweep Waveform:	sawtooth (up or down) triangle
Sweep rate:	linear logarithmic
Sweep Parameters:	start frequency [Hz] stop frequency [Hz] level [dBu] sweep time [sec]

## Latency:

Single-board:	64 audio samples = 1.333 ms
System:	1.333 ms (Master) + .125 ms for each Slave
board	
Example:	2.958 ms for 192 inputs with 48 outputs (system with

## Acoustic Echo Canceller:

AEC Tail Time: Centralized, bridgeable for Telepresence

AEC Tail Time:	128 ms tail time - will never diverge, regardless of signal type (i.e. sine wave)
Line EC Tail Time:	48 ms tail time
AEC Bandwidth:	10 kHz
Telephone Hybrid Return Loss:	26 dB + line echo canceller = 45 dB
Audio inputs (Codec):	
Gain:	-20 dB to +20 dB, programmable in 1 dB steps
Input impedance:	15k ohm (differential); 375k (common)
Connector:	5-pin Phoenix
Audio outputs (Codec):	Floating balanced
Nominal level:	0 dBu
Output impedance:	50 $\Omega$
Speaker outputs:	(2) 10W, class D, BTL wiring to double power
Mic/line outputs:	1-8 line level (0dBu), 9-12 mic/line level (0, -20, -40dBu)

## Input Dynamic Range (Codec):

102 dB (unweighted 20 - 20 kHz)

## Output Dynamic Range (Codec):

105 dB (unweighted 20 - 20 kHz)

## Audio Performance (Codec):

THD + noise: 0.01%

## Front Panel Connectors:

control

## Rear Panel Connectors:

Power:	IEC 60320 C14
RS-232:	DB-9
Ethernet:	RJ-45
Programmable Logic I/O:	(2) DB-25
ASPEN port:	(2) Dual RJ-45
Remote control:	Dual RJ-45
Power amp output:	5-pin Phoenix
Mic/Line Inputs/Line Outputs:	(12) 5-pin Phoenix
Telephone Set/Line:	Dual RJ-11

## Proprietary network:

Physical level:	LVDS (Low Voltage Differential Signal) high speed CAT-6 1 Gbps
Cable type:	
Transmission speed:	

## Programmable control inputs:

Number of inputs:	30
Analog voltage range:	0-5V
Logic input:	TTL, LVTTTL, CMOS, LVCMOS

## Programmable control outputs:

Number of logic outputs:	16
Logic control:	active low
Max sink current:	100 mA
Max supply voltage:	40 V
Supply voltage for control I/O:	5 V
Max current:	750 mA

## Cabled Remote Controls:

Codec 1: Lectrosionics RCWTH4; RJ-45 jack

Tel: Lectrosionics RCWTH4; RJ-45 jack

100-240 VAC, 50/60 Hz

50 Watts

## Dimensions:

Faceplate: Standard 19 inch 2RU

Housing (WxHxD): 17.50 x 3.50 x 7.25 inches

Weight: 5.65 lbs. (without AC cord)

