

Wideband Bridging Conference Interface



- **Quad-reference Wideband Acoustic Echo Canceller supporting 3-way Bridging**
- **Two maximum speed grade, 4th generation SHARC® processors***
- **Dual Codec interfaces**
- **TCP/IP Ethernet Addressable**
- **Fully integrated with ASPEN digital matrix**
- **Adaptive Proportional Gain Automatic Mixing at the Matrix Crosspoints**
- **Third Octave Noise Filter on each channel**
- **Sigma-delta class-D audio power amplifiers**

The SPNCWB wideband conference interface makes telepresence and multi-site bridging simple and effective in any conference room, with full bandwidth audio frequency response and a unique Quad-reference AEC. Each conference connection includes a dedicated AEC for fast and reliable echo cancellation:

- Telephone line (POTS)
- Codec 1
- Codec 2

The fourth AEC is assignable to any final mix in the matrix for purposes such as noise cancellation (when fed a signal from a sampling microphone).

The AEC converges very fast and will remain converged during double-talk and any signal type, including sine waves, enabled by an advanced DSP algorithm. Cancellation depth increases with even with brief signal peaks from the far ends.

The AEC in combination with the patented proportional gain mixing algorithm (*US Patents 5,414,776 and 5,402,500*) provides outstanding audio quality without echo heard at the far ends. Signals from the far ends of the conference are routed to the local sound system and to three mixes that are used as reference signals by the AEC. Audio from the local microphones (which includes far end audio delivered by local loudspeakers) is routed to the AEC via another final mix for cancellation of the far end signals. After processing, the output of the AEC is routed back to the far ends through the matrix.

Three remote sites can be bridged with a local sound system for a seamless telepresence or audio conference. The far end audio signals participate in the same manner as local microphones connected to the mixer.

A full complement of audio signal processing is provided for all inputs and outputs. In addition, a proprietary NRF (noise reduction filter) is provided on each input to suppress noise in severe conditions. The NRF employs a proprietary noise reduction algorithm using a 1/3 octave analysis and downward expansion. The amount of noise reduction applied to the signal at each input is adjustable from 6 dB to 35 dB as needed for the signal conditions and individual preferences. The process is very effective, with almost no audible artifacts up to about 18 dB. Higher values are available for very poor conditions where noise is extremely high and intelligibility is improved at the expense of artifacts in the audio.

A two channel power amplifier is included for loudspeakers in the local sound system. The power amplifier is driven by final mix outputs from the matrix and has a full set of signal processing, including delay, parametric EQ, compressor and limiter. Class-D amplification with a late generation component provides exceptional efficiency, low heat and excellent audio performance. The amplifiers cannot be damaged by wiring errors or unusual loads.

The processor interconnects with other ASPEN processors via the 1Gbps bus built into all models.



* SHARC is a registered trademark of Analog Devices, Inc.



Signal Flow

Two Codec interfaces and a telephone line are processed and delivered to the ASPEN matrix in the same manner as microphones are handled in an ASPEN mixer. Four additional *Virtual* inputs receive signals from a built-in signal generator, which is used for testing and diagnostics.

The AEC receives signals from two final mixes that supply far end and local audio signals needed for echo cancellation. The AEC output after cancellation is then routed through the matrix to the appropriate Codec and telephone line outputs.

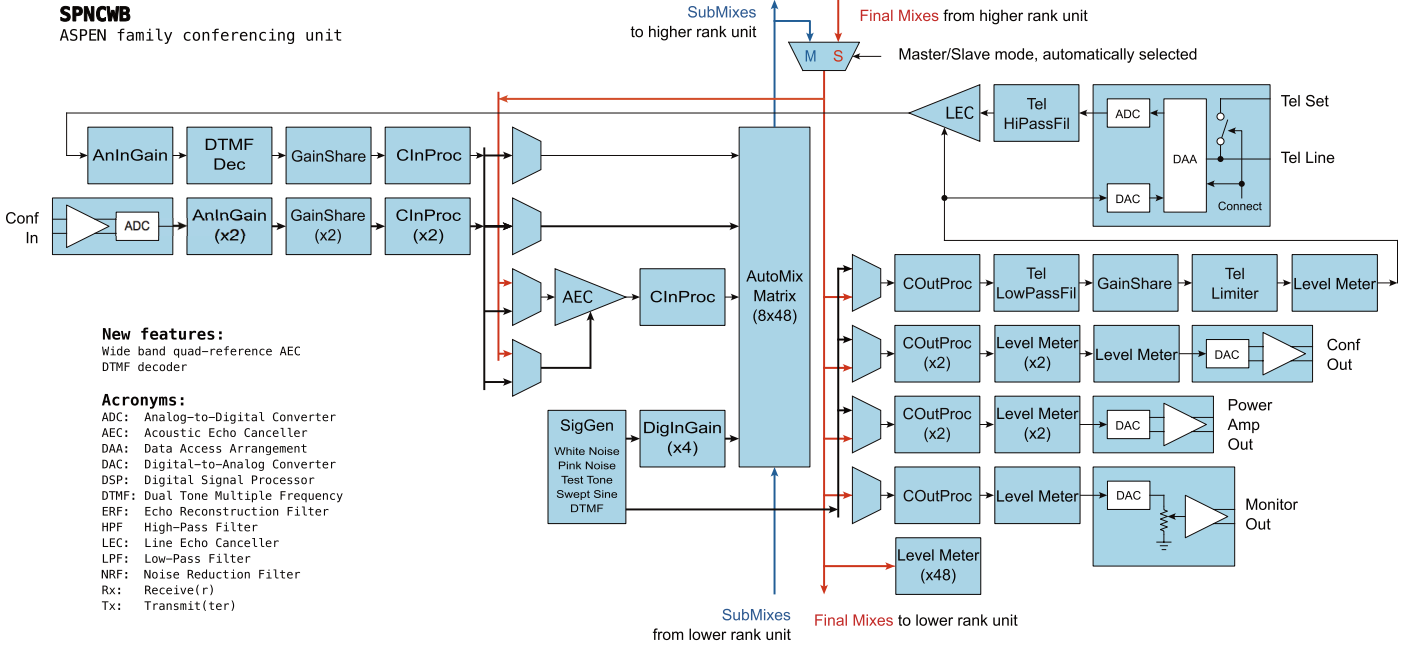

Signal Processing

Each of the processing blocks shown above contains multiple elements as shown here:

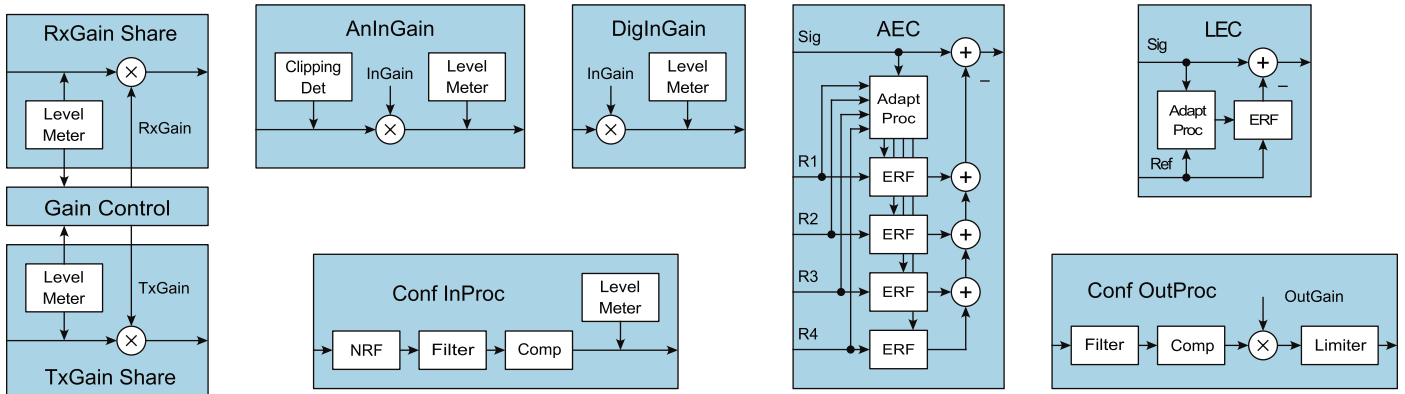

Ports and Connections

Extensive control options are available through serial, ethernet, wired and logic ports.

- RS-232 is typically used with touch panel control systems.
- Ethernet connectivity allows remote access for setup and control with computer systems.
- Wired remote control with Lectrosonics desktop and wall mounted pushbutton panels is provided through two rear panel CAT-5 jacks.

- Hard wired control using pots, switches and LEDs connected to rear panel logic I/O ports allows direct control of levels, modes and indicators. In conjunction with the powerful, built-in macro language, these controls can be used for a wide variety of level adjustments, preset recalls, event triggered indicators, room combining configurations, etc.

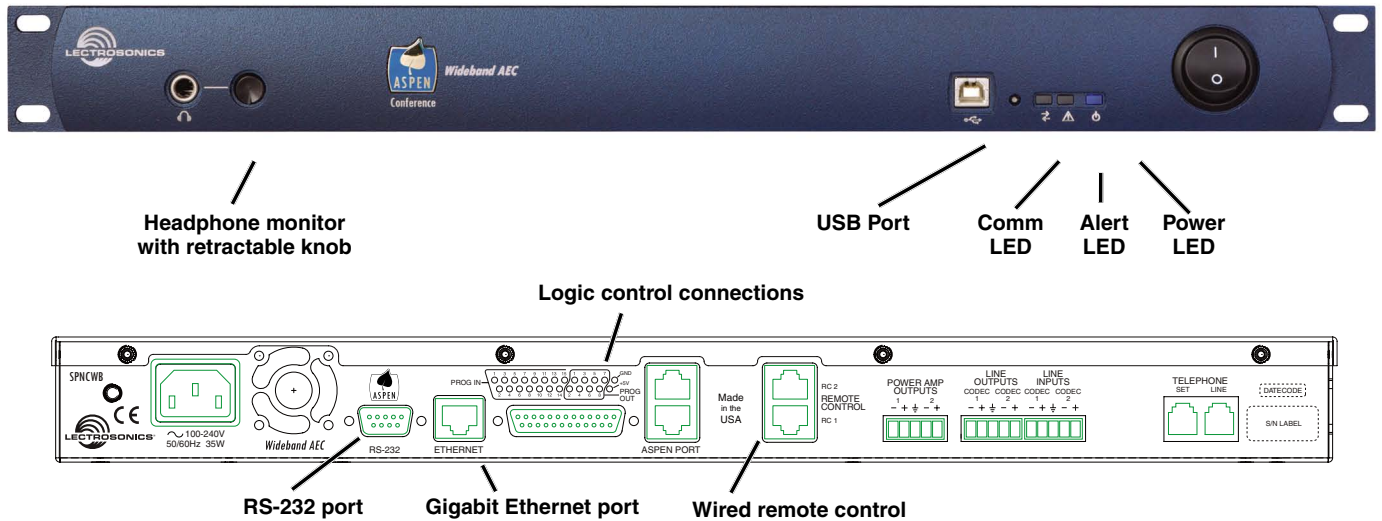

Logic Output Connections

Potentiometers and switches can be connected to rear panel logic input controls to adjust levels or mute any one or a group of inputs, crosspoints and outputs. Logic outputs are used to drive LED indicators triggered by a variety of logic input activity and/or the status of inputs, presets and conference connections.

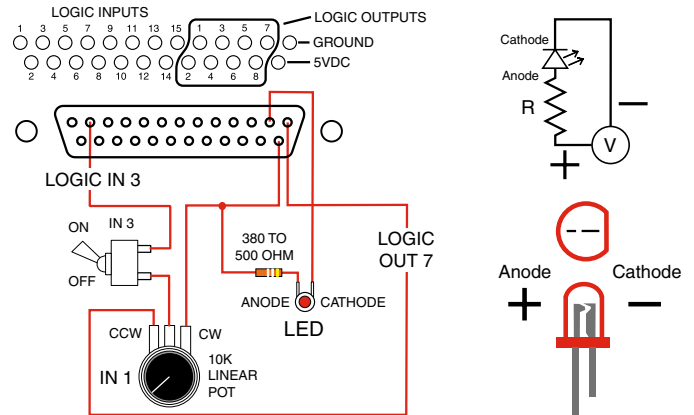

Logic I/O connections

Power Amp Outputs

The amplifier is designed to run continuously (idle or with a load) without heat buildup, making it ideal for permanent installations where prolonged operation is required.

Each output can drive a variety of loads, including loudspeakers, long cable runs and headphones. The BTL (bridge tied load) configuration allows the two channels to be wired in parallel on a common load to double the output power.

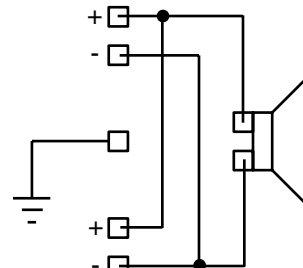

BTL output wiring

Advanced Acoustic Echo Cancellation

Conventional AEC algorithms face a trade-off between convergence rate and depth. A fast convergence time adapts quickly when a new conversation begins or when a change occurs in the acoustic space, but the cancellation depth is limited. Deeper cancellation requires more time, so an echo may be heard at the far end until the AEC achieves a fairly deep convergence.

An ideal AEC would react very quickly in the beginning and then start applying more calculations over longer time intervals to achieve a deeper cancellation as the conference progresses.

The ideal echo canceller would also maintain convergence regardless of signal types or levels. This is precisely what the ASPEN echo canceller does. It is designed to handle multi-site bridging and any number of microphones simultaneously, and it works with the gain proportional mixing algorithm perfectly.

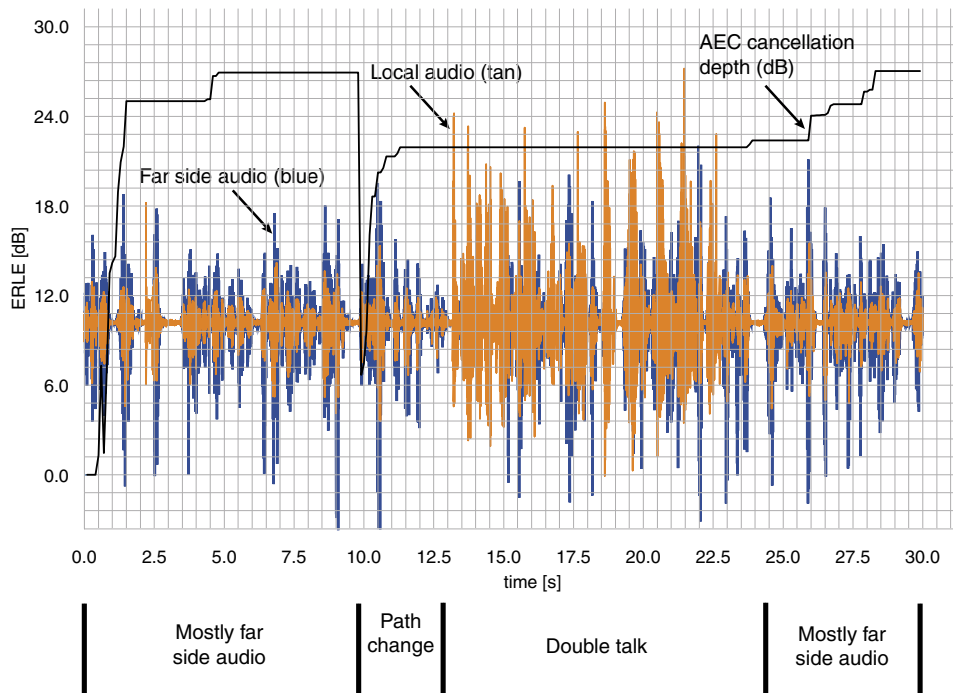

Example of AEC activity over a 30 second period.

An extremely difficult environment for an AEC is when local sound reinforcement is being used. Far side audio enters the local microphones and mixes with local audio and noise, which makes it extremely difficult for the AEC to identify and cancel the echo.

The example shown here is a 30 second recording of a conference with local and far side audio activity, plus a local sound reinforcement system.

0-1.5 seconds:

2-9.5 seconds:

At 10 seconds:

The AEC will not diverge (lose convergence) unless something changes in the local acoustic environment, such as a microphone moving. When this happens, it will converge again and adapt to the new echo path. These are usually very subtle changes and go completely unnoticed by the conference participants.

Control Panel Software

ASPEN software is provided on disk with each processor and downloadable from the support web site. The package includes installers for USB Devices, the control panel GUI and a variety of documentation.

<p>Readme - Release Notes</p> <p>Install ASPEN Software</p> <p>Install USB Drivers (32-bit)</p> <p>Install USB Drivers (64-bit)</p> <p>Lectrosonics on the Web</p> <p>Contact Service and Support</p> <p>Browse CD</p> <p>Download Adobe Reader</p> <p>Exit</p>	<p>Bookshelf</p> <p>ASPEN Control Reference</p> <p>SPN1624 Command Reference</p> <p>SPN16i Command Reference</p> <p>SPNConference Command Reference</p>	<p>Installation Guides</p> <p>ASPEN Mixers Install Guide</p> <p>SPNConference Install Guide</p>	<p>Technical Data Sheets</p> <p>ASPEN Mixers TD Sheet</p> <p>SPNConference TD Sheet</p>
---	--	--	--

Manuals and data sheets require Adobe Acrobat Reader to be installed on your PC. If you do not have it, click on the "Download-Adobe Reader" link to the left to get it.



Lectrosonics, Inc. Phone: 800-821-1121
 581 Laser Rd Fax: 505-692-6243
 Rio Rancho, NM 87124 sales@lectrosonics.com

Control panels for the various processors open with a diagram of the processors in the order that they are connected through the rear panel ASPEN Ports.

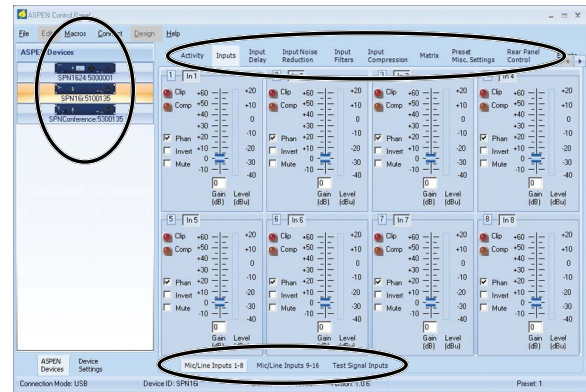

Tabs across the top and bottom of the panel open screens for each category of setup and configuration.

Macros and the ASPEN Control Language

ASPEN macros are simply a series of instructions expressed using the ASPEN Control language. The elements of the control language are as follows.

Commands

These are the familiar native commands of the ASPEN device, as documented in the “Command Set” in the reference manual or under the Control Panel Help menu. Ultimately, the purpose of the macro will be to issue commands to the device in order to make it “do” something, or to read out its current settings for use by external controllers.

Variables

These are user defined global storage, used to pass data within a macro, or between macros. Variables make it possible for macros to have a “memory” of past actions, or to capture data for use within another macro, at some other time. Arithmetic, comparison, and logical operations can be performed with variables.

Expressions

These are used to compute logical or arithmetical results using variables or constant values. Expressions make it possible to perform arithmetic, create loops, or make decisions using conditional statements.

Loops

These are “while-do” statements of the sort seen in many other programming languages. Loops make it possible for a particular command to be run multiple times as long as the state of some device property or the value of some variable meets a specified condition.

Conditionals

These are “if-then-else” statements of the sort seen in many other programming languages. Conditionals make it possible for a macro to choose between alternative actions on the basis of the current state of some device property or the value of some user defined variable.

Commands, loops and conditionals are statements, and can stand alone as a macro “line” or instruction. Variables and expressions play a supporting role, with variables commonly used in expressions and both often found in update commands as the “argument.” Loops and conditionals contain both expressions defining their “condition” and commands to be executed as their “actions” if the condition is met.

Macros may include up to 64 “lines,” each line containing one or more instructions, or statements. Multiple statements must be separated by a ‘;’ (semicolon) character. Loop and conditional statements may be combined. These maximum length of a macro line is 115 characters.

Macros are “run” (executed) in response to some triggering event, such as a serial command or the pressing of a push button connected to a programmable logic input pin. Applications such as room combining, courtroom sound systems, and teleconferencing rely on macros to make system setup changes “on the fly” in response to button panel activity or serial commands from 3rd party control systems.

Commands are used to control a variety of states and configurations such as:

- ADFE Filters
- Audio Inputs
- Input Compressors
- Input EQ filters
- Noise Reduction Filters
- Matrix Crosspoints
- Audio Outputs
- Output Compressors
- Output EQ Filters
- Output Limiters
- Rear Panel Control
- Programmable I/O
- Preset Management
- Macro Management
- RTC Timers and Alarms
- Internal Signal Generators
- Events
- Network Setup

Multi-site Bridging

With the addition of an ASPEN mixer, multiple far sides can be connected to each other and the local site using a mix-minus approach.

Conferencing requires a minimum of four mixes:

- AEC REFERENCE MIX
- AEC SIGNAL MIX
- SEND MIXES (includes the AEC output)
- LOCAL MIXES

The **AEC REFERENCE MIX** is a mix of all the local microphones which is routed through the AEC for echo cancellation before being sent to the far sides. We recommend that you use mix bus 48 for this mix.

The **AEC SIGNAL MIX** is a mix of all of the far side signals which is routed to the AEC to identify and cancel those that have entered the local microphones. We recommend that you use mix bus 47 for this mix.

The **SEND MIXES** consists of 3 elements:

- The AEC output (which is a mix of all the local microphones minus any echo caused by microphone/speaker coupling in the local room)
- Any other sources you want to send to the far end that are not microphones, such as program audio
- The far end signals you want to bridge to the other sites

A mix is assigned for each outbound signal. For example, if you have just a telephone line, you will only need one SEND mix for the *Tel Line Out*. If you have one phone and two Codecs, you will need three SEND mixes, one mix each for the *Tel Line Out*, *Codec 1 Out* and *Codec 2 Out*. We recommend you use the mix busses 46, 45, 44, etc. for these signal mixes.

The **LOCAL MIX** includes the far end signals, program audio, and any local microphones that require amplification. Mix-minus routing can be created using multiple crosspoints to improve gain-before-feedback in the local sound system. We recommend that you use mix busses 1, 2, 3, etc. for these mixes to keep them well separated in the matrix from the mixes used for conference connections. There is no technical or performance reason for this separation; it simply makes it easier to visualize the matrix assignments during setup.

SPNCWB Conference Processor

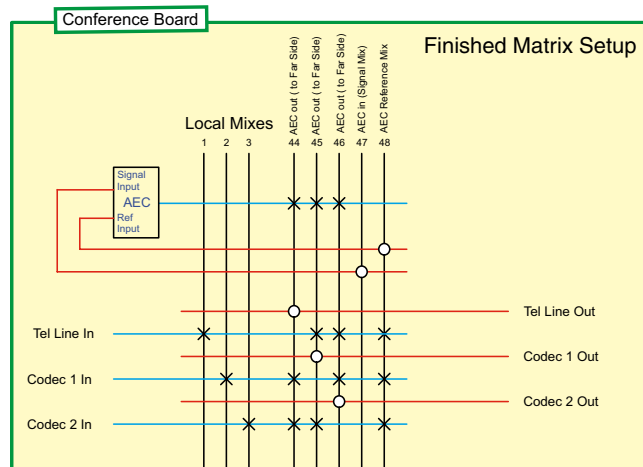

ASPEN Mixer such as the SPN812

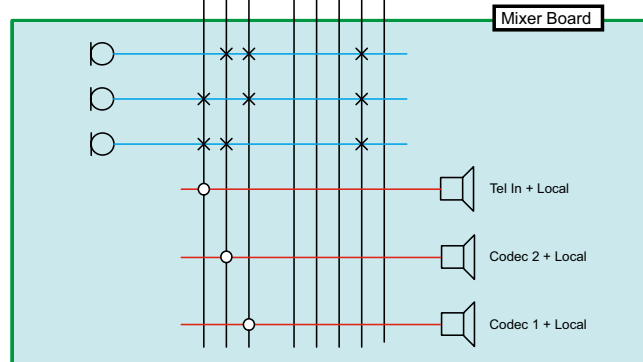

X Signal added to mix (matrix)

O Mixes for output signals (outsources)

Specifications

Acoustic Echo Canceller:	128 ms tail time - will never diverge, regardless of signal type (i.e. sine wave)	Number of inputs:	15
Line Echo Canceller:	48 ms tail time	Analog voltage range:	0-5V
Telephone Hybrid Return Loss:	26 dB + line echo canceller = 45 dB	Logic input:	TTL, LVTTTL, CMOS, LVCMOS
Audio inputs (Codec):		Programmable control outputs	
Gain:	-20 dB to +20 dB, programmable in 1 dB steps	Number of logic outputs:	8
Input impedance:	15k ohm (differential); 375k (common)	Logic control:	active low
Connector:	5-pin Phoenix	Max sink current:	100 mA
Audio outputs (Codec):	Floating balanced	Max supply voltage:	40 V
Nominal level:	0 dBu	Supply voltage for control I/O:	5 V
Output impedance:	50 Ω	Max current:	750 mA
Input Dynamic Range (Codec):	102 dB (unweighted 20 - 20 kHz)	Cabled Remote Controls:	Codec 1: Lectrosonics RCWTH4; RJ-45 jack Tel: Lectrosonics RCWTH4; RJ-45 jack
Output Dynamic Range (Codec):	105 dB (unweighted 20 - 20 kHz)	Power requirements:	100-240 VAC, 50/60 Hz
Audio Performance (Codec):		Power consumption:	15 Watts
THD + noise:	0.01%	Dimensions:	
Front Panel Connectors:	<ul style="list-style-type: none">• 1/4 inch headphone monitor jack with level control• Standard USB	Faceplate:	Standard 19 inch 1RU
Rear Panel Connectors:		Housing (WxHxD):	17.50 x 1.72 x 7.25 inches
Power:	IEC 60320 C14	Weight:	3.56 lbs. (without AC cord)
RS-232:	DB-9		
Ethernet:	RJ-45		
Programmable Logic I/O:	DB-25		
ASPEN port:	Dual RJ-45		
Remote control:	Dual RJ-45		
Power amp output:	5-pin Phoenix		
Line Inputs/Outputs:	(2) 5-pin Phoenix		
Telephone Set/Line:	(2) RJ-11		
Proprietary network			
Physical level:	LVDS (Low Voltage Differential Signal) high speed		
Cable type:	CAT-6		
Transmission speed:	1 Gbps		
Programmable control inputs			

