

# LCD Monitor

## Operating Instructions

Before operating the unit, please read this manual thoroughly and retain it for future reference.

LMD-2341W

LMD-2041W

LMD-1541W

**HDMI™**  
HIGH-DEFINITION MULTIMEDIA INTERFACE

## Owner's Record

The model and serial numbers are located at the rear. Record these numbers in the spaces provided below. Refer to these numbers whenever you call upon your Sony dealer regarding this product.

Model No. \_\_\_\_\_

Serial No. \_\_\_\_\_

### Important Safety Instructions

- Read these instructions.
- Keep these instructions.
- Heed all warnings.
- Follow all instructions.
- Do not use this apparatus near water.
- Clean only with dry cloth.
- Do not block any ventilation openings. Install in accordance with the manufacturer's instructions.
- Do not install near any heat sources such as radiators, heat registers, stoves, or other apparatus (including amplifiers) that produce heat.
- Do not defeat the safety purpose of the polarized or grounding-type plug. A polarized plug has two blades with one wider than the other. A grounding-type plug has two blades and a third grounding prong. The wide blade or the third prong are provided for your safety. If the provided plug does not fit into your outlet, consult an electrician for replacement of the obsolete outlet.
- Protect the power cord from being walked on or pinched particularly at plugs, convenience receptacles, and the point where they exit from the apparatus.
- Only use attachments/accessories specified by the manufacturer.
- Use only with the cart, stand, tripod, bracket, or table specified by the manufacturer, or sold with the apparatus.  When a cart is used, use caution when moving the cart/apparatus combination to avoid injury from tip-over.
- Unplug this apparatus during lightning storms or when unused for long periods of time.
- Refer all servicing to qualified service personnel. Servicing is required when the apparatus has been damaged in any way, such as power-supply cord or plug is damaged, liquid has been spilled or objects have fallen into the apparatus, the apparatus has been exposed to rain or moisture, does not operate normally, or has been dropped.

## WARNING

**To reduce the risk of fire or electric shock, do not expose this apparatus to rain or moisture.**

**To avoid electrical shock, do not open the cabinet. Refer servicing to qualified personnel only.**

## WARNING THIS APPARATUS MUST BE EARTHED.

### WARNING

When installing the unit, incorporate a readily accessible disconnect device in the fixed wiring, or connect the power plug to an easily accessible socket-outlet near the unit. If a fault should occur during operation of the unit, operate the disconnect device to switch the power supply off, or disconnect the power plug.

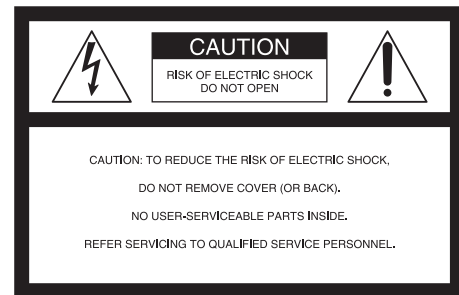

This symbol is intended to alert the user to the presence of uninsulated “dangerous voltage” within the product’s enclosure that may be of sufficient magnitude to constitute a risk of electric shock to persons.



This symbol is intended to alert the user to the presence of important operating and maintenance (servicing) instructions in the literature accompanying the appliance.

### Attention-when the product is installed in Rack:

#### 1. Prevention against overloading of branch circuit

When this product is installed in a rack and is supplied power from an outlet on the rack, please make sure that the rack does not overload the supply circuit.

#### 2. Providing protective earth

When this product is installed in a rack and is supplied power from an outlet on the rack, please confirm that the outlet is provided with a suitable protective earth connection.

### **3. Internal air ambient temperature of the rack**

When this product is installed in a rack, please make sure that the internal air ambient temperature of the rack is within the specified limit of this product.

### **4. Prevention against achieving hazardous condition due to uneven mechanical loading**

When this product is installed in a rack, please make sure that the rack does not achieve hazardous condition due to uneven mechanical loading.

### **5. Install the equipment while taking the operating temperature of the equipment into consideration**

For the operating temperature of the equipment, refer to the specifications of the Operation Manual.

### **6. When performing the installation, keep the following space away from walls in order to obtain proper exhaust and radiation of heat.**

**Upper and lower : 4.4 cm (1 3/4 inches) or more**

**Rear : 10.0 cm (4 inches) or more**

#### **CAUTION**

This LCD monitor should only be used with a specified monitor stand. For information on suitable stands, refer to "Specifications." Installation of the LCD monitor on any other stand may result in instability, possibly leading to injury.

#### **CAUTION**

The apparatus shall not be exposed to dripping or splashing. No objects filled with liquids, such as vases, shall be placed on the apparatus.

#### **CAUTION**

The unit is not disconnected from the AC power source (mains) as long as it is connected to the wall outlet, even if the unit itself has been turned off.

#### **WARNING**

Excessive sound pressure from earphones and headphones can cause hearing loss.

In order to use this product safely, avoid prolonged listening at excessive sound pressure levels.

#### **For the customers in the U.S.A.**

This equipment has been tested and found to comply with the limits for a Class A digital device, pursuant to Part 15 of the FCC Rules. These limits are designed to provide reasonable protection against harmful interference when the equipment is operated in a commercial environment. This equipment generates, uses, and can radiate radio frequency energy and, if not installed and used in accordance with the instruction manual, may cause harmful interference to radio

communications. Operation of this equipment in a residential area is likely to cause harmful interference in which case the user will be required to correct the interference at his own expense.

You are cautioned that any changes or modifications not expressly approved in this manual could void your authority to operate this equipment.

All interface cables used to connect peripherals must be shielded in order to comply with the limits for a digital device pursuant to Subpart B of Part 15 of FCC Rules.

This device complies with Part 15 of the FCC Rules. Operation is subject to the following two conditions: (1) this device may not cause harmful interference, and (2) this device must accept any interference received, including interference that may cause undesired operation.

#### **WARNING:**

Using this unit at a voltage other than 120 V may require the use of a different line cord or attachment plug, or both. To reduce the risk of fire or electric shock, refer servicing to qualified service personnel.

#### **For the customers in Canada**

This Class A digital apparatus complies with Canadian ICES-003.

#### **For the customers in Europe**

This product with the CE marking complies with the EMC Directive issued by the Commission of the European Community.

Compliance with this directive implies conformity to the following European standards:

- EN55103-1 : Electromagnetic Interference(Emission)
- EN55103-2 : Electromagnetic Susceptibility(Immunity)

This product is intended for use in the following Electromagnetic Environments:

E1 (residential), E2 (commercial and light industrial), E3 (urban outdoors), E4 (controlled EMC environment, ex. TV studio).

#### **For the customers in Europe**

The manufacturer of this product is Sony Corporation, 1-7-1 Konan, Minato-ku, Tokyo, Japan.

The Authorized Representative for EMC and product safety is Sony Deutschland GmbH, Hedelfinger Strasse 61, 70327 Stuttgart, Germany. For any service or guarantee matters please refer to the addresses given in separate service or guarantee documents.

**For kundene i Norge**

Dette utstyret kan kobles til et IT-strømfordelingssystem.

Apparatet må tilkoples jordet stikkontakt

**För kunderna i Sverige**

Apparaten skall anslutas till jordat uttag

**Suomessa asuville asiakkaille**

Laite on liitettävä suojamaadoituskoskettimilla varustettuun pistorasiaan

**For the customers in the USA (LMD-2341W/  
LMD-1541W)**

Lamp in this product contains mercury. Disposal of these materials may be regulated due to environmental considerations. For disposal or recycling information, please contact your local authorities or the Telecommunications Industry Association ([www.eiae.org](http://www.eiae.org)).

---

# Table of Contents

<b>Precaution</b> .....	<b>6</b>
On Safety .....	6
On Installation .....	6
Handling the LCD Screen .....	6
On Burn-in .....	6
On a Long Period of Use .....	6
On Cleaning .....	7
On Moisture Condensation .....	7
On Repacking .....	7
On Mounting on a Rack .....	7
On Fan Error .....	7
<b>Features</b> .....	<b>8</b>
<b>Location and Function of Parts and</b>	
<b>Controls</b> .....	<b>10</b>
Front Panel .....	10
Input Signals and Adjustable/Setting Items .....	12
Rear Panel .....	13
<b>Installing the Control Panel Cover</b>	
(LMD-2341W only) .....	<b>14</b>
<b>Installing the Stand (LMD-2041W only)</b> .....	<b>15</b>
<b>Installing on a Rack (For LMD-2041W with the</b>	
<b>Supplied Mounting Bracket)</b> .....	<b>15</b>
<b>Installing on a Rack</b>	
(For LMD-1541W with MB-534) .....	<b>16</b>
<b>Adjusting the Height of the Stand</b>	
(with SU-561) .....	<b>16</b>
<b>Connecting the AC Power Cord</b> .....	<b>18</b>
<b>Selecting the Default Settings</b> .....	<b>18</b>
<b>Selecting the Menu Language</b> .....	<b>20</b>
<b>Using the Menu</b> .....	<b>21</b>
<b>Adjustment Using the Menus</b> .....	<b>22</b>
Items .....	22
Adjusting and Changing the Settings .....	23
STATUS menu.....	23
COLOR TEMP/SPACE menu .....	24
USER CONTROL menu.....	24
USER CONFIG menu.....	25
REMOTE menu .....	32
KEY INHIBIT menu.....	34
<b>Troubleshooting</b> .....	<b>35</b>
<b>Specifications</b> .....	<b>35</b>
<b>Dimensions</b> .....	<b>38</b>

---

# Precaution

---

## On Safety

- Operate the unit only with a power source as specified in the “Specifications” section.
- A nameplate indicating operating voltage, etc., is located on the rear panel.
- Should any solid object or liquid fall into the cabinet, unplug the unit and have it checked by qualified personnel before operating it any further.
- Do not drop or place heavy objects on the power cord. If the power cord is damaged, turn off the power immediately. It is dangerous to use the unit with a damaged power cord.
- Unplug the unit from the wall outlet if it is not to be used for several days or more.
- Disconnect the power cord from the AC outlet by grasping the plug, not by pulling the cord.
- The socket-outlet shall be installed near the equipment and shall be easily accessible.

---

## On Installation

- Allow adequate air circulation to prevent internal heat build-up.  
Do not place the unit on surfaces (rugs, blankets, etc.) or near materials (curtains, draperies) that may block the ventilation holes.
- Do not install the unit in a location near heat sources such as radiators or air ducts, or in a place subject to direct sunlight, excessive dust, mechanical vibration or shock.

---

## Handling the LCD Screen

- The LCD panel fitted to this unit is manufactured with high precision technology, giving a functioning pixel ratio of at least 99.99%. Thus a very small proportion of pixels may be “stuck”, either always off (black), always on (red, green, or blue), or flashing. In addition, over a long period of use, because of the physical characteristics of the liquid crystal display, such “stuck” pixels may appear spontaneously. These problems are not a malfunction.
- Do not leave the LCD screen facing the sun as it can damage the LCD screen. Take care when you place the unit by a window.
- Do not push or scratch the LCD monitor’s screen. Do not place a heavy object on the LCD monitor’s screen. This may cause the screen to lose uniformity.

- If the unit is used in a cold place, horizontal lines or a residual image may appear on the screen. This is not a malfunction. When the monitor becomes warm, the screen returns to normal.
- The screen and the cabinet become warm during operation. This is not a malfunction.

---

## On Burn-in

For LCD panel, permanent burn-in may occur if still images are displayed in the same position on the screen continuously, or repeatedly over extended periods.

Images that may cause burn-in

- Masked images with aspect ratios other than 16:9 (LMD-2341W/LMD-2041W)
- Masked images with aspect ratios other than 15:9 (LMD-1541W)
- Color bars or images that remain static for a long time
- Character or message displays that indicate settings or the operating state

### To reduce the risk of burn-in

- Turn off the character displays  
Press the MENU button to turn off the character displays. To turn off the character displays of the connected equipment, operate the connected equipment accordingly. For details, refer to the operation manual of the connected equipment.
- Turn off the power when not in use  
Turn off the power if the viewfinder is not to be used for a prolonged period of time.

---

## On a Long Period of Use

Due to the characteristics of LCD panel, displaying static images for extended periods, or using the unit repeatedly in a high temperature/high humidity environments may cause image smearing, burn-in, areas of which brightness is permanently changed, lines, or a decrease in overall brightness.

In particular, continued display of an image smaller than the monitor screen, such as in a different aspect ratio, may shorten the life of the unit.

Avoid displaying a still image for an extended period, or using the unit repeatedly in a high temperature/high humidity environment such an airtight room, or around the outlet of an air conditioner.

To prevent any of the above issues, we recommend reducing brightness slightly, and to turn off the power whenever the unit is not in use.

---

## On Cleaning

### Before cleaning

Be sure to disconnect the AC power cord from the AC outlet.

### On cleaning the monitor screen

The monitor screen surface is especially treated to reduce reflection of light.

As incorrect maintenance may impair the performance of the monitor, take care with respect to the following:

- Wipe the screen gently with a soft cloth such as a cleaning cloth or glass cleaning cloth.
- Stubborn stains may be removed with a soft cloth such as a cleaning cloth or glass cleaning cloth lightly dampened with water.
- Never use solvent such as alcohol, benzene or thinner, or acid, alkaline or abrasive detergent, or chemical cleaning cloth, as they will damage the screen surface.

### On cleaning the cabinet

- Clean the cabinet gently with a soft dry cloth. Stubborn stains may be removed with a cloth lightly dampened with mild detergent solution, followed by wiping with a soft dry cloth.
- Use of alcohol, benzene, thinner or insecticide may damage the finish of the cabinet or remove the indications on the cabinet. Do not use these chemicals.
- If you rub on the cabinet with a stained cloth, the cabinet may be scratched.
- If the cabinet is in contact with a rubber or vinyl resin product for a long period of time, the finish of the cabinet may deteriorate or the coating may come off.

---

## On Moisture Condensation

If the unit is brought directly from a cold place to a warm place, or the unit is warm and the ambient temperature cools suddenly (by air-conditioning, for example), moisture may condense on the surface or inside of the unit, or create a mist residue inside the protection plate if it is installed to the unit.

This is called moisture condensation, and is not a malfunction of the product itself, although it may cause damage to the unit.

Leave the unit in a condensation free area.

If moisture condensation has occurred, turn off the unit and do not use it until moisture condensation has evaporated.

---

## On Repacking

Do not throw away the carton and packing materials. They make an ideal container which to transport the unit.

---

## On Mounting on a Rack

Leave 1U space empty above and below the monitor to ensure adequate air circulation or install a fan to maintain the monitor's performance.

If you have any questions about this unit, contact your authorized Sony dealer.

---

## On Fan Error

The fan for cooling the unit is built in. When the fan stops and the  (standby) switch indicator on the front panel blinks in green and amber for fan error indication, turn off the power and contact an authorized Sony dealer.

### About this manual

The instructions in this manual are for the following models:

- LMD-2341W
- LMD-2041W
- LMD-1541W

The illustration of LMD-2341W is used for the explanations. Any differences in specifications are clearly indicated in the text.

---

# Features

The LMD-2341W (23.0-type), LMD-2041W (20.0-type) or LMD-1541W (15.3-type) is a multiple format LCD monitor for broadcast or business use featuring a precise image and high performance. It supports digital/analog main broadcast signals and HDMI<sup>1)</sup>, and comes equipped with functions for monitor wall viewing in a studio or a broadcasting van.

<sup>1)</sup> HDMI, the HDMI logo and High-Definition Multimedia Interface are trademarks or registered trademarks of HDMI Licensing LLC.

## High brightness LCD panel

Because of its precise image, wide viewing angle technology and high-speed response, a lifelike color image can be reproduced.

## Concise and lightweight monitor housing

Designed to be lightweight, durable and compact with a narrow bezel, the aluminum housing is suitable for mounting on a wall or rack. It lightens the load on your broadcasting van and saves space.

## External remote function

The input signal is selected (or various items adjusted) by the serial (Ethernet) remote function. Up to 32 monitors and control units (max. 4) can be connected by the Ethernet (10BASE-T/100BASE-TX) connection and controlled remotely on the network. You can control individual monitors or monitor groups simply by entering the monitor ID or group ID number. You can also execute the same operation on all connected monitors, or put all connected monitors into the same setup and adjustment state.

*For more information, see SERIAL REMOTE of the REMOTE menu on page 34.*

*Refer to the Operation Manual of the BKM-15R/16R Monitor Control Unit (optional).*

## IMD (in-monitor display)

With the external remote function, image source names and tally information are displayed on the screen.

*For more information, see IMD (in-monitor display) SETTING on page 27.*

## Input signal waveform and audio level display

The waveform of the input signal or the audio level (embedded audio only) is displayed as the sub display.

*For more information, see WFM/ALM (waveform monitor and audio level meter) DISPLAY SETTING on page 28.*

## Timecode display

Timecode superimposed on SDI signals is displayed on the screen.

*For more information, see T/C (time code) DISPLAY SETTING on page 27.*

## I/P mode select

The desired I/P mode for interlace signal can be selected for your purpose.

*For more information, see SYSTEM SETTING on page 25.*

## Color space function

You can select any of three color space settings (SMPTE-C/EBU/ITU-R BT.709).

## Selecting marker/scan display

Various items for broadcast use can be displayed. The center marker, safe area marker, aspect marker or display size (scan), etc., are displayed by selecting according to use.

*For more information, see MARKER SETTING on page 26, and see SCAN of FUNCTION BUTTON SETTING on page 29.*

## Scan setting /native display

When video signals are input, you can set the display size to 0% scan (normal), 5% over scan (over) or zoom mode (full screen).

A native display function that maps the pixel of the signal to the panel in one-to-one mode is also equipped. Scaling to correct the screen aspect ratio is done to the horizontal direction of SD signals with non-square pixels (number of horizontal pixels of the signal system is 720 or 1440) or 640 × 480 SD signal of HDMI video.

## Key inhibit function

You can inhibit a key function to prevent missing an operation.

## Illuminated control panel

The characters that represent the names of the buttons on the control panel can be illuminated, so it is visible in the dark. The brightness of the LED has two levels, and varies according to the ambient light.

## Rack mount

LMD-2341W, LMD-2041W and LMD-1541W support the VESA (100 × 100) standard. The LMD-2041W and LMD-1541W can also be mounted on an EIA-standard 19-inch rack (using the supplied mounting bracket for LMD-2041W, or an optional mounting bracket MB-534 for LMD-1541W).

*For more information, see “Installing on a Rack (For LMD-1541W with MB-534)” on page 16.*



Consult with Sony qualified personnel for wall mount installation.

**Monitor stand with tilt function**

LMD-2341W, LMD-2041W and LMD-1541W can be mounted on the optional SU-561 Monitor Stand with tilt and height adjustment. You can select the height of the monitor by adjusting the stand.

*For more information, see “Adjusting the Height of the Stand (with SU-561)” on page 16.*

LMD-1541W is also supported by the optional SU-562 Monitor Stand that is designed to be lightweight and compact with tilt adjustment.

# Location and Function of Parts and Controls

## Front Panel

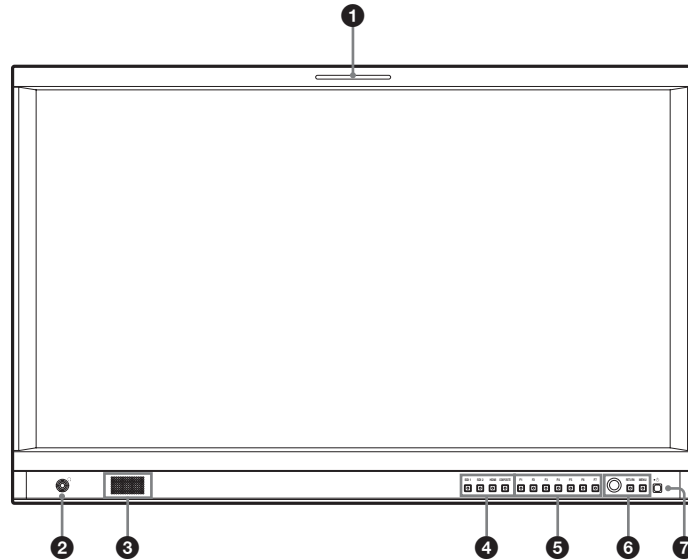

### ❶ Tally lamp

You can check the status of the monitor by the color of the tally lamp.

The tally lamp lights in red, green or amber according to the setting of PARALLEL REMOTE in the REMOTE menu.

### ❷ (headphones) jack

The audio signal which is selected by the input select button is output in stereo sound.

### ❸ Speaker

The audio signal which is selected by the input select button is output in monaural sound (L + R).

When SDI signals are input, the audio which is selected in AUDIO SETTING of the USER CONFIG menu is output (see page 32).

The audio signals from the speaker are output from the AUDIO OUT connector on the rear (see page 13).

Audio signals will not be output when headphones are connected to the  jack.

### ❹ Input select buttons

Press to monitor the signal input to each connector.

**SDI 1 button:** to monitor the signal through the SDI 1 input connector

**SDI 2 button:** to monitor the signal through the SDI 2 input connector

**HDMI button:** to monitor the signal through the HDMI connector

**COMPOSITE button:** to monitor the signal through the COMPOSITE IN connector

### ❺ Function buttons

You can turn the assigned function on or off. The factory setting is as follows;

**F1 button:** BRIGHTNESS

**F2 button:** CONTRAST

**F3 button:** CHROMA

**F4 button:** SCAN

**F5 button:** H/V DELAY

**F6 button:** VOLUME

**F7 button:** I/P MODE

You can assign various functions in FUNCTION BUTTON SETTING of the USER CONFIG menu.

Press the button BRIGHTNESS, CONTRAST, CHROMA, or VOLUME function assigned to display the adjustment screen. Press the same button again, and the adjustment screen disappears, but you can adjust the value without the setting value display.

*For details of the function assigned to the function button, see page 29.*

### ❻ Menu operation buttons

Displays or sets the on-screen menu.

#### Menu selection control

When the menu is displayed, turn the control to select a menu item or setting value, and then press the control to confirm the setting.

**To light up the characters that represent the names of the buttons**

When the menu is not displayed, press the menu selection control. Press it again to turn off the lights.

**To display the signal format**

When the menu is not displayed, press the menu selection control for more than two seconds.

**RETURN button**

When the menu is displayed, press the button to reset the value of an item to the previous value (except some items).

**To display the names of functions assigned to the function buttons**

When the menu is not displayed, press RETURN. The names of the function selected in FUNCTION BUTTON SETTING of the USER CONFIG menu appear in the lower right of the screen.

**MENU button**

Press to display the on-screen menu.

Press again to clear the menu.

**⑦  (standby) switch and indicator**

Press to turn on the power when this unit is in standby mode. The indicator lights in green. Press the switch again to set the monitor in standby mode. The indicator goes out. When fan error occurs, the indicator blinks in green and amber alternately. In power saving mode, it lights in amber.

## Input Signals and Adjustable/Setting Items

Item	Input signal							
	Composite		SDI			HDMI/DVI*5		
	Color	B & W	SD	HD	3G	SD	HD	PC
CONTRAST*1	○	○	○	○	○	○	○	○
BRIGHT*1	○	○	○	○	○	○	○	○
CHROMA*1	○	×	○	○	○	○	○	○
PHASE*1	○ (NTSC)	×	×	×	×	×	×	○
APERTURE	○	○	○	○	○	○	○	○
COLOR TEMP	○	○	○	○	○	○	○	○
COLOR SPACE	○	○	○	○	○	○	○	○
AUTO CHROMA/PHASE	○	×	×	×	×	×	×	×
ACC	○	×	×	×	×	×	×	×
CTI	○	×	×	×	×	×	×	×
V SHARPNESS	○	○	○	×	×	○	×	×
NTSC SETUP	○ (NTSC)	○ (480/60I)	×	×	×	×	×	×
SCAN	○	○	○	○	○	○	○	×
ASPECT	○	○	○	×	×	○	×	×
MARKER	○	○	○	○	○	○	○	×
BLUE ONLY	○	×	○	○	○	○	○	×
MONO	○	×	○	○	○	○	○	×
H/V DELAY	○	○	○	○	○	×	×	×
SHIFT	○	○	○	○	○	○	○	×
POWER SAVING	○	○	○	○	○	○	○	○
I/P MODE*2	○	○	○	○	○	○	○	×
WFM/ALM*3	○	○	○	○	○	○	○	○
CAMERA FOCUS	○	○	○	○	○	○	○	×
RGB RANGE*4	×	×	×	×	×	○	○	○
T/C	×	×	○	○	○	×	×	×
IMD	○	○	○	○	○	○	○	○
DVI*5	×	×	×	×	×	○	○	○
SD PIXEL MAPPING*6	○	○	×	×	×	×	×	×

○ : Adjustable/can be set

× : Not adjustable/cannot be set

\*1 Adjustment of SUB CONTROL is the same.

\*2 Only the interlace signal is input.

\*3 The audio levels of WFM or ALM are displayed when SDI signal is input. Select the displayed audio level channels in SDI AUDIO SETTING (see WFM/ALM SELECT on page 28).

\*4 Adjustable when RGB format of HDMI signals are input.

\*5 When DVI signal is input to the HDMI IN connector using a DVI conversion cable, this can be adjusted.

\*6 Only LMD-2041W allows for setting.

# Rear Panel

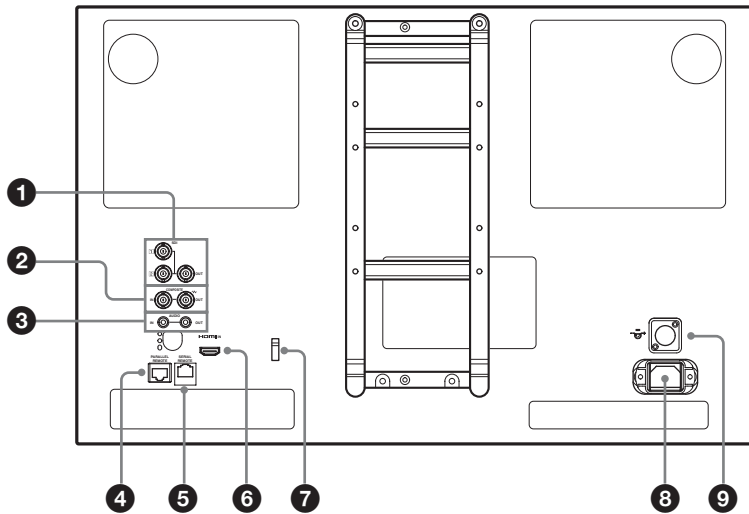

## 1 SDI (3G/HD/SD) input and output connectors (BNC)

### 1 (input) connector, 2 (input) connector

Input connector for serial digital component signals. SDI 1 and SDI 2 inputs are available.

### OUT connector

Output connector for serial digital component signals.

#### Notes

- The signal from the OUT connector does not satisfy the ON-LINE signal specifications.
- Output is only activated when the power is on. No output in standby mode.

## 2 COMPOSITE input and output connectors (BNC)

### IN connector

Input connector for composite video signals.

### OUT connector

Loop-through output connector.

#### Note

When inputting a video signal with the jitters, etc. the picture may be disturbed. We recommend using the TBC (time base corrector).

## 3 AUDIO input and output connectors (stereo mini jack)

### IN connector

Connect to the audio outputs of external equipment such as a VCR.

### OUT connector

Outputs the audio signal which is selected by the input select button on the front panel.

When SDI signal is selected, either the audio signal of the channel which is selected in AUDIO SETTING of

the USER CONFIG menu or the audio signal from the AUDIO IN connector is output.

## 4 PARALLEL REMOTE connector (modular connector, 8-pin)

Forms a parallel switch and controls the monitor externally.

*For details on the pin assignment and factory setting function assigned to each pin, see page 37.*

#### CAUTION

For safety, do not connect the connector for peripheral device wiring that might have excessive voltage to this port. Follow the instructions for this port.

## 5 SERIAL REMOTE connector (RJ-45)

Connect to the network or Sony BKM-15R/16R Monitor Control Unit by using a 10BASE-T/100BASE-TX LAN cable (shielded type, optional).

*For details, refer to the Interface Manual for Programmers (saved in the supplied CD-ROM, Japanese and English only).*

#### CAUTION

- For safety, do not connect the connector for peripheral device wiring that might have excessive voltage to this port. Follow the instructions for this port.
- When you connect the LAN cable of the unit to peripheral device, use a shielded-type cable to prevent malfunction due to radiation noise.
- The connection speed may be affected by the network system. This unit does not guarantee the communication speed or quality of 10BASE-T/100BASE-TX.

## ⑥ HDMI input connector

Input connector for HDMI signals.

HDMI (High-Definition Multimedia Interface) is an interface that supports both video and audio on a single digital connection, allowing you to enjoy high quality digital picture and sound. The HDMI specification supports HDCP (High-bandwidth Digital Content Protection), a copy protection technology that incorporates coding technology for digital video signals.

### Note

Use HDMI compliant cable (optional) with HDMI logo.

## ⑦ HDMI cable holder

Secures the HDMI cable (Ø7 mm or less).

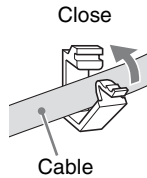

## ⑧ AC IN Socket

Connects the supplied AC power cord.

## ⑨ DC IN connector

Plug the DC power supply to this connector to provide power to the monitor. LMD-2341W runs on DC 24V. LMD-2041W and LMD-1541W run on DC 12V.

### CAUTION

Be sure to connect to a power supply of the specified voltage value.

# Installing the Control Panel Cover (LMD-2341W only)

The front control panel of LMD-2341W can be covered using the supplied accessories. Install the supplied cover on the bottom of the monitor with the provided screws.

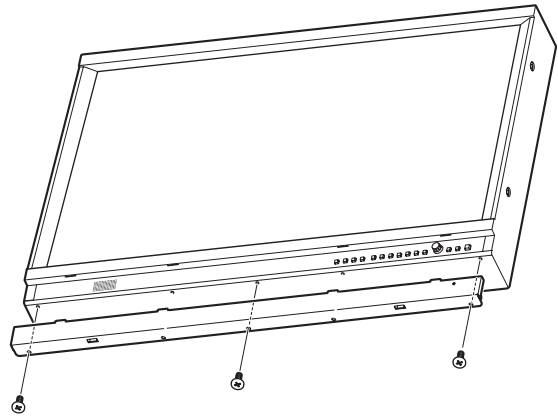

## Installing the Stand (LMD-2041W only)

The supplied stand can be installed on LMD-2041W. Install the supplied stand on the bottom of the monitor with the provided screws.

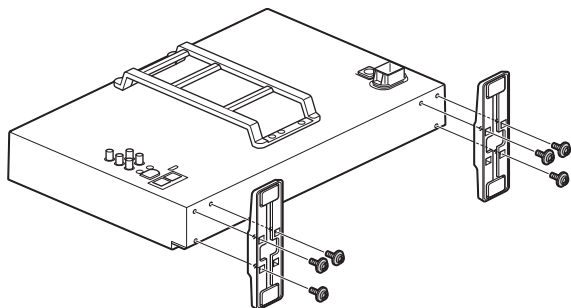

## Installing on a Rack (For LMD-2041W with the Supplied Mounting Bracket)

You can attach a monitor to the rack by using the supplied mounting bracket.

- 1 Attach the mounting bracket to the monitor.

Install the mounting bracket to the top and bottom of the monitor with the provided screws.

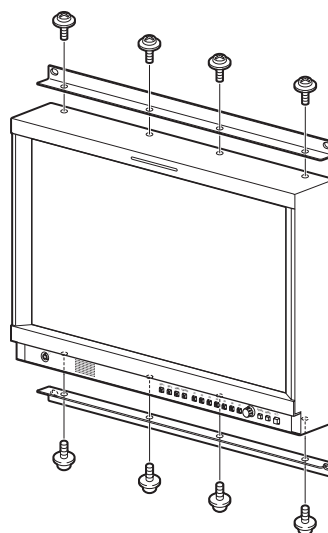

- 2 Attach the unit to the rack with four screws.

### Note

The screws are not supplied. Prepare screws according to the rack.

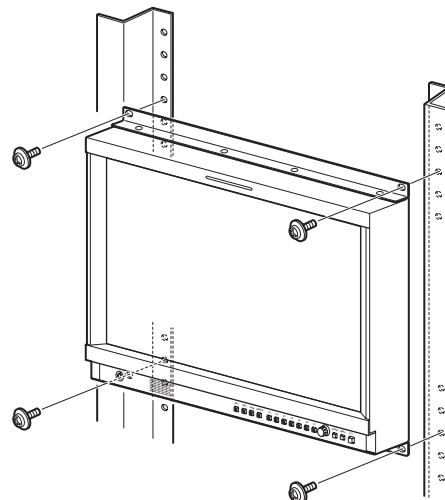

# Installing on a Rack (For LMD-1541W with MB-534)

You can attach a monitor to the rack by using the optional MB-534 Mounting Bracket.

- 1 Attach the mounting bracket to the monitor.

*For details on attaching the mounting bracket, refer to the Mounting Instructions of the MB-534.*

- 2 Attach the unit to the rack with four screws.

**Note**

The screws are not supplied. Prepare screws according to the rack.

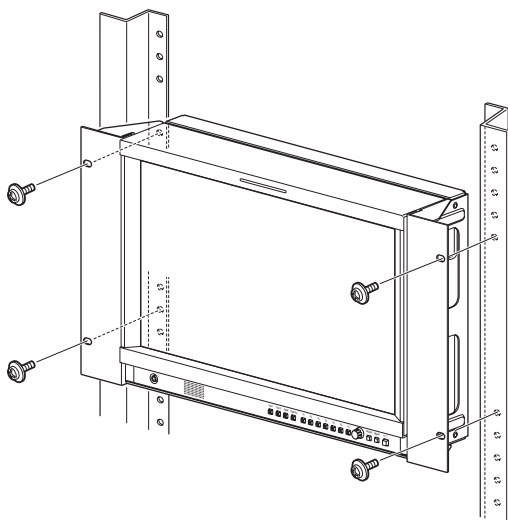

# Adjusting the Height of the Stand (with SU-561)

LMD-2341W, LMD-2041W and LMD-1541W can be mounted on the optional SU-561 Monitor Stand. You can adjust the height of the monitor on four levels by changing the position of the stand attachment bracket and the arm attachment position.

A and B in the following list indicate the screw holes shown in the illustrations of steps 2 and 4.

**Height of the monitor**

	Unit: mm (inches)			
Position of the stand attachment bracket	A	A	B	B
Arm attachment position	B	A	B	A
LMD-2341W	406.1 (16)	432.4 (17 1/8)	444.1 (17 1/2)	467.4 (18 1/2)
LMD-2041W	368.4 (14 5/8)	394.7 (15 5/8)	425.7 (16 7/8)	452.0 (17 7/8)
LMD-1541W	362.6 (14 3/8)	388.9 (15 3/8)	397.6 (15 3/4)	423.9 (16 3/4)

The following explains how to adjust the height of the stand. For details on mounting the monitor on SU-561, refer to the Mounting Instructions of SU-561.

- 1 Remove the stand and stand attachment bracket if they have already been attached (see page 17).
- 2 Attach the stand attachment bracket to the A or B screw holes.

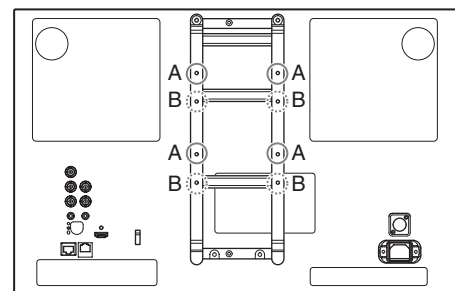

A: Screw holes for low position  
B: Screw holes for high position

- 3 Attach the stand attachment bracket with four screws.

**When removing the stand and stand attachment bracket in step 1**



Use the screws removed in step 5 of “To remove the stand and stand attachment bracket” (see page 17).

**When following step 2**

Use the screws supplied with SU-561.

**4** Attach the arm.

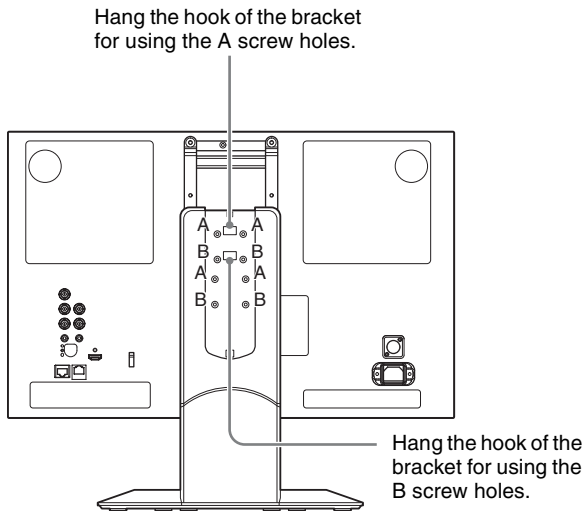

**5** Secure the arm with four screws.

**When removing the stand and stand attachment bracket in step 1**

Use the screws removed in step 3 of “To remove the stand and stand attachment bracket” (see page 17).

**When following step 2**

Use the screws supplied with SU-561.

**6** Attach the arm cover.

**To remove the stand and stand attachment bracket**

- 1** Put the monitor on a soft cloth with the surface of the LCD monitor downward.
- 2** Slide and remove the arm cover of the stand.
- 3** Remove the four screws.
- 4** Remove the arm.

**5** Remove the four screws to remove the stand attachment bracket.

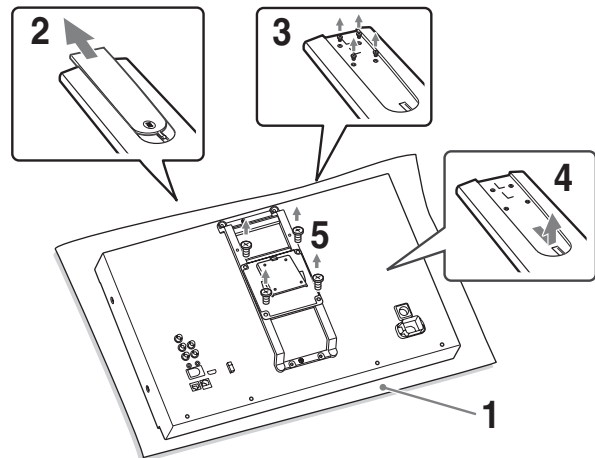

# Connecting the AC Power Cord

- 1 Plug the AC power cord into the AC IN socket on the rear panel. Then, attach the AC plug holder (supplied) to the AC power cord.

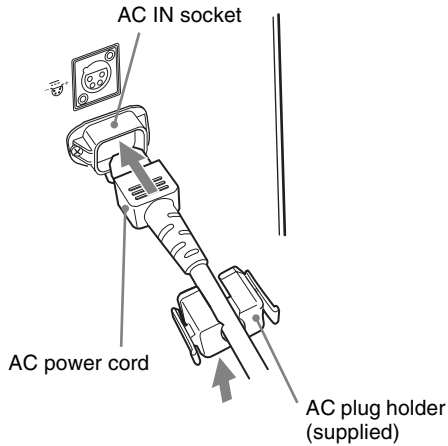

- 2 Slide the AC plug holder over the cord until it locks.

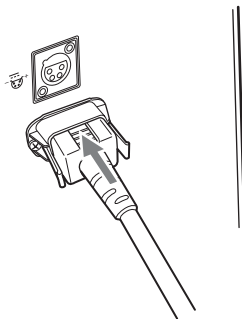

## To disconnect the AC power cord

Pull out the AC plug holder while pressing the lock levers.

# Selecting the Default Settings

When you turn on the unit for the first time after purchasing it, select the area where you intend to use this unit from among the options.

## The default setting values for each area

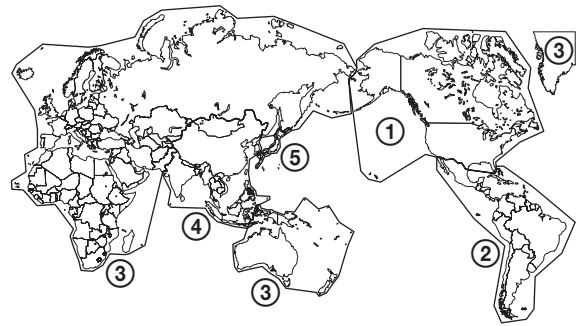

		COLOR TEMP	NTSC SETUP	COLOR SPACE
① NORTH AMERICA		D65	7.5	SMPTE-C
② LATIN AMERICA	ARGENTINA	D65	0	EBU
	PAL&PAL-N AREA PARAGUAY	D65	0	EBU
	URUGUAY	D65	0	EBU
	NTSC&PAL-M AREA OTHER AREA	D65	7.5	SMPTE-C
③ AFRICA AUSTRALASIA EUROPE MIDDLE-EAST		D65	0	EBU
④ ASIA EXCEPT JAPAN	NTSC AREA	D65	7.5	SMPTE-C
	PAL AREA	D65	0	EBU
⑤ JAPAN		D93	0	EBU

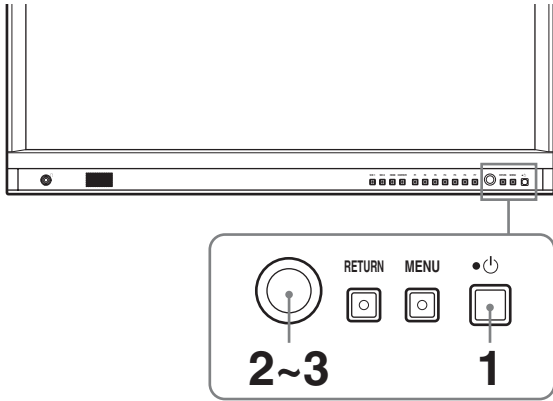

**1** Press the (standby) switch.

The unit is turned on and the SELECT SETTING screen appears.

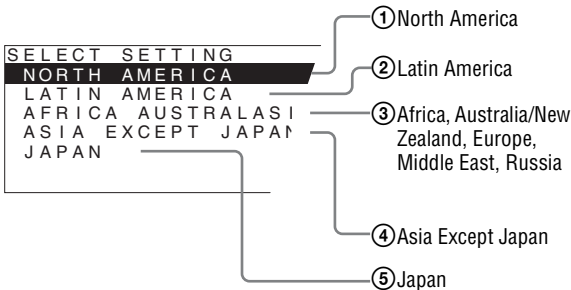

**2** Turn the menu selection control to select the area where you intend to use the unit and press the menu selection control.

**If you select either ①, ③ or ⑤**  
The confirmation screen is displayed. Confirm the selected area. When the setting is wrong, press the RETURN button to return to the previous screen.

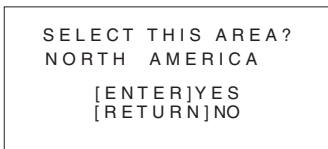

**If you select either ② or ④**  
One of the following screens appears. Turn the menu selection control to narrow the area further and then press the menu selection control. The confirmation screen is displayed. Confirm the selected area.  
If the setting is wrong, press the RETURN button to return to the previous screen.

**② If LATIN AMERICA is selected:**

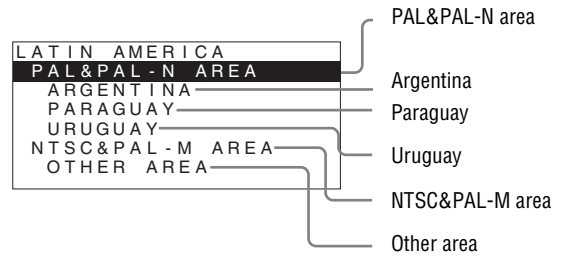

**④ If ASIA EXCEPT JAPAN is selected:**  
Customers who will use this unit in the shaded areas shown in the map below should select NTSC AREA.  
Other customers should select PAL AREA.

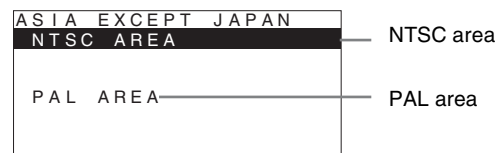

**3** Press the menu selection control.

The SELECT SETTING screen disappears and the menu item settings suitable for the selected area are applied.

**Note**

When you have selected the wrong area, set the following items using the menu.

- COLOR TEMP (on page 24)
- NTSC SETUP (on page 25)
- COLOR SPACE (on page 24)

See “The default setting values for each area” (page 18) on the setting value.

# Selecting the Menu Language

You can select one of seven languages (English, French, German, Spanish, Italian, Japanese, Chinese) for displaying the menu and other on-screen displays. “ENGLISH (English)” is selected in the default setting. The current settings are displayed in place of the ■ marks on the illustrations of the menu screen.

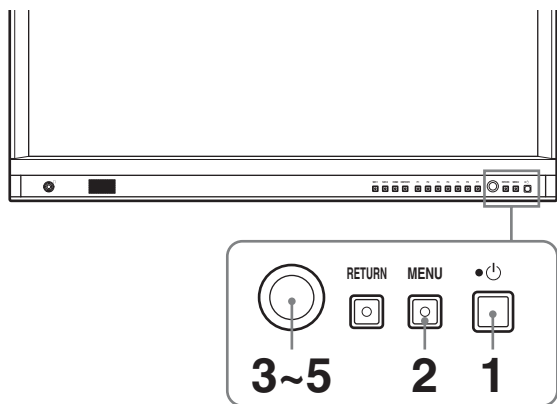

- 1 Turn on the unit.
- 2 Press the MENU button.

The menu appears.  
The menu presently selected is shown in yellow.

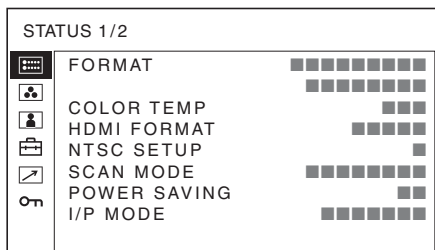

- 3 Turn the menu selection control to select SYSTEM SETTING of the USER CONFIG (user configuration) menu, then press the menu selection control.

The setting items (icons) in the selected menu are displayed in yellow.

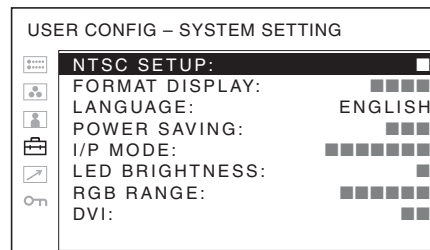

- 4 Turn the menu selection control to select “LANGUAGE”, then press the menu selection control.

The selected item is displayed in yellow.

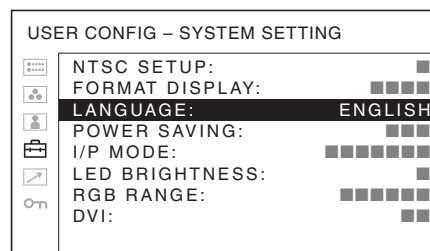

- 5 Turn the menu selection control to select a language, then press the menu selection control.

The menu changes to the selected language.

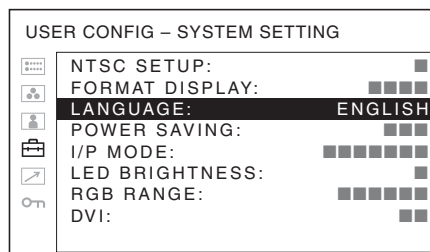

## To clear the menu

Press the MENU button.  
The menu disappears automatically if a button is not pressed for one minute.

# Using the Menu

The unit is equipped with an on-screen menu for making various adjustments and settings such as picture control, input setting, set setting change, etc. You can also change the menu language displayed in the on-screen menu.

To change the menu language, see “Selecting the Menu Language” on page 20.

The current settings are displayed in place of the ■ marks on the illustrations of the menu screen.

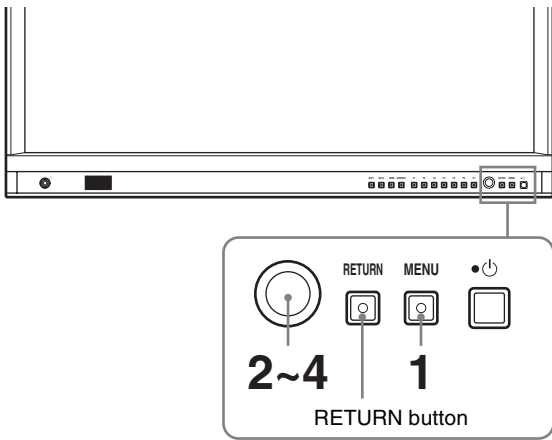

**1** Press the MENU button.

The menu appears.  
The menu presently selected is shown in yellow.

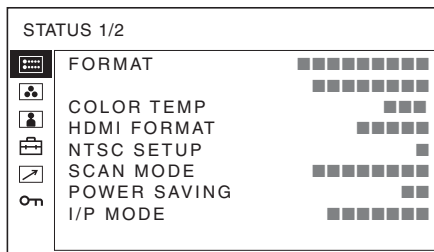

**2** Turn the menu selection control to select a menu, then press the menu selection control.

The menu icon presently selected is shown in yellow and setting items are displayed.

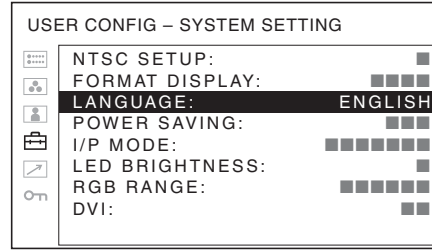

**3** Select an item.

Turn the menu selection control to select the item, then press the menu selection control. The item to be changed is displayed in yellow. If the menu consists of multiple pages, turn the menu selection control to go to the desired menu page.

**4** Make the setting or adjustment on an item.

**When changing the adjustment level:**

To increase the number, turn the menu selection control right.

To decrease the number, turn the menu selection control left.

Press the menu selection control to confirm the number, then restore the original screen.

**When changing the setting:**

Turn the menu selection control to change the setting, then press the menu selection control to confirm the setting.

**When returning the adjustment or setting to the previous value:**

Press the RETURN button before pressing the menu selection control.

**Notes**

- An item displayed in black cannot be accessed. You can access the item if it is displayed in white.
- If the key inhibit has been turned on, all items are displayed in black. To change any of the items, turn the key inhibit to OFF first.

For details on the key inhibit, see page 34.

**To return the display to the previous screen**

Press the RETURN button.

**To clear the menu**

Press the MENU button.

The menu disappears automatically if a button is not pressed for one minute.

### About the memory of the settings

The settings are automatically stored in the monitor memory.

---

# Adjustment Using the Menus

---

## Items

The screen menu of this monitor consists of the following items.

### **STATUS (the items indicate the current settings.)**

#### **For the video input**

FORMAT  
COLOR TEMP  
HDMI FORMAT  
NTSC SETUP  
SCAN MODE  
POWER SAVING  
I/P MODE  
Model name and serial number

#### **For the DVI input signal from PC**

FORMAT  
fH  
fV  
COLOR TEMP  
HDMI FORMAT  
POWER SAVING  
Model name and serial number

### **COLOR TEMP/SPACE**

COLOR TEMP  
MANUAL ADJUSTMENT  
COLOR SPACE

### **USER CONTROL**

SUB CONTROL  
AUTO CHROMA/PHASE  
PICTURE CONTROL  
INPUT SETTING

### **USER CONFIG**

SYSTEM SETTING  
NTSC SETUP  
FORMAT DISPLAY  
LANGUAGE  
POWER SAVING  
I/P MODE  
LED BRIGHTNESS  
RGB RANGE  
DVI

SD PIXEL MAPPING (LMD-2041W only)

**MARKER SETTING**

MARKER ENABLE  
MARKER SELECT  
CENTER MARKER  
SAFETY AREA  
MARKER LEVEL  
MARKER MAT

**T/C DISPLAY SETTING**

T/C

FORMAT

POSITION

TRANSPARENCY

**IMD SETTING**

IMD

POSITION

TRANSPARENCY

TEXT COLOR

TEXT BRIGHTNESS

TALLY 1

TALLY 2

**WFM/ALM (waveform monitor and audio level meter) DISPLAY SETTING**

WFM/ALM

WFM/ALM SELECT

POSITION

TRANSPARENCY

**FUNCTION BUTTON SETTING**

F1 BUTTON

F2 BUTTON

F3 BUTTON

F4 BUTTON

F5 BUTTON

F6 BUTTON

F7 BUTTON

**AUDIO SETTING**

SDI AUDIO SETTING

 **REMOTE**

PARALLEL REMOTE

SERIAL REMOTE

 **KEY INHIBIT**

KEY INHIBIT

---

## Adjusting and Changing the Settings

 **STATUS menu**

The STATUS menu is used to display the current status of the unit. The following items are displayed:

### For the video input

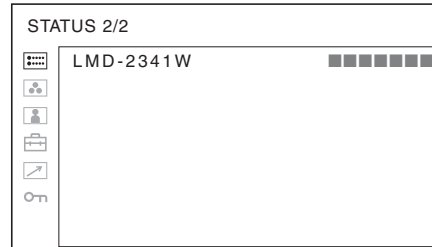
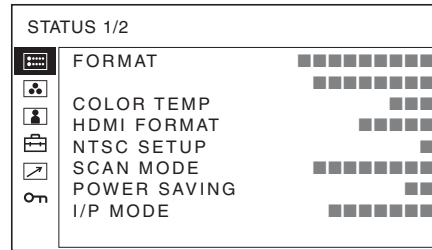

- Signal format
- Color temperature
- HDMI format
- NTSC setup
- Scan mode
- Power saving
- I/P mode
- Model name and serial number

### For the DVI input signal from PC

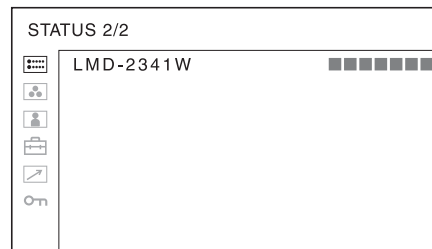
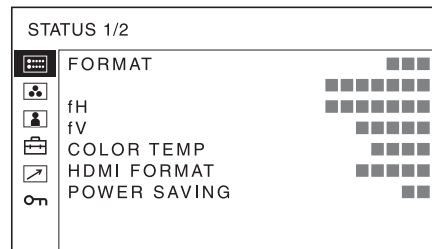

- Signal format
- fH
- fV
- Color temperature
- HDMI format
- Power saving
- Model name and serial number

## COLOR TEMP/SPACE menu

The COLOR TEMP/SPACE menu is used for adjusting the picture white balance or color space.

You need to use the measurement instrument to adjust the white balance.

Recommended: Konica Minolta color analyzer CA-210

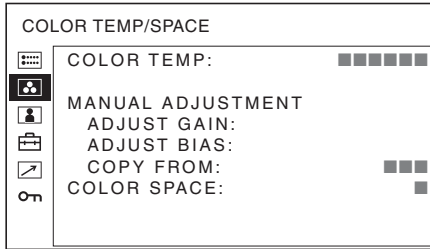

Submenu	Setting
COLOR TEMP	Selects the color temperature from among D65, D93 and USER setting.
MANUAL ADJUSTMENT	<p>If you set the COLOR TEMP to USER setting, the item displayed is changed from black to white, which means you can adjust the color temperature.</p> <p>The set values are memorized.</p> <ul style="list-style-type: none"> <li>• <b>ADJUST GAIN:</b> Adjusts the color balance (GAIN).</li> <li>• <b>ADJUST BIAS:</b> Adjusts the color balance (BIAS).</li> <li>• <b>COPY FROM:</b> If you select D65 or D93, the white balance data for the selected color temperature will be copied in the USER setting.</li> </ul>
COLOR SPACE	Selects the color space from among ITU-709, EBU, SMPTE-C and OFF. OFF sets the color space to the original color reproduction of the LCD panel.

## USER CONTROL menu

The USER CONTROL menu is used for adjusting the picture.

Items that cannot be adjusted depending on the input signal are displayed in black.

*For details of input signal and adjustable / setting items, see page 12.*

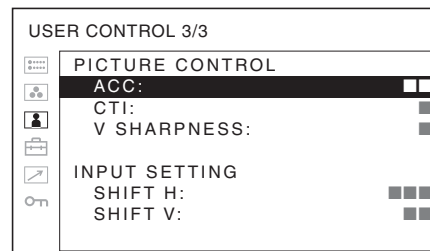
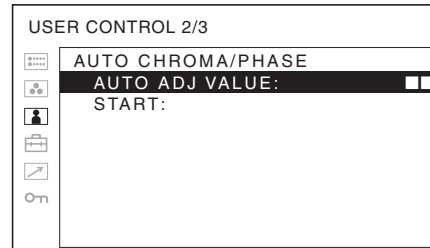
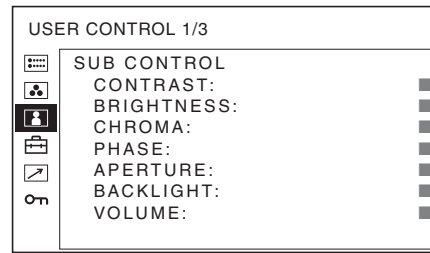

Submenu	Setting
SUB CONTROL	<p>Adjusts finely the adjustment range of the function buttons which CONTRAST, BRIGHTNESS, CHROMA and PHASE are assigned.</p> <ul style="list-style-type: none"> <li>• <b>CONTRAST:</b> Adjusts the picture contrast.</li> <li>• <b>BRIGHTNESS:</b> Adjusts the picture brightness.</li> <li>• <b>CHROMA:</b> Adjusts color intensity. The higher the setting, the greater the intensity. The lower the setting, the lower the intensity.</li> <li>• <b>PHASE:</b> Adjusts color tones. The higher the setting, the more greenish the picture. The lower the setting, the more purplish the picture.</li> <li>• <b>APERTURE:</b> Adjusts the picture sharpness. The higher the setting, the sharper the picture. The lower the setting, the softer the picture. APERTURE does not work when the camera focus function is activated.</li> <li>• <b>BACKLIGHT:</b> Adjusts the backlight. When the setting is changed, the brightness of the backlight is changed.</li> <li>• <b>VOLUME:</b> Adjusts the volume.</li> </ul>



Submenu	Setting
AUTO CHROMA/ PHASE	<p>Adjusts color intensity (CHROMA) and tones (PHASE).</p> <ul style="list-style-type: none"> <li>• <b>AUTO ADJ VALUE:</b> Selects ON or OFF of the auto adjustment. When you set to OFF, this parameter is reset to the factory setting. When you set to ON, the automatically adjusted value is enabled.</li> <li>• <b>START:</b> The auto adjustment starts when you display the color bar signals (Full/SMPTE/EIA) on the screen and press the menu selection control. After adjusting the color intensity, press the MENU button to clear the adjustment screen. After the adjustment is done correctly, the AUTO ADJ VALUE is automatically set to ON.</li> </ul>
PICTURE CONTROL	<p>Adjusts the picture.</p> <ul style="list-style-type: none"> <li>• <b>ACC (Auto Color Control):</b> Sets ACC circuit on or off. To check the fine adjustment, select OFF. Normally select ON.</li> <li>• <b>CTI (Chroma Transient Improvement):</b> When a low color resolution signal is input, a crisp image can be displayed. When the setting is higher, the picture becomes even more crisp.</li> <li>• <b>V SHARPNESS:</b> A crisp image can be displayed. When the setting is higher, the picture becomes even more crisp.</li> </ul>
INPUT SETTING	<ul style="list-style-type: none"> <li>• <b>SHIFT H:</b> Adjusts the position of the picture. As the setting increases, the picture moves to the right, and as the setting decreases, the picture moves to the left.</li> <li>• <b>SHIFT V:</b> Adjusts the position of the picture. As the setting increases, the picture moves up, and as the setting decreases, the picture moves down.</li> </ul>

## USER CONFIG menu

The USER CONFIG menu is used for setting the system, marker, T/C display, IMD, WFM/ALM display, function button, and audio.

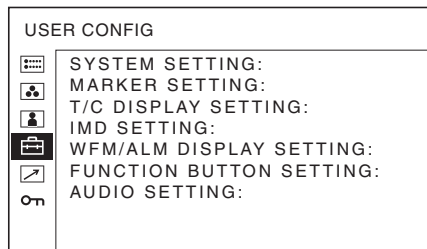

## SYSTEM SETTING

### LMD-2341W/LMD-1541W

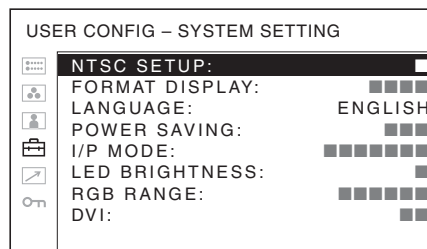

### LMD-2041W

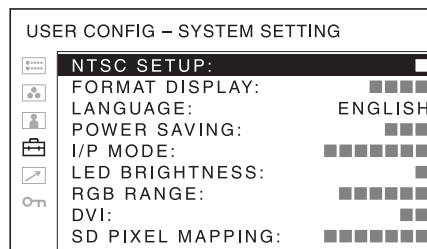

Submenu	Setting
NTSC SETUP	<p>Selects the NTSC setup level from two modes.</p> <p>The 7.5 setup level is used mainly in North America. The 0 setup level is used mainly in Japan.</p>
FORMAT DISPLAY	<p>Selects the display mode of the signal format and scan mode.</p> <ul style="list-style-type: none"> <li>• <b>ON:</b> The format and scan mode are always displayed.</li> <li>• <b>OFF:</b> The display is hidden.</li> <li>• <b>AUTO:</b> The format and scan mode are displayed for about five seconds when the input of the signal starts.</li> </ul>

Submenu	Setting
LANGUAGE	<p>Selects the menu or message language from among seven languages.</p> <ul style="list-style-type: none"> <li>• <b>ENGLISH:</b> English</li> <li>• <b>FRANÇAIS:</b> French</li> <li>• <b>DEUTSCH:</b> German</li> <li>• <b>ESPAÑOL:</b> Spanish</li> <li>• <b>ITALIANO:</b> Italian</li> <li>• 日本語 : Japanese</li> <li>• 中文 : Chinese</li> </ul>
POWER SAVING	<p>Sets the power saving mode on or off. When you set to ON, the monitor goes into power saving mode if no signal is input for about one minute.</p>
I/P MODE (picture delay minimum)	<p>Selects to set the delay by the picture processing to the minimum level when the interlace signal is input.</p> <ul style="list-style-type: none"> <li>• <b>INTER-FIELD*</b>: Mode for giving precedence to the picture quality. Performs interpolation depending on the movement of the images between the fields. It takes longer than the other setting modes to process the picture.</li> <li>• <b>FIELD MERGE:</b> The processing time is shorter. Combines the lines in the odd fields and even fields alternately regardless of the movement of images. Suitable for viewing still images.</li> <li>• <b>LINE DOUBLER:</b> The processing time is shorter. Performs interpolation by repeating each line in the data receiving sequence regardless of the field. As the line flicker is displayed in this mode, it is available for checking the line flicker of the telop work and so on.</li> </ul> <p>* When the WFM/ALM display is enabled, INTER-FIELD cannot be selected.</p>
LED BRIGHTNESS	<p>Selects the brightness of the LED of the buttons.</p> <ul style="list-style-type: none"> <li>• <b>HIGH:</b> The LED becomes brighter.</li> <li>• <b>LOW:</b> The LED becomes darker.</li> </ul>
RGB RANGE	<p>Sets the black level and white level for the RGB format of HDMI input.</p> <ul style="list-style-type: none"> <li>• <b>FULL:</b> 0 (black level) to 255 (white level)</li> <li>• <b>LIMITED:</b> 16 (black level) to 235 (white level)</li> </ul>

Submenu	Setting
DVI	<p>Selects a format for DVI input signal.</p> <ul style="list-style-type: none"> <li>• <b>PC:</b> For RGB signal format</li> <li>• <b>VIDEO:</b> For YPbPr signal format</li> </ul>
SD PIXEL MAPPING (LMD-2041W only)	<p>Selects SD picture size (pixels) according to the input signal format from the COMPOSITE IN connector.</p> <p><b>When picture signals in the size of 720 × 576 (50i) (or 720 × 487 (60i)) are input</b>  Select 720 × 576 (or 720 × 487). This is the default setting.  When 702 × 576 (or 712 × 483) is selected, all sides of the input picture are cut off by several pixels.</p> <p><b>When picture signals in the size of 702 × 576 (50i) (or 712 × 483 (60i)) or equivalent are input</b>  Select 702 × 576 (or 712 × 483).  When 720 × 576 (or 720 × 487) is selected, a black border (of several pixels wide) appears around the input picture.</p>

## MARKER SETTING

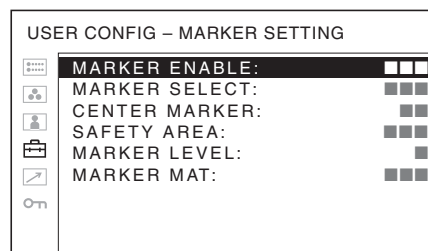

Submenu	Setting
MARKER ENABLE	<p>Selects ON to display the marker and OFF not to display.</p>
	<p><b>Note</b></p> <p>When NATIVE is selected in the SCAN setting, the marker is not displayed.  To display the marker, select a setting other than NATIVE.</p>

Submenu	Setting
MARKER SELECT	<p>Selects the aspect ratio according to the film, when the frame of the film is displayed on the screen.</p> <p><b>When 16:9 aspect ratio is selected with the button which the aspect function is assigned</b></p> <p>You can select from among 4:3, 15:9, 14:9, 13:9, 1.85:1, 2.35:1, 1.85:1 &amp; 4:3 and OFF.</p> <p><b>When 4:3 aspect ratio is selected with the button which the aspect function is assigned</b></p> <p>You can select 16:9 or OFF.</p>
CENTER MARKER	Selects ON to display the center mark of the picture and OFF not to display.
SAFETY AREA	Selects the safe area size for the aspect ratio determined by the button to which the aspect function is assigned. You can select from OFF, 80%, 85%, 88%, 90% and 93%. When the marker is displayed, the safe area for the marker is displayed.
MARKER LEVEL	<p>Sets the luminance to display the MARKER SELECT, CENTER MARKER and SAFETY AREA. You can select from among 1 to 3. When the setting is low, the marker appears dark.</p>
MARKER MAT	<p>Selects whether you put mat on the outside of the marker display.</p> <ul style="list-style-type: none"> <li>• <b>OFF:</b> No mat is put.</li> <li>• <b>HALF:</b> Gray mat is put.</li> <li>• <b>BLACK:</b> Black mat is put.</li> </ul>

## T/C (time code) DISPLAY SETTING

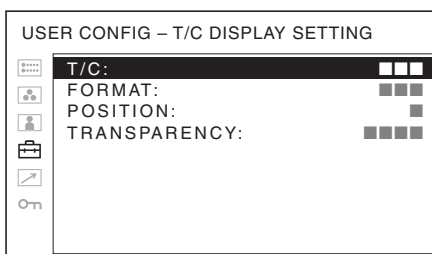

Submenu	Setting
T/C	Selects ON to display the time code display and OFF not to display.
FORMAT	<p>Sets the time code format.</p> <ul style="list-style-type: none"> <li>• <b>VITC:</b> To display the time code in VITC format.</li> <li>• <b>LTC:</b> To display the time code in LTC format.</li> </ul>

Submenu	Setting
POSITION	<p>Sets the position of the time code display. You can select between 1 and 2.</p> <ul style="list-style-type: none"> <li>• <b>1:</b> Top</li> <li>• <b>2:</b> Bottom</li> </ul>
<p><b>Note</b></p> <p>Settings cannot be changed when IMD is activated. The POSITION setting in IMD SETTING has a priority over that in T/C DISPLAY SETTING when the same settings are made in the two menus.</p>	
TRANSPARENCY	<p>Selects BLACK or HALF (transparent) for the background of T/C display.</p> <ul style="list-style-type: none"> <li>• <b>BLACK:</b> The background becomes black. Displayed image is hidden behind the background.</li> <li>• <b>HALF:</b> The background becomes transparent. Displayed image appears under the T/C display.</li> </ul>

## IMD (in-monitor display) SETTING

The monitor supports “TSL UMD Protocol - V5.00” provided by Television System LTD.

Tally 1 and tally 2 lamp colors, text colors and text display brightness can be set in the setting menu.

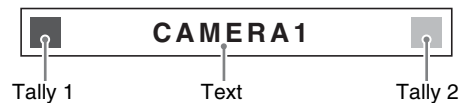

### Notes

- Set values to “0x0000” in SCREEN and INDEX of TSL protocol setting before displaying IMD.
- The monitor displays English alphabet, numbers, symbolic codes and Japanese letters (i.e. Hiragana and Katakana). Certain symbols cannot be displayed.
- Up to 16 characters are displayed in English and Japanese. A voiced sound mark in Japanese is counted as one character.

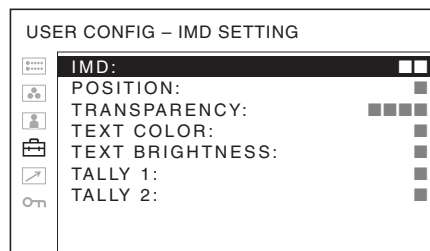

Submenu	Setting
IMD	Selects ON to activate IMD and OFF to turn it off.
POSITION	Sets the position of IMD. You can select between 1 and 2. <ul style="list-style-type: none"> <li>• 1: Top</li> <li>• 2: Bottom</li> </ul>
TRANSPARENCY	Selects BLACK or HALF for the background of IMD. <ul style="list-style-type: none"> <li>• <b>BLACK:</b> The background is black. Displayed image is hidden behind the background.</li> <li>• <b>HALF:</b> The background is transparent. Displayed image can be seen indistinctly behind the IMD display.</li> </ul>
TEXT COLOR	Selects the color of text displayed in IMD. Selecting “0 (commanded color)” sets the same color as set in TSL command. Selecting from 1 and 8 sets the following colors, regardless of the command setting. <ul style="list-style-type: none"> <li>• 0: Commanded color</li> <li>• 1: White</li> <li>• 2: Red</li> <li>• 3: Green</li> <li>• 4: Blue</li> <li>• 5: Yellow</li> <li>• 6: Cyan</li> <li>• 7: Magenta</li> <li>• 8: Amber</li> </ul>
TEXT BRIGHTNESS	Selects brightness of text displayed in IMD. Selecting “0 (commanded brightness)” sets the brightness same as set in TSL command. Selecting from between 1 and 3 sets the following brightness, regardless of the command setting. <ul style="list-style-type: none"> <li>• 0: Commanded brightness</li> <li>• 1: 100%</li> <li>• 2: 50%</li> <li>• 3: 14%</li> </ul>
TALLY 1	Selects the color of tally 1 lamp displayed in IMD. Selecting “0 (commanded color)” sets the same color as set in TSL command. Selecting from 1 and 8 sets the following colors, regardless of the command setting. <ul style="list-style-type: none"> <li>• 0: Commanded color</li> <li>• 1: White</li> <li>• 2: Red</li> <li>• 3: Green</li> <li>• 4: Blue</li> <li>• 5: Yellow</li> <li>• 6: Cyan</li> <li>• 7: Magenta</li> <li>• 8: Amber</li> </ul>

Submenu	Setting
TALLY 2	Selects the color of tally 2 lamp displayed in IMD. Selecting “0 (commanded color)” sets the same color as set in TSL command. Selecting from 1 and 8 sets the following colors, regardless of the command setting. <ul style="list-style-type: none"> <li>• 0: Commanded color</li> <li>• 1: White</li> <li>• 2: Red</li> <li>• 3: Green</li> <li>• 4: Blue</li> <li>• 5: Yellow</li> <li>• 6: Cyan</li> <li>• 7: Magenta</li> <li>• 8: Amber</li> </ul>

## WFM/ALM (waveform monitor and audio level meter) DISPLAY SETTING

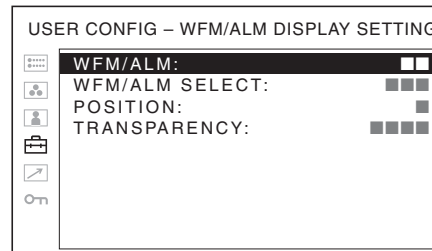

Submenu	Setting
WFM/ALM	Selects ON to display the WFM/ALM display and OFF not to display. <p><b>Note</b></p> When the WFM/ALM display is enabled, the marker display is not available.
WFM/ALM SELECT	<ul style="list-style-type: none"> <li>• <b>WFM:</b> A waveform monitor is displayed.</li> <li>• <b>ALM:</b> An audio level meter is displayed.</li> </ul> When WFM is selected, the waveform and audio level are displayed. When ALM is selected, the audio level is displayed in eight channels. The audio levels of WFM or ALM are displayed when SDI signal is input. Select the displayed audio level channels in SDI AUDIO SETTING. The indications of the waveform (only when WFM is selected) and audio level signify as illustrated below, although the percentage of the waveform, units and values of the scale for the audio level do not appear on the display.

Submenu	Setting
---------	---------

When WFM is selected

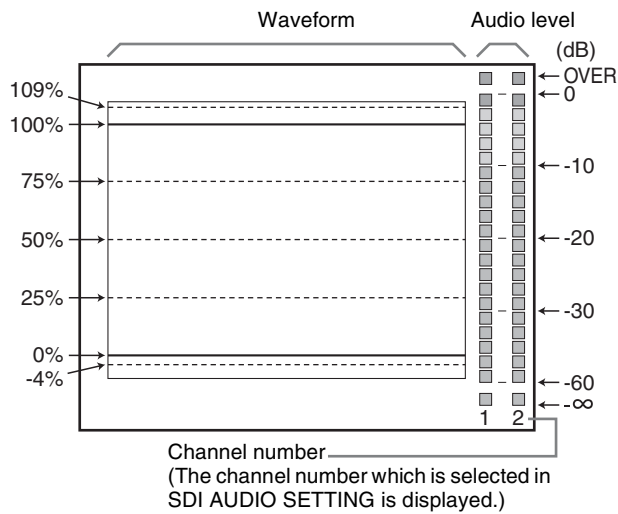

When ALM is selected

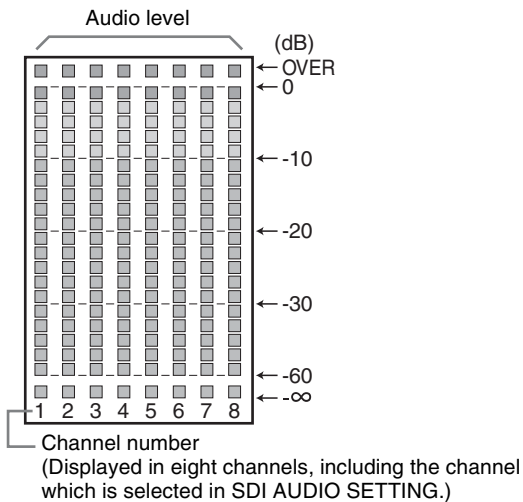

POSITION	<p>Sets the position of the WFM/ALM display. You can select from among 1 to 4.</p> <ul style="list-style-type: none"> <li>• <b>1:</b> Bottom left</li> <li>• <b>2:</b> Bottom right</li> <li>• <b>3:</b> Top right</li> <li>• <b>4:</b> Top left</li> </ul>
TRANSPARENCY	<p>Selects from black and half (transparent) for the background of the WFM/ALM display.</p> <ul style="list-style-type: none"> <li>• <b>BLACK:</b> The background is black. Displayed image is hidden behind the background.</li> <li>• <b>HALF:</b> The background is transparent. Displayed image can be seen indistinctly behind the WFM/ALM display.</li> </ul>

## FUNCTION BUTTON SETTING

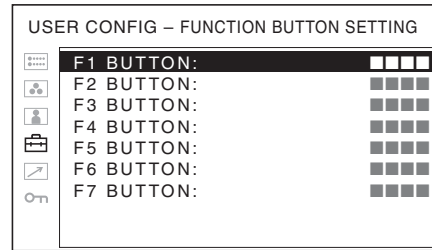

Submenu	Setting
F1 BUTTON to F7 BUTTON	<p>Assigns the function to the function buttons of the front panel and turns the function on or off.</p> <p>You can assign the function from among SCAN, ASPECT, BLUE ONLY, MONO, MARKER, I/P MODE and WFM/ALM.</p> <p><b>Factory setting</b></p> <ul style="list-style-type: none"> <li>• <b>F1 button:</b> BRIGHTNESS</li> <li>• <b>F2 button:</b> CONTRAST</li> <li>• <b>F3 button:</b> CHROMA</li> <li>• <b>F4 button:</b> SCAN</li> <li>• <b>F5 button:</b> H/V DELAY</li> <li>• <b>F6 button:</b> VOLUME</li> <li>• <b>F7 button:</b> I/P MODE</li> </ul>

### About the function assigned to the function button

#### SCAN

Press the button to change the scan size of the picture. With every press of the button for the 4:3 display, the picture switches in the sequence NORMAL scan → OVER scan → NATIVE. With every press of the button for the 16:9 display, the picture switches in the sequence NORMAL scan → OVER scan → FULL screen → NATIVE (see “Scan mode image” on page 30).

#### ASPECT

Press the button to set the aspect ratio of the picture, 4:3 or 16:9.

#### Note

LMD-1541W has a 15:9 screen ratio.

When the 16:9 signal is displayed, black bars appear in the upper and lower positions of the display. This is not a malfunction (see “Scan mode image” on page 30).

#### BLUE ONLY

Press the button to eliminate the red and green signals. Only blue signal is displayed as an apparent monochrome picture on the screen. This facilitates “chroma” and “phase” adjustments and observation of signal noise.

## MONO

Press the button to display a monochrome picture. When the buttons is pressed again, the monitor switches automatically to color mode.

## MARKER

Press the button to display the marker. Set the aspect marker in the MARKER SETTING menu (see page 26).

## H/V DELAY

Press the button to observe the horizontal and vertical sync signals at the same time.

## WFM/ALM

Press the button to display the WFM/ALM display. Set the WFM/ALM display setting in the WFM/ALM DISPLAY SETTING menu (see page 28).

## BRIGHTNESS

Press the button to display the adjustment screen and adjust the picture brightness. Press again to hide the adjustment screen. However, the picture brightness remains adjustable. Turn the menu selection control right to increase the brightness and turn left to decrease it.

## CONTRAST

Press the button to display the adjustment screen and adjust the picture contrast. Press again to hide the adjustment screen. However, the picture contrast remains adjustable. Turn the menu selection control right to increase the contrast and turn left to decrease it.

## CHROMA

Press the button to display the adjustment screen and adjust the color intensity. Press again to hide the adjustment screen. However, the color intensity remains adjustable. Turn the menu selection control right to increase the intensity and turn left to decrease it.

## VOLUME

Press the button to display the adjustment screen and adjust the volume. Press again to hide the adjustment screen. However, the volume remains adjustable. Turn the menu selection control right to increase the volume and turn left to decrease it.

## I/P MODE

Press the button to set the delay by the picture processing to the minimum level when interlace signal is input. The mode switches in the sequence INTER-FIELD → FIELD MERGE → LINE DOUBLER with every press of the button (see I/P MODE on page 26).

## PHASE

Press the button to display the adjustment screen and adjust the color tones. Press again to hide the adjustment screen. However, the color tones remain adjustable.

Turn the menu selection control right to increase the green tone and turn left to increase the purple tone.

## APERTURE

Press the button to display the adjustment screen and adjust the picture sharpness. Press again to hide the adjustment screen. However, the picture sharpness remains adjustable. Turn the menu selection control right to make the picture sharper and turn left to make the picture softer.

## CAMERA FOCUS

Press the button to confirm the camera focus. An image with sharpened edges is displayed.

## T/C

Press the button to display the time code display. Adjust the settings for the time code display in T/C DISPLAY SETTING (see page 27).

## IMD

Press the button to display IMD. Adjust the settings for the IMD display in IMD SETTING (see page 27).

## Scan mode image

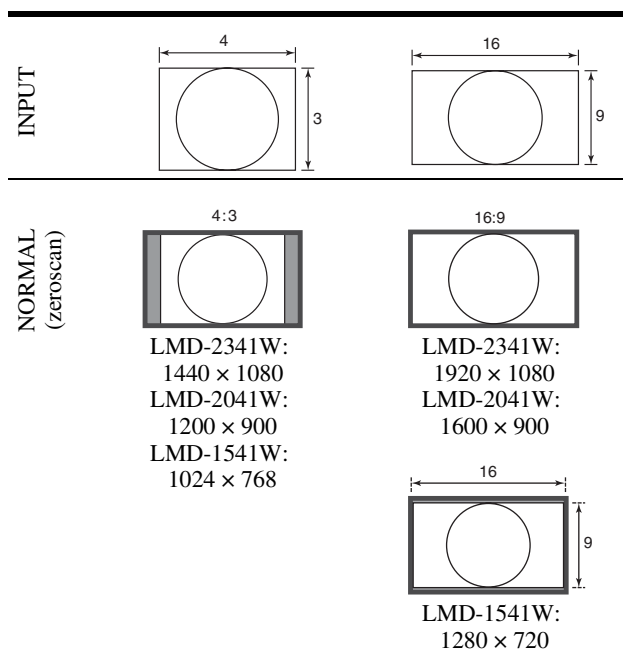

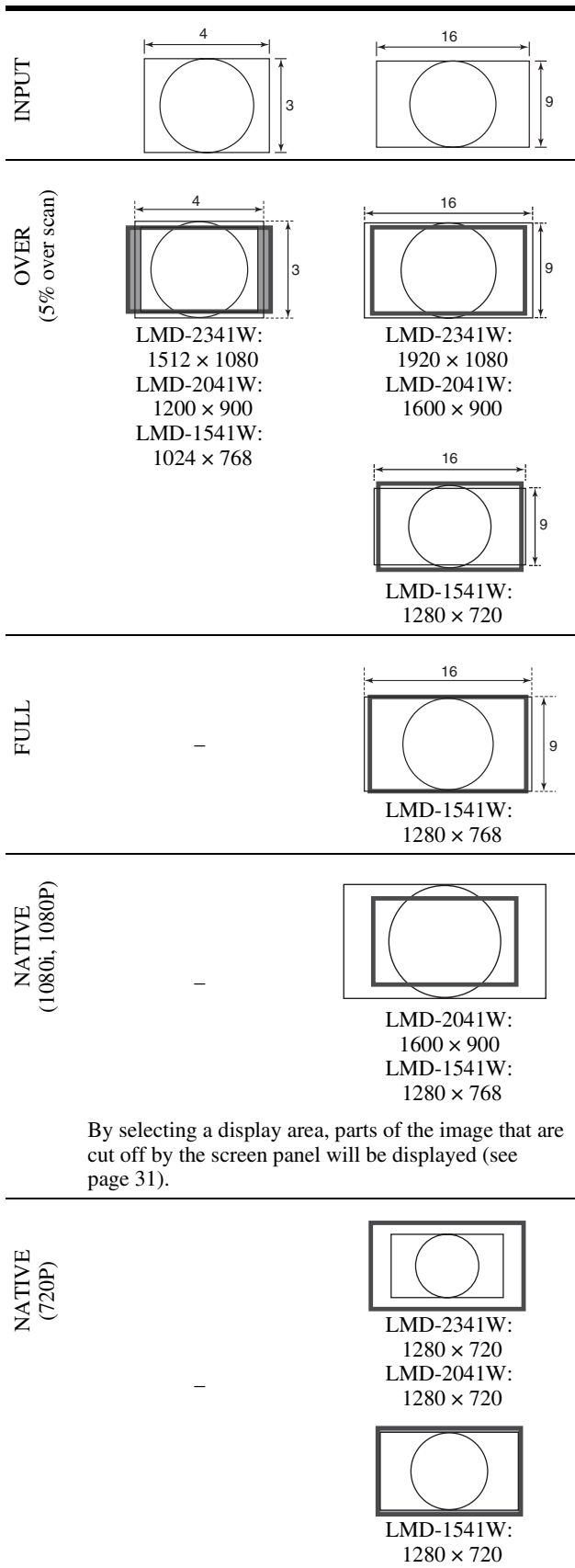

By selecting a display area, parts of the image that are cut off by the screen panel will be displayed (see page 31).

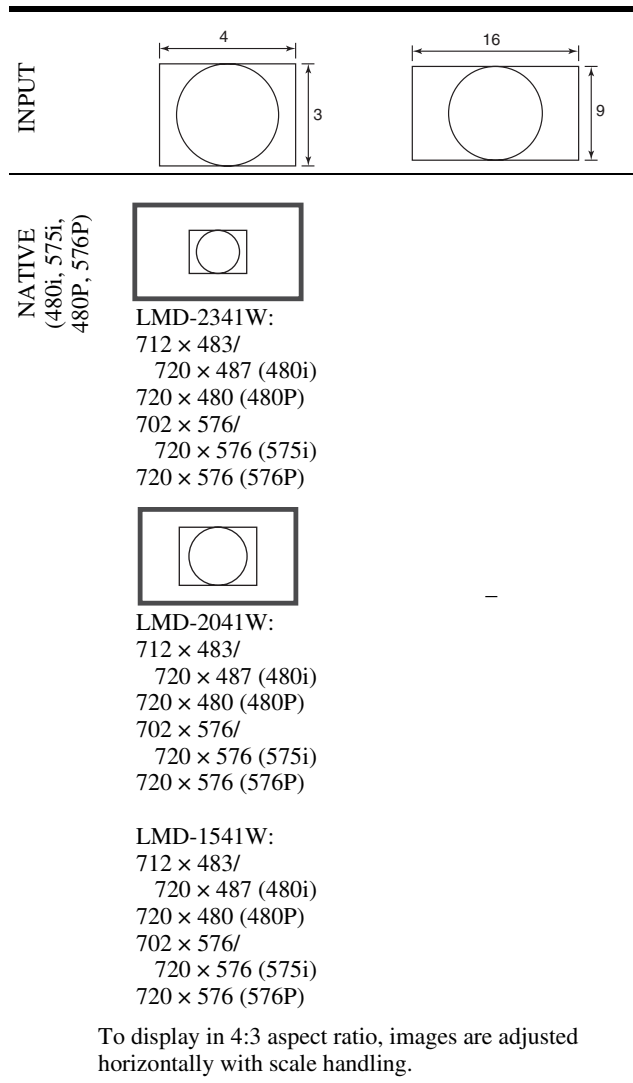

### Selecting a display area (LMD-2041W/ LMD-1541W)

While selecting NATIVE in the SCAN modes with 1080i or 1080P input signal, parts of the image are cut off by the screen panel. Those parts can be displayed by selecting the following display areas: center, top left, top right, bottom right and bottom left. The central area of the image is automatically framed when you select NATIVE.

#### To select a display area

- 1 Press the function button to which the SCAN function is assigned and select NATIVE. The central part of the image will be displayed.
- 2 Turn the menu selection control to select the area to magnify. The areas you select will be toggled in the

following order (turning the control in a clockwise direction).

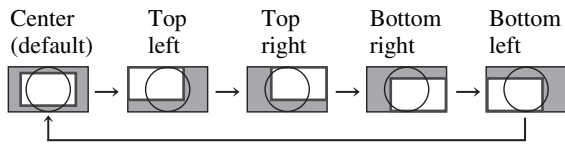

**Note**

Changing input signals or formats automatically sets the magnified area to the center (default).

- To return to standard viewing mode, press the function button again.

### AUDIO SETTING

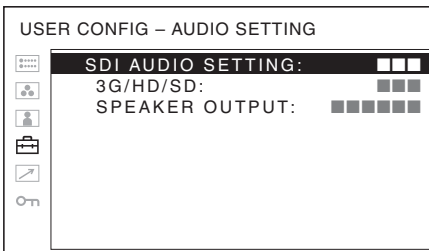

Submenu	Setting
SDI AUDIO SETTING	<p>Sets the audio channel when SDI signal is input.</p> <ul style="list-style-type: none"> <li><b>3G/HD/SD:</b> Selects from among channels CH1 to CH16, odd channel + even channel (CH1+CH2, CH3+CH4...CH15+CH16) and OFF.</li> </ul> <p>You can display the L/R audio levels of the selected channels on the display when the WFM/ALM display is enabled (see WFM/ALM display when the WFM/ALM display is enabled (see WFM/ALM (waveform monitor and audio level meter) DISPLAY SETTING on page 28).</p> <ul style="list-style-type: none"> <li><b>SPEAKER OUTPUT:</b> Select an audio format to output from speakers, headphone jack, and AUDIO OUT connector. <ul style="list-style-type: none"> <li><b>EMBEDDED:</b> Outputs an audio signal embedded in SDI.</li> <li><b>ANALOG:</b> Outputs an audio signal that comes from the AUDIO IN connector.</li> </ul> </li> </ul>

### REMOTE menu

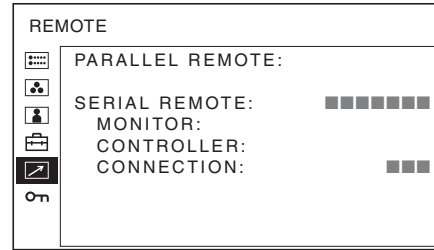

### PARALLEL REMOTE

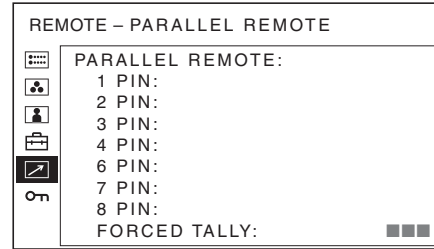



Submenu	Setting
PARALLEL REMOTE	<p>Selects the PARALLEL REMOTE connector pins for which you want to change the function. You can assign various functions to 1 to 4 pins and 6 to 8 pins. The following lists the functions you can assign to the pins.</p> <ul style="list-style-type: none"> <li>---- (“----”): No function is assigned.)</li> <li>• COMPOSITE</li> <li>• HDMI</li> <li>• SDI 2</li> <li>• SDI 1</li> <li>• WFM/ALM</li> <li>• OVERSCAN</li> <li>• FULL</li> <li>• NORMAL</li> <li>• NATIVE</li> <li>• 4:3</li> <li>• 16:9</li> <li>• TALLY R</li> <li>• TALLY G</li> <li>• BLUE ONLY</li> <li>• MONO</li> <li>• H/V DELAY</li> <li>• 16:9 MARKER</li> <li>• 15:9 MARKER</li> <li>• 14:9 MARKER</li> <li>• 13:9 MARKER</li> <li>• 1.85:1 MARKER</li> <li>• 2.35:1 MARKER</li> <li>• 1.85:1 &amp; 4:3 MARKER</li> <li>• 4:3 MARKER</li> <li>• CENTER MARKER</li> <li>• MARKER MAT HALF</li> <li>• MARKER MAT BLACK</li> <li>• SAFE AREA 80%*</li> <li>• SAFE AREA 85%*</li> <li>• SAFE AREA 88%*</li> <li>• SAFE AREA 90%*</li> <li>• SAFE AREA 93%*</li> </ul> <p>* Only LMD-2041W allows for setting.</p>

**Notes**

- If you use the PARALLEL REMOTE function, you need to connect cables. For more details, see page 37.
- Set MARKER ENABLE (page 26) to ON to control the aspect marker and center marker.

Submenu	Setting
FORCED TALLY	<p>The tally lamp function is forcibly assigned to 7 pin and 8 pin of the PARALLEL REMOTE connector. Selecting ON assigns tally lamp green to 7 pin and tally lamp red to 8 pin.</p> <ul style="list-style-type: none"> <li>• <b>ON</b>: Forcibly assigns the tally lamp function.</li> <li>• <b>OFF</b>: The tally lamp function is not forcibly assigned.</li> </ul>

**Note**

When OFF is selected, any listed functions can be assigned to 7 and 8 pins. Selecting ON with any function other than the tally lamp assigned to 7 and 8 pins will ignore this setting, and the tally lamp is forcibly assigned to 7 and 8 pins instead.

## SERIAL REMOTE

Submenu	Setting
SERIAL REMOTE	<p>Selects the mode to be used.</p> <ul style="list-style-type: none"> <li>• <b>OFF</b>: SERIAL REMOTE does not function.</li> <li>• <b>ETHERNET</b>: The monitor is controlled by the command of Ethernet.</li> <li>• <b>BKM-15R/16R</b>: Sets BKM-15R/16R.</li> </ul>
MONITOR	<p>Sets the monitor setting.</p> <p><b>MONITOR ID</b>: Sets the ID of the monitor.</p> <p><b>GROUP ID</b>: Sets the group ID of the monitor.</p> <p><b>IP ADDRESS</b>: Sets the IP address.</p> <p><b>SUBNET MASK</b>: Sets the subnet mask. (255.255.255.000)</p> <p><b>DEFAULT GATEWAY</b>: Sets the default gateway on or off.</p> <p><b>ADDRESS</b>: Sets the default gateway.</p> <p><b>CANCEL</b>: Selects to cancel the setting.</p> <p><b>CONFIRM</b>: Selects to save the setting.</p>
CONTROLLER	<p>Sets the address of the remote controller.</p> <p><b>IP ADDRESS</b>: Sets the IP address.</p> <p><b>SUBNET MASK</b>: Sets the subnet mask. (255.255.255.000)</p> <p><b>DEFAULT GATEWAY</b>: Sets the default gateway on or off.</p> <p><b>ADDRESS</b>: Sets the default gateway.</p> <p><b>CANCEL</b>: Selects to cancel the setting.</p> <p><b>CONFIRM</b>: Selects to save the setting.</p>
CONNECTION	<p>Sets the connection of the monitor and the controller.</p> <p><b>PEER TO PEER</b>: for one to one connection</p> <p><b>LAN</b>: for connection via a network</p>

## KEY INHIBIT menu

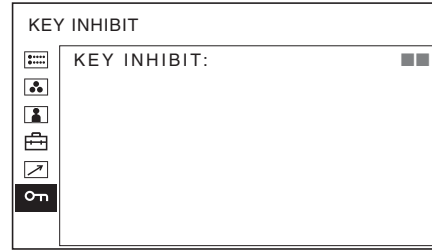

You can lock the setting so that they cannot be changed by an unauthorized user.

Select OFF or ON.

If you set to ON, all items are displayed in black, indicating the items are locked.

# Troubleshooting

This section may help you isolate the cause of a problem and as a result, eliminate the need to contact technical support.

- **The unit cannot be operated** → The key protection function works. Set the KEY INHIBIT setting to OFF in the KEY INHIBIT menu.  
Or, a function that does not work is assigned. Press the RETURN button to check the assigned functions.
- **The black bars appear at the upper and lower positions of the display** → When the signal aspect ratio is different from that of the panel, the black bars appear. This is not a failure of the unit.
- **Adjustments and settings cannot be made** → Adjustments and settings may not be possible depending on the input signals and the status of the unit. See “Input Signals and Adjustable/Setting Items” (page 12).

# Specifications

## Picture Performance

Panel	a-Si TFT Active Matrix LCD
Picture size (diagonal)	LMD-2341W: 23.0-type LMD-2041W: 20.0-type LMD-1541W: 15.3-type
Effective Picture size (H × V)	LMD-2341W: 509.1 × 286.4 mm (20 <sup>1</sup> / <sub>8</sub> × 11 <sup>3</sup> / <sub>8</sub> inches) LMD-2041W: 442.8 × 249.1 mm (17 <sup>1</sup> / <sub>2</sub> × 9 <sup>7</sup> / <sub>8</sub> inches) LMD-1541W: 334.1 × 200.5 mm (13 <sup>1</sup> / <sub>4</sub> × 8 inches)
Resolution (H × V)	LMD-2341W: 1920 × 1080 pixel LMD-2041W: 1600 × 900 pixel LMD-1541W: 1280 × 768 pixel
Aspect	LMD-2341W/LMD-2041W: 16:9 LMD-1541W: 15:9
Pixel efficiency	99.99%
Viewing angle (panel specification)	89°/89°/89°/89° (up/down/left/right, contrast > 10:1)
Normal scan	0%
Over scan	5%

## Input

Composite	BNC type (1) 1 Vp-p ±3 dB sync negative
SDI	BNC type (2)
HDMI	HDMI (1) (HDCP support)
Audio	Stereo mini jack (1) -5 dBu 47 kΩ or higher
Parallel remote	Modular connector 8-pin (1)
Serial remote (LAN)	RJ-45 (1) (Ethernet, 10BASE-T/ 100BASE-TX)
DC IN	LMD-2341W: DC 24 V Output impedance 0.05 Ω or less LMD-2041W/LMD-1541W: DC 12 V Output impedance 0.05 Ω or less

## Output

Composite	BNC type (1) Loop-through, with 75 Ω automatic terminal function
SDI	BNC type (1) Output signal amplitude: 800 mVp- p ±10% Output impedance: 75 Ω unbalanced
Audio monitor output	

Speaker (Built-in) Stereo mini jack (1)  
LMD-2341W/LMD-2041W: 1.0 W  
Monaural  
LMD-1541W: 0.5 W Monaural

## General

### Power requirements

LMD-2341W: AC 100 V to 240 V,  
0.8 A to 0.4 A, 50/60 Hz  
DC 24 V, 2.4 A  
LMD-2041W: AC 100 V to 240 V,  
0.8 A to 0.4 A, 50/60 Hz  
DC 12 V, 4.4 A  
LMD-1541W: AC 100 V to 240 V,  
0.8 A to 0.4 A, 50/60 Hz  
DC 12 V, 3.4 A

### Power consumption

LMD-2341W: Maximum: approx.  
70 W  
LMD-2041W: Maximum: approx.  
66 W  
LMD-1541W: Maximum: approx.  
50 W

### Inrush current

LMD-2341W:  
(1) Maximum possible inrush current  
at initial switch-on (Voltage  
changes caused by manual  
switching):  
58 A peak, 0.3 A r.m.s. (240 V AC)  
(2) Inrush current after a mains  
interruption of five seconds  
(Voltage changes caused at zero-  
crossing):  
46 A peak, 0.2 A r.m.s. (240 V AC)  
LMD-2041W:  
(1) Maximum possible inrush current  
at initial switch-on (Voltage  
changes caused by manual  
switching):  
57 A peak, 0.3 A r.m.s. (240 V AC)  
(2) Inrush current after a mains  
interruption of five seconds  
(Voltage changes caused at zero-  
crossing):  
46 A peak, 0.2 A r.m.s. (240 V AC)  
LMD-1541W:  
(1) Maximum possible inrush current  
at initial switch-on (Voltage  
changes caused by manual  
switching):  
60 A peak, 0.3 A r.m.s. (240 V AC)  
(2) Inrush current after a mains  
interruption of five seconds  
(Voltage changes caused at zero-  
crossing):  
48 A peak, 0.2 A r.m.s. (240 V AC)

### Operating temperature

0 °C to 35 °C (32 °F to 95 °F)  
Recommended temperature: 20 °C to  
30 °C (68 °F to 86 °F)

### Operating humidity

30% to 85% (no condensation)

### Storage / transport temperature

-20 °C to +60 °C (-4 °F to +140 °F)

### Storage / transport humidity

0% to 90%

### Operating / storage / transport pressure

700 hPa to 1060 hPa

### Supplied accessories

AC power cord (1)  
AC plug holder (1)  
Control panel cover (1) (For LMD-  
2341W)  
Screws for control panel cover (3) (For  
LMD-2341W)  
Operating Instructions (1)  
CD-ROM (1)  
Using the CD-ROM Manual (1)  
Mounting bracket (2) (For LMD-  
2041W)  
Screws for mounting bracket (8) (For  
LMD-2041W)  
Stand (2) (For LMD-2041W)  
Screws for stand (6) (For LMD-  
2041W)

### Optional accessories

Mounting bracket  
MB-534 (For LMD-1541W)  
Monitor stand  
SU-561  
SU-562 (For LMD-1541W)

Design and specifications are subject to change without  
notice.

#### Note

Always verify that the unit is operating properly before  
use. SONY WILL NOT BE LIABLE FOR  
DAMAGES OF ANY KIND INCLUDING, BUT  
NOT LIMITED TO, COMPENSATION OR  
REIMBURSEMENT ON ACCOUNT OF THE LOSS  
OF PRESENT OR PROSPECTIVE PROFITS DUE  
TO FAILURE OF THIS UNIT, EITHER DURING  
THE WARRANTY PERIOD OR AFTER  
EXPIRATION OF THE WARRANTY, OR FOR  
ANY OTHER REASON WHATSOEVER.

## Pin assignment

### PARALLEL REMOTE connector

Modular connector  
(8-pin)

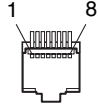

Pin number	Functions
1	Designating SDI 1 input signal
2	Designating HDMI input signal
3	Designating composite input signal
4	TALLY G
5	GND
6	TALLY R
7	OVERSCAN
8	NORMAL

You can allocate functions using the REMOTE menu (see page 32).

### Wiring required to use the Remote Control

Connect the function you want to use with a Remote Control to the Ground (Pin 5).

### Available signal formats

The unit is applicable to the following signal formats.

System	Compo site	SD/HD	3G	HDMI
575/50I (PAL)	○	○	–	○
480/60I (NTSC)* <sup>3</sup>	○	○	–	○
576/50P	–	–	–	○
480/60P* <sup>3</sup>	–	–	–	○
640 × 480/60P* <sup>3</sup>	–	–	–	○
1080/24PsF* <sup>1</sup> * <sup>3</sup>	–	○	–	–
1080/25PsF* <sup>2</sup>	–	○	–	–
1080/24P* <sup>3</sup>	–	○	–	○
1080/25P	–	○	–	○
1080/30P* <sup>3</sup>	–	○	–	○
1080/50I	–	○	–	○
1080/60I* <sup>3</sup>	–	○	–	○
720/50P	–	○	–	○* <sup>4</sup>
720/60P* <sup>3</sup>	–	○	–	○* <sup>4</sup>
1080/50P	–	–	○* <sup>5</sup>	○* <sup>4</sup>
1080/60P* <sup>3</sup>	–	–	○* <sup>5</sup>	○* <sup>4</sup>

○ : Adjustable/can be set

– : Not adjustable/cannot be set

\*1 The format on the screen is displayed as 1080/48I.

\*2 The format on the screen is displayed as 1080/50I.

\*3 The frame rate is also compatible with 1/1.001.

\*4 Also available when a DVI signal is input with a DVI conversion cable connected to the HDMI IN connector.

\*5 10 bit 4:2:2 YCbCr is supported.

### Applicable DVI input signals from PC

When a DVI signal is input to the HDMI IN connector using a DVI conversion cable

Resolution	Dot clock (MHz)	fH (kHz)	fV (Hz)
640 × 480	25.175	31.5	60
1280 × 768	68.250	47.4	
1280 × 1024	108.000	64.0	
1360 × 768	85.500	47.7	
1440 × 900	88.750	55.5	
1680 × 1050	119.000	64.7	

#### Note

The sides of the displayed picture may be hidden depending on the input signal.

# Dimensions

## LMD-2341W

### Front (with optional monitor stand SU-561)

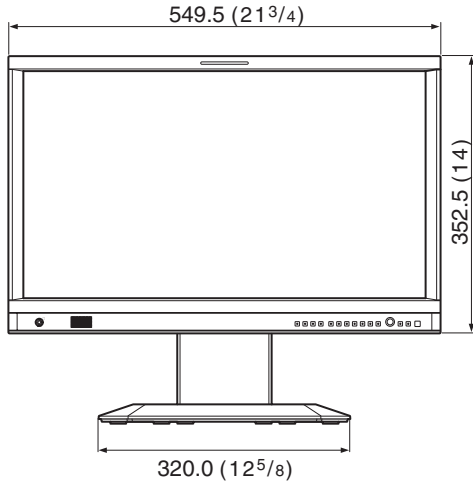

### Rear

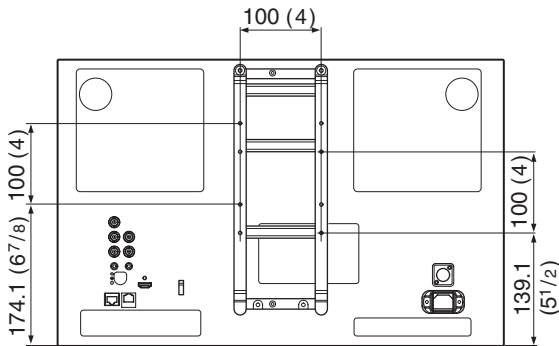

### Side (with optional monitor stand SU-561)

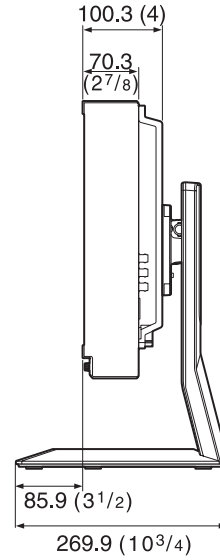

Unit: mm (inches)

### Mass Approx.:

9.2 kg (20 lb 4.5 oz) (without a monitor stand)

11.3 kg (24 lb 15 oz) (with monitor stand SU-561)

## LMD-2041W

### Front (with the supplied stand)

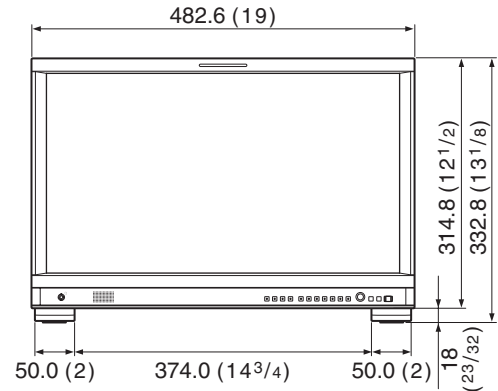

**Rear**

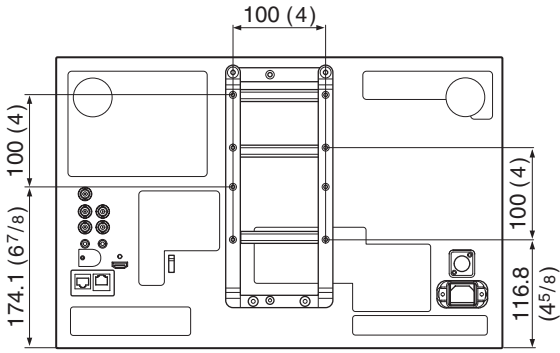

**Side (with the supplied stand)**

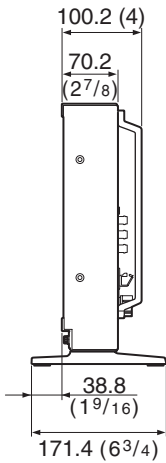

**Front (with optional monitor stand SU-561)**

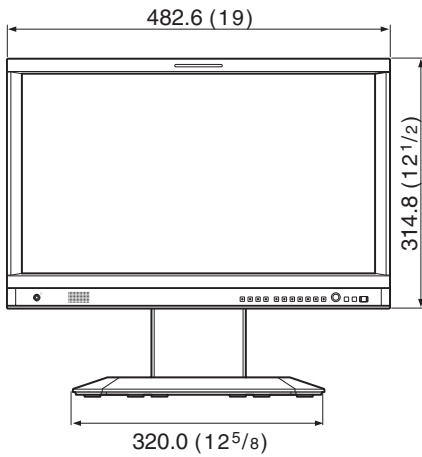

**Side (with optional monitor stand SU-561)**

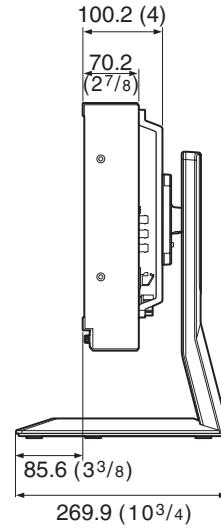

Unit: mm (inches)

**Mass Approx.:**

- 6.7 kg (14 lb 12 oz) (without a monitor stand)
- 6.9 kg (15 lb 3.4 oz) (with the supplied stand)
- 8.8 kg (19 lb 6.4 oz) (with monitor stand SU-561)

**LMD-1541W**

**Front (with optional monitor stand SU-562)**

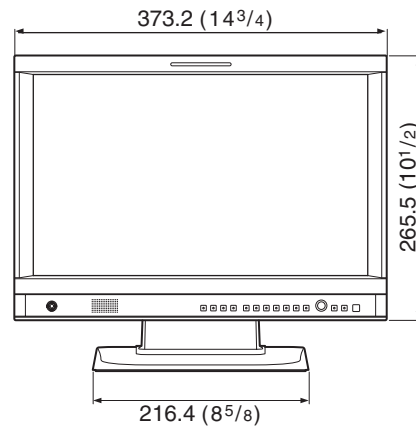

**Rear (with optional monitor stand SU-562)**

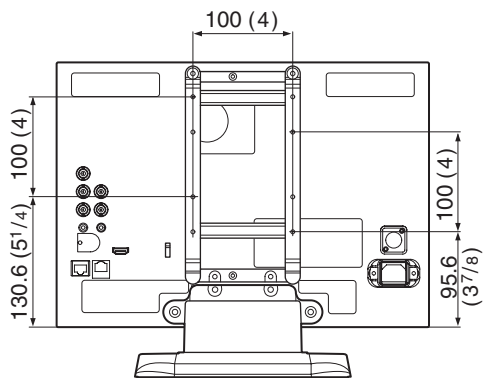

**Side (with optional monitor stand SU-562)**

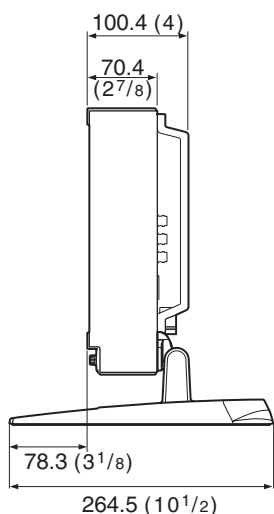

**Side (with optional monitor stand SU-561)**

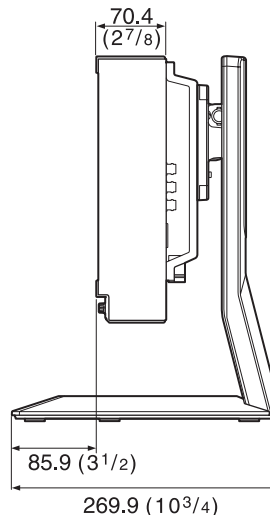

Unit: mm (inches)

**Mass Approx.:**

- 5.1 kg (11 lb 4.2 oz) (without a monitor stand)
- 6.8 kg (14 lb 16 oz) (with monitor stand SU-562)
- 7.2 kg (15 lb 14 oz) (with monitor stand SU-561)

**Front (with optional monitor stand SU-561)**

