

SAMPLING VECTOR SCOPE MONITOR VSM-100

Accurate video signal analysis and calibration has always been crucial to any live production.

Datavideo VSM-100 and VSM-200 waveform / vectorscope monitor series seamlessly integrate into a compact 19" rack system to ensure consistent and legal color and luminance video levels. At 2U, they are perfect for use in a production van or any space-limited setup.

DUAL SAMPLING VECTOR SCOPE MONITOR VSM-200

VSM-100 has a single waveform / vectorscope unit while VSM-200 features dual scopes. Both models come with two LCD screens, thus no external monitors are required; as such it's highly cost effective.

VSM-100



4.3" HD MONITOR

VECTOR SCOPE CONTROL PANEL

VSM-200



4.3" HD MONITOR

VECTOR SCOPE CONTROL PANEL

FEATURES

- VSM-100: one waveform / vectorscope unit with two 4.3-inch HD monitor screens
- VSM-200: two waveform / vectorscope unit with two 4.3-inch HD monitor screens
- Sampling Vectorscope
 - HD/SD-SDI input
 - HDMI and HD/SD-SDI output, SDI output can be assigned as video source loop out or vectorscope display
 - Auto-detect NTSC, PAL and HD signals
 - Support four analysis modes: Waveform, Vectorscope, Parade (YCrCb & RGB) and Histogram
 - Save and Recall traces for easy comparison of different video signals
 - Video input thumbnail with selectable 16:9/4:3 aspect ratio
 - Vectorscope reticle can be toggled between 75% and 100%
 - Waveform detail can be zoomed 20%, 40%, 60% and 100%
 - Adjusting Horizontal Delay to view parts of the waveform
- Support embedded audio with on-screen audio level meter for up to 8 selectable channels
- Monitor screens
 - Each monitor has one HDMI and one HD/SD-SDI input with loopthrough output
 - Auto-detect NTSC, PAL and HD input signal
 - Individual adjustments of Brightness, Contrast, Color Saturation and Back Light Level for each monitor
 - Support Blue Only function, Safe area marking and Timecode display
 - Support embedded audio on SDI, HDMI
 - Audio monitoring via on-screen audio level indicator and front panel headphone jacks
 - 4:3 & 16:9 display mode switching
- Standard 19-inch rack size, 2U height, easy for system integration

REAR VIEW

VSM-100

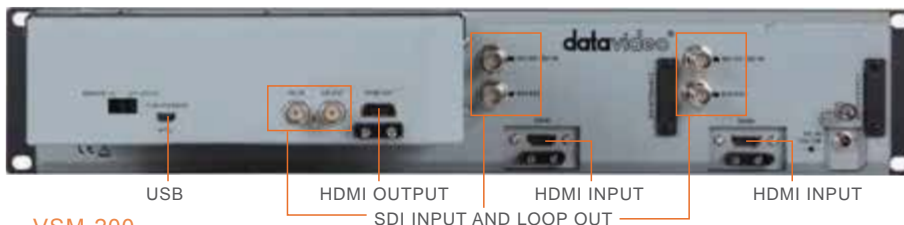

USB

HDMI OUTPUT

HDMI INPUT

HDMI INPUT

SDI INPUT AND LOOP OUT

VSM-200

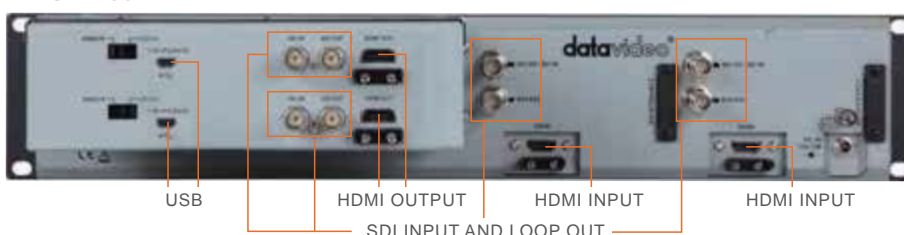

USB

HDMI OUTPUT

HDMI INPUT

HDMI INPUT

SDI INPUT AND LOOP OUT

VSM-100 CONNECTION DAIGRAM

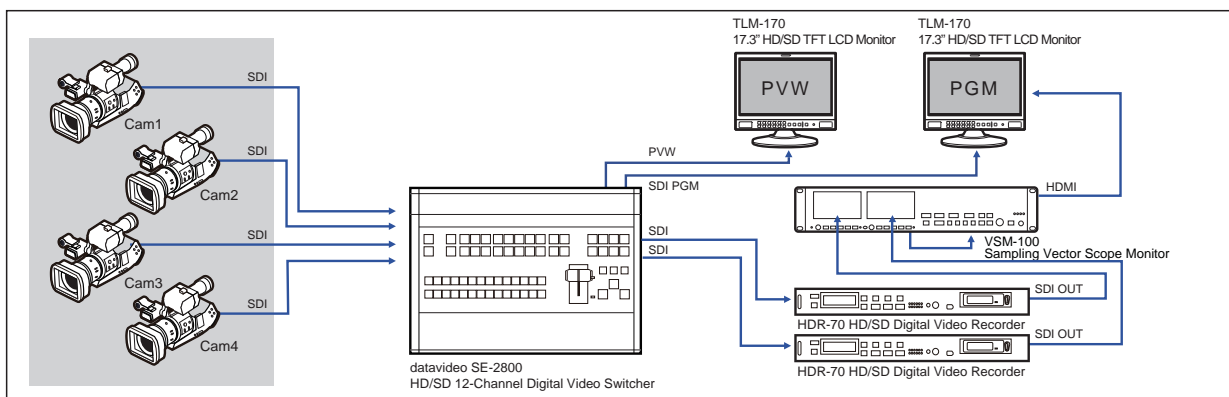

Camera signals are fed to a video switcher which main output is then connected to VSM-100. Director analyses and compares different signals through VSM-100 using Save/Recall Trace function. The result is communicated

to cameramen through intercom system to calibrate individual signals to achieve consistency. Two 4.3-inch screens can then be used to monitor recording signals to ensure final video quality.

VSM-200 CONNECTION DAIGRAM

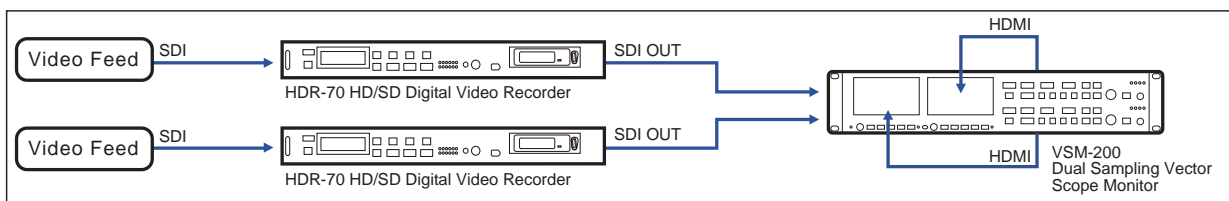

2 video signals are connected to 2 waveform / vectorscope units in VSM-200. Video test and analysis of each signal can be displayed on 2 built-in screens separately. Using a camera remote controller, such

as Datavideo MCU-100 or MCU-200, operators can adjust camera settings to achieve precise and matching black/white balance calibration, color saturation and luminance level for each video source.

SPECIFICATION

■ Vectorscope

- HD/SD-SDI input with embedded audio (up to 8 channels)
- HD/SD-SDI and HDMI (v1.1) output, all scope view in 720P regardless of input format
- SDI output can be set as video input loop out
- Support embedded audio on both SDI & HDMI up to 8 channels
- Audio monitoring through on-screen audio level indicator and headphone jack
- Four test modes: Waveform, Vectorscope, Parade (YCrCb & RGB) and Histogram
- Video sampling by Single Field or whole Frame

■ Monitor screens

- 4.3" TFT LCD, 480 x 272 pixel panel resolution, contrast 300:1, brightness 500 cd/m2 (typical)
- Viewing angle: Top: 50 deg / Bottom: 70 deg / Left: 70 deg / Right: 70 deg
- Supports HDMI and HD/SD-SDI (with loopthru) video
- Supports embeded audio with on-screen levels indicator
- Support Timecode display, safe area marking and blue only function

- Color temperature adjustment 9300, 7500, 6500, 5400 & User setting

■ Video Standard

- SMPTE 259M & SMPTE 292M
- Resolution:
 - SD: 720x480i, 720x576i
 - HD: 1280x720 50P/59.94P/60P
 - 1920x1080 50i/59.94i/60i
 - 1920x1080 24P/25P/30P (4.3" doesn't support)
- HDMI-RGB: 720x480i, 720x576i
- 1280x720 50P/59.94P/60P
- 1920x1080 50i/59.94i/60i

■ Dimensions

- Standard 19-inch rack size, 2U height

■ Power Supply

- VSM-100: DC 12V / 15W
- VSM-200: DC 12V / 19W