

---

## System 8

VHF Wireless System  
*Installation and Operation*

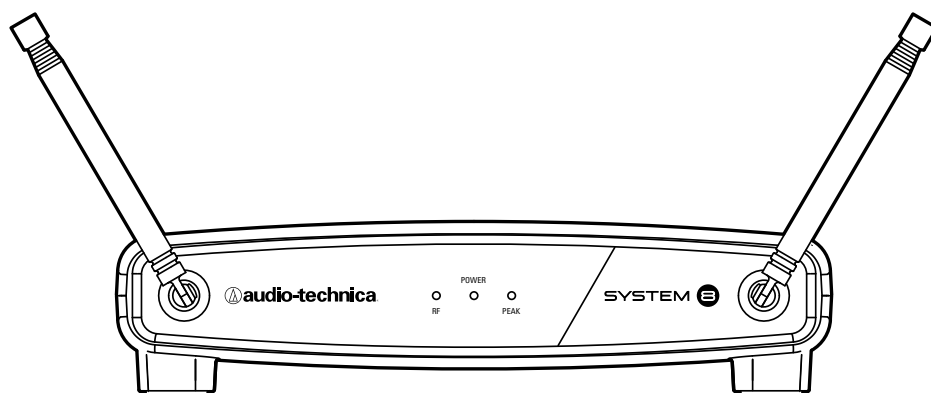

### **ATW-801**

*UniPak® Transmitter System*

### **ATW-801/G**

*Guitar System*

### **ATW-801/H**

*Headworn Microphone System*

### **ATW-801/H92**

*Miniature Headworn Microphone System*

### **ATW-801/H92-TH**

*Miniature (beige) Headworn Microphone System*

### **ATW-801/L**

*Lavalier Microphone System*

### **ATW-802**

*Handheld Microphone System*

## System 8 Installation and Operation

This device complies with part 15 of the FCC Rules. Operation is subject to the condition that this device does not cause harmful interference.

A copy of the declaration of conformity can be found on the internet at [www.audio-technica.com](http://www.audio-technica.com).

This device complies with INDUSTRY CANADA R.S.S. 210, en conformité avec IC: RSS-210/CNR210. Operation is subject to the following conditions: 1) This device may not cause harmful interference and 2) this device must accept any interference received, including interference which may cause undesired operation. Changes or modifications not expressly approved by Audio-Technica could void your authority to operate this equipment.

**CAUTION!** Electrical shock can result from removal of the receiver cover. Refer servicing to qualified service personnel. No user-serviceable parts inside. Do not expose to rain or moisture.

The circuits inside the receiver and transmitter have been precisely adjusted for optimum performance and compliance with federal regulations. Do not attempt to open the receiver or transmitter. To do so will void the warranty, and may cause improper operation.

**Notice to individuals with implanted cardiac pacemakers or AICD devices:**

Any source of RF (radio frequency) energy may interfere with normal functioning of the implanted device. All wireless microphones have low-power transmitters (less than 0.05 watts output) which are unlikely to cause difficulty, especially if they are at least a few inches away. However, since a "body-pack" mic transmitter typically is placed against the body, we suggest attaching it at the belt, rather than in a shirt pocket where it may be immediately adjacent to the medical device. Note also that any medical-device disruption will cease when the RF transmitting source is turned off. Please contact your physician or medical-device provider if you have any questions, or experience any problems with the use of this or any other RF equipment.

Thank you for choosing an Audio-Technica professional wireless system. You have joined thousands of other satisfied customers who have chosen our products because of their quality, performance and reliability. This wireless microphone system is the successful result of years of design and manufacturing experience.

Each System 8 professional VHF wireless system includes a receiver and either a body-pack transmitter or a handheld microphone/transmitter on a specific crystal-controlled frequency. ATW-801 UniPak® body-pack transmitter systems include models pre-packaged with either an AT-GcW guitar cable (G), a PRO 8HEcW headworn microphone (H), a PRO 92cW headworn microphone (H92), a PRO 92cW-TH headworn microphone (H92-TH), or a lavalier mic (L) for particular applications. All A-T Wireless Essentials® microphones and cables, available separately, are pre-terminated for use with any ATW-801 system.

Because System 8 packaging is designed to hold all versions of the system, some compartments in the carton may be intentionally left empty.

The ATW-R800 receiver includes a switching power supply that automatically adapts to changes in mains voltage.

The versatile ATW-T801 UniPak body-pack transmitter has both a high-impedance input for instruments, and a low-impedance input with bias connection for use with dynamic and electret condenser microphones. The ATW-T802 handheld transmitter features a unidirectional dynamic microphone element.

Both the body-pack and handheld transmitters use internal AA batteries and have Power/Mute switches and input Trim (level) adjustments.

### Receiver Installation

#### Location

For best operation the receiver should be at least 3' (1 m) above the ground and at least 3' (1 m) away from a wall or metal surface to minimize reflections. Keep the receiver antennas away from noise sources such as digital equipment, motors, automobiles and neon lights, as well as away from large metal objects. In multi-channel systems, position receivers at least 3' (1 m) apart and keep operating transmitters at least 6' (2 m) from the receivers to help assure maximum RF performance.

#### Output Connection

The receiver provides unbalanced, aux-level output from a 1/4" TS ("mono") phone jack; an output cable is not included. Use a shielded audio cable with 1/4" phone plug to connect the receiver's AF Out jack to the mixer/amplifier's aux-level input.

#### Power Connection

Connect the DC plug on the included AC power adapter to the DC power input on the back of the receiver. Secure the cord over the cord hook on the back of the receiver, to keep the plug from being detached by an accidental tug on the cord. Then plug the adapter into a standard 120 Volt 60 Hz AC power outlet.

(Note that the receiver has no power Off/On switch. The receiver will be energized whenever the power adapter is connected and plugged into the AC outlet. Unplug the power supply from the AC outlet when the system is not in use — both for safety, and to conserve energy.)

#### Antennas

A novel "dipole" antenna system on the receiver improves operation by providing a "ground" element in addition to the usual "signal" element. Position the two antennas at 90° in the form of a "V," or position the left ("signal") antenna vertically and the right ("ground") antenna horizontally, in the shape of an "L" (Fig. A). Use the position that performs better in your operating environment. Be certain to extend both antennas to their full 15" (38 cm) length by holding them at their bases and pulling out on their caps. Both antenna elements may be swiveled to the left and right, but do not attempt to rotate them in a screwing/unscrewing motion. To do so may damage the antenna and/or receiver. For best performance, locate the receiver so its antennas are in direct line-of-sight to the transmitter's likely operating position.

## Receiver Controls and Functions

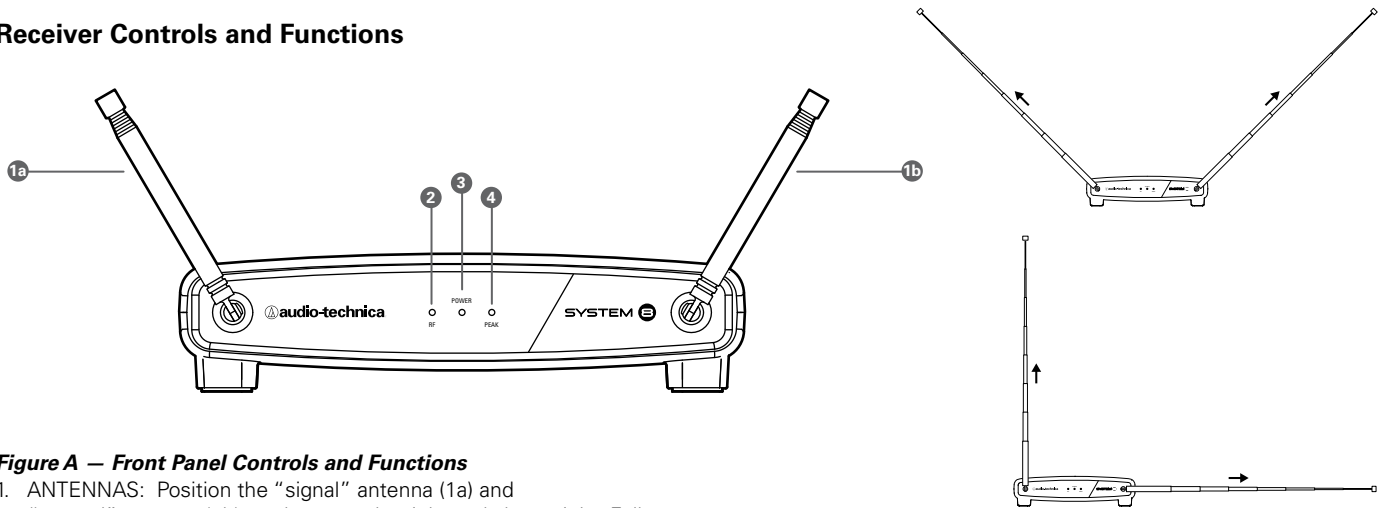

**Figure A – Front Panel Controls and Functions**

1. ANTENNAS: Position the “signal” antenna (1a) and “ground” antenna (1b) as shown to the right and above right. Fully extend both antennas by pulling on the endcaps.
2. RF INDICATOR: Lights to show presence of transmitter signal.
3. POWER INDICATOR: Lights when power is supplied to the receiver.
4. AF PEAK INDICATOR: Only lights when audio distortion is present at maximum modulation. Not affected by position of Volume control.

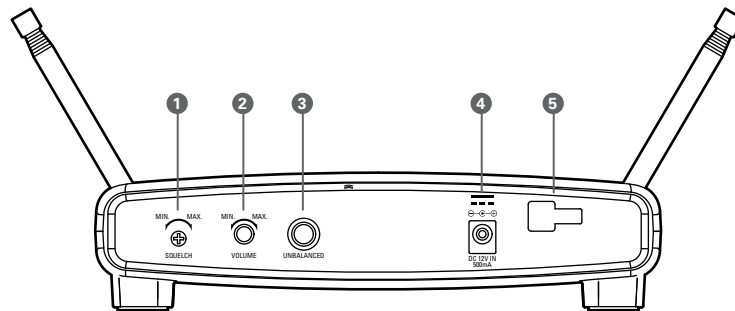

**Figure B – Rear Panel Controls and Functions**

1. SQUELCH CONTROL: Adjusts level of noise-muting circuit (preset at factory but can be adjusted as circumstances warrant).
2. VOLUME CONTROL: Adjusts the audio level at the 1/4" output jack. Does not affect AF Peak indicator.
3. AUDIO OUTPUT JACK: 1/4" TS (Tip-Sleeve) or “mono” phone jack. Use a shielded cable to connect to an unbalanced aux-level input of a mixer or amplifier.
4. POWER INPUT JACK: Connect the DC plug from the included AC adapter.
5. CORD HOOK: Loop the cord around the cord hook to keep the DC plug from pulling out accidentally.

## Transmitter Setup Controls and Functions

### Battery Selection and Installation

Two alkaline AA batteries are recommended. When inserting the battery, *observe correct polarity as marked inside the battery compartment.*

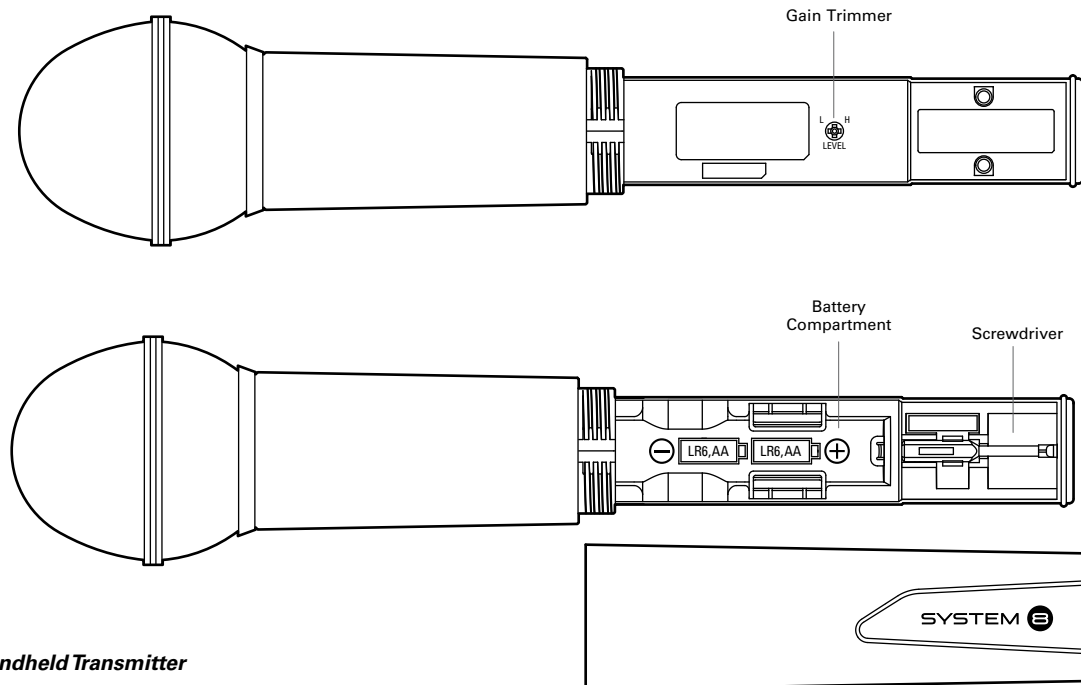

**Figure C – Handheld Transmitter**

### Handheld Transmitter Battery Installation

1. While holding the upper part of the transmitter body just below the ball-screen, unscrew the lower body cover and slide it off to expose the battery compartment (Fig. C).
2. Carefully insert two fresh AA alkaline batteries, observing polarity markings.
3. Screw the body back together. *Do not overtighten.*

### Handheld Transmitter Battery Condition Indicator

After the batteries are installed, press and hold the Power/Mute switch on the bottom of the handheld transmitter until the indicator LED turns green. If the indicator LED does not light up when the Power/Mute switch is pressed, the batteries are installed incorrectly or they are dead. The indicator LED will flash to show low-battery condition.

### Handheld Transmitter Mute Function

With the transmitter on, a slight touch of the power switch will toggle between muted and unmuted operation. Red indicator LED shows muted operation. Green indicator LED shows unmuted operation.

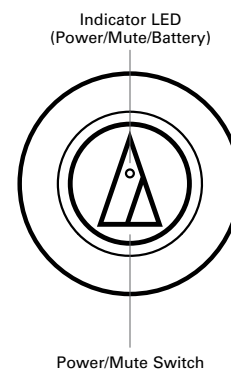

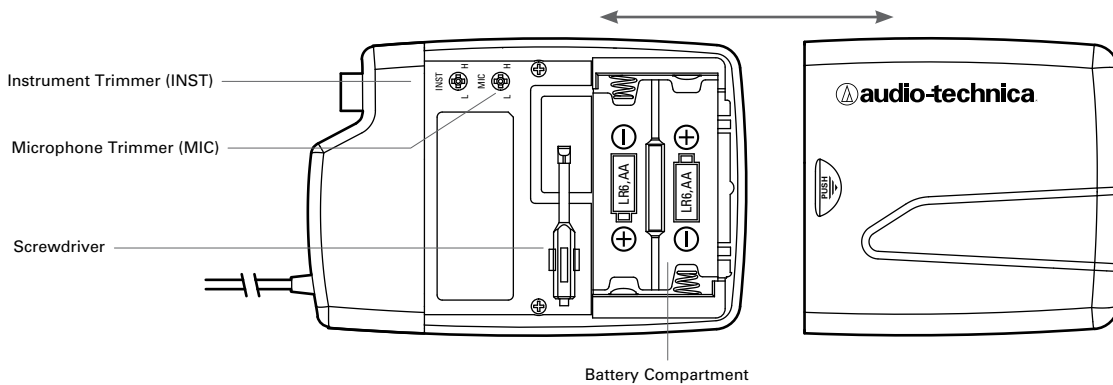

**Figure D — UniPak® Transmitter**

#### UniPak® Transmitter Battery Installation

1. Slide off the battery cover as shown in Figure D.
2. Carefully insert two fresh AA alkaline batteries, observing polarity markings.
3. Replace the battery cover (Fig. D).

#### UniPak® Transmitter Power/Mute/Battery Indicator

After the battery is installed, press and hold the power button until the indicator LED turns green (Fig. E). If the indicator LED does not light up when the power button is pressed, the batteries are installed incorrectly or they are dead. The indicator LED will flash to show low-battery condition.

#### UniPak® Transmitter Mute Function

With the transmitter on, a slight touch of the Power/Mute button will toggle between muted and unmuted operation. Red indicator LED shows muted operation. Green indicator LED shows unmuted operation.

#### UniPak® Transmitter Input Connection

Connect an audio input device (microphone or guitar cable) to the audio input connector on the top of the transmitter. A number of Audio-Technica professional microphones and cables are available separately, pre-terminated with a UniPak® input connector (see [www.audio-technica.com](http://www.audio-technica.com)).

#### UniPak® Transmitter Antenna

The UniPak® transmitter includes a permanently-attached flexible antenna. For best results, allow the antenna to hang freely and full length from the transmitter. If the received signal is marginal, experiment with different transmitter positions on your body or instrument; or try repositioning the receiver. Do not attempt to remove, replace or change the length of the transmitting antenna.

**Figure E — UniPak® Transmitter**

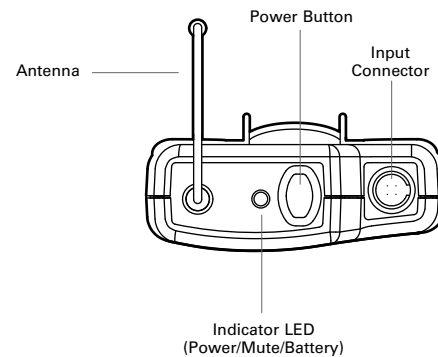

## System 8 Installation and Operation

### System Operation

Turn down the receiver volume control and the mixer/amplifier level before starting up the wireless system. Do not switch on the transmitter yet.

#### Receiver on...

Plug the power supply into an AC power source. The green Power indicator on the front panel will light.

#### Transmitter on...

When the transmitter is switched on, the receiver's amber RF signal indicator will light. The transmitters have a soft-touch power switch. When the switch is set to "Mute" (red indicator LED), the transmitter produces RF with no audio signal. When the switch is "On" (green indicator LED) the transmitter produces both RF and audio. Excessive audio input to the transmitter will cause the receiver's red AF Peak indicator to light.

#### Receiver Volume

Under typical operating conditions, the receiver's volume control should be turned all the way up, with overall system audio gain adjusted at the mixer or amplifier.

#### Input Level Adjustment

Input trimmer controls in the transmitters enable you to maximize performance for a particular microphone or guitar sensitivity, or to adjust for different acoustic input levels.

#### Adjusting Input Level - UniPak Transmitter

Slide the battery cover off the top part of transmitter and remove the screwdriver from its clip (Fig. D). Gently turn both the "MIC" (Mic Trimmer) and "INST" (Instrument Trimmer) controls to their full counterclockwise positions (toward "L").

##### • Microphone: Adjusting input level

Gently turn only the "MIC" (Mic Trimmer) control all the way up (clockwise, toward "H"). Check for excessive gain by speaking/singing into the microphone at typically loud levels while watching the receiver's AF Peak indicator. If the AF Peak indicator does light, turn the "MIC" control slightly counterclockwise until the AF Peak indicator no longer lights with maximum audio input to the transmitter.

##### • Guitar/Instrument: Adjusting input level

Gently turn only the "INST" (Instrument Trimmer) control all the way up (clockwise, toward "H"). Check for excessive gain by playing at typically loud levels while watching the receiver's AF Peak indicator. If the AF Peak indicator does light, turn the "INST" control slightly counterclockwise until the AF Peak indicator no longer lights with maximum instrument input to the transmitter. After adjusting input level, return the screwdriver to its clip and reinstall the battery cover. No further transmitter gain adjustments should be needed, as long as the input device and the acoustic input level are not changed.

#### Adjusting Input Level - Handheld Transmitter

Unscrew the lower body cover and slide it off, exposing the screwdriver and "LEVEL" (Gain Trimmer) control (Fig. C). Remove the screwdriver from its clip. Gently turn the "LEVEL" control to its full clockwise position (toward the side marked "H"), the factory setting. Check for excessive gain by speaking/singing into the microphone at typically-loud levels while watching the receiver's AF Peak indicator. If the AF Peak indicator does light, turn the "LEVEL" control slightly counterclockwise until the AF Peak indicator no longer lights with maximum audio input to the mic/transmitter.

Return the screwdriver to its clip and close and secure the lower body. No further transmitter gain adjustments should be needed, as long as the acoustic input does not change significantly.

**CAUTION!** *The small trimmer controls are delicate; use only the supplied screwdriver. Do not force the trimmers beyond their normal 190° range of rotation.*

*Return the screwdriver to its storage clip when not in use.*

### Ten Tips to Obtain the Best Results

1. Use only fresh alkaline batteries. Do not use "general purpose" (carbon-zinc) batteries.
2. Position the receiver so that it has the fewest possible obstructions between it and the normal location of the transmitter. Line-of-sight is best.
3. The transmitter and the receiver should be as close together as conveniently possible, but not less than 6' (2 m).
4. Do not place the receiver antennas within 3' (1 m) of another receiver or antenna.
5. The receiver antennas should be kept away from any metal.
6. A receiver cannot receive signals from two transmitters on the same frequency at the same time.
7. In the UniPak transmitter, the "MIC" or "INST" input control *not* in use should be set to *minimum*.
8. If the receiver output is set too low, the overall signal-to-noise ratio of the system may be reduced. Conversely, if the volume control of the receiver is set too high, it may over-drive the input of the mixer/amplifier, causing distortion. Adjust the output level of the receiver so the highest sound pressure level going into the microphone (or the loudest instrument playing level) causes no input overload in the mixer, and yet permits the mixer level controls to operate in their "normal" range (not set too high or too low). This provides the optimum signal-to-noise for the entire system.
9. Turn the transmitter off when not in use. Remove the battery if the transmitter is not to be used for a period of time.
10. Unplug the receiver from the AC outlet when the system is not in use.

### System Operating Frequencies

#### Frequency Selection

Each transmitter/receiver system operates on a single factory aligned, crystal-controlled frequency. Available frequencies are shown in the chart on the next page.

Operating frequency is specified by a two character code, such as "T2," in addition to the actual frequency in MHz. The frequency of each transmitter appears on a label on the outside of the unit. The frequency of each receiver appears on a label on the bottom of the unit and the frequency of each system appears on the outer carton. For future reference, please record them in the space provided on page 7.

#### RF Interference

Please note that wireless frequencies are shared with other radio services. According to Federal Communications Commission regulations, "Wireless microphone operations are unprotected from interference from other licensed operations within the band. If any interference is received by any Government or non-Government operation, the wireless microphone must cease operation..."

If you need assistance with operation or frequency selection, please contact your dealer or the Audio Solutions at Audio-Technica U.S.

Extensive wireless information also is available on the A-T Web site at [www.audio-technica.com](http://www.audio-technica.com).

## System Operating Frequencies

Application	Freq. Code	Freq. (MHz)
<ul style="list-style-type: none"> <li>Traveling frequencies: (Normally work anywhere in the U.S.A. and Canada.) Not all frequencies available in all areas outside the US. Please check with local regulations.</li> </ul>	T2	169.505
	T3	170.245
	T8	171.905
Systems on these frequencies may be combined for up to three simultaneous operating channels.		

For future reference, please record your system information here (the serial numbers appear near the screwdriver clip in each transmitter, and on the bottom of each receiver):

### Operating Frequency

Freq. Code    —    —

Frequency   — — — • — — — MHz

### Receiver

Model ATW-R800

Serial Number   — — — — —

### Transmitter

Model ATW-T80 <sub>1/2</sub>

Serial Number   — — — — —

## Specifications

### OVERALL SYSTEM

Operating Frequency	VHF highband, 169 MHz to 172 MHz
Modulation Mode	FM
Maximum Deviation	±10 kHz
Dynamic Range	≥90 dB (A-weighted), typical
Total Harmonic Distortion	<1% (at 1 kHz, ±10 kHz deviation)
Operating Range	200' (60 m) typical <i>Open range environment with no interfering signals</i>
Operating Temperature Range	40° F (4° C) to 110° F (43° C) <i>Battery performance may be reduced at very low temperatures</i>
Frequency Response	80 Hz to 13 kHz

### RECEIVER

Receiving System	Non-diversity, single-channel, dual antenna system
Image Rejection	50 dB minimum
RF Sensitivity	20 dBuV at 60 dB S/N ratio (50 ohms termination)
Nominal Output Level (1/4" (6.3 mm), unbalanced)	700 mV (1 kHz modulation, 10 kHz deviation, 100k ohm load)
Power Supply	100-240V AC (50/60 Hz) to 12V DC .5A (center positive) switched mode external power supply
Dimensions	7.48" (190.0 mm) W x 1.82" (46.2 mm) H x 5.06" (128.5 mm) D
Net Weight	11.8 oz (335 grams)
Accessories Included	Power supply

### UNIPAK® TRANSMITTER

RF Output Power	10 mW
Spurious Emissions	Following federal and national regulations
Input Connection	 Four-pin Locking Connector Pin 1: GND, Pin 2: INST INPUT, Pin 3: MIC INPUT, Pin 4: DC BIAS +9V
Batteries (not included)	Two 1.5V AA Alkaline
Battery Life	8 hours (alkaline) <i>Depending on battery type and use pattern</i>
Dimensions	2.76" (70.2 mm) W x 4.08" (103.7 mm) H x 0.98" (24.9 mm) D
Net Weight (without battery)	3.0 oz (84.5 grams)

### HANDHELD TRANSMITTER

RF Output Power	10 mW
Spurious Emissions	Following federal and national regulations
Batteries (not included)	Two 1.5V AA Alkaline
Battery Life	8 hours (alkaline) <i>Depending on battery type and use pattern</i>
Dimensions	9.91" (251.8 mm) long, 2.11" (53.5 mm) diameter
Net Weight (without battery)	9.2 oz (260 grams)
Accessory Included	AT8456a Quiet-Flex™ stand clamp

<sup>1</sup> In the interest of standards development, A.T.U.S. offers full details on its test methods to other industry professionals on request.



**Audio-Technica U.S., Inc.**  
1221 Commerce Drive, Stow, Ohio 44224 USA +1 (330) 686-2600

**Audio-Technica Limited**  
Old Lane, Leeds LS11 8AG England +44 (0) 113 277 1441

**Audio-Technica (Greater China) Limited**  
Unit K, 9/F., Kaiser Est. (Ph.2) 51 Man Yue St. Kowloon, HK. +852-2356-9268

**Audio-Technica (S.E.A.) Pte. Ltd.**  
No 1 Ubi View, #01-14 Focus One, Singapore 408555 +65-6749-5686

**Audio-Technica Corporation**  
2206, Naruse Machida, Tokyo Japan