

Concert Club V C Series

Loudspeaker



C115VA



C112VA



Club V C models fit to fly and ideal for installations

- Solid, reliable connection hardware for suspended installation
- Painsstaking selection of parts and components, optimized wooden enclosures, and a thorough reevaluation of speaker capacity take sonic performance to a new level.
- Protection circuit prevents excessive tweeter input due to acoustic feedback or other causes.
- Durable enclosure with foamed steel grilles, and large metal handles for improved handling
- The YSProcessing (Yamaha Speaker Processing) switch provided on the EMX series powered mixers and P series amplifiers enhances matching for even greater sonic impact.

OPTIONS (C112VA ONLY)

BCS251
Ceiling Bracket

BBS251
Baton Bracket

BWS251-300/400
Wall Bracket

Concert Club V C Series

GENERAL SPECIFICATIONS

Model	C115VA		C112VA
Type	2-way bass-reflex		
Frequency range (-10dB)	55Hz-16kHz		60Hz-16kHz
Nominal coverage (Horizontal x Vertical)	90° x 40°		
Nominal impedance	8Ω		
Power rating	NOISE	250W	175W
	PGM	500W	350W
	MAX	1000W	700W
Sensitivity (1W,1m)	99dB SPL		97dB SPL
Component	LF	15" cone	
	HF	CD horn + 2" voice coil compression driver	
Connectors	Barrier strip		
Dimensions (W x H x D)	485 x 707 x 373mm (19.1" x 27.8" x 14.7")		416 x 620 x 329mm (16.4" x 24.4" x 13.0")
Weight	29.9kg (65.9lbs)		21.8kg (48.1lbs)
Accessories	3/8" Eyebolt x4		3/8" Eyebolt x4, W5/16" screw x4 for 251 series brackets

DIMENSIONS

unit : mm (inch)

C115VA

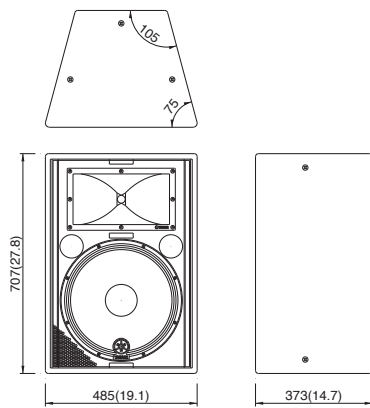

C112VA

