

KMT12

High tech multi-task powered 12" subwoofer with DSP and power output

Redline

DATASHEET

array
K

Features

- Unique performance-to-size ratio
- Fitted with integral handles and castors
- Direct radiating, long excursion 12" driver
- Ultra fast set-up and dismantling system
- Analog and digital AES-EBU inputs
- RS485 and USB connectivity for remote control

Applications

- Theatrical sound reinforcement
- Concert halls, clubs, houses of worship
- Portable and installed audio-visual systems
- Cinema and special effects
- Optimized for KK52, KK102 or KMT12P

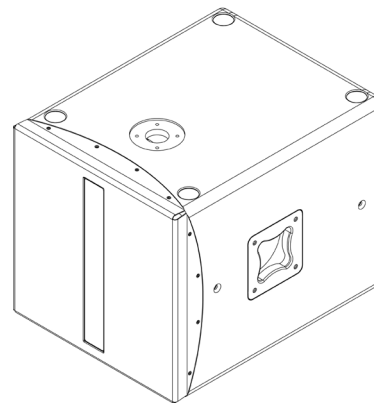

The K-array KMT18 is a full-featured audio systems featuring a powered 18" subwoofer, programmable on-board DSP and multiple analog and digital inputs and outputs for creating a wide array of speaker configurations. The amplifier mounted on board is class D, delivering 2 x 1000 W at 8Ω.

The KMT18 features an integrated touch screen, providing intuitive control over the main DSP functions: input/output levels, signal routing, offset delays for subwoofer and speakon output (up to 12 ms., each) and overall system delay (up to 330 ms.).

All DSP functions, including EQ, can also be remote controlled via software over USB or RS485 (3-pin XLR).

The KMT series provides two balanced analog line level inputs and a two-channel AES/EBU digital input. An integrated class D amplifier delivers 2 x 1000 W at 8Ω, with a max THD of 1% (EIAJ test @ 1KHz). The KMT18 features multiple analog and digital outputs, including a Speakon output to connect a wide array of passive

speakers including mid-high modules (KK52, KK102) or additional passive subwoofers (KMT18P). To optimize performance, the on-board DSP includes up to 40 programmable presets. The first 8 have been designed by K-array, the additional 32 slots can be used to create, save, and store personal presets using the K-framework software.

The KMT series' unique four-corner port configuration provides symmetrical back loading to the speakers, for extended bass response with very low distortion. The port configuration also provides incredible structural strength to the cabinet, despite its light weight. Pocket handles and an M20 thread mount position for attaching mid-high speakers makes the Redline series convenient to use and ideal for medium throw applications in theaters, concert halls, and Audio/Video installations.

All KMT components are designed by K-array and custom-made under K-array's quality control system.

KMT12

Acoustics

Speaker Power handling	700 W ^(AES)
Max power	1200 W ¹
Impedance	8Ω
Frequency range	40Hz - 150 Hz +/- 3dB (preset dependent)
SPL 1W / 1mt	99 dB ²
Maximum SPL	128 dB continuous - 134 dB peak

Coverage

Omni

Crossover

Type	DSP controlled
Frequency	150 Hz (preset dependent)

Transducers

Full range	1 x 12" Neodymium speakers with 3" voice coil
------------	---

Audio Input

Analog Connectors	2 male + 2 female 3-pin balanced XLR
Digital Connectors	1 male + 1 female 3-pin XLR

Audio powered Output

Connector	Female Speakon
Wiring	Pin1+= CH1+ Pin1= CH1- Pin2+= N.C. Pin2= N.C.

Remote control Input

Connectors	1 male + 1 female XLR parallel / 1 USB B Jack serial converter
------------	--

Power Input

Connectors	2 x PowerCon IN/OUT
------------	---------------------

Amplifiers

Type	1 modules class D - DSP controlled
Subwoofer power	1000 Watt ³ @8Ω
Speaker power output	1000 Watt ³ @8Ω
Speaker power output	Dynamic limiter, over current, over temp, short circuits

AC power

Operating range	85 - 130 Vac 60Hz / 190 - 240 Vac 50Hz (Auto Switch)
I. nom	5.5 A / 115 Vac - 2.9 A / 230 Vac
Minimum operation voltage	85 Vac - 190 Vac
Maximum operation voltage	130 Vac - 240 Vac
Max continuous and burst current	6A(>10 sec) - 12A (<1 sec) @ 130 Vac - 240 Vac 10A(>10 sec) - 20A (<1sec) @ 85 Vac - 190 Vac

Physical

Dimensions	32.5 x 33.5 x 43.5 cm (12.91" x 13.19" x 17.13")
Weight	15.6 Kg (34.39 lbs)

Notes for data

1. Maximum RMS applicable power for a musical signal, the reference signal is the one proposed by EIAJ standard.

2. Measured @4 mt then scaled @1 mt

3. Amplifier wattage rating is based on the maximum unclipped burst sine wave RMS voltage that the amplifier will produce into the nominal load impedance.

New materials and design are introduced into existing products without previous notice. Present systems may differ in some respects from those presented in this brochure.