

9232

Analog Utility Distribution Amplifier

Owner's Manual



9232-OM
Version: 1.1



9232 • Analog Utility Distribution Amplifier Owner's Manual

- Cobalt Part Number: **9232-OM**
- Document Issue: **1.1**
- Printed in the United States.
- Last Author: CGG
- Printing Date: 8/8/2012

The information contained in this Owner's Manual is subject to change without notice or obligation.

Copyright



© 2012 Cobalt Digital Inc. All rights reserved.

Contents of this publication may not be reproduced in any form without the written permission Cobalt Digital Inc. Reproduction or reverse engineering of copyrighted software is prohibited.

Notice

The material in this manual is furnished for informational use only. It is subject to change without notice and should not be construed as a commitment by Cobalt Digital Inc. Cobalt Digital Inc. assumes no responsibility or liability for errors or inaccuracies that may appear in this manual.

Trademarks

-  is a registered trademark of Ross Video Limited.
-  is a registered trademark of Cobalt Digital Inc.
- All other product names and any registered and unregistered trademarks mentioned in this manual are used for identification purposes only and remain the exclusive property of their respective owners.

Important Regulatory and Safety Notices

Before using this product and any associated equipment, refer to the “Important Safety Instructions” listed below so as to avoid personnel injury and to prevent product damage.

Products may require specific equipment, and /or installation procedures be carried out to satisfy certain regulatory compliance requirements. Notices have been included in this publication to call attention to these Specific requirements.

Symbol Meanings



This symbol on the equipment refers you to important operating and maintenance (servicing) instructions within the Product Manual Documentation. Failure to heed this information may present a major risk of damage or injury to persons or equipment.



Warning

The symbol with the word “**Warning**” within the equipment manual indicates a potentially hazardous situation, which if not avoided, could result in death or serious injury.



Caution

The symbol with the word “**Caution**” within the equipment manual indicates a potentially hazardous situation, which if not avoided, may result in minor or moderate injury. It may also be used to alert against unsafe practices.



Notice

The symbol with the word “**Notice**” within the equipment manual indicates a situation, which if not avoided, may result in major or minor equipment damage or a situation which could place the equipment in a non-compliant operating state.



**ESD
Susceptibility**

This symbol is used to alert the user that an electrical or electronic device or assembly is susceptible to damage from an ESD event.

Important Safety Instructions



Caution

This product is intended to be a component product of the openGear[®] 8300 series (or equivalent) frame. Refer to the frame Owner’s Manual for important safety instructions regarding the proper installation and safe operation of the frame as well as it’s component products.



Warning

Certain parts of this equipment namely the power supply area still present a safety hazard, with the power switch in the OFF position. To avoid electrical shock, disconnect all A/C power cords from the chassis' rear appliance connectors before servicing this area.



Warning

Service barriers within this product are intended to protect the operator and service personnel from hazardous voltages. For continued safety, replace all barriers after any servicing.

This product contains safety critical parts, which if incorrectly replaced may present a risk of fire or electrical shock. Components contained within the product’s power supplies and power supply area, are not intended to be customer serviced and should be returned to the factory for repair.

To reduce the risk of fire, replacement fuses must be the same type and rating.

Only use attachments/accessories specified by the manufacturer.

EMC Notices

US FCC Part 15

This equipment has been tested and found to comply with the limits for a class A Digital device, pursuant to part 15 of the FCC Rules. These limits are designed to provide reasonable protection against harmful interference when the equipment is operated in a commercial environment. This equipment generates, uses, and can radiate radio frequency energy and, if not installed and used in accordance with the instruction manual, may cause harmful interference to radio communications. Operation of this equipment in a residential area is likely to cause harmful interference in which case users will be required to correct the interference at their own expense.



Notice

Changes or modifications to this equipment not expressly approved by Cobalt Digital could void the user's authority to operate this equipment.

CANADA

This Class "A" digital apparatus complies with Canadian ICES-003.

Cet appareil numérique de classe "A" est conforme à la norme NMB-003 du Canada.

EUROPE

This equipment is in compliance with the essential requirements and other relevant provisions of **CE Directive 93/68/EEC**.

INTERNATIONAL

This equipment has been tested to **CISPR 22:1997** along with amendments **A1:2000** and **A2:2002** and found to comply with the limits for a Class A Digital device.



Notice

This is a Class A product. In domestic environments this product may cause radio interference in which case the user may have to take adequate measures.

Maintenance/User Serviceable Parts

Routine maintenance to this product is not required. This product contains no user serviceable parts. If the module does not appear to be working properly, please contact Technical Support using the numbers listed under the "Contact Us" section on the last page of this manual. Refer to the "Warranty and Repair Policy" section in this manual for details.

Environmental Information

The equipment that you purchased required the extraction and use of natural resources for its production. It may contain hazardous substances that could impact health and the environment.

To avoid the potential release of those substances into the environment and to diminish the need for the extraction of natural resources, Cobalt Digital encourages you to use the appropriate take-back systems. These systems will reuse or recycle most of the materials from your end-of-life equipment in an environmentally friendly and health conscious manner.

The crossed-out wheeled bin symbol invites you to use these systems.

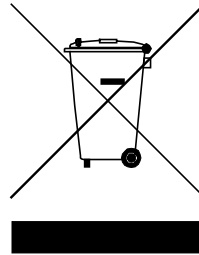

If you need more information on the collection, reuse, and recycling systems, please contact your local or regional waste administration.

You can also contact Cobalt Digital for more information on the environmental performances of our products.

openGear Contents

Introduction	1-7
A Word of Thanks	1-7
Overview	1-7
Functional Block Diagrams	1-7
Features.....	1-9
Documentation Terms.....	1-9
Installation and Setup	2-10
Static Discharge	2-10
Unpacking.....	2-10
Rear Module Installation (Optional).....	2-11
Board Installation	2-12
BNC Labels	2-12
Cable Connections	2-12
User Controls	3-14
Jumper Locations.....	3-15
LEDs.....	3-15
Button Controls.....	3-16
Control and Monitoring	4-17
DashBoard Control System.....	4-17
SNMP Monitoring and Control	4-19
Specifications	5-20
Service Information	6-22
Troubleshooting Checklist.....	6-22
Power LED Conditions.....	6-23
Bootload Button.....	6-23
Warranty and Repair Policy	Error! Bookmark not defined.-Error! Bookmark not defined.
Ordering Information	7-26
9232 and Related Products.....	7-26
Contact Us	7-27
Contact Cobalt Digital Inc.	7-27
Visit us at the Cobalt Digital Inc. website.....	7-27

Introduction

In This Chapter

This chapter contains the following sections:

- A Word of Thanks
- Overview
- Functional Block Diagrams
- Features
- Documentation Terms

A Word of Thanks

Congratulations on choosing the **9232 Analog Utility Distribution Amplifier**. The 9232 is part of a full line of modular conversion gear for broadcast TV environments. The Cobalt Digital openGear[®] line includes video decoders and encoders, audio embedders and de-embedders, distribution amplifiers, format converters, and much more. Cobalt openGear[®] modular conversion gear will meet your signal conversion needs now and well into the future.

Should you have questions pertaining to the installation or operation of your 9232, please contact us at the numbers listed on the back cover of this manual. We are happy to help with any questions regarding this or any other Cobalt card.

Overview

The 9232 is an analog general-purpose distribution amplifier. It is very useful in digital systems when there is a requirement for the distribution of a few analog signals, such as a color black reference.

The 9232 is a general-purpose amplifier for use in the distribution of analog SD-video, Tri-level sync or AES3id audio. It is intended for use in situations where cable equalization and differential input are not needed, and clamping is not required. Gain is adjustable over a wide range of $\pm 3\text{dB}$.

This amplifier is DC-coupled and will faithfully provide all aspects of a video input signal to eight identical output copies with very low distortion. The use of new generation integrated circuits and innovative engineering has resulted in excellent performance combined with economy.

The 9232 is designed for use in the openGear[®] 8300 series frames (or equivalent 20-slot frame).

Functional Block Diagrams

This section includes functional block diagrams to illustrate the 9232 functions including the looping feature.

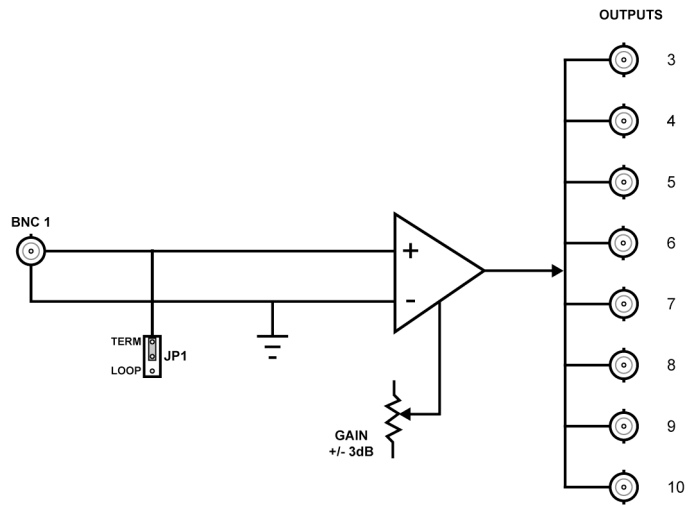

Figure 1. Simplified Block Diagram of 9232 Functions

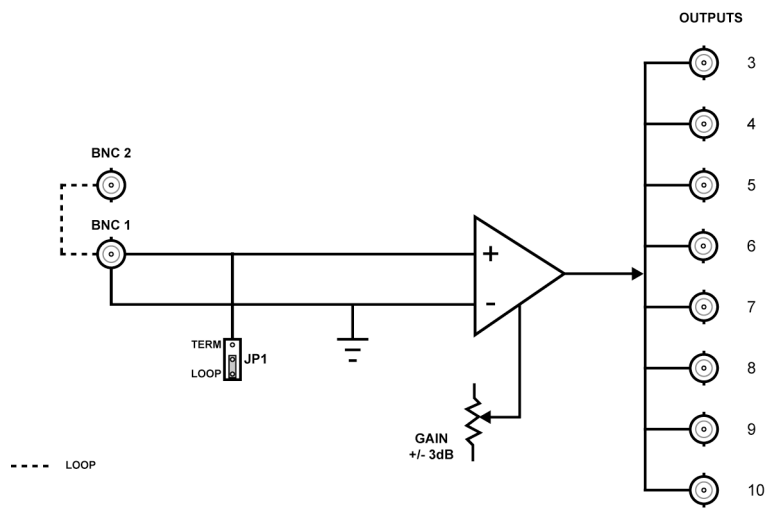

Figure 2. Simplified Block Diagram of 9232 with Looping Function

Features

The following features make the 9232 the best solution for general analog distribution:

- 8 analog video outputs
- DC Coupled
- Wide adjustable gain range of $\pm 3\text{dB}$
- Low distortion
- Excellent isolation between outputs
- Power to each card is individually fused
- Fits **8320** (or equivalent 20-slot) frames
- Fully compliant with openGear[®] specifications
- 5-year transferable warranty

Documentation Terms

The following terms are used throughout this guide:

- **“Frame”** refers to the 8320 frame that houses the 9232 card, as well as any openGear[®] frames.
- All references to the **8320 (or equivalent 20-slot) frame** includes versions of the 20-slot frame.
- **“Operator”** and **“User”** both refer to the person who uses the 9232.
- **“Board”** and **“Card”** both refer to the 9232 unit itself, including all components and switches.
- **“System”** and **“Video system”** both refer to the mix of interconnected production and terminal equipment in which the 9232 operates.

Installation and Setup

In This Chapter

This chapter contains the following sections:

- Static Discharge
- Unpacking
- Rear Module Installation (Optional)
- Board Installation
- BNC Labels
- Cable Connections

Static Discharge

Whenever handling the 9232 and other related equipment, please observe all static discharge precautions as described in the following note:



**ESD
Susceptibility**

Static discharge can cause serious damage to sensitive semiconductor devices. Avoid handling circuit boards in high static environments such as carpeted areas, and when wearing synthetic fiber clothing. Always exercise proper grounding precautions when working on circuit boards and related equipment.

Unpacking

Unpack each 9232 you received from the shipping container, and check the contents against the packing list to ensure that all items are included. If any items are missing or damaged, contact your sales representative or Cobalt Digital directly.

Rear Module Installation (Optional)

The 9232 is compatible with the **8320 (or equivalent 20-slot)** series frames. The procedure for installing the Rear Module in your frame is the same regardless of the frame or module used. However, a different module is required depending on the frame you are using.

Installing the Rear Module

If you received a Rear Module with your 9232, you will need to install the module in your frame before you can install the 9232 in the frame, or connect cables to the slot you have chosen for the 9232. Skip this section if you are installing the 9232 in a frame where the Rear Module is already installed.

Use the following procedure to install the Rear Module in a frame:

1. Refer to the frame Owner's Manual, to ensure that the frame is properly installed according to instructions.
2. On the rear of the frame, locate the card frame slot.
3. Remove the Blank Plate from the rear of the slot you have chosen for the 9232 installation. If there is no Blank Plate installed, proceed to the next step.
4. As shown in **Figure 3**, seat the bottom of the rear module in the seating slot at the base of the frame's back plane.

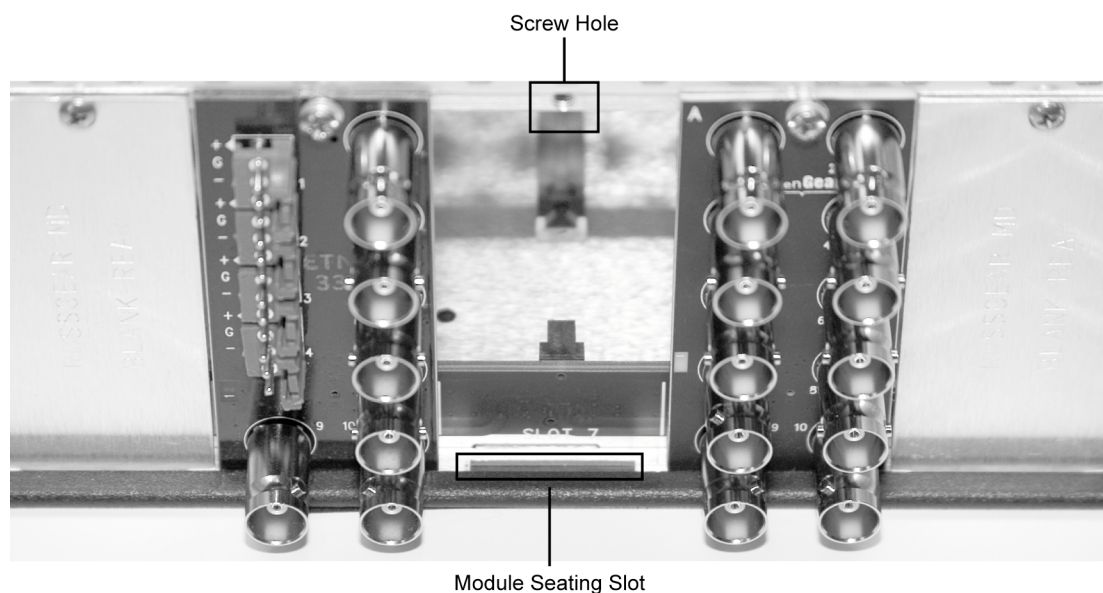

Figure 3. Rear Module Installation

5. Align the top hole of the rear module with the screw hole on the top edge of the frame back plane.
6. Using a Phillips driver and the supplied screw, fasten the rear module to the back plane. Do not over tighten.
7. Ensure proper frame cooling and ventilation by having all rear frame slots covered with Rear Module or blank metal plates. If you need blanks, refer to the chapter, “**Ordering Information**” in your frame Owner’s Manual, and contact your Cobalt Digital sales representative.

This completes the procedure for installing the Rear Module in a 8300 series frame.

Board Installation

Use the following procedure to install the 9232 in a frame:

1. Refer to the Owner’s Manual of your frame to ensure that the frame is properly installed.
2. After selecting the desired frame installation slot, hold the 9232 card by the edges and carefully align the card edges with the slots in the frame.
3. Fully insert the card into the frame until the rear connection plugs are properly seated on the midplane and rear modules.

This completes the procedure for installing the 9232 in a frame.

BNC Labels

Affix the supplied BNC label, as per the included instructions, to the BNC area on the rear of the rack frame.

Cable Connections

This section provides instructions for connecting cables to the installed Rear Modules on your frame backplane.

Connections for the Rear Modules Frames

The input of the 9232 can be terminated on the card depending on the rear module used. It is not necessary to terminate unused outputs.

The 9232 may be used with the following Rear Modules:

- **RM20-9232-B** Standard-Width (Full) Rear Module and **RM20-9232-B/S** Split Rear Module — Each card provides eight outputs and one looping output. If the input is looped on the rear module to another device, **JP1** must be set to **LOOP**. If looping is not used, either set **JP1** to **TERM**, or terminate the input externally at BNC 2.
- **RM20-9232-A/S** Split Rear Module — Each card provides four outputs. If the input is looped on the rear module to another device, **JP1** must be set to **LOOP**. If looping is not used, either set **JP1** to **TERM**, or terminate the input externally at BNC 2.

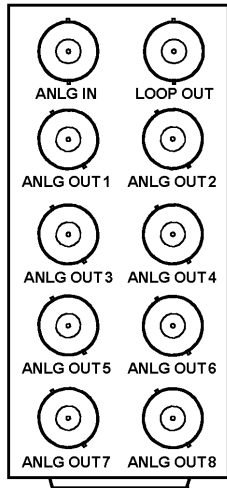

Figure 4. Cable Connections for the RM20-9232-B Rear Module

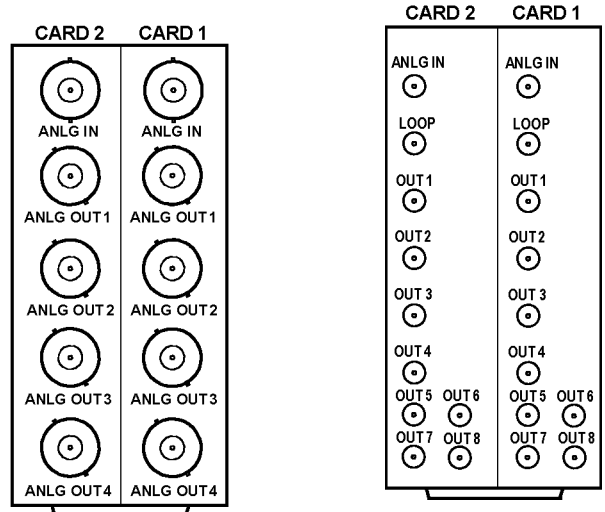

Figure 5. Cable Connections for the RM20-9232-A/S and RM20-9232-B/S Split Rear Modules

User Controls

In This Chapter

This chapter includes the following sections:

- Jumper Locations
- LEDs
- Button Controls

Jumper Locations

The following sections describe the jumpers on the 9232.

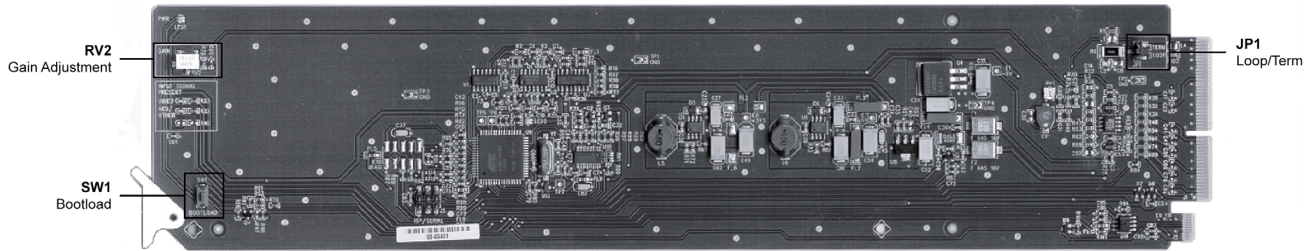

Figure 6. Jumper Locations

JP1 — Local Termination Jumper

The position of **JP2** selects an optional 75ohm termination on the input of the 9232 card.

Select one of the following options:

- **TERM** — Install the jumper in this position to terminate the input signal on this card. This is the default setting.
- **LOOP** — Install the jumper in this position to leave the input unterminated. For example, configure this setting if you wish to loop the signal to another device.

RV2 — Gain Adjustment

The rotation of **RV2** adjusts the Gain level of the 9232 and provides a gain range of +/- 3dB.

LEDs

The following sections describe the 9232 LEDs. Refer to **Figure 8** for LED locations.

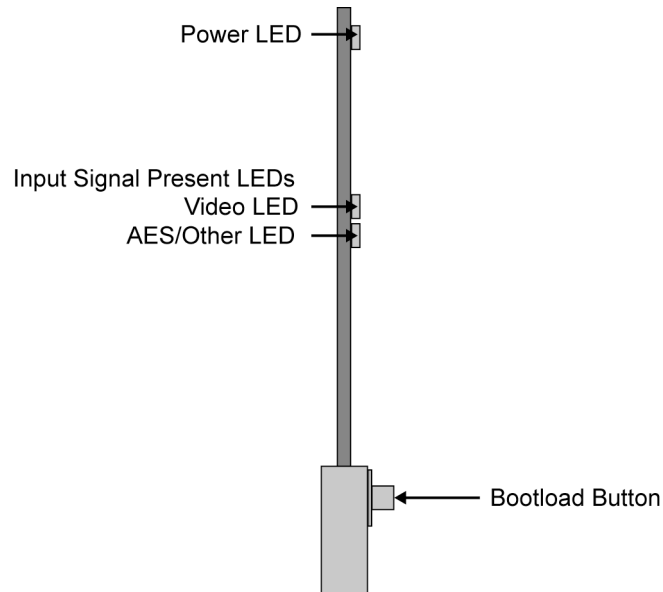

Figure 7. LED Locations

PWR (Power) LED

The **PWR** LED indicates the overall operating status of the 9232. This LED displays the following conditions:

- **Green** — The card is operating normally.
- **Flashing Green** — The card requires a software upgrade.
- **Red** — The card is not operational. Refer to the chapter, “**Service Information**” for details on this condition.

Input Signal Present LEDs

The **Input Signal Present** LEDs indicates the status of the analog input. This group of LEDs display the following conditions:

- **VIDEO** — If the **VIDEO** LED is lit, a valid analog video input signal is present on BNC 1.
- **AES/OTHER** — If the **AES/OTHER** LED is lit, a valid AES signal, or some other analog signal, is present on the input. The signal must be greater than 0.5Vp-p.

Note

Slowly changing, or small, amplitude signals will pass through the card, but the LEDs may be unlit. In this case, it is recommended to disable **the Notify on Input Loss** option via DashBoard. Note that the Input Signal Present threshold is set to assume a level of 1Vp-p.

Button Controls

The following sections describe the 9232 buttons. Refer to **Figure 8** for button location.

SW1 — Bootload Button

This button is used for factory service in the unlikely event of a complete card failure. The Bootload process is further described in the chapter, “**Service Information**”, of this manual.

Control and Monitoring

In This Chapter

This section provides a detailed explanation on using remote control functions with your 9232.

The following topics are discussed:

- DashBoard Control System
- SNMP Monitoring and Control

DashBoard Control System

The DashBoard Control System™ enables you to monitor and control openGear® frames and controller cards from a computer. DashBoard communicates with other cards in the frame through the MFC-8320-N Network controller card. This card is required in order to use DashBoard to configure the 9232.

The DashBoard software and manual can be downloaded from the Cobalt Digital website.

Using the Menus

You must first install the DashBoard Control System on your computer. Refer to the *DashBoard Owner's Manual* for software installation procedures and using the DashBoard interface.

The following tables and sections describe the menus, items, and parameters available from the DashBoard Control System for the 9232.

Status Menus

The following table summarizes the **Status Menu** options available in DashBoard.

Table 1. Status Menus

Menu	Item	Parameters	Description	
Product (Read-only)	Product	9232		
	Supplier	Cobalt Digital Inc.		
	Board Rev	##		
	Serial Number	#####-###		
	Software Rev	###		
Hardware (Read-only)	Voltage (mV)	#	Supply Voltage	
	Current (mA)	#	Current consumption of card	
	Rear Module	#	Rear module for the card	
	CPU Headroom	#	Processing power available	
	RAM Available (bytes)	#	On-board processing memory available	
	EE Bank	#	Storage count	
Signal (Read-only)	Signal Status	Green – Video Present	Card is passing valid analog video	
		Green – AES/Other	Card is passing AES audio or other analog signal	
		Green – No input	No input present or the signal is below the detection threshold. The Notify on Loss of Input option is disabled.	
		Red – No input	No input present or the signal is below 0.5V p-p. The Notify on Loss of Input option is enabled.	
	Signal Format	480i 59.94 720p 59.94 1080i 59.94 1080p 29.97 576i 50 720p 50 1080i 50 1080p 25		Indicates the valid video format detected
		Unknown Video		Indicates a video signal is present but is an unknown format
		AES/Other		Indicates an audio or other analog signal is detected

Configuration Menus

The following table summarizes the **Configuration Menu** options available in DashBoard.

Table 2. Configuration Menus

Menu	Item	Parameters	Description
Setup	Notify on Loss of Input	Checkbox is selected*	DashBoard reports the loss of input
		Checkbox is unselected	DashBoard does not report the loss of input

* This is the default setting.

SNMP Monitoring and Control

The MFC-8320-N Network Controller card in the frame provides optional support for remote monitoring and control of your frame and 9232 using Simple Network Management Protocol (SNMP), which is compatible with many third-party monitoring and control tools.

Refer to your 9232 Management Information Base (MIB) file for a breakdown of SNMP controls on this card.

Refer to your frame Owner's Manual for additional information on SNMP Monitoring and Control.

Specifications

In This Chapter

This chapter includes the Technical Specifications for the 9232.

Table 3. 9232 — Technical Specifications

Category	Parameter	Specification
Analog Input	Number of Inputs	1 (Looping*)
	Input Impedance	75Ω terminating
	Return Loss	43dB to 5MHz, 35dB to 20MHz
	Nominal Signal Level	1Vpp (video, AES-3id)
Analog Outputs	Number Of Outputs	8
	Output Impedance	75Ω
	Output Return Loss	45dB to 5MHz, 41dB to 20MHz
	Output Isolation	51dB to 5MHz, 40dB to 20MHz
	DC Offset	<30mV
	Frequency Response	±0.08dB to 10MHz, ±0.2dB to 20MHz
	Differential Phase	<0.1° in NTSC, <0.3° in PAL
	Differential Gain	<0.1% in NTSC, <0.1% in PAL
	RMS Noise (unweighted)	68dB
Performance (all outputs loaded)	Gain Range	±3dB
	Gain Stability	<0.2% per 10°C
	Delay	7ns (9° @ 3.58MHz) NTSC 7ns (11° @ 4.43MHz) PAL
	Chrominance-to-Luminance Delay	<2.0ns
	Line Rate Window Tilt	<0.1%
	Field Rate Window Tile	<0.1%
	Bandwidth	-3dB @ 56MHz Typical
Power	Total Power Draw	<1.5W

*Looping only available with the RM-9232-B Rear Module.

Specifications are subject to change without notice

Service Information

In This Chapter

This chapter contains the following sections:

- Troubleshooting Checklist
- Power LED Conditions
- Bootload Button
- Warranty and Repair Policy

Troubleshooting Checklist

Routine maintenance to this product is not required. In the event of problems with your 9232, the following basic troubleshooting checklist may help identify the source of the problem. If the card still does not appear to be working properly after checking all possible causes, please contact your products distributor, or the Technical Support department at the numbers listed under the “**Contact Us**” section at the end of this manual.

1. **Visual Review** — Performing a quick visual check may reveal many problems, such as connectors not properly seated or loose cables. Check the card, the frame, and any associated peripheral equipment for signs of trouble.
2. **Power Check** — Check the power indicator LED on the distribution frame front panel for the presence of power. If the power LED is not illuminated, verify that the power cable is connected to a power source and that power is available at the power main. Confirm that the power supplies are fully seated in their slots. If the power LED is still not illuminated, replace the power supply with one that is verified to work.
3. **Reset the Card in the Frame** — Eject the card and re-insert it in the frame.
4. **Check Control Settings** — Refer to the Installation and Operation sections of the manual and verify all user-adjustable component settings.
5. **Input Signal Status** — Verify that source equipment is operating correctly and that a valid signal is being supplied.
6. **Output Signal Path** — Verify that destination equipment is operating correctly and receiving a valid signal.
7. **Card Exchange** — Exchanging a suspect card with a card that is known to be working correctly is an efficient method for localizing problems to individual cards.

Power LED Conditions

The top front edge of the module has a Power LED which indicates card status. The Power LED displays the following conditions:

- **Off** — no power to the card.
- **Amber** — the card is running internal diagnostics while powering up.
- **Green** — normal operation.
- **Flashing Green** — the card is waiting for a software upgrade.
- **Red** — solid or flashing means the card is not operational. Reseat card in frame, check the Rear Module type and connections, or call Cobalt Digital Technical Support.

Bootload Button

In the unlikely event of a complete card failure, you may be instructed by a Cobalt Digital Technical Support specialist to perform a complete software reload on the 9232. Contact Cobalt Digital Technical Support for the latest software load for your card.

Use the following procedure to perform a complete software reload on the card:

1. Eject the card.
2. Press and hold the **Bootload** button, while re-inserting the card into the frame.
3. Release the button.

The **PWR LED** will flash GREEN while the card is waiting for a new software load.

If a new software load is not sent to the card within 60 seconds, the card will attempt to restart with its last operational software load.

This completes the procedure for performing a complete software reload on the card.

Warranty and Repair Policy

This product is warranted to be free from defects in material and workmanship for a period of five (5) years from the date of shipment to the original purchaser, except that 4000, 5000, 6000, 8000 series power supplies, and Dolby® modules (where applicable) are warranted to be free from defects in material and workmanship for a period of one (1) year.

Cobalt Digital Inc.'s ("Cobalt") sole obligation under this warranty shall be limited to, at its option, (i) the repair or (ii) replacement of the product, and the determination of whether a defect is covered under this limited warranty shall be made at the sole discretion of Cobalt.

This limited warranty applies only to the original end-purchaser of the product, and is not assignable or transferrable therefrom. This warranty is limited to defects in material and workmanship, and shall not apply to acts of God, accidents, or negligence on behalf of the purchaser, and shall be voided upon the misuse, abuse, alteration, or modification of the product. Only Cobalt authorized factory representatives are authorized to make repairs to the product, and any unauthorized attempt to repair this product shall immediately void the warranty. Please contact Cobalt Technical Support for more information.

To facilitate the resolution of warranty related issues, Cobalt recommends registering the product by completing and returning a product registration form. In the event of a warrantable defect, the purchaser shall notify Cobalt with a description of the problem, and Cobalt shall provide the purchaser with a Return Material Authorization ("RMA"). For return, defective products should be double boxed, and sufficiently protected, in the original packaging, or equivalent, and shipped to the Cobalt Factory Service Center, postage prepaid and insured for the purchase price. The purchaser should include the RMA number, description of the problem encountered, date purchased, name of dealer purchased from, and serial number with the shipment.

Cobalt Digital Inc. Factory Service Center

2406 E. University Avenue

Office: (217) 344-1243

Urbana, IL 61802 USA

Fax: (217) 344-1245

www.cobaltdigital.com

Email: info@cobaltdigital.com

THIS LIMITED WARRANTY IS EXPRESSLY IN LIEU OF ALL OTHER WARRANTIES EXPRESSED OR IMPLIED, INCLUDING THE WARRANTIES OF MERCHANTABILITY AND FITNESS FOR A PARTICULAR PURPOSE AND OF ALL OTHER OBLIGATIONS OR LIABILITIES ON COBALT'S PART. ANY SOFTWARE PROVIDED WITH, OR FOR USE WITH, THE PRODUCT IS PROVIDED "AS IS." THE BUYER OF THE PRODUCT ACKNOWLEDGES THAT NO OTHER REPRESENTATIONS WERE MADE OR RELIED UPON WITH RESPECT TO THE QUALITY AND FUNCTION OF THE GOODS HEREIN SOLD. COBALT PRODUCTS ARE NOT AUTHORIZED FOR USE IN LIFE SUPPORT APPLICATIONS.

COBALT'S LIABILITY, WHETHER IN CONTRACT, TORT, WARRANTY, OR OTHERWISE, IS LIMITED TO THE REPAIR OR REPLACEMENT, AT ITS OPTION, OF ANY DEFECTIVE PRODUCT, AND SHALL IN NO EVENT INCLUDE SPECIAL, INDIRECT, INCIDENTAL, OR CONSEQUENTIAL DAMAGES (INCLUDING LOST PROFITS), EVEN IF IT HAS BEEN ADVISED OF THE POSSIBILITY OF SUCH DAMAGES.

In Case of Problems

Should any problem arise with your 9232, please contact the Cobalt Digital Technical Support Department. (Contact information is supplied at the end of this publication.)

A Return Material Authorization number (RMA) will be issued to you, as well as specific shipping instructions, should you wish our factory to repair your 9232. If required, a temporary replacement module will be made available at a nominal charge. Any shipping costs incurred will be the responsibility of you, the customer. All products shipped to you from Cobalt Digital Inc. will be shipped collect.

The Cobalt Digital Technical Support Department will continue to provide advice on any product manufactured by Cobalt Digital Inc., beyond the warranty period without charge, for the life of the equipment.

Ordering Information

9232 and Related Products

Your **9232 Analog Utility Distribution Amplifier** is a part of the openGear® family of products. Cobalt Digital offers a full line of openGear® terminal equipment including distribution, conversion, monitoring, synchronizers, encoders, decoders, keyers, switchers, as well as analog audio and video products.

Standard Equipment

- **9232** Analog Utility Distribution Amplifier
- **9232-OM** Analog Utility Distribution Amplifier Owner's Manual

Optional Equipment

- **9232-OM** Analog Utility Distribution Amplifier Owner's Manual (additional)
- **RM20-9232-B** 20-slot Frame Rear I/O Module (Standard Width) 1 Video Input BNC, 1 Looped Video Output BNC, 8 Video Output BNCs
- **RM20-9232-A/S** 20-slot Frame Rear I/O Module (Split) 1 Video Input BNC, 4 Video Output BNCs
- **RM20-9232-B/S-HDBNC** 20-slot Frame Rear I/O Module (Split) 1 Video Input HDBNC, 1 Looped Video Output HDBNC, 8 Video Output HDBNCs per card
- **RM20-9232-B/S-DIN** 20-slot Frame Rear I/O Module (Split) 1 Video Input, 1 Looped Video Output, 8 Video Output per card (all connectors DIN 1.0/2.3)

Please contact your openGear® sales representative for a complete list of the available options.

Contact Us

Contact Cobalt Digital Inc.

PHONE	General Business Office and Technical Support	217.344.1243
	Fax	217.344.1245
E-MAIL	Tech Support	Support@cobaltdigital.com
	Sales Information	Sales@cobaltdigital.com
POSTAL SERVICE	Cobalt Digital Inc.	2406 East University Avenue Urbana, IL 61802 USA

Visit us at the Cobalt Digital Inc. website.

<http://www.cobaltdigital.com>

- Online catalog
- Related products and full product lines
- Trade show information
- Dealer information
- Cobalt Digital Inc. news