



NUAGE

Yamaha & Steinberg



CREATING 'KANDO' TOGETHER

YAMAHA CORPORATION
P.O. BOX1, Hamamatsu Japan
www.yamahaproaudio.com

*All specifications are subject to change without notice. *All trademarks and registered trademarks are property of their respective owners.



Printed in Japan

NUAGE

Yamaha & Steinberg

A New Platform for Unprecedented Post-production Productivity

Digital audio workstations, controllers, interfaces: professional post-production capabilities can only be realized when all components work together in perfect harmony. Nuage Integrated Audio Production System brings it all together in a collaboration that defines new standards of quality and workflow efficiency for virtually every aspect of the production process. Yamaha control and interface hardware seamlessly integrates with Steinberg Nuendo DAW software in a purpose-built system that offers unprecedented productivity and flexibility as well as premium audio quality.

Discerning engineers and artists who already depend on the sonic quality and intuitive workflow of Steinberg's native-processing Nuendo DAW will be pleased to learn that Nuendo 6, included with Nuage, takes that performance to a new level. And for maximum system versatility the dedicated Yamaha control surface and audio interface hardware is modular, so you can easily create a custom configuration that ideally matches your application.

Nuage for mixing, editing, dialog replacement in audio post production applications. Top-class hardware and software in perfect harmony at last.



Unparalleled Workflow Efficiency

A sleek user interface that combines time-tested elements with thoroughly researched and proven innovations, plus comprehensive visual feedback, give Nuage components intuitive, stress-free operability that significantly enhances productivity.

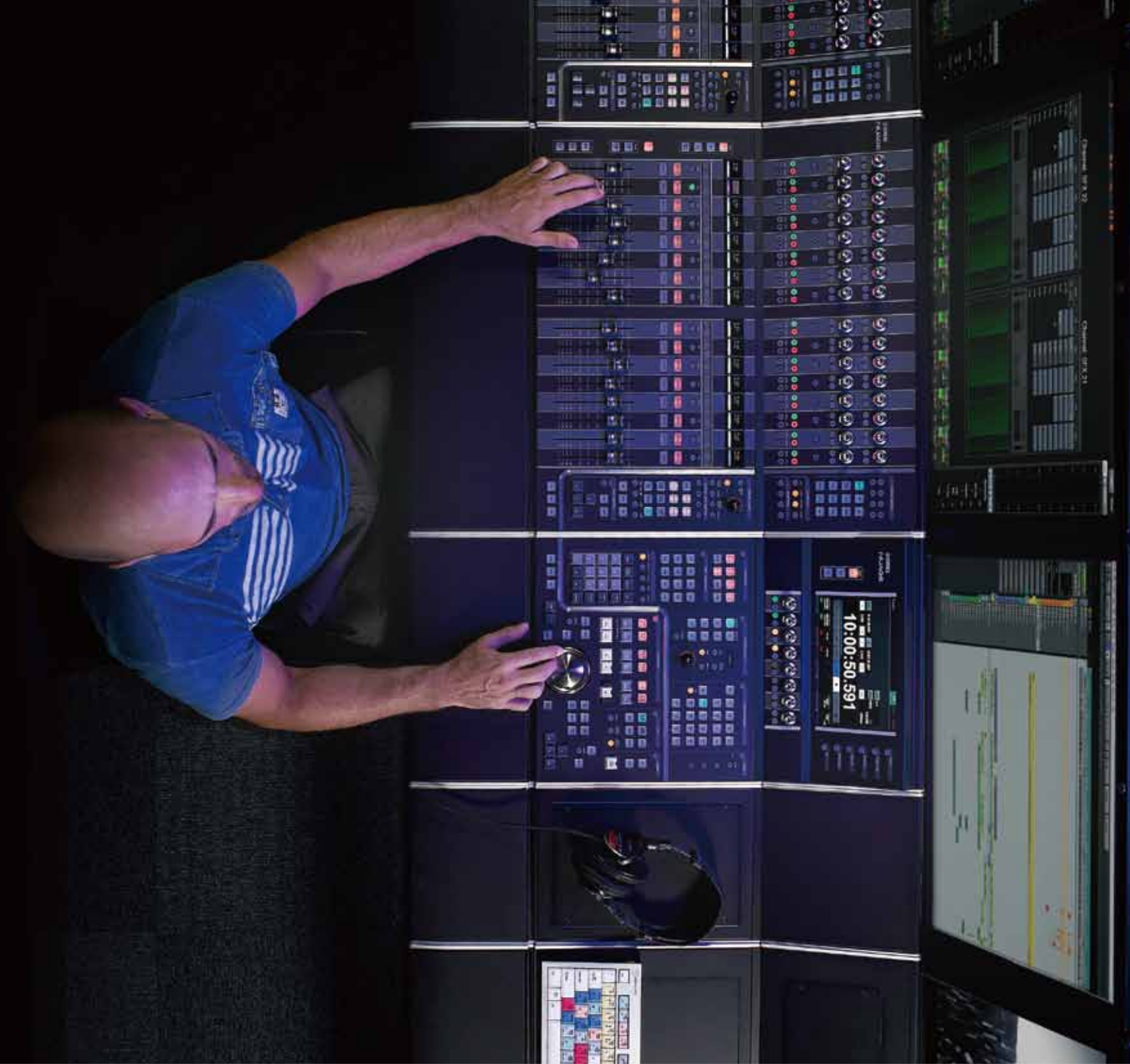

Extensive Console View



Innovative Navigation Features



Precision Jog Wheel



Dedicated and Customizable Controls

Superior Production Output Quality

To the client, the only thing that really matters is end product quality, and here's where Nuage really delivers. In addition to a low-stress working environment for engineers and re-recording mixers, Nuage offers advanced processing capabilities and sublime sonic quality that makes a marked difference in the final sound.

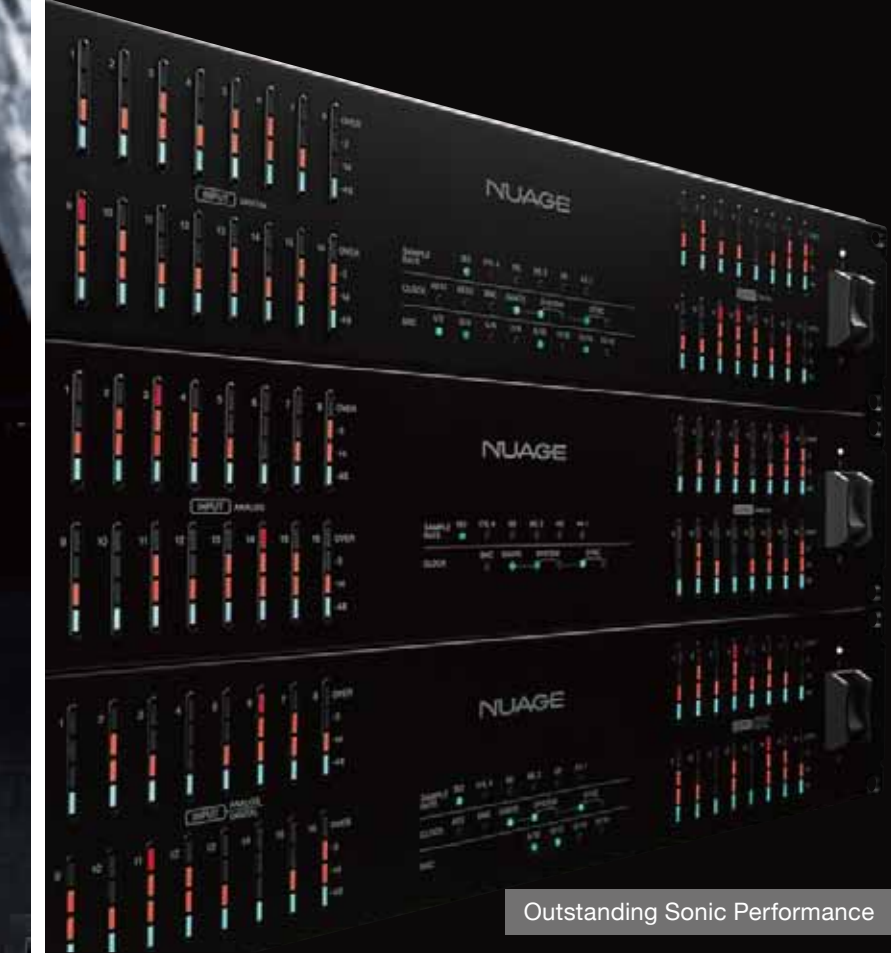

Outstanding Sonic Performance



Stress-free Monitoring



Complete DSP Surround processing



Sample-accurate Timecode Sync

Flexible Modular Architecture Plus Network Audio

With a modular architecture that lets you combine components you need to ideally support your application, plus network audio that allows you to lay out your system to match available infrastructure and installation requirements while maintaining undiminished audio transmission quality throughout, Nuage offers outstanding system flexibility and scalability.

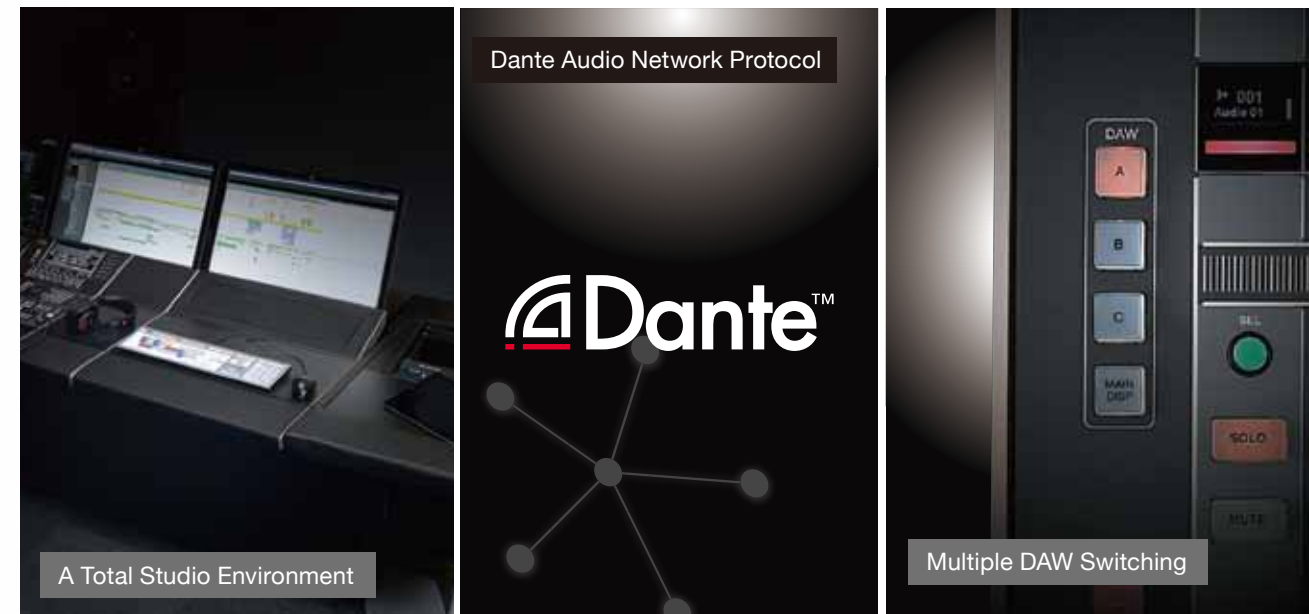

Modular Control Surfaces & High-performance Audio I/O





NUAGE

System Components

- NUAGE FADER
- NUAGE MASTER
- NUAGE WORKSPACE (LARGE)
- NUAGE WORKSPACE (SMALL)
- NUAGE I/O (16D)
- NUAGE I/O (16A)
- NUAGE I/O (8A8D)
- DANTE ACCELERATOR
- NUENDO 6
- NUENDO SYNCSTATION

Conceived and crafted for impeccable integration with Nuendo mixing functions.

NUAGE FADER

The most advanced, well-integrated channel strip control surface for any DAW. Nuage Fader works with a standard 24" LCD monitor to provide sweeping access to Nuendo mixing functionality, with deep integration and solid performance that can only be achieved in a purpose-built system. Yamaha console know-how meets Steinberg software excellence with beautiful results.



A Brilliant Fusion of Hardware & Software

Any standard 24" LCD monitor display* can be used to provide a smooth visual extension of the physical Nuage fader channel strips right into the Nuendo mixer window. The continuity between control surface and display achieved by the Extensive Console View concept keeps all controls and parameters in context so the operator can intuitively reach for the right fader, button, or knob while concentrating fully on the job at hand. 16 channels can be controlled at once with two encoders per channel, or all encoders can be mapped to one or two highlighted channels in the Channel Setting Mode.

* Monitor display(s) are not included and must be supplied by the user.



Multi-function Knobs

In addition to a linear fader, each of the 16 channel strips provided on each Nuage Fader unit includes two rotary encoders – “knobs” – that are touch sensitive and also include an integral push button. Each knob can control a number of parameters in a number of ways. Normally the knobs function within their own channel strip, allowing hands on control of 16 separate channels at a time. But in the Channel Setting Mode all 32 knobs are mapped to just one channel, allowing detailed control of multiple parameters for that channel, or the knobs can be assigned to two channels in 16-knob groups. All this versatility means the Nuage Fader unit will mesh effectively with just about any workflow, and even inspire new and improved ways of getting things done!



Touch Slider for Fast Channel Access

Now that everyone is thoroughly familiar with computer trackpads, the Nuage Touch Slider will be easy. Simply slide a finger along the horizontal Touch Slider strip to shift Nuendo channels left or right in relation to the Nuage Fader channel strips, use flick gestures to quickly shift a larger range of channels, or use the “Bank Flick” feature to flick channels in groups of eight. There are also customizable channel layouts that bring important channels to the surface with just one button press. Lock your stem or master busses to the surface to access them at any time.

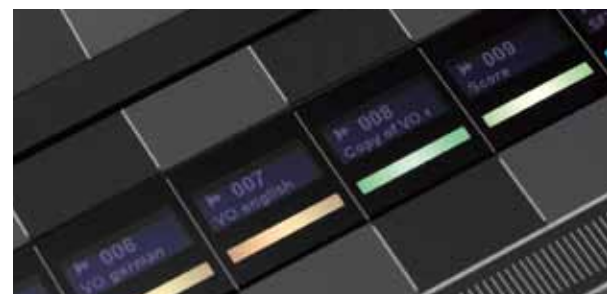

Color Matching with Nuendo Track Icons

Nuendo channel names appear in the corresponding Nuage Fader channel name displays, and the colors of the illuminated knob surrounds and the bars below the channel name displays match the colors of the Nuendo channel type icons, so the operator can confirm channel relationships at a glance.

Organized Utility Section

In addition to straightforward mixing and parameter tweaking, a powerful DAW like Nuendo allows a multitude of switching and selection operations that, if not comprehensively organized, can disrupt an otherwise smooth workflow. The Nuage Fader unit utility control section keeps everything neatly organized for easy, confusion-free access. CHANNEL VIEW controls switch between mixer channel displays, SECTION CONTROL controls allow convenient channel strip section switching, and DAW SELECT controls switch between multiple DAWs connected to the Nuage system.



Optimum Space Utilization

The compact, rack-mount compatible dimensions of Nuage components are an advantage to begin with, but thoughtful features like producer desk surfaces and a keyboard space built into the console palm rest take space utilization efficiency to the next level. Like many of the productivity features implemented in the Nuage system, the space-saving aspects are based on invaluable feedback from professionals in the field.

Ready for Large Multi-DAW Projects

A Nuage system can connect to up to three DAWs that can be brought online individually from the Nuage Fader DAW SELECT controls. The various DAWs can be located in separate studios or machine rooms where they are used to handle separate elements of a large project, and then brought together at the Nuage system for final assembly and editing. And since Nuage includes HUI control compatibility, it provides basic access to any HUI compatible DAW that you might want to use as a player or dubber.

Powerful post-production editing with a full selection of ergonomically arranged controls and touch-screen display.

NUAGE MASTER

Everything needed for fast, efficient Nuendo editing is available and within easy reach. The control selection and layout have been largely influenced by feedback from the field, giving operators what they really need where they need it, rather than a confusing tangle of superfluous bells and whistles. The interface is direct, intuitive, and businesslike, ready to get the job done with superlative productivity and quality.



Multifunction Touch-screen Display and Knobs

A responsive touch-screen display plus eight touch-sensitive multi-function knobs give you direct control of EQ, dynamics, plug-in effects, and other parameters with immediate, lucid visual feedback that contributes to smooth operation. When used with one or more Nuage Fader units the display also shows selected fader unit parameters, and the multi-function knobs work in the same way as those on the fader units for consistent operation throughout any combination of components.

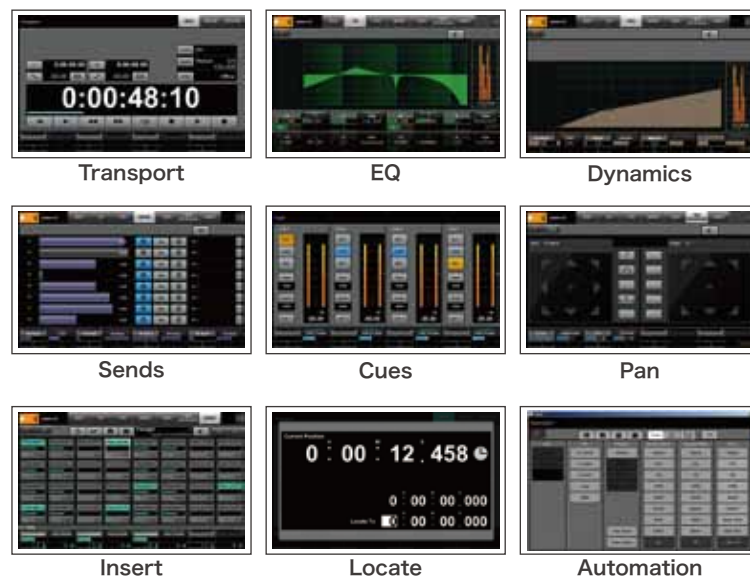

Precision Machined Jog Wheel

Precision machined from solid high-quality stainless steel stock, this jog wheel contributes to effortless editing and transport control with weight, inertia, and comfort that can make even marathon editing sessions a pleasure. Resolution is notably higher than the average editing jog wheel too, for unmatched accuracy in controlling forward and reverse playback at up to 8x speed, scrubbing, object and range selection, zoom, fades, and more.



User Assignable Section

Every engineer has his or her own way of approaching the editing process, and every application presents different challenges. The Nuage Master unit features a "User Assignable Section" with controls that can be customized by the operator to provide direct access to the functions and parameters needed for the task at hand. Functions that need to be performed repeatedly, such as importing audio files, for example, can be assigned for one-button efficiency.

Comprehensive, Easy-access Control Layout

The TRANSPORT section controls are central to most editing processes, so they're strategically located just above the jog wheel where the operator can easily manipulate both with minimum hand movement. The CONTROL ROOM section, providing direct access to Nuendo Control Room monitoring features, as well as the MONITOR SOURCE and CUE sections, are also located within easy reach above the transport controls, thoughtfully organized and grouped for fast, efficient, error-free operation.



Combine With Up To Three Nuage Fader Units

For applications that are all editing and little or no mixing, a Nuage Master unit and appropriate I/O might be all that is required. But when multiple sources/channels and mixing are part of the process, one Nuage Master unit can be used with from one to three Nuage Fader units, depending on the number of physical fader channels required.

Workspace units for a streamlined and productive working environment.

NUAGE WORKSPACE

Nuage Workspace units feature dimensions and design that are a perfect match for the Nuage Fader and Nuage Master units, allowing a keyboard, surround panner, 19 inch rack mount devices, and other custom extras to be added to a Nuage system while maintaining overall workflow and visual unity. Two Nuage Workspace units are available: a large model that is the same size as the Nuage fader unit, and a small model that can be added to a Nuage Master unit to match the width of a standard 24" monitor display.



* The photo shows a custom installation.

Three high-performance audio I/O units deliver exceptional sonic precision and quality.

NUAGE I/O

Designed with meticulous attention to details that make a real difference in the final sound, from parts selection to circuit layout, Nuage I/O audio interface units bring out the full sonic potential of the Nuendo DAW software. They include advanced DSP processing for stereo and surround monitoring, and use Dante network protocol for flexible system design and expansion. Three 16-channel models with different I/O configurations are available, usable individually or in combination for up to 128 channels.



Outstanding Sonic Quality Delivers Full System Potential

24 bit/192 kHz hardware operation in the Nuage I/O units ensures that the outstanding sonic detail and depth of the Nuendo DAW come through without compromise. The Nuage I/O units also feature advanced JetPLL™ jitter reduction technology for extremely low jitter and superior AD/DA resolution. The overall result is simply outstanding sound, no matter how complex the mix or how much processing is applied.



True Integrated Monitoring with Ultra-low Latency

To artists and musicians trying to lay down tracks in the studio, monitoring latency can be a huge problem that interferes with concentration and stifles creativity. The Nuage I/O units make latency issues a problem of the past thanks to advanced audio interface DSP hardware and “True Integrated Monitoring™” that reduces monitoring latency to well below the perception threshold of even the most sensitive performer. True Integrated Monitoring™ works flawlessly with the Nuendo Control Room monitoring features, a 32 monitor bus cascade, and a 16x16 monitor matrix that contributes to expandability and easy setup.

* JET and Jitter Elimination Technology are trademarks of TC Applied Technologies Ltd.
* The JET technology is used under sublicense from TC Applied Technologies Ltd., and is the intellectual property of Sonopsis Ltd.

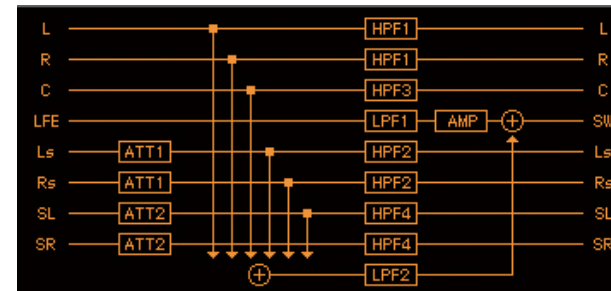

DSP Surround Processing

Surround processing capability is important in any post production system that will be used for a variety of projects. Nuage systems include all the essentials for state-of-the-art surround sound, including speaker level/delay adjustments and bass management.



Fuss-free, Flexible Network Connections

Dante is one of the most popular and well proven audio network protocols in use today, offering outstanding audio transmission quality and reliability as well as unrestricted system design and expandability. Because Nuage systems use Dante for system communication, connection between I/O unit and computer can be made via a single standard Ethernet cable. In more complex systems using multiple I/O units, standard network hubs and architecture can be used to configure the network as required. Flexible connectivity also means that a Nuage network can be linked to a live sound console, or included in a studio audio sharing installation.

Ultra-low latency and solid reliability with high channel counts

DANTE ACCELERATOR

The Dante Accelerator audio interface card can be installed in the computer running the Nuendo DAW to provide extra low-latency transfer of as many as 128 simultaneous channels of audio data, for a distinct performance advantage when communicating with Nuage I/O units. The Dante Accelerator card also features a secondary port that can be used to provide redundant connections* for failsafe reliability.

* Available with firmware update scheduled in Summer 2013



About Dante

Dante is a digital audio networking protocol developed by the Audinate company. The Dante protocol allows a maximum of 512 x 512 channels of digital audio (at 24 bits/48 kHz) to be transferred via standard Ethernet network infrastructure with extremely low latency. That plus the fact that it allows flexible network expansion have secured Dante's status as the leading next-generation digital audio transfer format.





The whole world of audio post in one powerful package.

NUENDO 6



Since its introduction in 2000, Nuendo has become a hugely popular audio production tool, empowering professionals in the film, advertising, television, and media industries with higher levels of productivity. Nuendo 6, the core of the Nuage system, is a milestone release that comes with an enviable selection of features not found in any other post-production software. EBU-compliant loudness measurement, some of the world's most advanced surround panning and up-mixing capabilities, and full ADR Taker functionality add to this remarkable DAW'S enormous production potential.



Mix Console



Channel Strip



ISONO Anymix Pro



ADR Setup



Brickwall Limiter

Top 10 Features of NUENDO 6

World's most dedicated audio post-production environment

A wealth of features for TV, film, advertising, games, and multimedia production.

Revolutionary new mixing console

New single-window concept and a cornucopia of workflow-accelerating functions.

NUENDO 6 ADR Taker

An ideal solution for voice recording and language dubbing, making external ADR redundant.

Fully integrated loudness measurement

EBU-compliant metering with a large choice of RMS metering scales and dedicated loudness lane.

ISONO Anymix Pro for state-of-the-art surround

The world's most flexible surround panner plus quality up-mixing algorithms.

NUENDO 6 Channel Strip

Enhanced mixes with direct access to professional channel strip modules.

VOXENGO Curve EQ with sound matching technology

The most accurate and infallible way to match the sound characteristics of one track to another.

Steinberg ASIO Guard

Extensive dropout-prevention techniques for maximum playback reliability.

Remote Control Editor

Assign individual effects and instrument parameters to the hardware control surface.

Pro Sound Effects post production library

1.5 gigabytes of top-quality 24-bit sound effects, from animals to Foley to warfare and more.

Sample-accurate timecode synchronization for audio and video.

NUENDO SYNCSTATION

Nuendo SyncStation is a hardware synchronizer that facilitates sample-accurate timecode synchronization between audio and video equipment. All Nuage interfaces include BNC and AES/EBU connectors for direct connection to SyncStation, as well as full support for the sample-accurate VST System Link.



- Sample-accurate time code synchronization when used with Nuendo.
- Allows MTP synchronization with many other DAWs (restrictions may apply according to DAW specifications and version).
- Cross platform support for Mac OS X and Windows (Mac OS X 10.7/10.8 and Windows 7 supported when used with Nuendo 6, as of November 2012).

* More details about Nuendo and Nuendo SyncStation can be found at the Steinberg web page: <http://www.steinberg.net>

Sample System

Mid-size Post-production Studio

Here's an example of a mid-size post-production studio that is based around Nuendo and one other DAW system. A small booth is available for voice recording, primarily for ADR applications, and full 5.1 monitoring is provided for surround sound support. The control room features two Nuage Fader units and one Nuage Master unit. Three Nuage I/O units in the machine room handle recording from the booth, send and return to and from outboard processors, and video I/O. Sound to picture synchronization is managed by a Nuendo SyncStation. Although Nuendo is the primary DAW for this studio, basic control of an alternative is possible when required.

Control Room

Machine Room

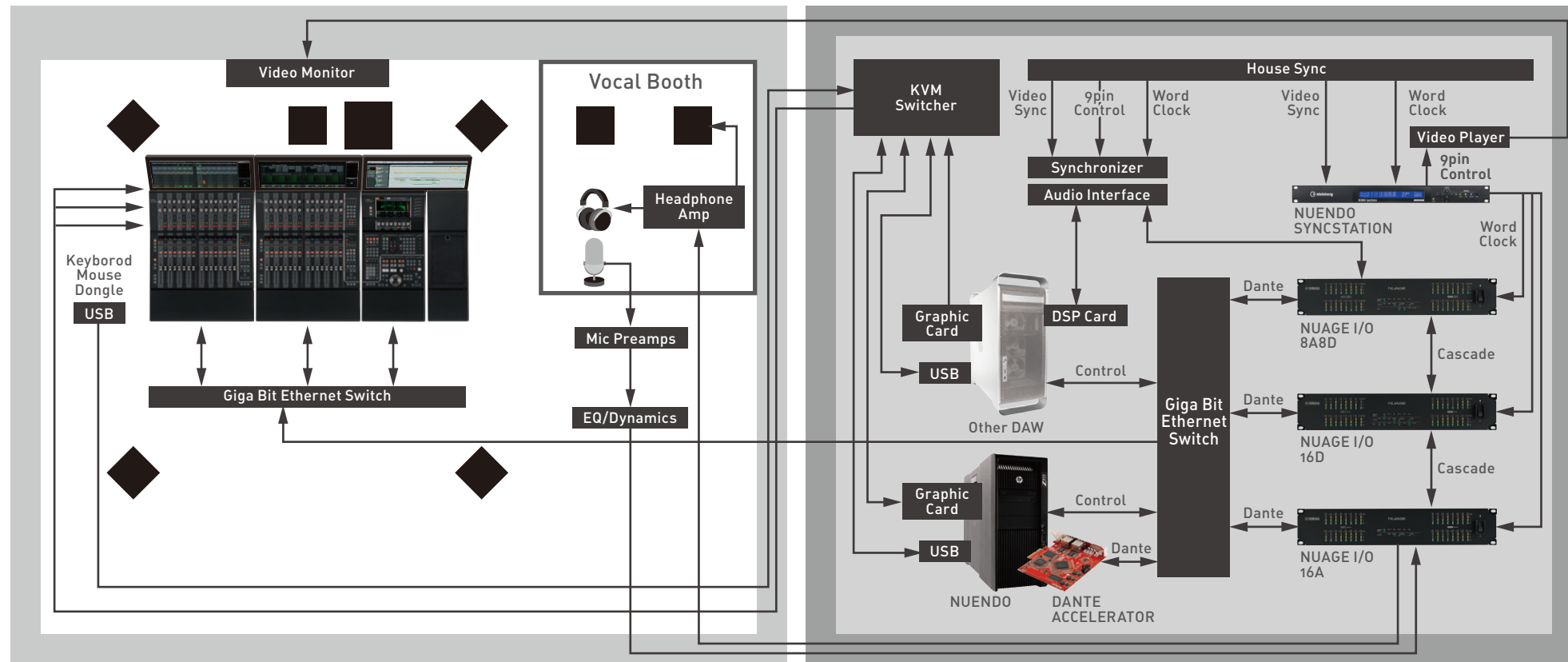

Configuration Examples

Small Scale Setup with 1x Nuage Fader



Small Scale Setup with 1x Nuage Master



Small Scale Setup with 1x Nuage Fader & 1x Nuage Master



Mid Scale Setup with 2x Nuage Fader & 1x Nuage Master



Large Scale Setup with 3x Nuage Fader & 1x Nuage Master



Additional Hardware for Nuage Systems

Nuage systems can be used with a variety of peripheral hardware and accessories to create working environments that are ideally tailored to individual needs. Here we have compiled a selection of items that Yamaha has tested and recommends for use with Nuage systems.

www.yamahaproaudio.com



Computer (Windows)
HP Z820 Workstation

This mini-tower workstation features the latest Intel architecture for fast, stable operation.



Computer (Mac)
Apple Mac Pro

Apple's fastest model, with up to 12 processor cores for blazing performance.



Monitor Display
HP ZR2440w

24" monitor display with white LED backlighting and high-resolution IPS LCD panel.

NUAGE I/O Specifications

General Specifications

Sampling Frequency	Internal	44.1kHz/48kHz/88.2kHz/96kHz/176.4kHz/192kHz	
	External	44.1kHz +4.1667%/+0.1%/-0.1%/-4.0%	±200ppm
Frequency Response	Internal	44.1kHz +4.1667%/+0.1%/-0.1%/-4.0%	±200ppm
	External	44.1kHz +4.1667%/+0.1%/-0.1%/-4.0%	±200ppm
THD+N *1	Less than 0.005%, input to output, GAIN:0dB		
Dynamic Range	120dB typ., ADC 120dB typ., DAC		
Crosstalk@1kHz	-100dB, CH1-16, adjacent inputs		
Power Requirements (wattage)	Nio500-D16: 51W Nio500-A16: 51W Nio500-A8D8: 51W		
Power Requirements (voltage and hertz)	US/Canada: 120V 60Hz Japan: 100V 50/60Hz China: 110-240V 50/60Hz Korea: 220V 60Hz Other: 110-240V 50/60Hz		
Dimensions (W x D x H)	480 x 372 x 88 mm		
Net Weight	Nio500-D16: 6.4kg(14.1lb) Nio500-A16: 6.7kg(14.1lb) Nio500-A8D8: 6.7kg(14.8lb)		
Included Accessories	Power cable, Ferrite core, Rubber stoppers (4), Operation Manual		

*1 These characteristics are measured with A-weighting filter and/or 30kHz LPF.

Analog I/O Characteristics

Terminal	Actual Load Impedance	For Use With Nominal	GAIN	Input level		Connector in Console
				Nominal	Max. before clip	
ANALOG INPUT	20KΩ (BAL)	150Ω Lines	0dB	+4dBu (1.23 V)	+24dBu (12.28V)	D-SUB Connector 25P (Female)
	10KΩ (UNBAL)	600Ω Lines	+12dB	-10dBV (0.32 V)	+10dBV (3.16V)	
ANALOG OUTPUT	75Ω(BAL)	10kΩ Lines	0dB	+4dBu (1.23 V)	+24dBu (12.28V)	D-SUB Connector 25P (Female)
			-6dB	-	+18dBu (6.16 V)	

Digital I/O Characteristics

Terminal	Format	Data length	Level	Connector in Console
AES/EBU	AES/EBU Professional use	24bit	RS422	D-SUB Connector 25P (Female)
Primary/Secondary	Dante	24bit	1000Base-T	RJ-45 x 2
Cascade	-	32bit	LVDS*2	RJ-45 x 2

Control I/O Characteristics

Terminal	Format	Level	Connector in Console
WORD CLOCK	IN	-	BNC Connector
	OUT	TTL/75Ω terminated	BNC Connector
System Link Out	-	1.0±0.2Vp-p/75Ω ³	BNC Connector

* 2 Hi Speed CML * 3 AES-31d



Graphics Card (Windows)
AMD FirePro V7900

A single-slot graphics card with impressive multi-display capabilities.



Graphics Card (Mac)
ATI Radeon HD 5870 for Mac

1 GB of GDDR5 memory in a high-performance graphic card for Mac computers.



Keyboard
Logic Keyboard

An ideal keyboard for Nuendo operation, with a wealth of assignable shortcut keys.



Surround Panner
JL Cooper MCS-Panner

JL Cooper's 3-axis joystick allows exceptionally smooth surround sound control.

Dimensions

NUAGE FADER (Ncs500-FD)

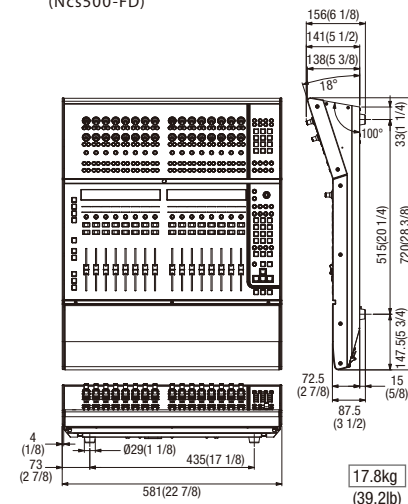

NUAGE MASTER (Ncs500-CT)

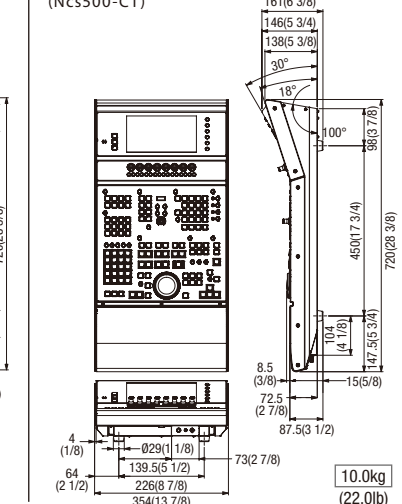

NUAGE WORKSPACE (Large) (Nws500-LG)

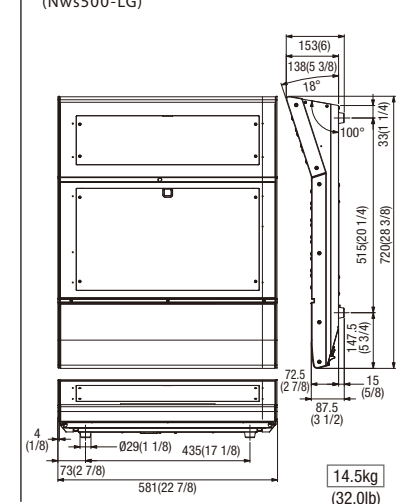

NUAGE WORKSPACE (Small) (Nws500-SM)

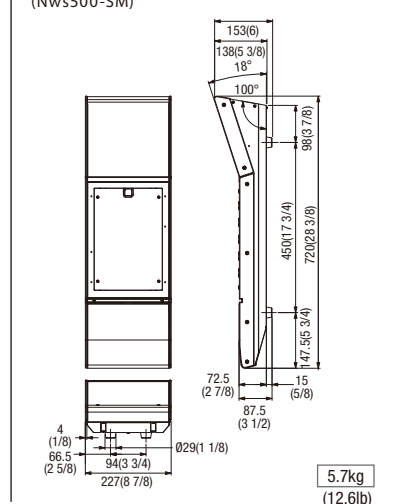

NUAGE I/O (16D/16A/8A8D) (Nio500-D16/Nio500-A16/Nio500-A8D8)

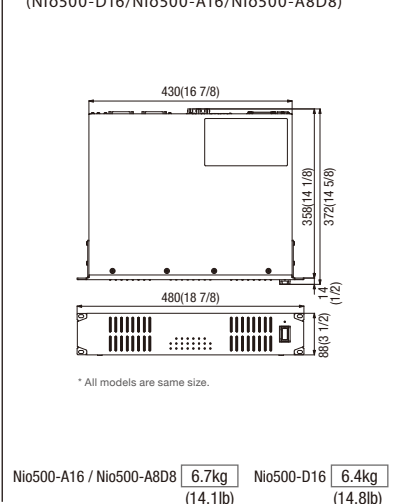

* All models are same size.



Display Arm
Ergotron LX Dual Side-by-Side Arm

This flexible, solidly constructed display arm is invaluable for multi-display systems.



KVM Switcher
Gefen 8x1DVI KVM DLSSL

Operate multiple DAWs from a single keyboard and mouse.



Custom Desk
Argosy Mirage for Nuage

Elegant studio furniture specifically designed to house Nuage systems.

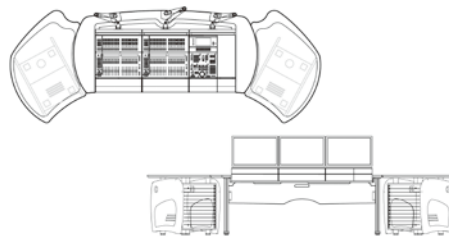

Custom Desk
ProWave system from AKA Design

ProWave Desk designed for Nuage with rack and table options.

The products introduced in the above list are NOT sold or supported by Yamaha. Refer to the respective manufacturers for information.

mm(inch)