

Model: UDEL-series

Utility Drawer – Economy, Locking

Description:

The UDEL-series of utility drawers feature fully welded construction of 16-gauge steel. The drawers mount to front rack rails using standard EIA spacing and feature ball-bearing slides for smooth operation. Drawers have a load capacity of 50 lbs. Smooth, black powder epoxy finish. Keylock on front.



UDEL utility drawers have a load capacity of 50 lbs. and a front keylock.

Features:

- Fully-welded 16-gauge US steel.
- Ball-bearing slides.
- Mounts on front rails of 19"W EIA rack.
- Load Capacity: 50 lbs.
- Smooth black powder epoxy finish.
- Front keylock.
- Made in the USA
- Plastic bushing in rear of drawer for plug or wire pass-through (up to 1.06" dia.)

Options:

- **DFI-series:** drawer foam inserts are designed to protect sensitive equipment. Die-cut foam is pre-scored so you can "pick and pull" sections to create custom holes that keep accessories from jostling when drawer is opened and closed. Insert includes two pieces (die-cut foam plus 3/8" foam pad for bottom). 15.5" x 14". Fits UDE, UDEL and UDP-series drawers.
 - **DFI-2:** for 2U drawer
 - **DFI-3:** for 3U drawer
 - **DFI-4:** for 4U drawer
- **CDM:** the cabinet drawer mat is a non-slip, perforated liner that provides a protective barrier between electronics accessories and the drawer's metal surface. 15.5" x 14".

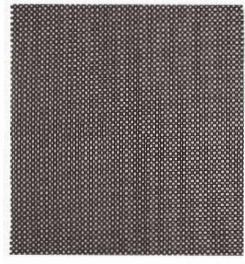

Optional non-slip drawer mat (CDM).



Create a custom-fit to cushion sensitive electronics with the optional (DFI) foam insert.

A & E Specifications:

The rackmount utility drawer shall be Lowell Model _____. It shall have a panel space height of _____ and shall be fully-welded, 16-gauge steel with a black powder epoxy finish. The drawer shall feature ball-bearing slides and have a load capacity of 50 lbs.

Model No.	Description	Rack Units	Depth	Overall Width	Load Capacity
UDEL-214	Utility Drawer, Economy – Locking	2	14.5"	19"	50 lbs.
UDEL-314	Utility Drawer, Economy – Locking	3	14.5"	19"	50 lbs.
UDEL-414	Utility Drawer, Economy – Locking	4	14.5"	19"	50 lbs.
DFI-2	Drawer Foam Insert (for 2U drawer)				
DFI-3	Drawer Foam Insert (for 3U drawer)				
DFI-4	Drawer Foam Insert (For 4U drawer)				
CDM	Cabinet Drawer Mat				

One rack unit = 1.75"

UDEL-214

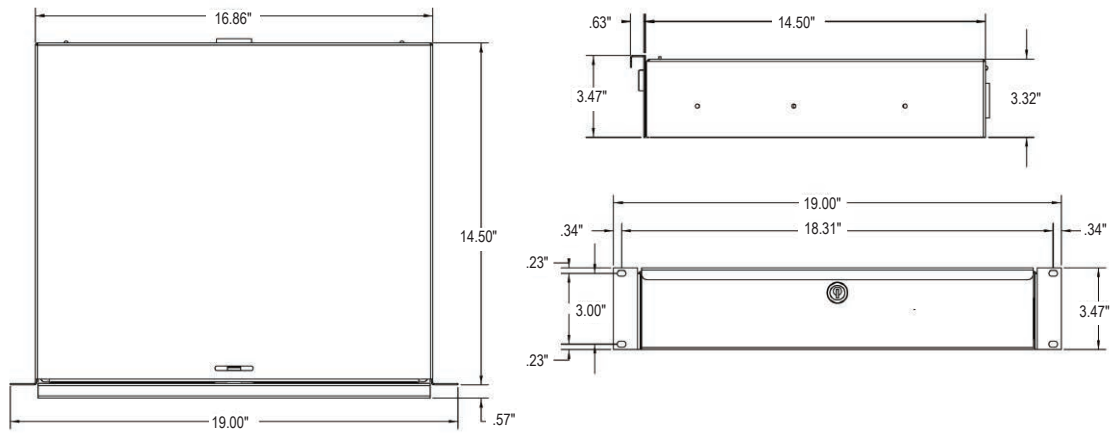

UDEL-314

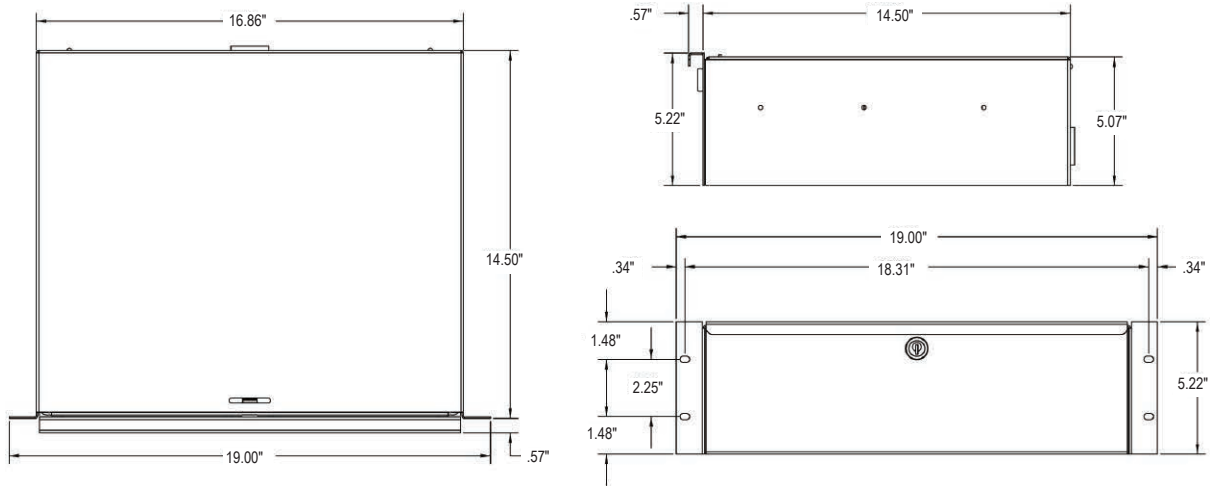

UDEL-414

