

SONY®

HD ELECTRONIC VIEWFINDER

HDVF-20A

HDVS

MAINTENANCE MANUAL

1st Edition

Serial No. 10001 and Higher

⚠ 警告

このマニュアルは、サービス専用です。
お客様が、このマニュアルに記載された設置や保守、点検、修理などを行うと感電や火災、人身事故につながる可能性があります。
危険をさけるため、サービストレーニングを受けた技術者のみご使用ください。

⚠ WARNING

This manual is intended for qualified service personnel only.
To reduce the risk of electric shock, fire or injury, do not perform any servicing other than that contained in the operating instructions unless you are qualified to do so. Refer all servicing to qualified service personnel.

⚠ WARNUNG

Die Anleitung ist nur für qualifiziertes Fachpersonal bestimmt.
Alle Wartungsarbeiten dürfen nur von qualifiziertem Fachpersonal ausgeführt werden. Um die Gefahr eines elektrischen Schlages, Feuergefahr und Verletzungen zu vermeiden, sind bei Wartungsarbeiten strikt die Angaben in der Anleitung zu befolgen. Andere als die angegebenen Wartungsarbeiten dürfen nur von Personen ausgeführt werden, die eine spezielle Befähigung dazu besitzen.

⚠ AVERTISSEMENT

Ce manuel est destiné uniquement aux personnes compétentes en charge de l'entretien. Afin de réduire les risques de décharge électrique, d'incendie ou de blessure n'effectuer que les réparations indiquées dans le mode d'emploi à moins d'être qualifié pour en effectuer d'autres. Pour toute réparation faire appel à une personne compétente uniquement.

X-RAY RADIATION WARNING

Be sure that parts replacement in the high voltage block and adjustments made to the high voltage circuits are carried out precisely in accordance with the procedures given in this manual.

Table of Contents

Manual Structure

Purpose of this manual	3 (E)
Relative manual	3 (E)
Contents	4 (E)

1. Service Overview

1-1. Location of Printed Circuit Boards	1-1 (E)
1-2. Connector Input/Output Signals	1-1 (E)
1-3. Replacing CRT	1-2 (E)
1-4. Disconnecting/Connecting Flexible Card Wire	1-3 (E)
1-5. Notes on Repair Parts	1-3 (E)
1-6. Circuit Description	1-4 (E)

2. Electrical Alignment

2-1. General Information for Electrical Adjustment	2-1 (E)
2-1-1. Notes on Adjustment	2-1 (E)
2-1-2. Equipment/Fixtures Required	2-1 (E)
2-1-3. Connection	2-1 (E)
2-1-4. Extending Viewfinder	2-2 (E)
2-1-5. Setting of the VF SCAN Mode	2-2 (E)
2-1-6. Setting of the Format	2-2 (E)
2-2. Power Supply Voltage Adjustment	2-3 (E)
2-3. Vertical Hold Adjustment	2-3 (E)
2-4. Horizontal Hold Adjustment	2-3 (E)
2-5. Horizontal Duty Adjustment	2-4 (E)
2-6. Heater Voltage Adjustment	2-4 (E)
2-7. Focus Adjustment	2-5 (E)
2-8. Picture Frame Adjustment	2-6 (E)
2-9. Bright Extent Adjustment	2-7 (E)
2-10. Horizontal Picture Positioning Adjustment	2-8 (E)
2-11. Peaking Level Adjustment	2-9 (E)
2-12. Clamping Level Adjustment	2-9 (E)
2-13. 4:3 Picture Frame Adjustment	2-10 (E)

3. Spare Parts

3-1. Exploded Views	3-1
3-2. Electrical Parts List	3-3
3-3. Supplied Accessories	3-9
3-4. Tools and Fixtures	3-9

4. Semiconductor Pin Assignments

5. Block Diagram

Overall Block	5-2
---------------------	-----

6. Schematic Diagrams

VF-70	6-1
DF-58	6-4
VDA-41	6-5
VR-266	6-5
Frame Wiring	6-6

7. Board Layouts

VF-70	7-1
DF-58	7-2
LP-105	7-2
VDA-41	7-2
VR-266	7-2

Manual Structure

Purpose of this manual

This manual is the maintenance manual for HD Electronic Viewfinder HDVF-20A. This manual describes the information items necessary when the unit is supplied and installed, items that premise the service based on the components parts such as alignment, schematic diagrams, board layouts and spare parts lists, assuming use of system and service engineers.

Relative manual

Besides this maintenance manual the following manual is available for this unit.

- **Operation Manual (Supplied with this unit)**

This manual is necessary for application and operation of this unit.

- **“Semiconductor Pin Assignments” CD-ROM (Available on request)**

This “Semiconductor Pin Assignments” CD-ROM allows you to search for semiconductors used in Communication System Solutions Network Company equipment.

Semiconductors that cannot be searched for on this CD-ROM are listed in the maintenance manual for the corresponding unit. The maintenance manual contains a complete list of all semiconductors and their ID Nos., and thus should be used together with the CD-ROM.

Part number: 9-968-546-XX

Contents

The following are summaries of the each section for understanding the manual.

Section 1 Service Overview

Describes information about board locations, connector input/output signals, cleaning and replacement of CRT.

Section 2 Electrical Alignment

Explains the general information for adjustment procedures and the electrical adjustments of this unit.

Section 3 Spare Parts

Describes parts list, exploded views and supplied accessories used in the unit.

Section 4 Semiconductor Pin Assignments

Contains information on semiconductors used for the unit.

It includes a complete list of the semiconductors and their ID Nos. for retrieving information on “Semiconductor Pin Assignments” CD-ROM, which is available separately.

Please refer to this section together with the “Semiconductor Pin Assignments” CD-ROM.

Information on the semiconductors not contained in the CD-ROM at the time of issue of this manual, if any, is given in this section as well.

Section 5 Block Diagram

Describes overall block diagram of this unit.

Section 6 Schematic Diagrams

Describes schematic diagrams for every circuit board and frame wiring .

Section 7 Board Layouts

Describes board layouts for every circuit board.

Section 1

Service Overview

1-1. Location of Printed Circuit Boards

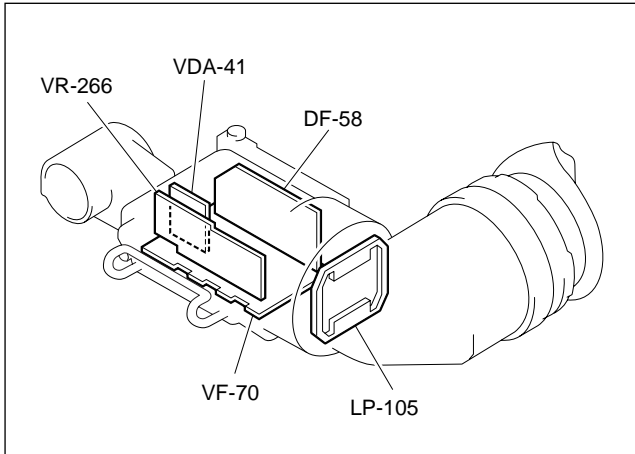

1-2. Connector Input/Output Signals

VF (20P MALE)

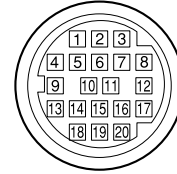

(EXTERNAL VIEW)

Pin No.	Signal	I/O	Specifications
1	S-DATA	IN/OUT	TTL level
2	NC		
3	POWER OFF CTL	IN	ON : OPEN OFF : GND
4	SCK	IN	TTL level
5	COLOR/BW	OUT	B/W : GND COLOR : OPEN
6	NC		
7	NC		
8	G TALLY	IN	ON : 5V OFF : GND
9	PEAKING CTL	OUT	VF to CAM ($R_o = 1\text{ k}\Omega$) 0 V to 5 V 0 V : PEAKING OFF 5 V : PEAKING MAX
10	NC		
11	NC		
12	Y VIDEO	IN	1.0 V p-p ($R_o = 75\text{ k}\Omega$)
13	VIDEO GND		
14	NC		
15	NC		
16	NC		
17	R TALLY	IN	ON : 5 V OFF : GND
18	NC		
19	UNREG GND		
20	UNREG		+10.5 V to 17 V

1-3. Replacing CRT

1. Loosen the screw of the MIC clamp and open the MIC clamp.
2. Remove the two screws (K2.6 × 4).
3. Remove the three hexagonal socket bolts (2.6 × 6) and remove the upper chassis.
4. Remove the two screws (P2 × 3.5) and the board bracket.

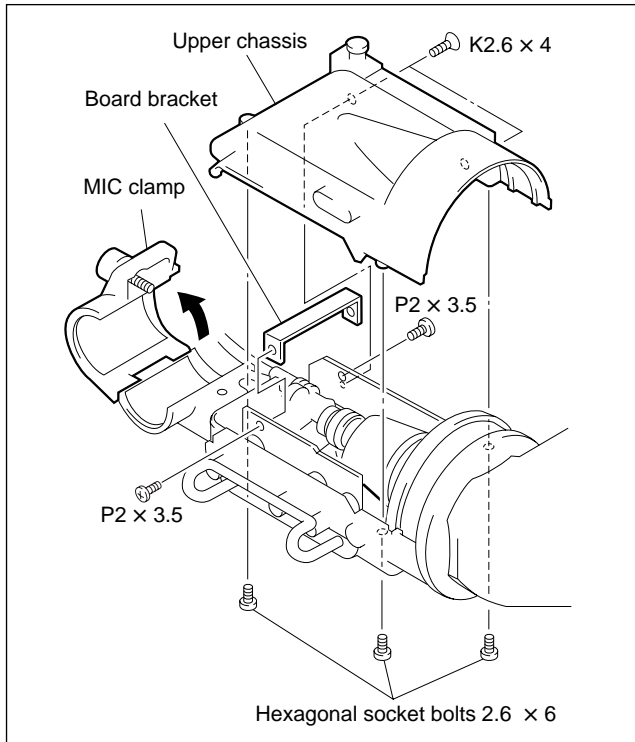

5. Disconnect the five connectors CN301, CN501 and CN502 on the VF-70 board, CN102 on the DF-58 board and CN263 on the VDA-41 board and the anode cable.

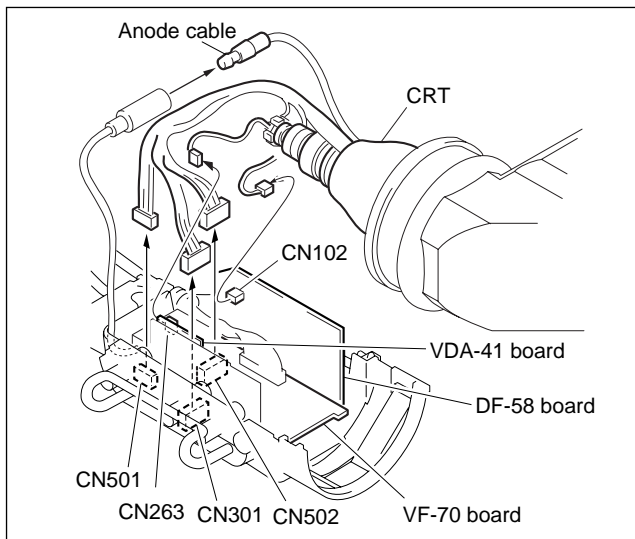

6. Remove the four screws and remove the CRT from the VF tube assembly.
7. Remove the CRT tube from the CRT.

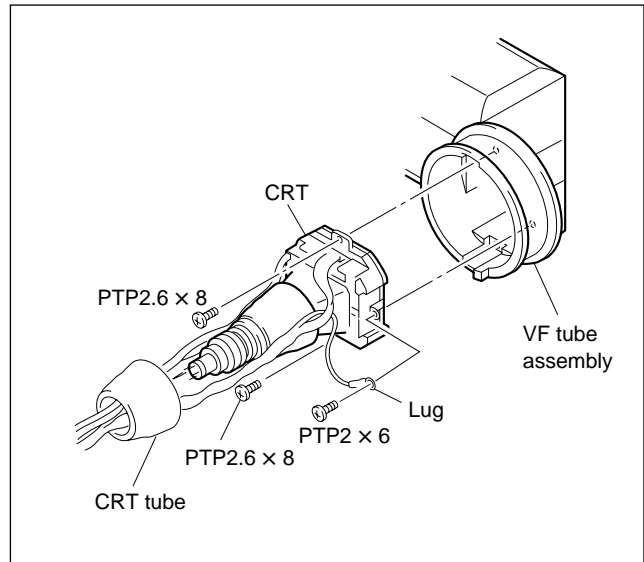

8. Remove the four screws and remove the microphone spacer.
9. Disconnect the connector CN21 on the LP-105 board.

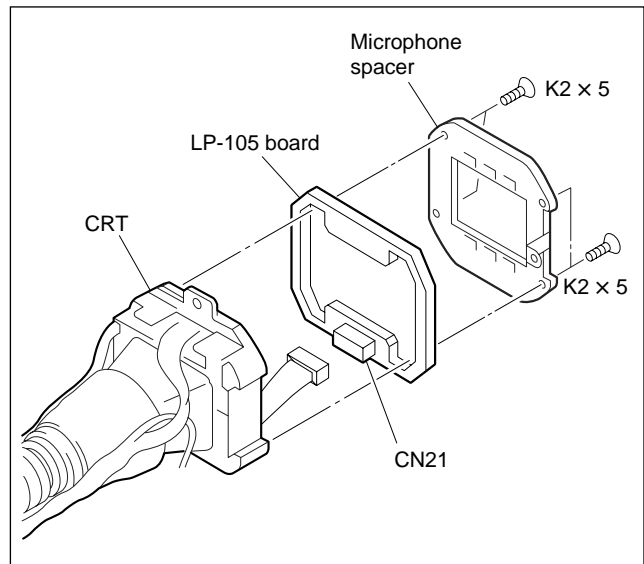

10. Install a new CRT in the reverse procedures of removal.

Note

When installing the upper chassis, take care not to catch the harness between upper and lower chassis.

1-4. Disconnecting/Connecting Flexible Card Wire

The flexible card wire is used between the VF-70 board and VR-266 board. Take care not to break this flexible card wire. This shorten the wire life.

Disconnecting

1. Turn off the power.
2. Slide portions A in the direction of the arrow to unlock and pull out the flexible card wire.

Connecting

Notes

- Be careful not to insert the flexible card wire obliquely.
 - Check that the conductive surface of the flexible card wire is not soiled with dust.
1. Slide portions A in the direction of the arrow and insert the flexible card wire as far as it will go with the conductive surface down.
 2. Slide portions A in the reverse direction to lock.

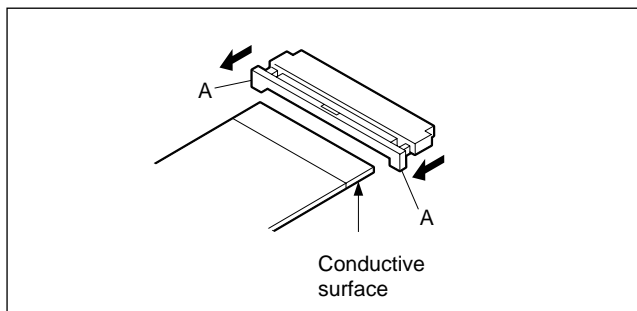

1-5. Notes on Repair Parts

1. Safety Related Components Warning

WARNING

Components marked \triangle are critical to safe operation. Therefore, specified parts should be used in the case of replacement.

2. Standardization of Parts

Some repair parts supplied by Sony differ from those used for the unit. These are because of parts commonality and improvement.

Parts list has the present standardized repair parts.

3. Stock of Parts

Parts marked with "o" at SP (Supply Code) column of the spare parts list may not be stocked. Therefore, the delivery date will be delayed.

4. Units Representation

The following represented units are changed or omitted in writing.

Units		Representation
Capacitance	μ F	uF
Inductance	μ H	uH
Resistance	Ω	Abbreviation
Temperature	$^{\circ}$ C	XXX-DEG-C

1-6. Circuit Description

VF-70 board

The VF-70 board consists of a power supply block, H deflection drive circuit and serial interface circuit for various controls.

A switching regulator consists of IC401 and Q401 to Q404, where +9.5 V and about +7.5 V for H driving are generated from UNREG (10.5 to 17 V) input at pin B10 of CN001. And H size adjustment is performed by controlling the reference dc voltage for IC401 with RV110 (H SIZE) on the DF-58 board.

The H deflection circuit IC501 and Q501 are also used to drive a flyback transformer. The flyback transformer outputs HV (6 kV), G2 (500 V), 60 V and heater pulse voltage. The heater pulse voltage is smoothed by C513, and is adjusted in voltage by RV501 (HEATER). The resultant is applied to the heater through IC503.

The voltage for feedback circuit is output at pin 1 of the flyback transformer and is sent to a feedback circuit consisting of IC501, IC502, Q502 and Q503 to stabilize a high-voltage portion. When the voltage goes higher than the reference, the power is turned off as pin 8 of IC502 goes high and a protection circuit operates.

IC301 and IC302 are serial interface ICs, which are used to control indicators and to grab switch data and so on.

IC304 is a timer IC. It is used to set the time period during which the zebra pattern is displayed in MOMENTARY mode, and during which the brightness increases momentarily as the internal tally signal is turned on.

DF-58 board

The DF-58 board provides an external sync circuit, V deflection drive circuit and blanking pulse generation circuit.

IC104 is a sync separator, which separates sync signals from the video signal input to the DF-58 board and outputs the HD signal from pin 7 and VD signal from pin 3. The HD signal is compared in phase with a flyback pulse at IC101 and then enters AFC circuit.

The VD signal is input to pin 21 of IC101, and is then sent to the V deflection drive circuit consisting of Q104 to Q107 as a trigger pulse.

IC106 generates a video clamp pulse, and IC108 to IC115 generate a beam blanking pulse. These pulses are output to the VF-70 board.

VR-266 board

The VR-266 board consists of a video amplifier circuit and bright control circuit.

The video signal input at pin 3 of CN201 is adjusted in level with RV201 (CONTRAST), and is sent through the peaking circuit to the VDA-41 board.

DC voltage is adjusted with RV205 and RV206 (BRIGHT) and is sent to the VF-70 board as a bright control voltage.

VDA-41 board

The video signal from the VR-266 board is shifted by a constant voltage at D261 zener diode. And then the video signal is amplified by Q261 and Q262, and is output to G1 through a drive circuit of Q263 to Q266. Q267 clamps the blanking portion to stabilize the black level.

Section 2

Electrical Alignment

2-1. General Information for Electrical Adjustment

2-1-1. Notes on Adjustment

WARNING

There is a danger of an electric shock around the CRT due to its high voltage. Great care should be taken in servicing. Never touch a live CRT by bare hands.

Before performing adjustment, read throughly the following comments.

- Calibration for all measuring equipment should be completed.
- Alignment of peripheral equipment such as camera should be completed.

2-1-2. Equipment/Fixtures Required

Equipment

- HDVS camera system
HDC-950 or HDW-F900
- AC adaptor
AC-550/550CE or equivalent
- Oscilloscope
(Input capacitance of probe : 12 pF or below)
Tektronix 2465B or equivalent
- HDTV waveform monitor
Tektronix 1735HD/1730HD or equivalent
- HDTV B/W monitor
- Digital voltmeter
- Frequency counter

Fixtures

Fixtures	Sony P/N
Pattern box PTB-500	J-6029-140-B
Resolution chart (16:9)	J-6395-320-A
VF extension harness	J-6395-050-A

2-1-3. Connection

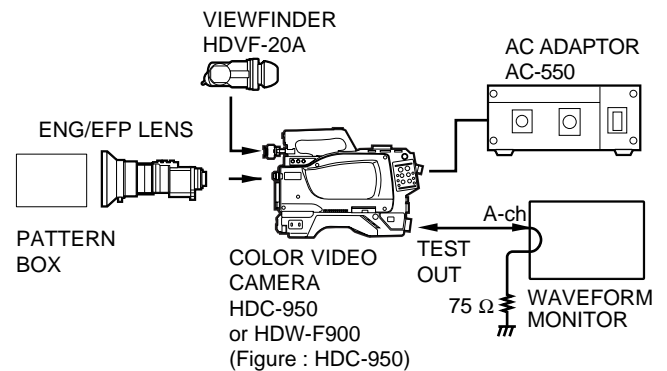

2-1-4. Extending Viewfinder

1. Turn off the power before performing adjustment.
2. Remove the viewfinder from the camera.
3. Open the MIC clamp and remove the upper chassis. (Refer to Section 1-3 "Replacing CRT" for details.)

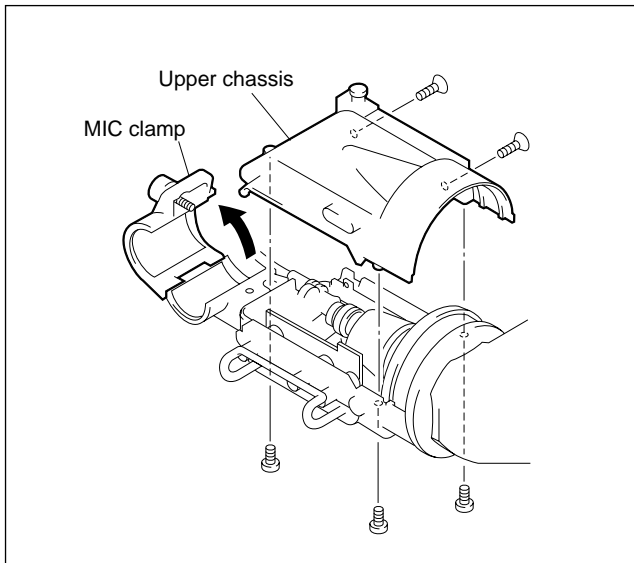

4. Connect the viewfinder to the camera via the VF extension harness.
5. Turn on the power.

2-1-5. Setting of the VF SCAN Mode

1. Before adjustment, set the VF SCAN mode to 16:9 following to the camera's setup menu. (Refer to HDC-950 or HDW-F900 Operation Manual for details.)
MENU : Operation
PAGE : VF Setup
ITEM : VF Scan → 16:9
2. Whenever you press DISPLAY/SCAN switch on the viewfinder to SCAN, the picture frame mode toggles between 16:9 and 4:3. Perform the adjustment in 16:9 mode unless otherwise specified.

2-1-6. Setting of the Format

There are some items which need adjusting by switching among the each formats of 60i, 50i and 48i. As for the switching method of the format, refer to the HDC-950 or HDW-F900 Operation manual. Adjust in the 60i mode unless any specification exists.

2-2. Power Supply Voltage Adjustment

Equipment : Digital voltmeter

Adjustment Procedure

Test point : CN101-1pin/DF-58
 Adjustment point : ●RV401/VF-70
 Specification : 9.50 ± 0.05 V dc

2-3. Vertical Hold Adjustment

Equipment : Frequency counter

Adjustment Procedure

Switch the format to 60i, 50i and 48i by the camera and adjust the following RVs corresponding to each format.

Test point : CN102-1pin/DF-58
 GND : Shielding case of FBT501/VF-70
 Adjustment point : ●RV105/DF-58 (60i)
 ●RV117/DF-58 (50i)
 ●RV118/DF-58 (48i)
 Specification : 55.0 ± 0.5 Hz

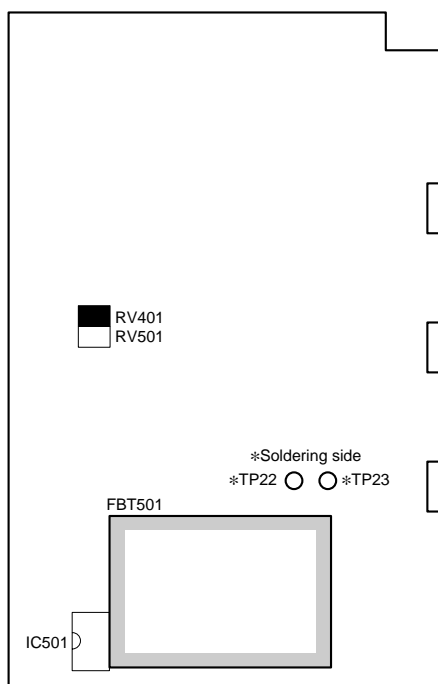

VF-70 - component side -

2-4. Horizontal Hold Adjustment

Equipment : Frequency counter

Adjustment Procedure

Switch the format to 60i, 50i and 48i by the camera and adjust the following RVs corresponding to each format.

Test point : CN101-7pin/DF-58
 GND : Shielding case of FBT501/VF-70
 Adjustment point : ●RV103/DF-58 (60i)
 ●RV115/DF-58 (50i)
 ●RV116/DF-58 (48i)
 Specification : 33.75 ± 0.25 kHz

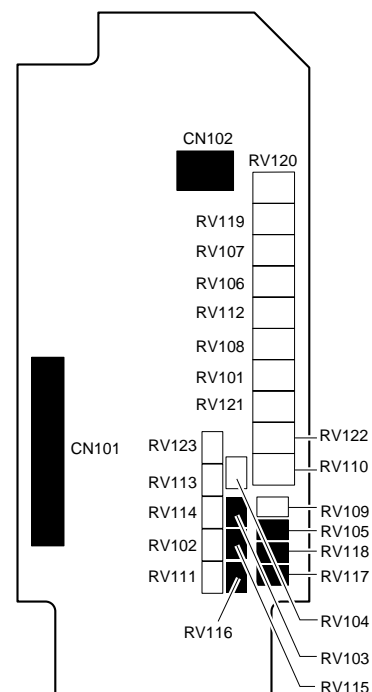

DF-58 - component side -

2-5. Horizontal Duty Adjustment

Equipment : Oscilloscope

Preparations

- Iris of the lens : CLOSE
- BRIGHT control : Fully counterclockwise ☯
- CONTRAST control : Fully counterclockwise ☯
- PEAKING control : Fully counterclockwise ☯

Adjustment Procedure

Test point : IC501-7pin/VF-70
 GND : Shielding case of FBT501/VF-70
 Adjustment point : ⚙RV104/DF-58
 Specification : $T = 2.9 \pm 0.1 \mu\text{s}$
 Turn ⚙RV104 fully counterclockwise, and slowly turn it clockwise until the specification is satisfied.

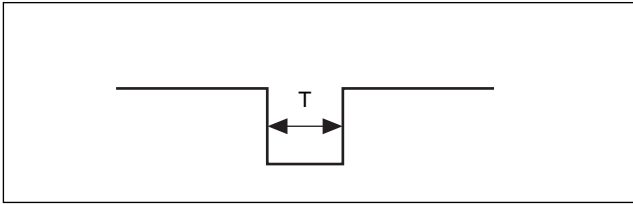

Note

If T is set to $2.5 \mu\text{s}$ or below, high-voltage protection circuit may become activated. In this case, power off once and turn ⚙RV104/DF-58 fully counterclockwise. After that power on again to perform the adjustment.

2-6. Heater Voltage Adjustment

Equipment : Digital voltmeter

Note

During adjustment, do not set heater voltage to 700 mV or over.

Preparations

- BRIGHT control : Mechanical center
- CONTRAST control : Mechanical center
- PEAKING control : Mechanical center

Adjustment Procedure

Test point : TP22/VF-70
 GND : TP23/VF-70
 Adjustment point : ⚙RV501/VF-70
 Specification : $650 \pm 30 \text{ mV dc}$
 Turn ⚙RV501 fully clockwise, and slowly turn it counterclockwise until the specification is satisfied.
 (Do not set heater voltage to 700 mV or over.)

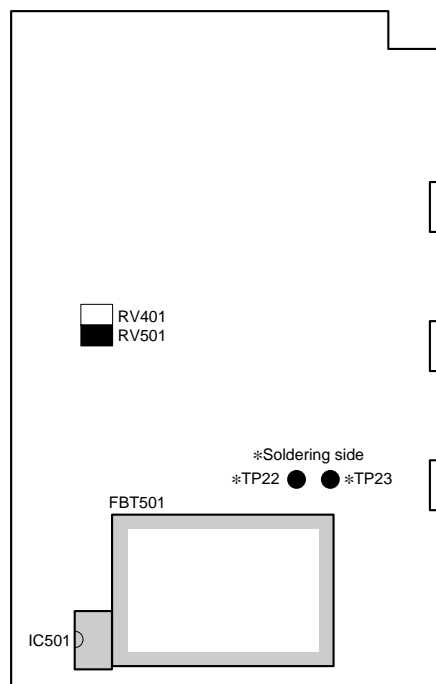

VF-70 - component side -

2-7. Focus Adjustment

Subject : Resolution chart

Note

This focus adjustment, “2-8. Picture Frame Adjustment” and “2-9. Bright Extent Adjustment” affect each other. Therefore, repeat these adjustments until all specifications are satisfied.

Preparations

- Shoot the resolution chart so that the chart frame is aligned with the underscanned monitor frame with the zoom control.

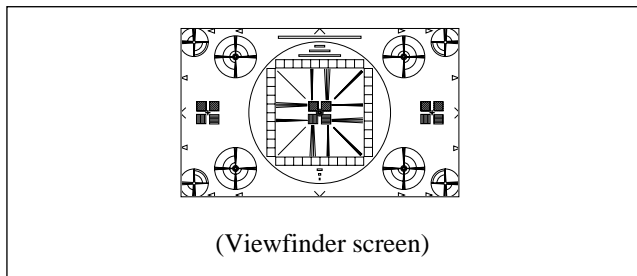

- Adjust the iris of the lens so that the output level (Y level) at TEST OUT connector on the camera is 500 ± 50 mV.
- BRIGHT control : Mechanical center
- CONTRAST control : Mechanical center
- PEAKING control : Fully counterclockwise ☺

Adjustment Procedures

1. Adjustment point : ⚙RV109/DF-58
Specification : Turn ⚙RV109 fully counterclockwise, and slowly turn it clockwise until the optimum focus is achieved.
2. After the adjustment, confirm that the focus can be achieved at all settings of BRIGHT, CONTRAST and PEAKING controls.

Notes

- If the picture frame adjustment is out of specifications, especially in horizontal size, the focus may not be achieved. In this case, turn ⚙RV112/DF-58 clockwise a little (referring to Section 2-8), and perform the focus adjustment.
- The application of too-high voltage may make the high-voltage protection circuit activated. In this case, power off once and turn ⚙RV109/DF-58 fully counterclockwise. After that power on again to perform the adjustment.

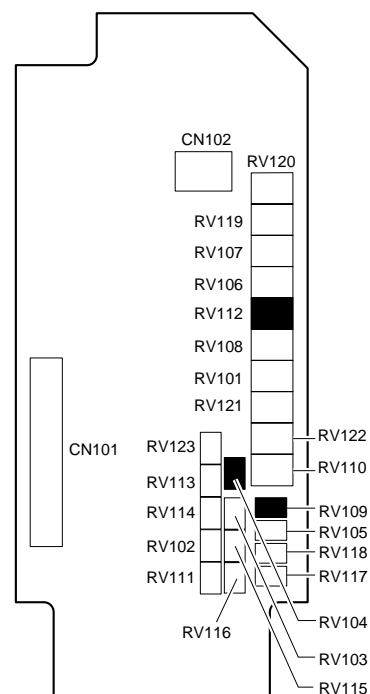

2-8. Picture Frame Adjustment

Subject : Resolution chart

Note

This picture frame adjustment, “2-7. Focus Adjustment” and “2-9. Bright Extent Adjustment” affect each other. Therefore, repeat these adjustments until all specifications are satisfied.

Preparations

- Shoot the resolution chart so that the chart frame is aligned with the underscanned monitor frame with the zoom control.

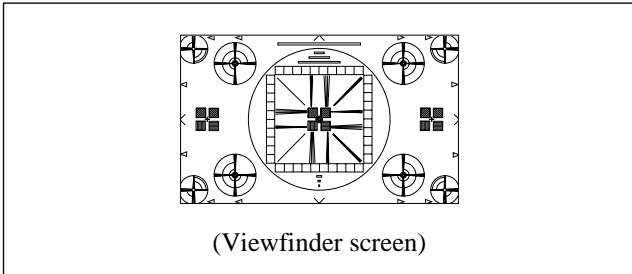

- Adjust the iris of the lens so that the output level (Y level) at TEST OUT connector on the camera is 500 ± 50 mV.
- BRIGHT control : Mechanical center
- CONTRAST control : Mechanical center
- PEAKING control : Fully counterclockwise ☺

Adjustment Procedures

1. Vertical Linearity Adjustment

Adjustment point : ●RV108/DF-58

Specification : Minimize the distortion of the four circles at the corners of the resolution chart.

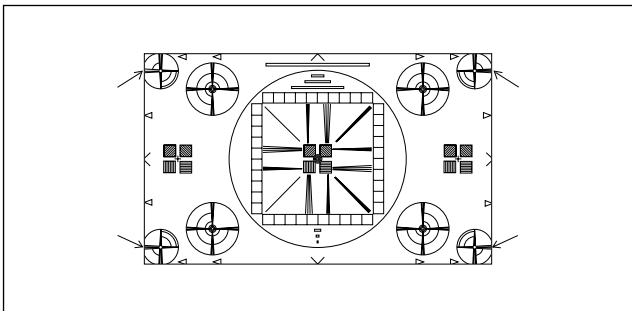

- Adjustment points : ●RV112/DF-58
●RV106/DF-58
●Centering magnet

Specification : Adjust ●RV112 and ●RV106 so that the chart frame position within the CRT frame is as shown below. Turn the centering magnet only when centering the chart.

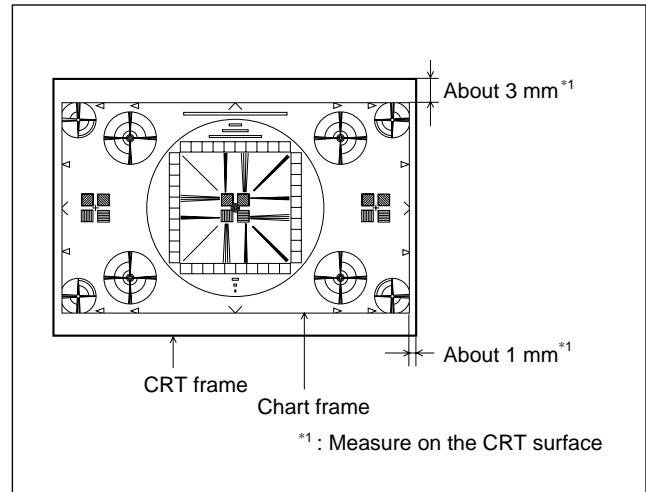

- Press the portion A to the lower chassis as shown below to recreate the same situation as when the upper chassis is installed to the viewfinder, and confirm that the picture is positioned in the center of the viewfinder.

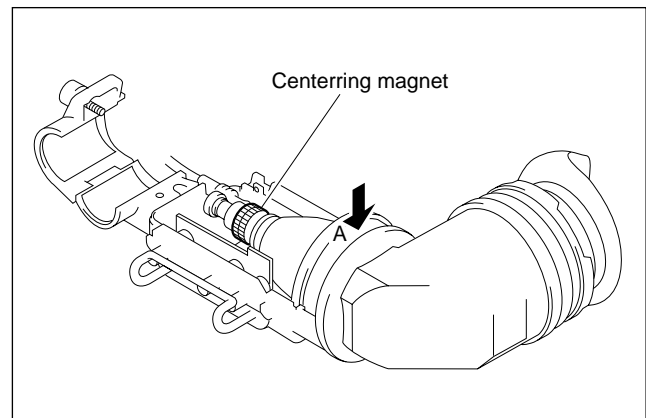

2-9. Bright Extent Adjustment

Subject : Resolution chart

Note

This bright extent adjustment, “2-7. Focus Adjustment” and “2-8. Picture Frame Adjustment” affect each other. Therefore, repeat these adjustments until all specifications are satisfied.

Preparations

- Shoot the resolution chart so that the chart frame is aligned with the underscanned monitor frame with the zoom control.

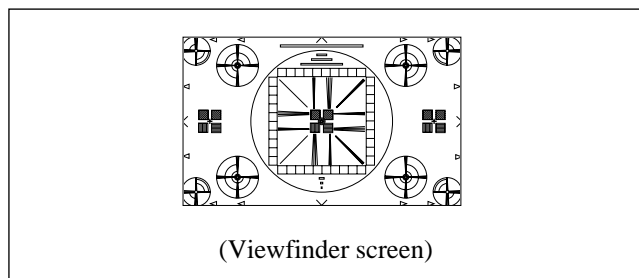

- Adjust the iris of the lens so that the output level (Y level) at TEST OUT connector on the camera is 500 ± 50 mV.
- BRIGHT control : Fully counterclockwise ☉
- CONTRAST control : Fully counterclockwise ☉
- PEAKING control : Fully counterclockwise ☉

Adjustment Procedure

Switch the format to 60i, 50i and 48i by the camera and adjust the following RVs corresponding to each format.

- Adjustment point : ●RV205/VR-266 (60i)
 ●RV207/VR-266 (50i)
 ●RV208/VR-266 (48i)
- Specification : The central circle of the resolution chart shall be barely discriminated.

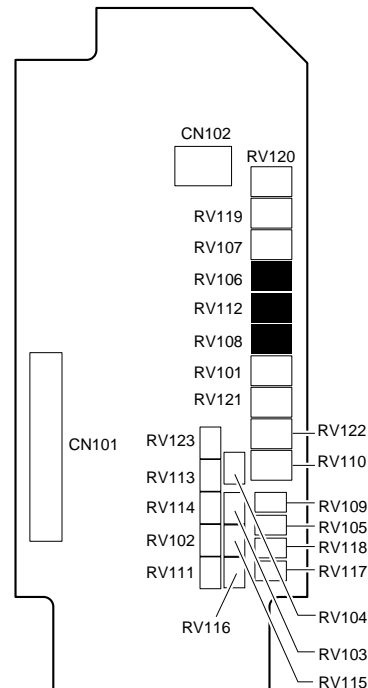

DF-58 - component side -

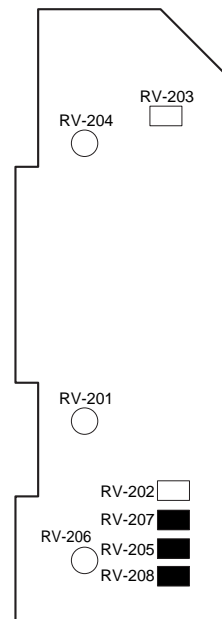

VR-266 - component side -

2-10. Horizontal Picture Positioning Adjustment

Subject : Resolution chart

Preparations

- Shoot the resolution chart so that the chart frame is aligned with the underscanned monitor frame with the zoom control.

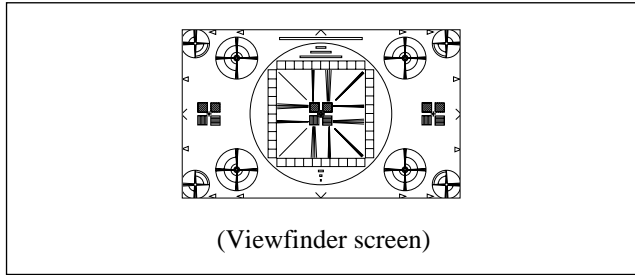

- Adjust the iris of the lens so that the output level (Y level) at TEST OUT connector on the camera is 500 ± 50 mV.
- BRIGHT control : Fully clockwise \odot
- CONTRAST control : Fully counterclockwise \ominus
- PEAKING control : Fully counterclockwise \ominus

Adjustment Procedure

Switch the format to 60i, 50i and 48i by the camera and adjust the following RVs corresponding to each format.

- Adjustment point :
- \odot RV101/DF-58 (60i)
 - \odot RV121/DF-58 (50i)
 - \odot RV122/DF-58 (48i)

Specification : Adjust the position of the resolution chart for A = B

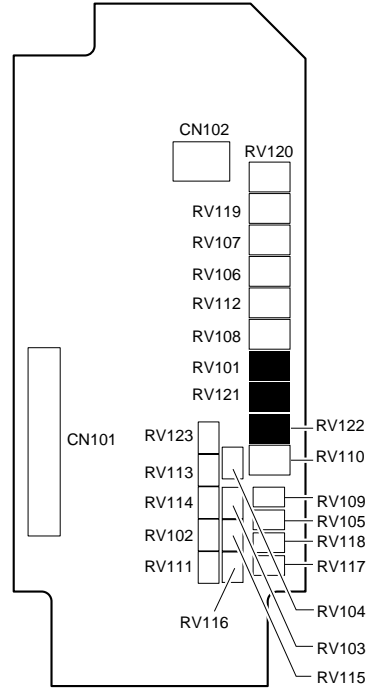
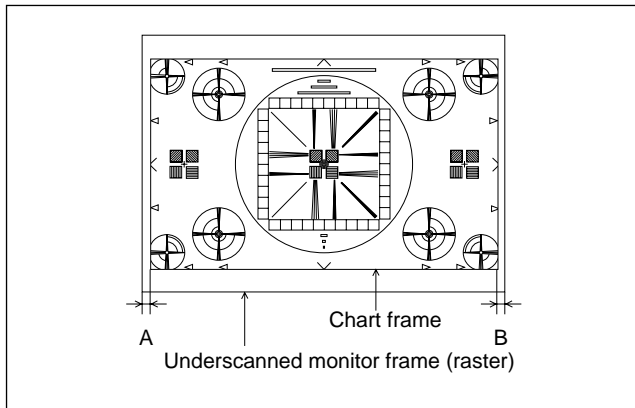

DF-58 - component side -

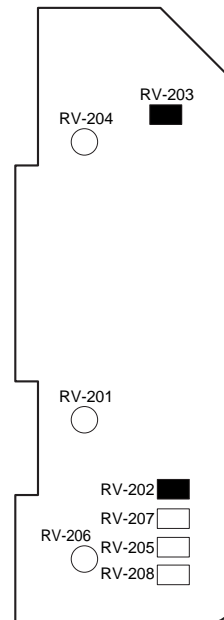

VR-266 - component side -

2-11. Peaking Level Adjustment

Equipment : Oscilloscope
Subject : Resolution chart

Preparations

- Shoot the resolution chart so that the chart frame is aligned with the underscanned monitor frame with the zoom control.

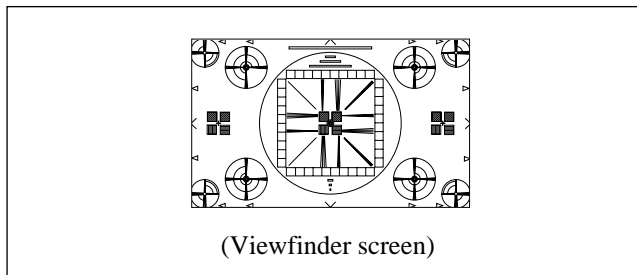

- Adjust the iris of the lens so that the output level (Y level) at TEST OUT connector on the camera is 500 ± 50 mV.
- BRIGHT control : Mechanical center
- CONTRAST control : Mechanical center
- PEAKING control : Fully counterclockwise \odot

Adjustment Procedure

Test point : TP261/VDA-41
GND : Viewfinder cabinet
Adjustment point : \odot RV203/VR-266
Specification : The waveform level A shall not change at all settings of PEAKING control.

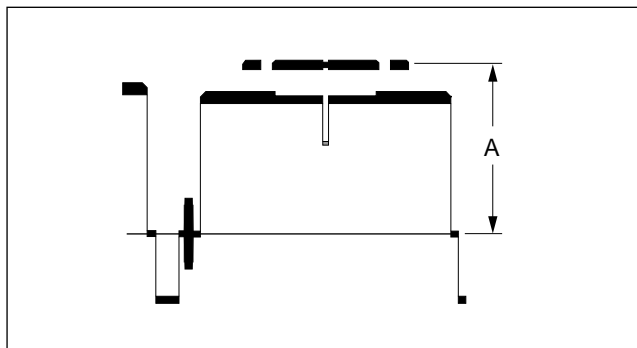

2-12. Clamping Level Adjustment

Equipment : Oscilloscope (DC mode)
(Input capacitance of probe : 12 pF or below)
Subject : Resolution chart

Preparations

- Shoot the resolution chart so that the chart frame is aligned with the underscanned monitor frame with the zoom control.

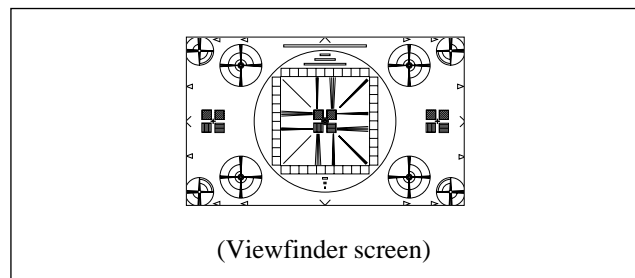

- Adjust the iris of the lens so that the output level (Y level) at TEST OUT connector on the camera is 500 ± 50 mV.
- BRIGHT control : Mechanical center
- CONTRAST control : Mechanical center
- PEAKING control : Fully counterclockwise \odot

Adjustment Procedure

Test point : TP261/VDA-41
GND : Grounding plate/VR-266
Adjustment point : \odot RV202/VR-266
Specifications : Adjust the overshoot A for 9 ± 1 V.
Check to see that blanking B is from 5 V to 20 V.

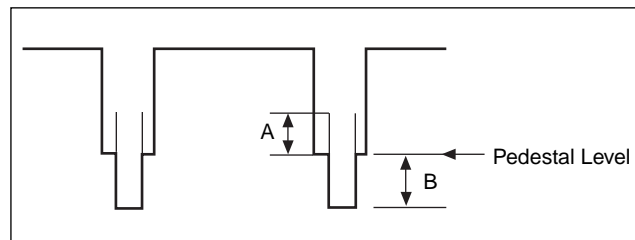

VDA-41 - soldering side -

2-13. 4:3 Picture Frame Adjustment

Subject : Full white pattern

Preparations

- Shoot the fully occupied white area in the underscanned monitor frame with the zoom control.
- Adjust the iris of the lens so that the output level (Y level) at TEST OUT connector on the camera is 350 ± 35 mV.
- BRIGHT control : Fully clockwise \odot
- CONTRAST control : Mechanical center
- PEAKING control : Mechanical center
- Press the DISPLAY/ASPECT switch to ASPECT to enter the 4:3 mode.

Adjustment Procedure

Adjustment points : \bullet RV102 (4:3 PHASE)/DF-58

\bullet RV111 (4:3 SIZE)/DF-58

Specifications : Adjust the 4:3 picture frame for
 $A = 2 \pm 1$ mm with \bullet RV102 and
 \bullet RV111. (Adjust the gray area)

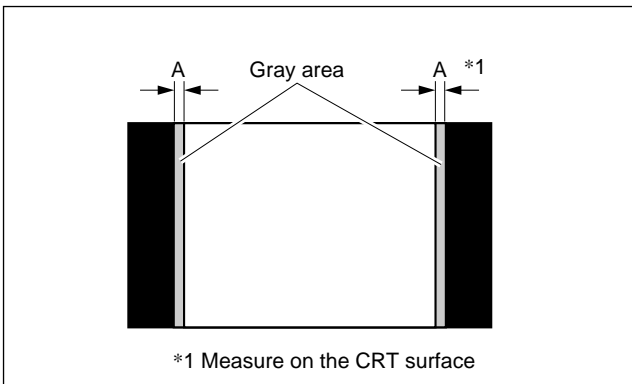

Setting after Adjustment

Press the DISPLAY/ASPECT switch to ASPECT to return the 16:9 mode.

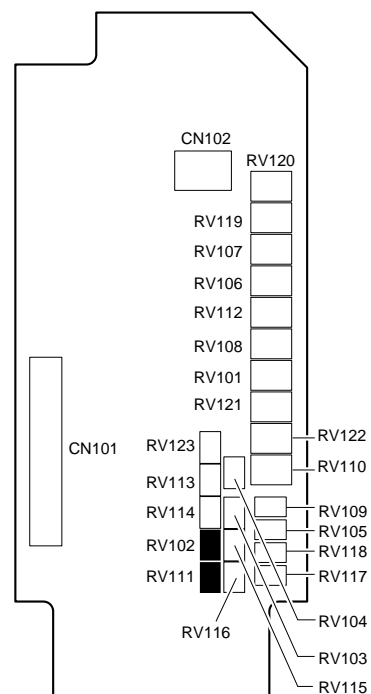

DF-58 - component side -

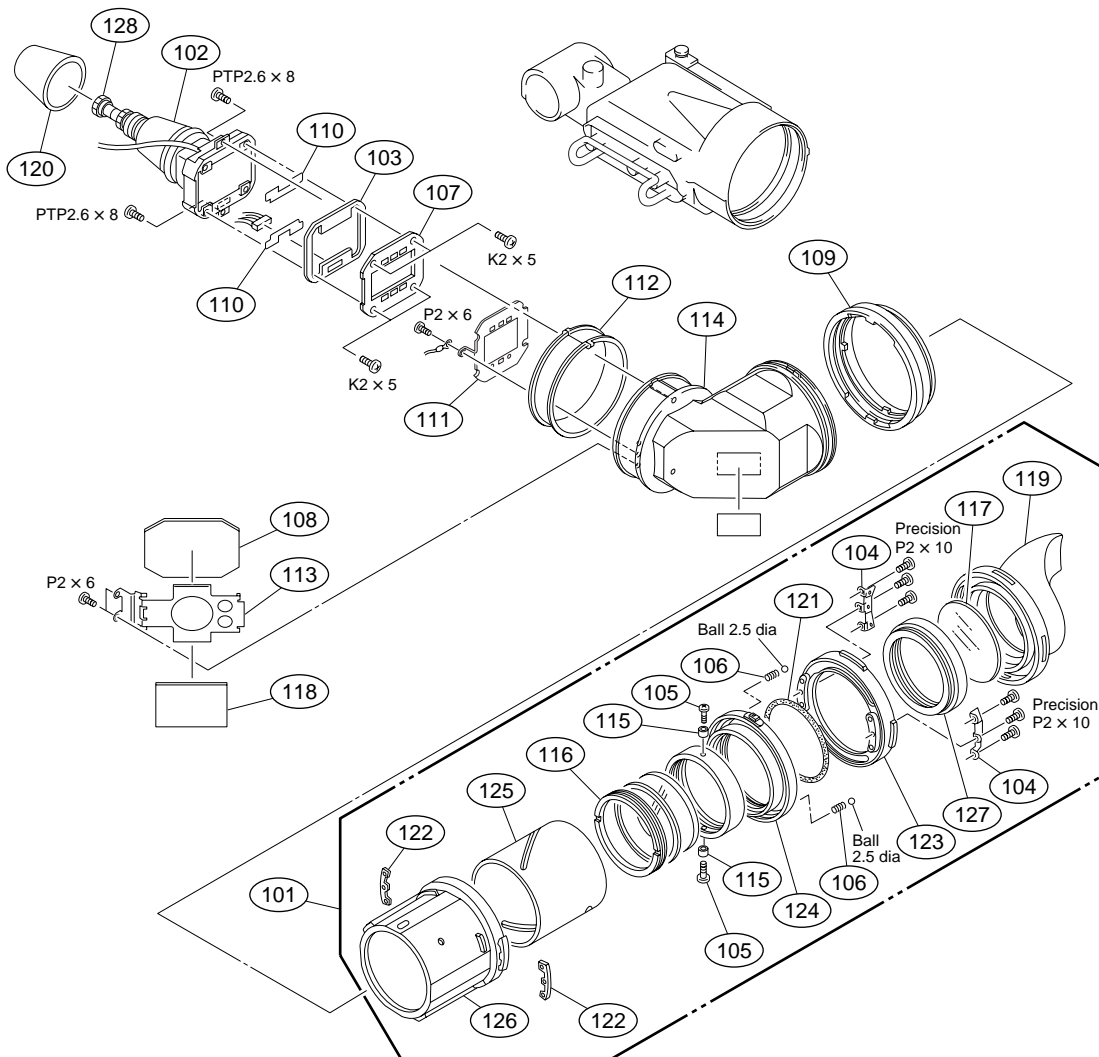

No.	Part No.	SP Description	No.	Part No.	SP Description
101	A-7612-389-B	s TUBE SUB ASSY, VF	118	3-723-073-01	o CUSHION, MIRROR
102	△ 1-251-636-11	s CRT ASSY, 2" HD	119	A-8319-943-A	s EYE CUP (RP)
103	A-8315-579-A	o MOUNTED CIRCUIT BOARD, LP-105	120	3-725-220-02	o TUBE (A), CRT
104	3-176-414-01	o RETAINER, RING	121	3-726-904-01	o RING (MT), O
105	3-335-207-01	s SHAFT, MOTOR	122	3-742-038-01	o NUT (2), PLATE
106	3-573-150-00	o SPRING, COMPRESSION	123	3-742-052-03	o HOLDER, EYECUP
107	3-603-499-02	s SPACER, MASK	124	3-742-053-02	o RING
108	3-608-806-01	o MIRROR (3)	125	3-742-054-01	o TUBE
109	3-692-136-03	o FIXED RING	126	3-742-060-01	o HOLDER, RING
110	3-692-144-01	o SPACER, LP	127	3-623-709-01	o MC HOLDER
111	3-697-159-02	o PLATE A, DISPLAY	128	9-885-005-86	o SOKET, CRT
112	3-697-151-01	o RING, VF		7-627-452-38	s SCREW, PRECISION +K 2X5
113	3-697-154-01	o HOLDER, MIRROR (3)		7-627-553-78	s SCREW, PRECISION +P 2X10
114	3-697-167-03	o VF TUBE (4)		7-671-158-01	s BALL, STAINLESS (2.5 DIA)
115	3-722-485-01	o ROLLER, SLIDE		7-685-104-19	s SCREW +P 2X6 TYPE2 NON-SLIT
116	3-722-492-01	o HOLDER (B), LENS		7-685-134-19	s SCREW +PTP 2.6X8 TYPE2 NON-SLIT
117	3-623-710-01	o MC, GLASS		7-685-104-14	s SCREW +P 2X6 TYPE2 NON-SLIT

3-2. Electrical Parts List

DF-58 Board

Ref. No. or Q'ty	Part No.	SP	Description
1pc	1-761-334-11	o	MOUNTED CIRCUIT BOARD, DF-58
C101	1-115-581-11	s	TANTALUM,CHIP 100uF 20% 16
C102	1-104-913-11	s	TANTALUM, CHIP 10uF 20% 16V
C103	1-115-581-11	s	TANTALUM,CHIP 100uF 20% 16
C104	1-163-251-11	s	CERAMIC, CHIP 100PF 5% 50V
C105	1-164-691-11	s	CERAMIC 0.0024uF 5% 50V
C106	1-163-135-00	s	CERAMIC 560PF 5% 50V
C107	1-164-182-11	s	CERAMIC 0.0033uF 10% 50V
C108	1-135-091-00	s	TANTALUM, CHIP 1uF 20% 16V
C109	1-135-091-00	s	TANTALUM, CHIP 1uF 20% 16V
C110	1-104-551-11	s	FILM 0.01uF 5% 16V
C111	1-104-542-11	s	CHIP FILM 0.0018uF 5% 50V
C112	1-163-145-00	s	CERAMIC 0.0015uF 10% 50V
C113	1-164-004-11	s	CERAMIC, CHIP 0.1uF 10% 25V
C114	1-104-913-11	s	TANTALUM, CHIP 10uF 20% 16V
C115	1-115-581-11	s	TANTALUM,CHIP 100uF 20% 16
C116	1-135-070-00	s	TANTALUM, CHIP 0.1uF 10% 35V
C117	1-135-179-21	s	TANTAL 2.2uF 10% 16V
C118	1-135-145-11	s	TANTALUM, CHIP 0.47uF 10% 35V
C119	1-164-004-11	s	CERAMIC, CHIP 0.1uF 10% 25V
C120	1-163-251-11	s	CERAMIC, CHIP 100PF 5% 50V
C121	1-115-581-11	s	TANTALUM,CHIP 100uF 20% 16
C122	1-104-913-11	s	TANTALUM, CHIP 10uF 20% 16V
C123	1-163-018-00	s	CERAMIC, CHIP 0.0056uF 5% 50V
C124	9-885-005-12	s	ELECT, CHIP 470uF 16V
C125	1-163-021-91	s	CERAMIC 0.01uF 10% 50V
C126	1-115-185-11	s	CERAMIC 0.033uF 10% 25V
C127	1-163-275-11	s	CERAMIC, CHIP 1000PF 5% 50V
C128	1-163-275-11	s	CERAMIC, CHIP 1000PF 5% 50V
C129	1-164-004-11	s	CERAMIC, CHIP 0.1uF 10% 25V
C130	1-164-004-11	s	CERAMIC, CHIP 0.1uF 10% 25V
C131	1-164-004-11	s	CERAMIC, CHIP 0.1uF 10% 25V
C151	1-104-913-11	s	TANTALUM, CHIP 10uF 20% 16V
C152	1-107-686-11	s	CHIP, TANTALUM 4.7uF 20% 16V
C153	1-163-235-11	s	CERAMIC, CHIP 22PF 5% 50V
C154	1-107-686-11	s	CHIP, TANTALUM 4.7uF 20% 16V
C155	1-164-004-11	s	CERAMIC, CHIP 0.1uF 10% 25V
C156	1-164-004-11	s	CERAMIC, CHIP 0.1uF 10% 25V
C157	1-163-235-11	s	CERAMIC, CHIP 22PF 5% 50V
C158	1-163-251-11	s	CERAMIC, CHIP 100PF 5% 50V
C159	1-164-004-11	s	CERAMIC, CHIP 0.1uF 10% 25V
C160	1-163-251-11	s	CERAMIC, CHIP 100PF 5% 50V
C161	9-885-005-13	s	CAPACITOR, PP 0.0015uF 100V
C162	9-885-005-13	s	CAPACITOR, PP 0.0015uF 100V
C163	1-163-235-11	s	CERAMIC, CHIP 22PF 5% 50V
C164	1-164-004-11	s	CERAMIC, CHIP 0.1uF 10% 25V
C171	1-115-419-11	s	CERAMIC 0.0033uF 10% 25V
C172	1-164-004-11	s	CERAMIC, CHIP 0.1uF 10% 25V
C175	1-163-235-11	s	CERAMIC, CHIP 22PF 5% 50V
C176	1-164-004-11	s	CERAMIC, CHIP 0.1uF 10% 25V
C182	1-163-135-00	s	CERAMIC 560PF 5% 50V
C183	1-163-251-11	s	CERAMIC, CHIP 100PF 5% 50V
C184	1-163-275-11	s	CERAMIC, CHIP 1000PF 5% 50V
C185	1-164-004-11	s	CERAMIC, CHIP 0.1uF 10% 25V
C186	1-163-235-11	s	CERAMIC, CHIP 22PF 5% 50V
C187	1-163-275-11	s	CERAMIC, CHIP 1000PF 5% 50V
CN102	1-564-704-11	s	CONNECTOR, 2P, MALE

(DF-58 Board)

Ref. No. or Q'ty	Part No.	SP	Description
D101	8-719-951-22	s	DIODE IMN10
D103	8-719-941-23	s	DIODE DA204U
D104	8-719-056-22	s	DIODE MA2S728-(K8).SO
IC101	△ 8-759-394-25	s	IC LA7858
IC102	8-759-075-70	s	IC TA75S393F
IC103	8-759-234-08	s	IC TA78L05F
IC104	8-759-394-30	s	IC GS4981IKA
IC105	8-759-242-78	s	IC TC7W02F
IC106	8-759-180-08	s	IC TC74HC4538AFS
IC107	8-759-058-62	s	IC TC7S08FU(TE85R)
IC108	8-759-082-61	s	IC TC4W53FU
IC109	8-759-180-08	s	IC TC74HC4538AFS
IC110	8-759-394-32	s	IC TC4427EOA
IC111	8-759-082-59	s	IC TC7W32FU
IC112	8-759-180-08	s	IC TC74HC4538AFS
IC113	8-759-058-64	s	IC TC7S32FU(TE85R)
IC114	8-759-082-55	s	IC TC7W00FU
IC115	8-759-180-08	s	IC TC74HC4538AFS
IC116	8-759-180-08	s	IC TC74HC4538AFS
Q101	8-729-802-80	s	TRANSISTOR 2SC3661
Q102	8-729-042-52	s	TRANSISTOR IMT1AT108
Q103	8-729-042-52	s	TRANSISTOR IMT1AT108
Q104	8-729-905-36	s	TRANSISTOR 2SC4081-S
Q105	8-729-402-84	s	TRANSISTOR XN4601
Q106	8-729-905-36	s	TRANSISTOR 2SC4081-S
Q107	8-729-905-36	s	TRANSISTOR 2SC4081-S
Q108	8-729-905-36	s	TRANSISTOR 2SC4081-S
Q109	8-729-036-19	s	TRANSISTOR IMB2A
Q110	8-729-425-41	s	TRANSISTOR 2SK1374
Q111	8-729-425-41	s	TRANSISTOR 2SK1374
Q112	8-729-026-53	s	TRANSISTOR 2SA1576A-T106-QR
Q113	8-729-042-52	s	TRANSISTOR IMT1AT108
Q114	8-729-028-91	s	TRANSISTOR DTA144EUA-T106
Q115	8-729-036-19	s	TRANSISTOR IMB2A
R101	1-216-833-11	s	METAL, CHIP 10K 5% 1/16W
R102	1-216-825-11	s	METAL, CHIP 2.2K 5% 1/16W
R103	1-216-837-11	s	METAL, CHIP 22K 5% 1/16W
R104	1-216-834-11	s	METAL, CHIP 12K 5% 1/16W
R105	1-216-832-11	s	METAL, CHIP 8.2K 5% 1/16W
R106	1-216-845-11	s	METAL, CHIP 100K 5% 1/16W
R107	1-216-832-11	s	METAL, CHIP 8.2K 5% 1/16W
R108	1-216-839-11	s	METAL, CHIP 33K 5% 1/16W
R109	1-218-345-11	s	METAL, CHIP 9.1K 5% 1/16W
R110	1-216-821-11	s	METAL, CHIP 1K 5% 1/16W
R111	1-218-294-11	s	METAL, CHIP 30K 5% 1/16W
R112	1-216-836-11	s	METAL, CHIP 18K 5% 1/16W
R114	1-218-830-11	s	METAL, CHIP 5.6K 5% 1/16W
R115	1-216-798-11	s	METAL, CHIP 12 5% 1/16W
R116	1-216-848-11	s	METAL, CHIP 180K 5% 1/16W
R117	1-216-846-11	s	METAL, CHIP 120K 5% 1/16W
R118	1-216-822-11	s	METAL, CHIP 1.2K 5% 1/16W
R119	1-216-845-11	s	METAL, CHIP 100K 5% 1/16W
R120	1-218-272-11	s	METAL, CHIP 5.1K 5% 1/16W
R121	1-218-272-11	s	METAL, CHIP 5.1K 5% 1/16W
R122	1-216-813-11	s	METAL, CHIP 220 5% 1/16W
R123	1-216-308-00	s	METAL, CHIP 4.7 5% 1/10W
R124	1-216-829-11	s	METAL, CHIP 4.7K 5% 1/16W

(DF-58 Board)

Ref. No. or Q'ty	Part No.	SP Description
R125	1-216-827-11	s METAL, CHIP 3.3K 5% 1/16W
R126	1-216-308-00	s METAL, CHIP 4.7 5% 1/10W
R127	1-216-308-00	s METAL, CHIP 4.7 5% 1/10W
R128	1-216-037-00	s METAL, CHIP 330 5% 1/10W
R129	1-216-801-11	s METAL, CHIP 22 5% 1/16W
R130	1-216-308-00	s METAL, CHIP 4.7 5% 1/10W
R131	1-216-821-11	s METAL, CHIP 1K 5% 1/16W
R132	1-216-816-11	s METAL, CHIP 330 5% 1/16W
R133	1-216-818-11	s METAL, CHIP 560 5% 1/16W
R134	1-218-272-11	s METAL, CHIP 5.1K 5% 1/16W
R135	1-216-836-11	s METAL, CHIP 18K 5% 1/16W
R136	1-216-829-11	s METAL, CHIP 4.7K 5% 1/16W
R137	1-216-832-11	s METAL, CHIP 8.2K 5% 1/16W
R138	1-216-825-11	s METAL, CHIP 2.2K 5% 1/16W
R139	1-218-331-11	s METAL, CHIP 51K 50% 1/16W
R140	1-216-835-11	s METAL, CHIP 15K 5% 1/16W
R141	1-216-833-11	s METAL, CHIP 10K 5% 1/16W
R142	1-216-836-11	s METAL, CHIP 18K 5% 1/16W
R143	1-218-272-11	s METAL, CHIP 5.1K 5% 1/16W
R144	1-216-816-11	s METAL, CHIP 330 5% 1/16W
R145	1-216-816-11	s METAL, CHIP 330 5% 1/16W
R146	1-216-816-11	s METAL, CHIP 330 5% 1/16W
R147	1-216-816-11	s METAL, CHIP 330 5% 1/16W
R148	1-216-841-11	s METAL, CHIP 47K 5% 1/16W
R149	1-216-841-11	s METAL, CHIP 47K 5% 1/16W
R151	1-216-841-11	s METAL, CHIP 47K 5% 1/16W
R152	1-216-825-11	s METAL, CHIP 2.2K 5% 1/16W
R153	1-216-825-11	s METAL, CHIP 2.2K 5% 1/16W
R154	1-216-833-11	s METAL, CHIP 10K 5% 1/16W
R155	1-216-851-11	s METAL, CHIP 330K 5% 1/16W
R156	1-216-813-11	s METAL, CHIP 220 5% 1/16W
R157	1-216-833-11	s METAL, CHIP 10K 5% 1/16W
R158	1-216-993-11	s METAL, CHIP 2.4K 5% 1/16W
R159	1-216-827-11	s METAL, CHIP 3.3K 5% 1/16W
R160	1-216-827-11	s METAL, CHIP 3.3K 5% 1/16W
R161	1-216-821-11	s METAL, CHIP 1K 5% 1/16W
R162	1-216-826-11	s METAL, CHIP 2.7K 5% 1/16W
R163	1-216-994-11	s METAL, CHIP 13K 5% 1/16W
R164	1-216-813-11	s METAL, CHIP 220 5% 1/16W
R165	1-216-801-11	s METAL, CHIP 22 5% 1/16W
R166	1-216-816-11	s METAL, CHIP 330 5% 1/16W
R167	1-216-816-11	s METAL, CHIP 330 5% 1/16W
R168	1-216-816-11	s METAL, CHIP 330 5% 1/16W
R169	1-216-816-11	s METAL, CHIP 330 5% 1/16W
R171	1-216-834-11	s METAL, CHIP 12K 5% 1/16W
R172	1-218-292-11	s METAL, CHIP 20K 5% 1/16W
R173	1-216-839-11	s METAL, CHIP 33K 5% 1/16W
R174	1-216-994-11	s METAL, CHIP 13K 5% 1/16W
R175	1-220-372-11	s METAL, CHIP 200K 5% 1/16W
	1-216-848-11	s METAL, CHIP 180K 5% 1/16W
	1-216-861-11	s METAL, CHIP 220K 5% 1/16W
R176	1-216-827-11	s METAL, CHIP 3.3K 5% 1/16W
R178	1-216-801-11	s METAL, CHIP 22 5% 1/16W
R179	1-216-818-11	s METAL, CHIP 560 5% 1/16W
R180	1-216-801-11	s METAL, CHIP 22 5% 1/16W
R181	1-218-830-11	s METAL, CHIP 5.6K 5% 1/16W
R182	1-218-830-11	s METAL, CHIP 5.6K 5% 1/16W
R183	1-218-271-11	s METAL, CHIP 2K 5% 1/16W
R184	1-216-809-11	s METAL, CHIP 100 5% 1/16W
R185	1-216-809-11	s METAL, CHIP 100 5% 1/16W

(DF-58 Board)

Ref. No. or Q'ty	Part No.	SP Description
R186	1-216-841-11	s METAL, CHIP 47K 5% 1/16W
R187	1-216-821-11	s METAL, CHIP 1K 5% 1/16W
R188	1-216-821-11	s METAL, CHIP 1K 5% 1/16W
R189	1-216-821-11	s METAL, CHIP 1K 5% 1/16W
R190	1-216-850-11	s METAL, CHIP 270K 5% 1/16W
	1-216-849-11	s METAL, CHIP 220K 5% 1/16W
R191	1-216-850-11	s METAL, CHIP 270K 5% 1/16W
	1-216-849-11	s METAL, CHIP 220K 5% 1/16W
RV101	9-885-005-14	s RES, ADJ METAL 5K
RV102	9-885-005-09	s RES, ADJ METAL 4.7K
RV103	9-885-005-09	s RES, ADJ METAL 4.7K
RV104	9-885-005-09	s RES, ADJ METAL 4.7K
RV105	9-885-005-15	s RES, ADJ METAL 220K
RV106	9-885-005-16	s RES, ADJ METAL 200
RV107	9-885-005-14	s RES, ADJ METAL 5K
RV108	9-885-005-14	s RES, ADJ METAL 5K
RV109	9-885-005-09	s RES, ADJ METAL 4.7K
RV110	9-885-005-14	s RES, ADJ METAL 5K
RV111	9-885-005-09	s RES, ADJ METAL 4.7K
RV112	9-885-005-17	s RES, ADJ METAL 50K
RV113	9-885-005-09	s RES, ADJ METAL 4.7K
RV114	9-885-005-10	s RES, ADJ METAL 47K
RV115	9-885-005-18	s RES, ADJ METAL 470
RV116	9-885-005-19	s RES, ADJ METAL 1K
RV117	9-885-005-19	s RES, ADJ METAL 1K
RV118	9-885-005-09	s RES, ADJ METAL 4.7K
RV119	9-885-005-20	s RES, ADJ METAL 500
RV120	9-885-005-20	s RES, ADJ METAL 500
RV121	9-885-005-14	s RES, ADJ METAL 5K
RV122	9-885-005-14	s RES, ADJ METAL 5K

 LP-105 Board

Ref. No. or Q'ty	Part No.	SP Description
1pc	A-8315-579-A	o MOUNTED CIRCUIT BOARD, LP-105
CN21	1-565-651-11	o PIN, CONNECTOR 8P
D1	8-729-026-39	s TRANSISTOR 2SA933AS-QT
D2	8-719-026-40	s DIODE CL-150UR-CD-T
D3	8-719-987-43	s DIODE CL-150PG-CD
D4	8-719-026-16	s DIODE CL-150D-CD-T
D5	8-719-026-40	s DIODE CL-150UR-CD-T
D6	8-719-026-16	s DIODE CL-150D-CD-T

 VDA-41 Board

Ref. No. or Q'ty	Part No.	SP Description
1pc	1-761-339-11	o MOUNTED CIRCUIT BOARD, VDA-41
C261	1-110-497-11	s CERAMIC, CHIP 0.1uF 20% 100V
C262	1-163-259-91	s CERAMIC 220PF 5% 50V
C263	1-164-004-11	s CERAMIC, CHIP 0.1uF 10% 25V
C264	1-110-497-11	s CERAMIC, CHIP 0.1uF 20% 100V
C265	1-164-004-11	s CERAMIC, CHIP 0.1uF 10% 25V
D261	8-719-984-56	s DIODE HZK2ALL
D262	8-719-052-18	s DIODE RLS245TE-11
Q261	8-729-036-39	s TRANSISTOR 2SC4104
Q262	8-729-036-38	s TRANSISTOR 2SC4080
Q263	8-729-036-39	s TRANSISTOR 2SC4104
Q264	8-729-036-40	s TRANSISTOR 2SA1580
Q265	8-729-036-39	s TRANSISTOR 2SC4104
Q266	8-729-036-40	s TRANSISTOR 2SA1580
Q267	8-729-036-39	s TRANSISTOR 2SC4104
R261	1-218-289-11	s METAL, CHIP 510 5% 1/16W
R262	1-202-923-91	s METAL, CHIP 130 5% 1/16W
R263	9-885-005-00	s METAL, CHIP 3.9K
R264	1-216-809-11	s METAL, CHIP 100 5% 1/16W
R265	1-216-833-11	s METAL, CHIP 10K 5% 1/16W
R266	1-216-809-11	s METAL, CHIP 100 5% 1/16W
R267	1-216-834-11	s METAL, CHIP 12K 5% 1/16W
R268	1-216-809-11	s METAL, CHIP 100 5% 1/16W
R269	1-216-834-11	s METAL, CHIP 12K 5% 1/16W
R270	1-216-809-11	s METAL, CHIP 100 5% 1/16W
R271	1-216-809-11	s METAL, CHIP 100 5% 1/16W
R272	1-216-803-11	s METAL, CHIP 33 5% 1/16W
R273	1-216-803-11	s METAL, CHIP 33 5% 1/16W
R274	1-218-179-11	s RES, CHIP 10M 5% 1/10W
R275	1-218-289-11	s METAL, CHIP 510 5% 1/16W
R276	1-218-273-11	s METAL, CHIP 510K 5% 1/16W
R277	1-216-033-00	s METAL, CHIP 220 5% 1/10W

VF-70 Board

Ref. No. or Q'ty	Part No.	SP	Description
1pc	1-761-333-11	o	MOUNTED CIRCUIT BOARD, VF-70
C301	1-164-004-11	s	CERAMIC, CHIP 0.1uF 10% 25V
C302	1-164-004-11	s	CERAMIC, CHIP 0.1uF 10% 25V
C303	1-164-004-11	s	CERAMIC, CHIP 0.1uF 10% 25V
C304	1-164-004-11	s	CERAMIC, CHIP 0.1uF 10% 25V
C305	1-164-004-11	s	CERAMIC, CHIP 0.1uF 10% 25V
C306	1-135-160-21	s	CHIP, TANTALUM 15uF 10% 16V
C307	1-107-686-11	s	CHIP, TANTALUM 4.7uF 20% 16V
C308	1-164-001-11	s	CERAMIC 150PF 5% 50V
C309	1-104-913-11	s	TANTALUM, CHIP 10uF 20% 16V
C310	1-164-001-11	s	CERAMIC 150PF 5% 50V
C311	1-164-004-11	s	CERAMIC, CHIP 0.1uF 10% 25V
C312	1-164-004-11	s	CERAMIC, CHIP 0.1uF 10% 25V
C401	9-885-005-02	s	ELECT 220uF 25V
C402	1-135-091-00	s	TANTALUM, CHIP 1uF 20% 16V
C403	1-164-686-91	s	CERAMIC 0.0015 5% 50V
C404	1-104-919-11	s	TANTALUM, CHIP 10uF 20% 25V
C405	1-163-275-91	s	CERAMIC 0.001 5% 50V
C406	1-164-001-11	s	CERAMIC 150PF 5% 50V
C407	9-885-005-03	s	CAPACITOR, OS 150uF 16V
C408	1-104-913-11	s	TANTALUM, CHIP 10uF 20% 16V
C409	1-107-686-11	s	CHIP, TANTALUM 4.7uF 20% 16V
C410	1-163-251-91	s	CERAMIC 0.0001 5% 50V
C411	1-164-686-91	s	CERAMIC 0.0015 5% 50V
C412	1-164-686-91	s	CERAMIC 0.0015 5% 50V
C413	1-163-275-91	s	CERAMIC 0.001 5% 50V
C414	1-164-001-11	s	CERAMIC 150PF 5% 50V
C415	9-885-005-03	s	CAPACITOR, OS 150uF 16V
C501	1-163-251-91	s	CERAMIC 0.0001 5% 50V
C502	1-164-001-11	s	CERAMIC 150PF 5% 50V
C503	1-164-001-11	s	CERAMIC 150PF 5% 50V
C504	1-135-179-21	s	TANTALUM 2.2uF 10% 16V
C505	1-107-686-11	s	CHIP, TANTALUM 4.7uF 20% 16V
C506	1-164-001-11	s	CERAMIC 150PF 5% 50V
C507	1-164-001-11	s	CERAMIC 150PF 5% 50V
C508	1-164-686-91	s	CERAMIC 0.0015 5% 50V
C509	1-164-691-11	s	CERAMIC 0.0024uF 5% 50V
C510	△ 9-885-005-04	s	CAPACITOR, PP 6800P 250V
C511	△ 9-885-005-06	s	CAPACITOR, PP 2200P 250V
C512	1-164-686-91	s	CERAMIC 0.0015 5% 50V
C513	1-104-913-11	s	TANTALUM, CHIP 10uF 20% 16V
C514	1-164-001-11	s	CERAMIC 150PF 5% 50V
C515	1-164-346-11	s	CERAMIC 1uF 16V
C516	9-885-005-08	s	CAPACITOR, ELECT 470uF
C517	1-115-581-11	s	TANTALUM, CHIP 100uF 20% 16V
C518	1-110-497-11	s	CHIP CERAMIC 1uF 20% 100V
C519	1-110-497-11	s	CHIP CERAMIC 1uF 20% 100V
C520	1-110-497-11	s	CHIP CERAMIC 1uF 20% 100V
C521	1-163-018-00	s	CERAMIC, CHIP 0.0056uF 5% 50V
CN1	1-580-539-11	o	PIN, CONNECTOR (PC BOARD) 20P
CN501	1-564-705-11	s	CONNECTOR, 3P, MALE
CN502	1-564-706-11	o	PIN HEADER, STRAIGHT 4P
CN101A	1-750-710-11	o	CONNECTOR, BOARD TO BOARD
CN201A	1-569-528-11	s	HOUSING 12P
D301	8-719-941-23	s	DIODE DA204U
D302	8-719-941-23	s	DIODE DA204U
D303	8-719-056-80	s	DIODE UDZ5.1B
D304	8-719-056-80	s	DIODE UDZ5.1B
D305	8-719-056-80	s	DIODE UDZ5.1B

(VF-70 Board)

Ref. No. or Q'ty	Part No.	SP	Description
D306	8-719-056-80	s	DIODE UDZ5.1B
D307	8-719-056-80	s	DIODE UDZ5.1B
D401	8-719-989-76	s	DIODE SC802-04
D402	8-719-989-76	s	DIODE SC802-04
D501	8-719-941-23	s	DIODE DA204U
D502	8-719-941-23	s	DIODE DA204U
D503	8-719-941-23	s	DIODE DA204U
D504	8-719-941-86	s	DIODE DAN202U
D505	8-719-941-23	s	DIODE DA204U
D506	8-719-941-86	s	DIODE DAN202U
D507	8-759-394-26	s	IC LM4041EIM3-1.2
FBT1	△ 1-453-243-11	s	TRANSFORMER, FLYBACK
HLC1	△ 1-416-387-11	s	COIL, LINEARITY
IC301	8-759-990-61	s	IC PCF8574T
IC302	8-759-990-61	s	IC PCF8574T
IC303	8-759-394-34	s	IC BR24C02F
IC304	8-759-939-51	s	IC BA225F
IC305	8-759-082-59	s	IC TC7W32FU
IC306	8-759-209-57	s	IC TC4S69F
IC401	8-759-485-77	s	IC BA9743AFV-E2
IC501	8-759-394-31	s	IC TC4426EOA
IC502	8-759-060-00	s	IC BA10324AF
IC503	8-759-075-66	s	IC TA75S01F
IC504	8-759-050-14	s	IC SN74HC175APW-E05
L401	1-411-877-11	s	COIL, CHOKE 56uH
L402	1-411-877-11	s	COIL, CHOKE 56uH
L403	1-411-227-11	s	COIL, CHOKE 100uH
LED301	8-719-989-53	s	DIODE CL-200HR-C-TSL
Q301	8-729-036-19	s	TRANSISTOR IMB2A
Q302	8-729-036-19	s	TRANSISTOR IMB2A
Q303	8-729-036-48	s	TRANSISTOR IMH2A
Q304	8-729-036-48	s	TRANSISTOR IMH2A
Q305	8-729-036-19	s	TRANSISTOR IMB2A
Q306	8-729-036-20	s	TRANSISTOR IMH3A
Q401	8-729-905-36	s	TRANSISTOR 2SC4081-S
Q402	8-729-040-75	s	TRANSISTOR S14953DY-T1
Q403	8-729-402-84	s	TRANSISTOR XN4601
Q404	8-729-402-84	s	TRANSISTOR XN4601
Q501	9-885-005-01	s	TRANSISTOR 2SK2534
Q502	8-729-037-55	s	TRANSISTOR 2SK1826(TE85L)
Q503	8-729-035-20	s	TRANSISTOR 2SK1920
R301	1-216-827-11	s	METAL, CHIP 3.3K 5% 1/16W
R302	1-216-827-11	s	METAL, CHIP 3.3K 5% 1/16W
R303	1-218-288-11	s	METAL 300 5% 1/16W
R304	1-218-288-11	s	METAL 300 5% 1/16W
R305	1-216-821-11	s	METAL, CHIP 1K 5% 1/16W
R306	1-216-803-11	s	METAL, CHIP 33 5% 1/16W
R307	1-216-841-11	s	METAL 47K 5% 1/16W
R308	1-216-837-11	s	CHIP, METAL 22K 5% 1/16W
R309	1-216-855-11	s	METAL, CHIP 680K 5% 1/16W
R310	1-216-842-11	s	METAL, CHIP 56K 5% 1/16W
R312	1-216-818-11	s	METAL, CHIP 560 5% 1/16W
R313	1-216-832-11	s	METAL, CHIP 8.2K 5% 1/16W
R314	1-216-821-11	s	METAL, CHIP 1K 5% 1/16W
R315	1-216-821-11	s	METAL, CHIP 1K 5% 1/16W
R316	1-216-821-11	s	METAL, CHIP 1K 5% 1/16W

(VF-70 Board)

Ref. No. or Q'ty	Part No.	SP Description
R317	1-216-821-11	s METAL, CHIP 1K 5% 1/16W
R318	1-216-821-11	s METAL, CHIP 1K 5% 1/16W
R319	1-216-827-11	s METAL, CHIP 3.3K 5% 1/16W
R320	1-216-821-11	s METAL, CHIP 1K 5% 1/16W
R321	1-216-825-11	s METAL, CHIP 2.2K 5% 1/16W
R322	1-216-825-11	s METAL, CHIP 2.2K 5% 1/16W
R323	1-216-825-11	s METAL, CHIP 2.2K 5% 1/16W
R401	1-216-833-11	s METAL, CHIP 10K 5% 1/16W
R402	1-216-821-11	s METAL, CHIP 1K 5% 1/16W
R403	1-216-049-91	s METAL 1K 5% 1/10W
R404	1-216-821-11	s METAL, CHIP 1K 5% 1/16W
R405	1-216-793-11	s METAL 4.7 5% 1/16W
R406	1-216-816-11	s CHIP, METAL 390 5% 1/16W
R407	1-218-745-11	s METAL, CHIP 160K 5% 1/16W
R408	1-216-837-11	s CHIP, METAL 22K 5% 1/16W
R409	1-216-839-11	s METAL, CHIP 33K 5% 1/16W
R410	1-216-839-11	s METAL, CHIP 33K 5% 1/16W
R411	1-216-839-11	s METAL, CHIP 33K 5% 1/16W
R412	1-216-827-11	s METAL, CHIP 3.3K 5% 1/16W
R413	1-216-833-11	s METAL, CHIP 10K 5% 1/16W
R414	1-216-834-11	s METAL, CHIP 12K 5% 1/16W
R415	1-216-832-11	s METAL, CHIP 8.2K 5% 1/16W
R416	1-216-837-11	s CHIP, METAL 22K 5% 1/16W
R417	1-216-049-91	s METAL 1K 5% 1/10W
R418	1-216-821-11	s METAL, CHIP 1K 5% 1/16W
R419	1-216-793-11	s METAL 4.7 5% 1/16W
R420	1-216-816-11	s CHIP, METAL 390 5% 1/16W
R421	1-218-295-11	s METAL 43K 5% 1/16W
R422	1-216-833-11	s METAL, CHIP 10K 5% 1/16W
R501	1-216-827-11	s METAL, CHIP 3.3K 5% 1/16W
R502	1-216-833-11	s METAL, CHIP 10K 5% 1/16W
R503	1-216-793-11	s METAL 4.7 5% 1/16W
R504	1-218-331-11	s CHIP, METAL 51K 5% 1/16W
R505	1-218-272-11	s METAL, CHIP 5.1K 5% 1/16W
R506	1-218-890-11	s CHIP, METAL 62K 5% 1/16W
R507	1-216-839-11	s METAL, CHIP 33K 5% 1/16W
R508	1-216-839-11	s METAL, CHIP 33K 5% 1/16W
R509	△ 1-218-725-11	s CHIP, METAL 24K 5% 1/16W
R510	△ 1-218-890-11	s CHIP, METAL 62K 5% 1/16W
R511	1-216-833-11	s METAL, CHIP 10K 5% 1/16W
R512	1-216-827-11	s METAL, CHIP 3.3K 5% 1/16W
R513	1-216-827-11	s METAL, CHIP 3.3K 5% 1/16W
R514	1-216-827-11	s METAL, CHIP 3.3K 5% 1/16W
R515	1-216-793-11	s METAL 4.7 5% 1/16W
R516	1-216-809-11	s METAL, CHIP 100 5% 1/16W
R517	1-216-833-11	s METAL, CHIP 10K 5% 1/16W
R518	1-216-838-11	s METAL, CHIP 27K 5% 1/16W
R519	1-216-803-11	s RES, CHIP 3.3M 5% 1/4W
R520	1-216-803-11	s RES, CHIP 3.3M 5% 1/4W
R521	1-216-803-11	s RES, CHIP 3.3M 5% 1/4W
R522	1-216-033-00	s CHIP, METAL 220 5% 1/10W
R527	1-216-845-11	s METAL, CHIP 100K 5% 1/16W
R528	1-216-845-11	s METAL, CHIP 100K 5% 1/16W
R529	1-216-837-11	s CHIP, METAL 22K 5% 1/16W
R530	1-216-837-11	s CHIP, METAL 22K 5% 1/16W
R531	1-216-809-11	s METAL, CHIP 100 5% 1/16W
R532	1-216-809-11	s METAL, CHIP 100 5% 1/16W
R533	1-216-809-11	s METAL, CHIP 100 5% 1/16W
RV401	9-885-005-09	s RES, ADJ METAL 4.7K

(VF-70 Board)

Ref. No. or Q'ty	Part No.	SP Description
RV501	9-885-005-10	s RES, ADJ METAL 47K
S301	1-762-019-11	s SWITCH, TOGGLE
S302	1-762-020-11	s SWITCH, TOGGLE
S303	1-762-489-11	s SWITCH, TOGGLE

 VR-266 Board

Ref. No. or Q'ty	Part No.	SP	Description
1pc	1-761-335-11	o	MOUNTED CIRCUIT BOARD, VR-266
2pcs	3-697-153-01	o	PLATE,GROUND(2)
C201	1-115-581-11	s	TANTALUM,CHIP 100uF 20% 16
C202	1-115-581-11	s	TANTALUM,CHIP 100uF 20% 16
C203	1-115-581-11	s	TANTALUM,CHIP 100uF 20% 16
C204	1-164-004-11	s	CERAMIC, CHIP 0.1uF 10% 25V
C205	1-164-346-11	s	CERAMIC 1uF 16V
C206	1-104-913-11	s	TANTALUM, CHIP 10uF 20% 16V
C207	1-107-686-11	s	CHIP, TANTALUM 4.7uF 20% 16V
C208	1-163-021-91	s	CERAMIC, CHIP 0.01uF 10% 50V
C209	1-164-004-11	s	CERAMIC, CHIP 0.1uF 10% 25V
C211	1-164-004-11	s	CERAMIC, CHIP 0.1uF 10% 25V
C212	1-164-004-11	s	CERAMIC, CHIP 0.1uF 10% 25V
C213	1-163-235-11	s	CERAMIC, CHIP 22PF 5% 50V
C214	1-164-004-11	s	CERAMIC, CHIP 0.1uF 10% 25V
C215	1-164-004-11	s	CERAMIC, CHIP 0.1uF 10% 25V
C216	1-163-275-11	s	CERAMIC, CHIP 0.001uF 10% 50V
C217	1-107-686-11	s	CHIP, TANTALUM 4.7uF 20% 16V
C218	1-164-004-11	s	CERAMIC, CHIP 0.1uF 10% 25V
C219	1-107-688-11	s	CHIP,TANTALUM 1.5uF 20% 25V
C220	1-164-691-11	s	CERAMIC 0.0024uF 5% 50V
C221	1-164-004-11	s	CERAMIC, CHIP 0.1uF 10% 25V
C222	1-164-004-11	s	CERAMIC, CHIP 0.1uF 10% 25V
C224	1-110-497-11	s	CHIP CERAMIC 1uF 20% 100V
C225	9-885-005-22	s	ELECT 4.7uF 100V
CN201B	1-569-528-11	s	HOUSING 12P
CN202	9-885-005-21	s	PIN HEADER
CN203	9-885-005-21	s	PIN HEADER
D201	8-719-941-86	s	DIODE DAN202U
D202	9-885-005-23	s	DIODE UDZ15B
D203	9-885-005-24	s	DIODE UDZ5.1B
DL201	1-411-876-11	s	DELAY LINE
IC201	8-759-058-50	s	IC XRA10324AF
IC202	8-759-391-22	s	IC CA3094M
IC203	8-759-394-29	s	IC AD8011AR
IC204	8-759-395-40	s	IC HPAL1351B
IC205	8-759-391-21	s	IC DG613-DY
L201	1-412-066-21	s	INDUCTOR CHIP 220UH
LED201	8-719-989-53	s	DIODE CL-200HR-C-TSL
LED202	8-719-989-53	s	DIODE CL-200HR-C-TSL
Q201	8-729-036-40	s	TRANSISTOR 2SA1580
Q202	8-729-036-39	s	TRANSISTOR 2SC4104
Q203	8-729-036-39	s	TRANSISTOR 2SC4104
Q204	8-729-927-87	s	TRANSISTOR 2SA1579RR
Q205	8-729-038-81	s	TRANSISTOR 2SC4102-T106
Q206	8-729-802-80	s	TRANSISTOR 2SC3661
Q207	9-885-005-25	s	TRANSISTOR IMT1A
R201	1-216-839-11	s	METAL, CHIP 33K 5% 1/16W
R203	1-216-023-00	s	CHIP, METAL 82 5% 1/10W
R204	1-216-812-11	s	METAL, CHIP 180 5% 1/16W
R205	1-218-331-11	s	CHIP, METAL 51K 5% 1/16W
R206	1-216-827-11	s	METAL, CHIP 3.3K 5% 1/16W
R207	1-216-833-11	s	METAL, CHIP 10K 5% 1/16W
R209	1-218-272-11	s	METAL, CHIP 5.1K 5% 1/16W
R210	1-218-272-11	s	METAL, CHIP 5.1K 5% 1/16W
R211	1-216-833-11	s	METAL, CHIP 10K 5% 1/16W

(VR-266 Board)

Ref. No. or Q'ty	Part No.	SP	Description
R212	1-216-809-11	s	METAL, CHIP 100 5% 1/16W
R213	1-216-821-11	s	METAL, CHIP 1K 5% 1/16W
R214	1-216-821-11	s	METAL, CHIP 1K 5% 1/16W
R215	1-216-827-11	s	METAL, CHIP 3.3K 5% 1/16W
R216	1-220-151-11	s	METAL, CHIP 51 5% 1/16W
R217	1-216-821-11	s	METAL, CHIP 1K 5% 1/16W
R218	1-216-811-11	s	METAL, CHIP 150 5% 1/16W
R219	1-216-811-11	s	METAL, CHIP 150 5% 1/16W
R220	1-216-821-11	s	METAL, CHIP 1K 5% 1/16W
R221	1-216-821-11	s	METAL, CHIP 1K 5% 1/16W
R222	1-218-269-11	s	METAL, CHIP 360 5% 1/16W
R223	1-218-269-11	s	METAL, CHIP 360 5% 1/16W
R224	1-216-821-11	s	METAL, CHIP 1K 5% 1/16W
R225	1-216-820-91	s	RES, CHIP 820 5% 1/16W
R226	1-216-834-11	s	METAL, CHIP 12K 5% 1/16W
R227	1-216-833-11	s	METAL, CHIP 10K 5% 1/16W
R228	1-220-151-11	s	METAL, CHIP 51 5% 1/16W
R229	1-216-813-11	s	METAL, CHIP 220 5% 1/16W
R230	1-216-809-11	s	METAL, CHIP 100 5% 1/16W
R231	1-216-809-11	s	METAL, CHIP 100 5% 1/16W
R232	1-216-837-11	s	CHIP, METAL 22K 5% 1/16W
R234	1-216-813-11	s	METAL, CHIP 220 5% 1/16W
R235	1-218-292-11	s	METAL, CHIP 20K 5% 1/10W
R236	1-218-292-11	s	METAL, CHIP 20K 5% 1/10W
R237	1-216-844-11	s	CHIP, METAL 82K 5% 1/16W
R238	1-216-821-11	s	METAL, CHIP 1K 5% 1/16W
R239	1-216-813-11	s	METAL, CHIP 220 5% 1/16W
R240	1-216-833-11	s	METAL, CHIP 10K 5% 1/16W
R241	1-216-821-11	s	METAL, CHIP 1K 5% 1/16W
R242	1-220-151-11	s	METAL, CHIP 51 5% 1/16W
R243	1-216-841-11	s	METAL 47K 5% 1/16W
R244	1-218-272-11	s	METAL, CHIP 5.1K 5% 1/16W
R246	1-216-833-11	s	METAL, CHIP 10K 5% 1/16W
R247	1-216-833-11	s	METAL, CHIP 10K 5% 1/16W
R248	1-216-845-11	s	METAL, CHIP 100K 5% 1/16W
R249	1-218-331-11	s	CHIP, METAL 51K 5% 1/16W
R250	1-218-331-11	s	CHIP, METAL 51K 5% 1/16W
R251	1-218-272-11	s	METAL, CHIP 5.1K 5% 1/16W
R252	1-216-817-11	s	CHIP, METAL 470 5% 1/16W
R253	1-216-809-11	s	METAL, CHIP 100 5% 1/16W
R254	1-202-926-11	s	CHIP, METAL 36K 5% 1/16W
R255	1-216-841-11	s	METAL 47K 5% 1/16W
R256	1-216-815-11	s	METAL, CHIP 330 5% 1/16W
R257	1-216-815-11	s	METAL, CHIP 330 5% 1/16W
R258	1-216-815-11	s	METAL, CHIP 330 5% 1/16W
R259	1-216-815-11	s	METAL, CHIP 330 5% 1/16W
RV201	1-238-290-11	s	CARBON, VAR 1K
RV202	9-885-005-09	s	RES, ADJ METAL 4.7K
RV203	9-885-005-18	s	RES, ADJ METAL 470
RV204	1-238-290-11	s	CARBON, VAR 1K
RV205	9-885-005-15	s	RES, ADJ METAL 220K
RV206	1-238-293-11	s	CARBON, VAR 10K
RV207	9-885-005-09	s	RES, ADJ METAL 4.7K
RV208	9-885-005-09	s	RES, ADJ METAL 4.7K

Frame

Ref. No. or Q'ty	Part No.	SP Description
1pc	Δ 1-251-636-11	s CRT ASSY, 2inch HD
1pc	1-777-131-11	s CORD, CONNECTION(VF)

3-3. Supplied Accessories

Ref. No. or Q'ty	Part No.	SP Description
1pc	3-179-882-01	o SPACER, MICROPHONE(21 mm dia.)
1pc	3-680-582-01	o HOLDER (B), MICROPHONE(19 mm dia.)

3-4. Tools and Fixtures

Part No.	SP Description
J-6029-140-B	o PATTERN BOX PTB-500
J-6395-050-A	o VF EXTENSION HARNESS
J-6395-320-A	o RESOLUTION CHART(16:9)

Section 4

Semiconductor Pin Assignments

The following describes the semiconductor types used in this unit.

For semiconductors marked with page numbers in the index, refer to the corresponding pages in this section.

However, in some cases incompatible types are also listed, therefore, when a part is to be replaced, also refer to the Spare Parts section.

In addition, for semiconductors with ID Nos., refer to the separate CD-ROM titled “Semiconductor Pin Assignments” (Sony Part No. 9-968-546-xx) that allows searching for parts by semiconductor type or ID No.

The semiconductors in the manual or on the CD-ROM are listed by equivalent types. Thus the external view or the index mark indication may differ from the actual type.

Pin assignments and block diagrams are based on the IC manufacturer’s data book.

本機に使用されている半導体型名の一覧を下記に示します。索引中、ページが記載されている半導体は、本章の該当ページを参照してください。ただし、互換性のない型名を併記している場合がありますので、部品を交換するときは、Spare Partsの章を参照してください。

また、ID番号が記載されている半導体は、別途発行の“Semiconductor Pin Assignments” CD-ROM版 (ソニー部品番号：9-968-546-xx)を参照してください。半導体型名またはID番号から検索ができます。

マニュアルまたはCD-ROMに掲載されている半導体は、それぞれの機能を等価的に表わしたものです。

外観やインデックスマークの表示方法が実物と異なる場合があります。

ピン配置およびブロック図はICメーカーのデータブックに従いました。

DIODE	Page or ID No.	TRANSISTOR	Page or ID No.
DA204U	DC001-01	2SA1576A-T106-QR	TC001-01
DA204UT106	DC001-01	2SA1576A-T106-R	TC001-01
DAN202U	DC001-03	2SA1579RR	TC001-01
DAN202UT106	DC001-03	2SA1580	TC001-01
DTZ5.1B	DC008-04	2SA933AS-QT	TR008-02
		2SA933AS-RT	TR008-02
HZK2ALL	DC008-04	2SC3661	TC001-02
HZK2ALLTL	DC008-04	2SC4080	TC002-02
		2SC4081-S	TC001-02
IMN10	DC005-01	2SC4102-T106	TC001-02
		2SC4102T106	TC001-02
MA2S728-(K8).SO	DC008-02	2SC4104	TC001-02
RD15UJN-T1	DC008-04	2SK1374	TC001-07
RLS245TE-11	DC006-01	2SK1826(TE85L)	TC001-07
		2SK1920-TL	TC010-01
SC802-04	DC008-02	2SK2534	4-2
SC802-04-TE12RA	DC008-02		
UDZ-TE-17-15B	DC008-04	DTA144EUA-T106	TC001-04
UDZ-TE-17-5.1B	DC008-04	IMB2A	TC005-07
		IMH2A	TC005-14
		IMH3A	TC005-12
		IMT1AT108	TC006-10
		SI4953DY-T1	TC012-02
		XN4601	TC006-06
		XN4601-TX	TC006-06
LED	Page or ID No.		
CL-150D-CD	LC001-01		
CL-150D-CD-T	LC001-01		
CL-150PG-CD	LC001-01		
CL-150PG-CD-T	LC001-01		
CL-150UR-CD-T	LC001-01		

IC	Page or ID No.
AD8011AR	AD8011AR
BA10324AF	XRA10324AF
BA225F-T1	BA225F
BA9743AFV-E2	4-3
BR24C02F	BR24C02F
CA3094M	4-3
DG613-DY	4-3
GS4981IKA	GS4981CTA
HFA1135IB	4-3
LA7858	LA7858
LM4041EIM3-1.2	4-3
PCF8574T	PCF8574T
SN74HC175APW-E05	TC74HC175P
TA75S01F	TA75S01F
TA75S393F	TA75S393F
TA75S393F-TE85R	TA75S393F
TA78L05F	NJM78L12UA
TA78L05F-TE12L	NJM78L12UA
TC4426EOA	TC4426EOA
TC4427EOA	TC4427EOA
TC4S69F	TC7S04F
TC4S69F(TE85R)	TC7S04F
TC4W53FU	TC4W53FU
TC4W53FU(TE12R)	TC4W53FU
TC74HC4538AFS	MC74HC4538N
TC74HC4538AFS-EL	MC74HC4538N
TC74HC4538AFT(EL)	MC74HC4538N
TC7S08FU(TE85R)	TC7S08F
TC7S32FU(TE85R)	TC7S32F
TC7W00FU	TC7W00F
TC7W00FU(TE12R)	TC7W00F
TC7W02F	TC7W02F
TC7W02FU(TE12R)	TC7W02F
TC7W08FU	TC7W08F
TC7W08FU(TE12R)	TC7W08F
TC7W32FU	TC7W32FU

TRANSISTOR

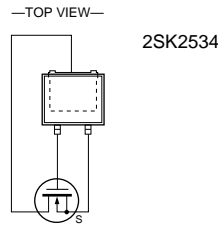

IC

BA9743AFV-E2 (ROHM)

2-CH SWITCHING REGULATOR CONTROLLER
—TOP VIEW—

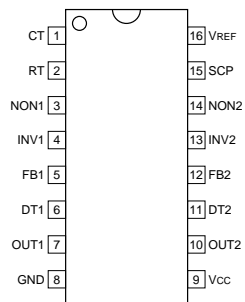

INPUTS

- CT : EXTERNAL TIMING CAPACITANCE
- DT1 : OUTPUT 1 DEAD TIME/SOFT START SETTING
- DT2 : OUTPUT 2 DEAD TIME/SOFT START SETTING
- INV1 : NEGATIVE INPUT FOR ERROR AMPLIFIER 1
- INV2 : NEGATIVE INPUT FOR ERROR AMPLIFIER 2
- NON1 : POSITIVE INPUT FOR ERROR AMPLIFIER 1
- NON2 : POSITIVE INPUT FOR ERROR AMPLIFIER 2
- RT : EXTERNAL TIMING RESISTANCE
- SCP : TIMER LATCH SETTING

OUTPUTS

- FB1 : OUTPUT FOR ERROR AMPLIFIER 1
- FB2 : OUTPUT FOR ERROR AMPLIFIER 2
- OUT1, OUT2 : OUTPUT 1, OUTPUT 2
- VREF : REFERENCE VOLTAGE (2.505 V) OUTPUT

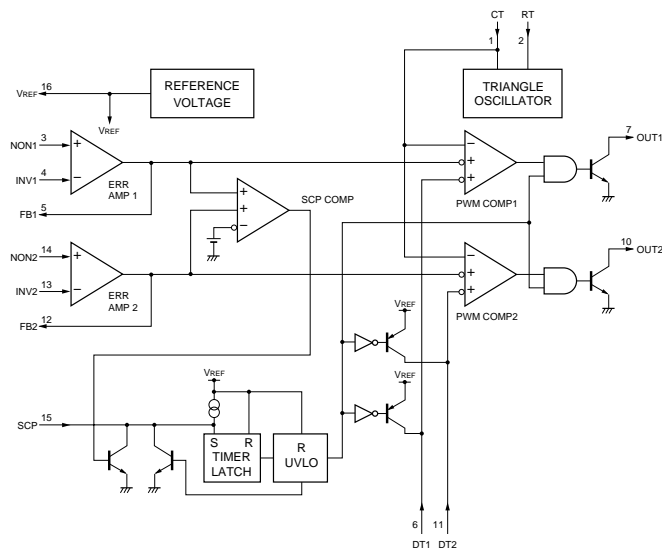

DG613-DY (SILICONIX)

D/CMOS QUAD ANALOG SWITCHES
—TOP VIEW—

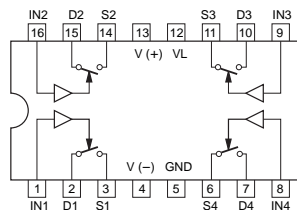

TRUTH TABLE

LOGIC	S1,S4	S2,S3	
0	OFF	ON	LOGIC "0" ≤ 1 V
1	ON	OFF	LOGIC "1" ≥ 4 V

HFA1135IB (HARRIS)

OPERATIONAL AMPLIFIER

—TOP VIEW—

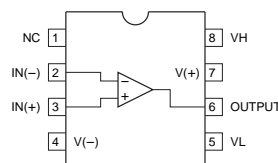

LM4041EIM3-1.2 (FSC)

SHUNT VOLTAGE REFERENCE

—TOP VIEW—

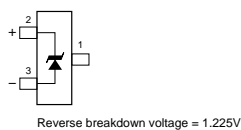

CA3094M (HARRIS)

PROGRAMMABLE POWER SWITCH/AMPLIFIER

—TOP VIEW—

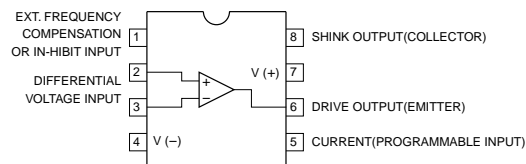

Section 5
Block Diagram

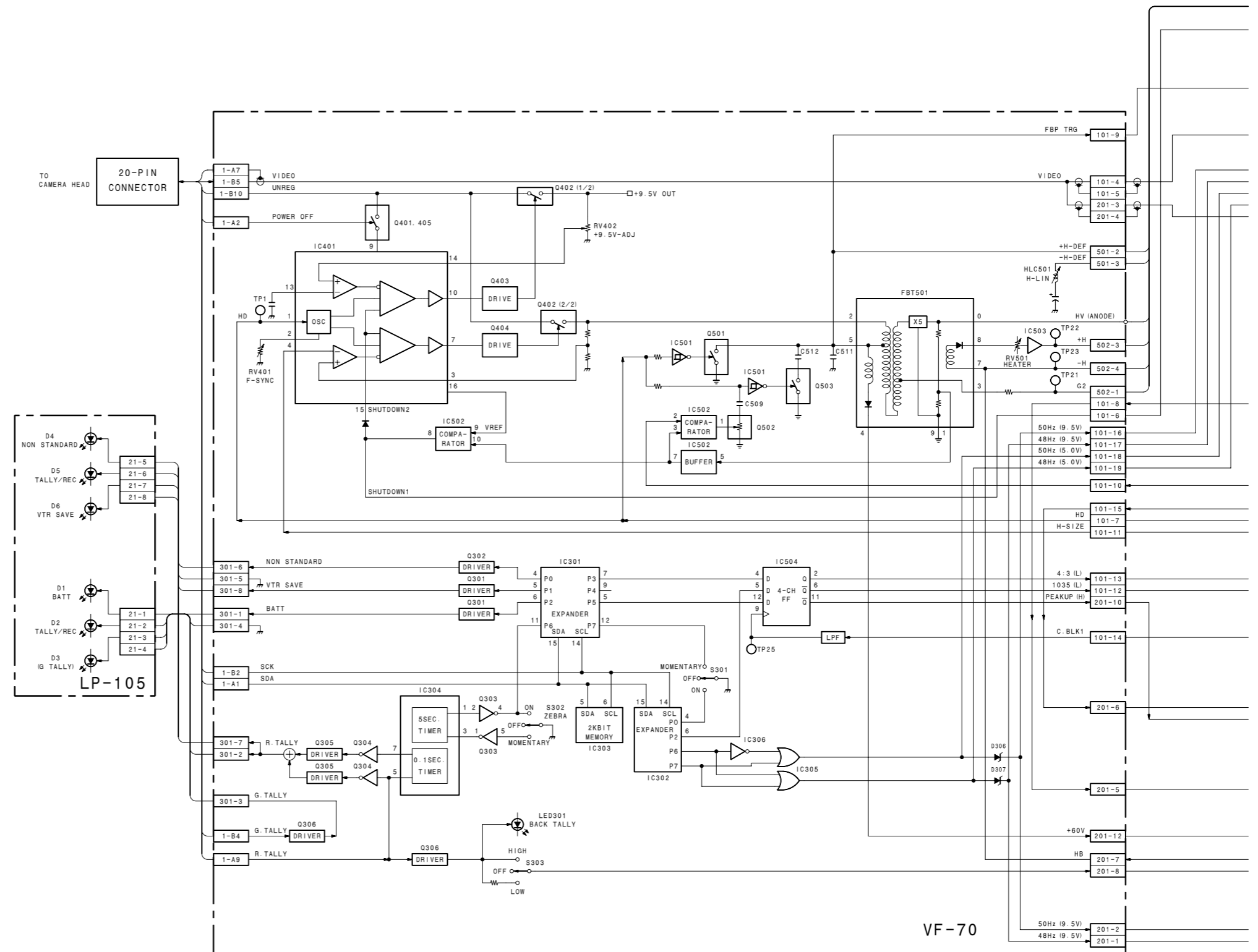

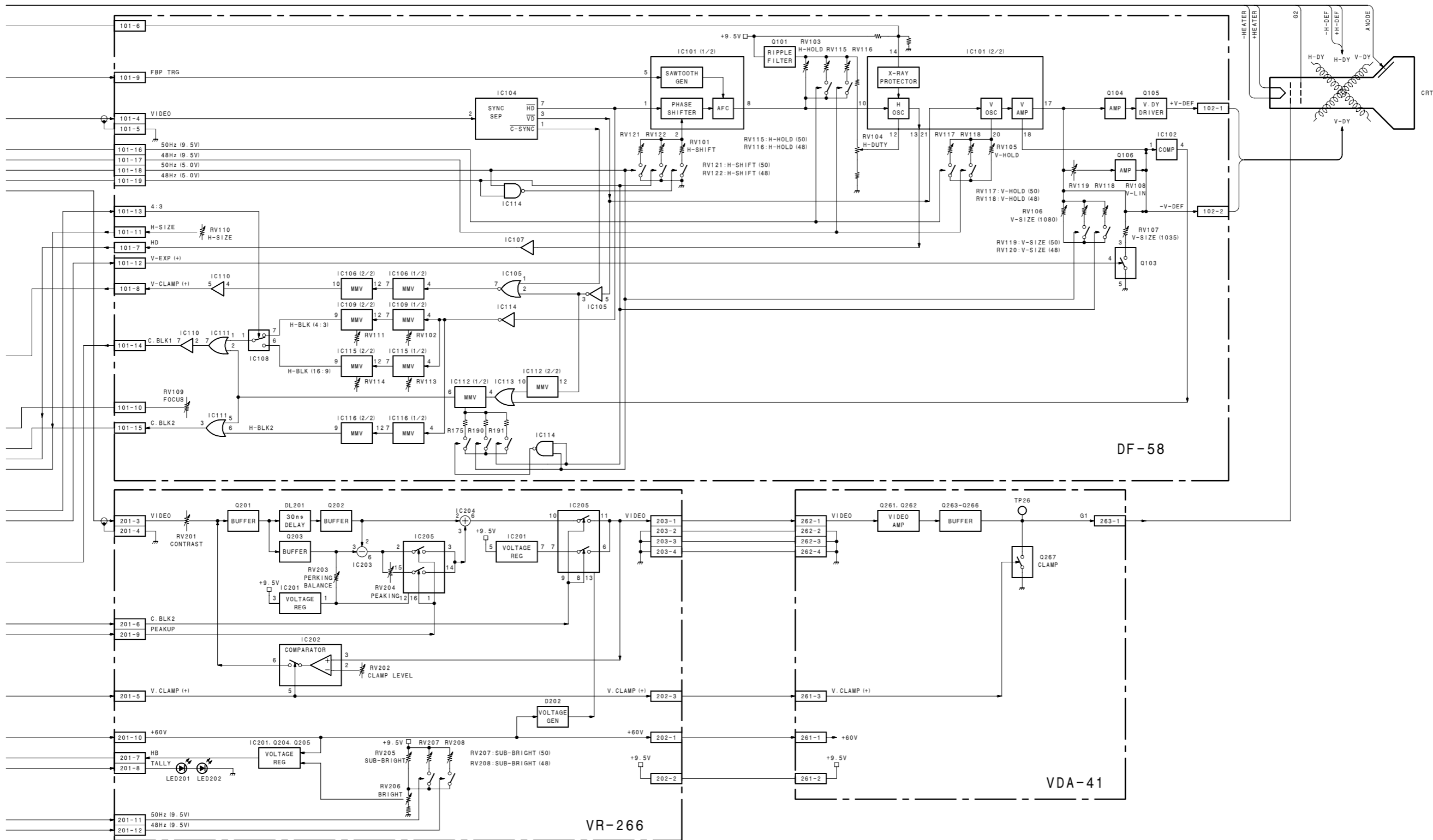

Section 6
Schematic Diagrams

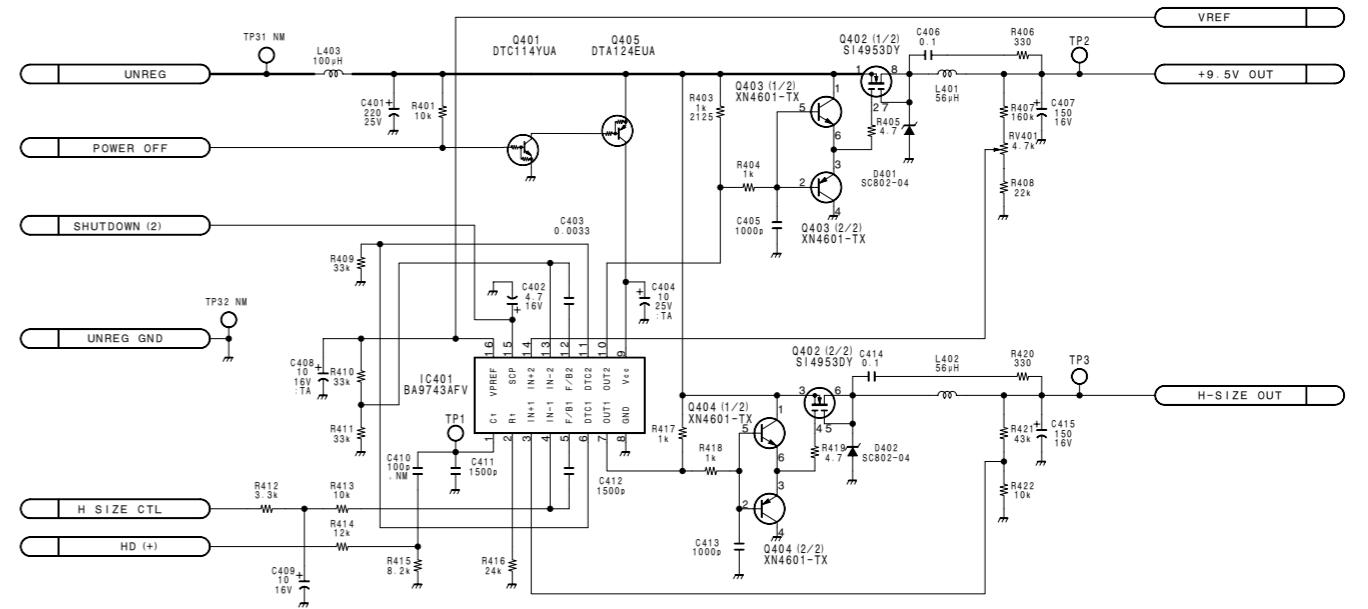
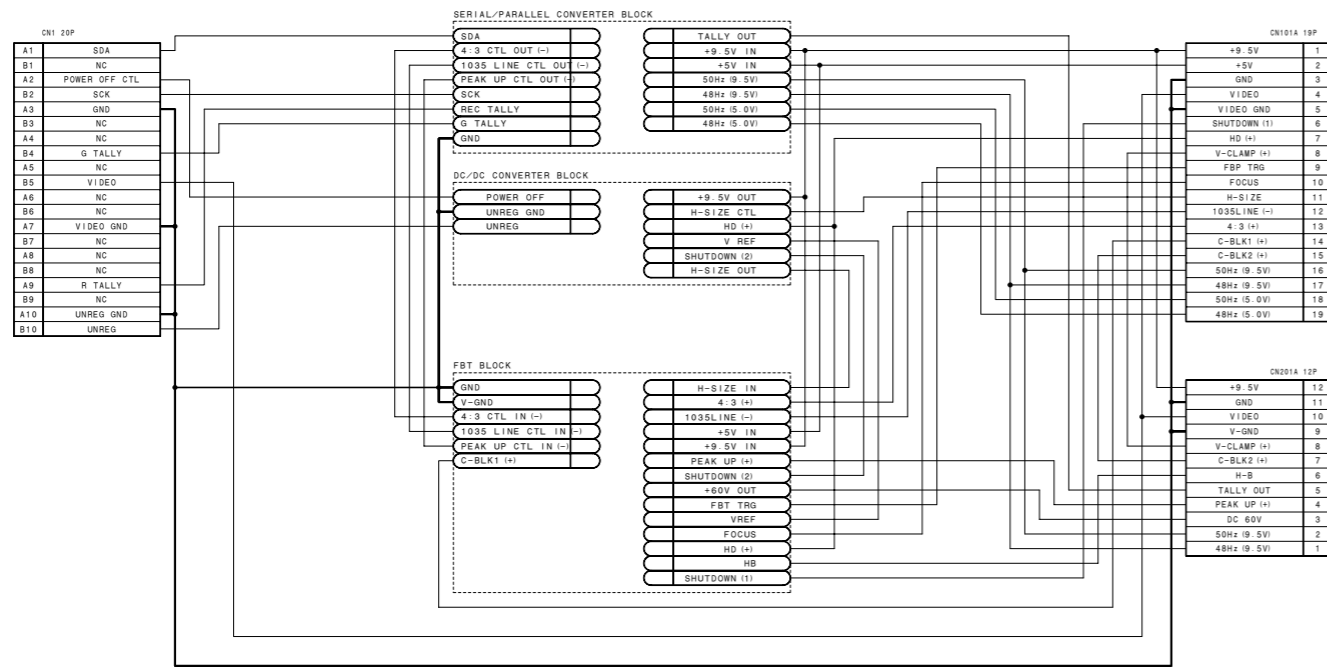

VF-70 (1/4)
BOARD NO. 1-761-333-11
LOT NO. 911-

VF-70 (2/4)
BOARD NO. 1-761-333-11
LOT NO. 911-

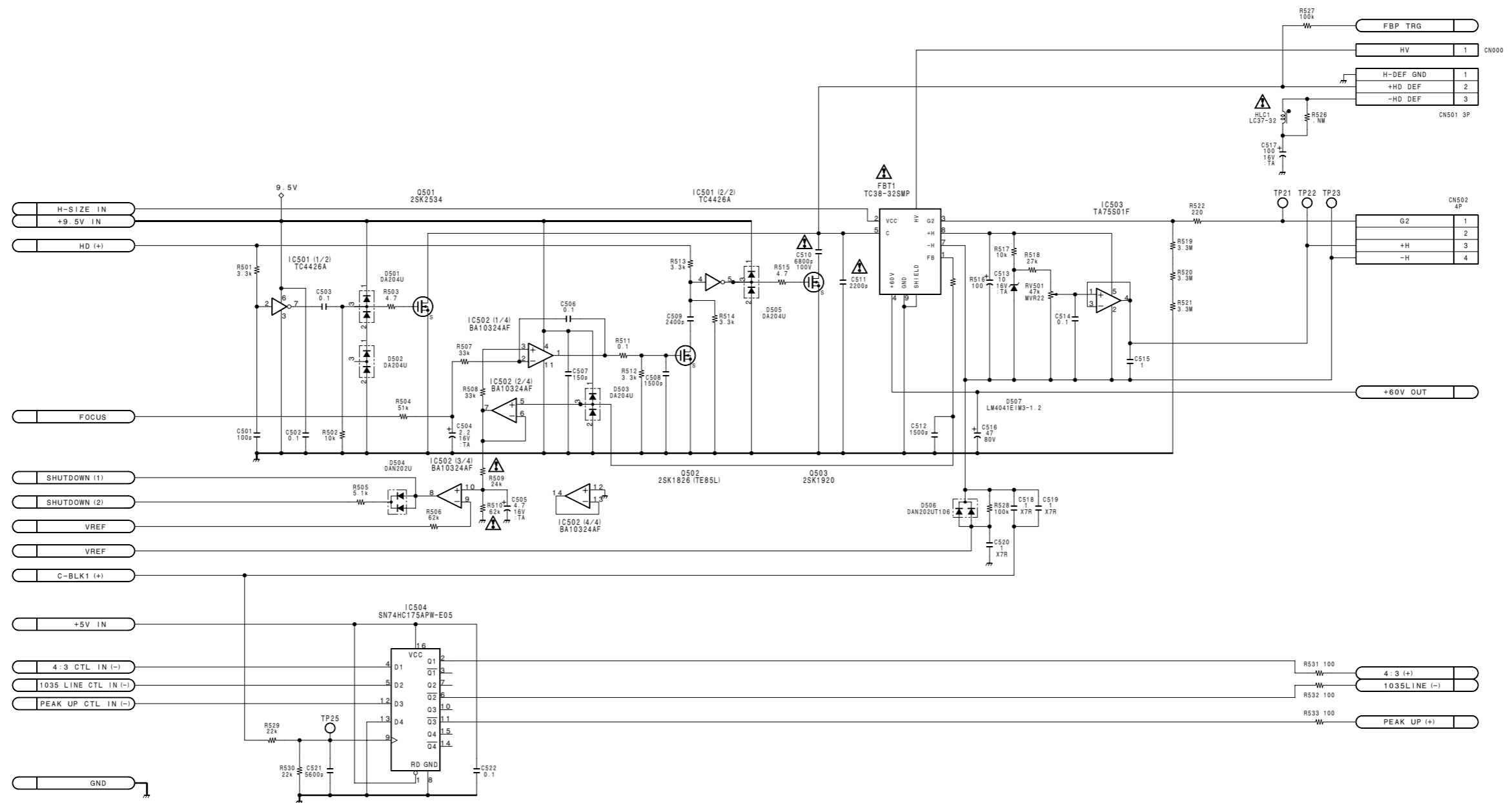

VF-70 (3/4)
 BOARD NO. 1-761-333-11
 LOT NO. 911-

1

2

3

4

5

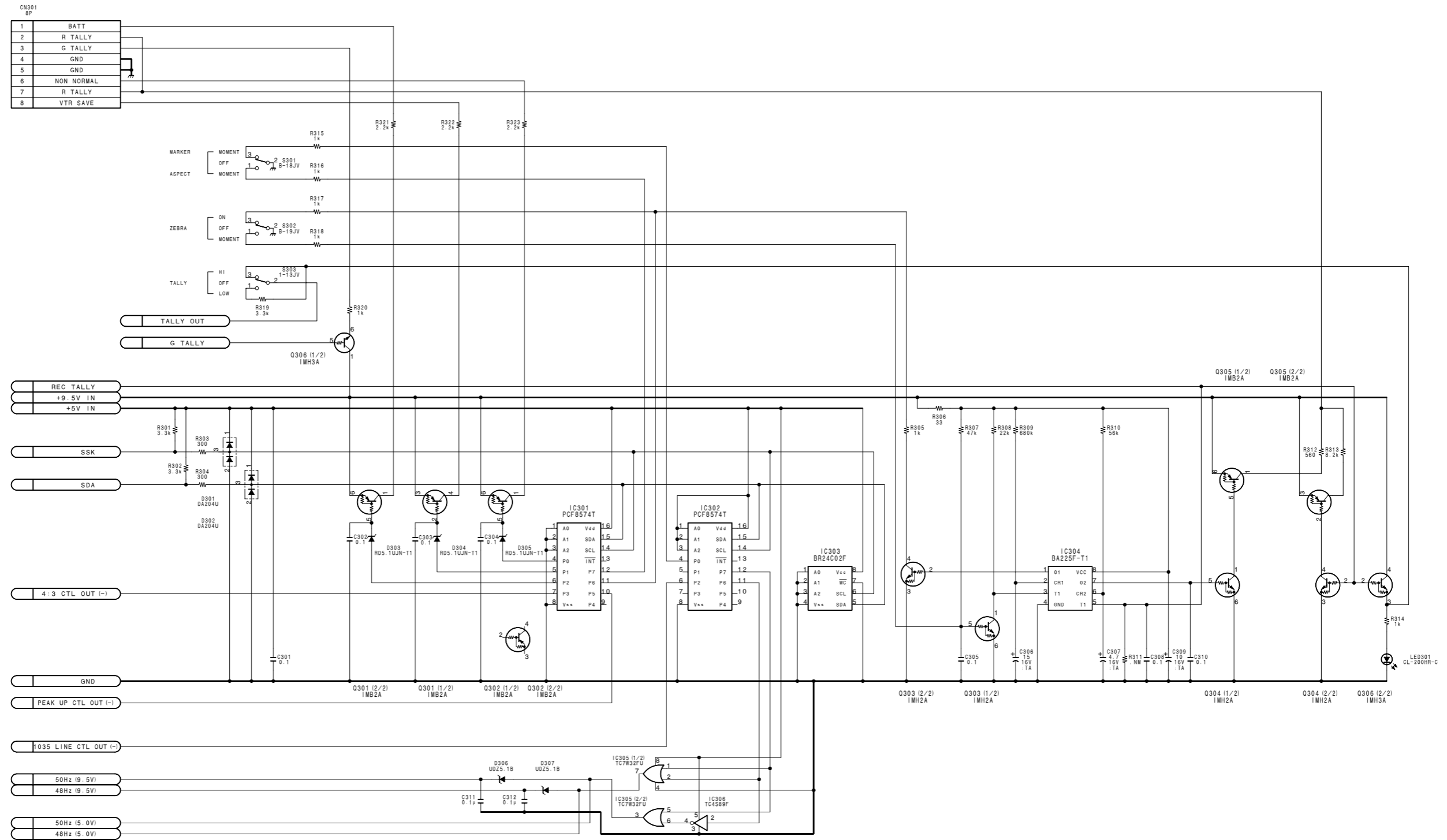

VF-70 (4/4)
 BOARD NO. 1-761-333-11
 LOT NO. 911-

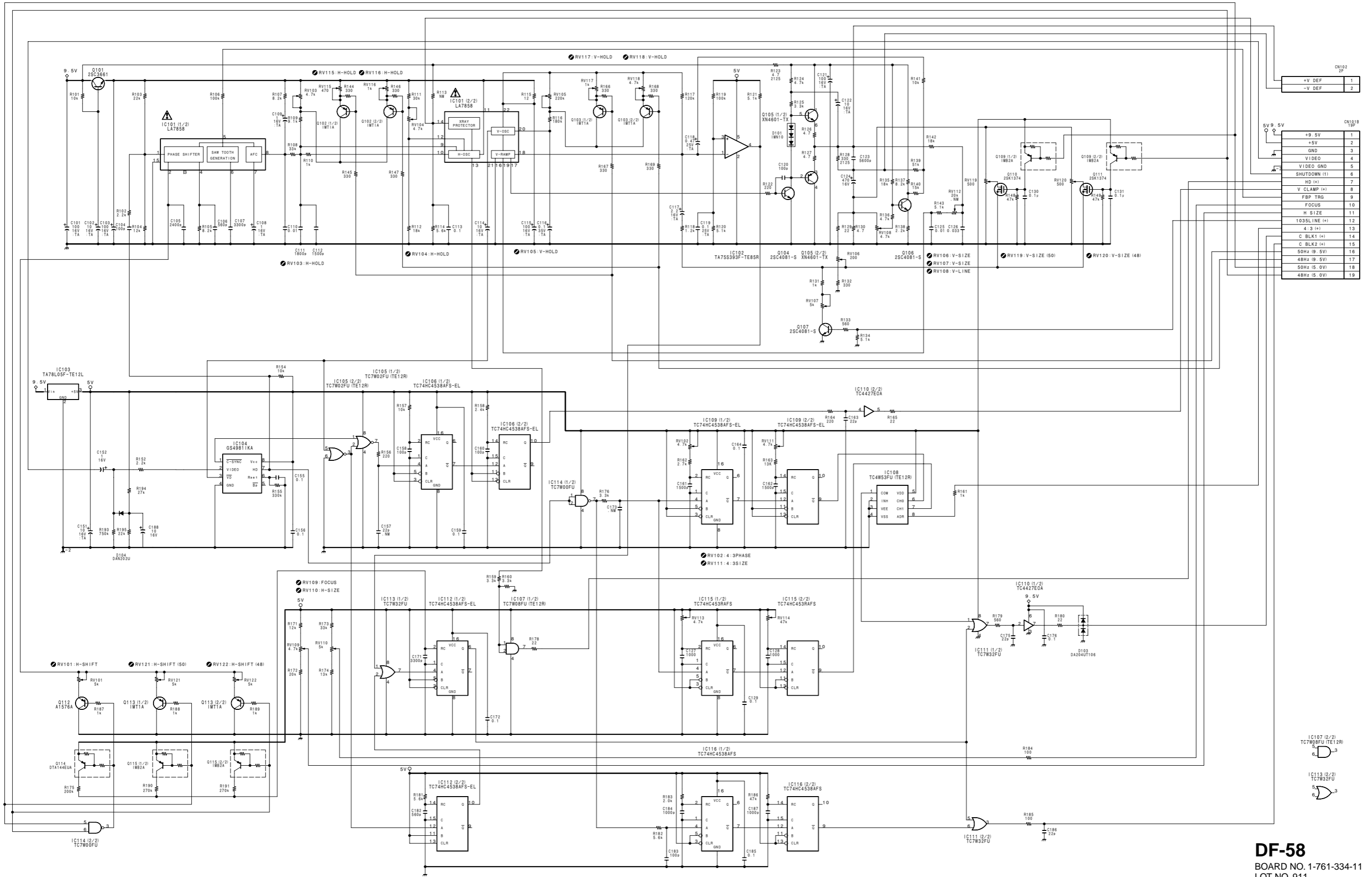

DF-58
 BOARD NO. 1-761-334-11
 LOT NO. 911-

VR-266, VDA-41 VR-266, VDA-41

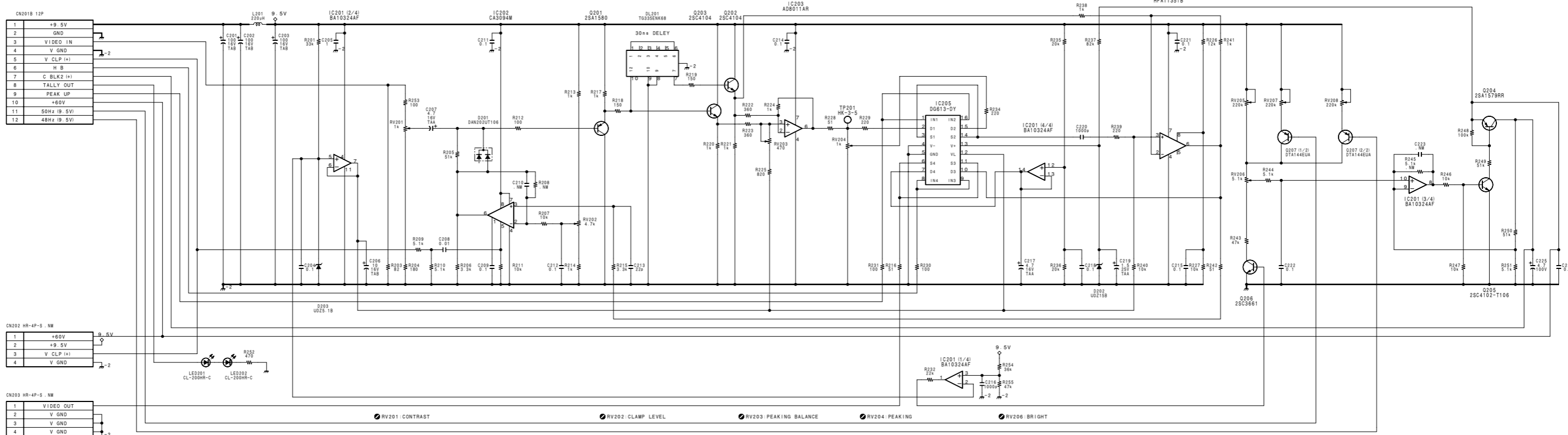

VR-266
BOARD NO. 1-761-335-11
LOT NO. 911-

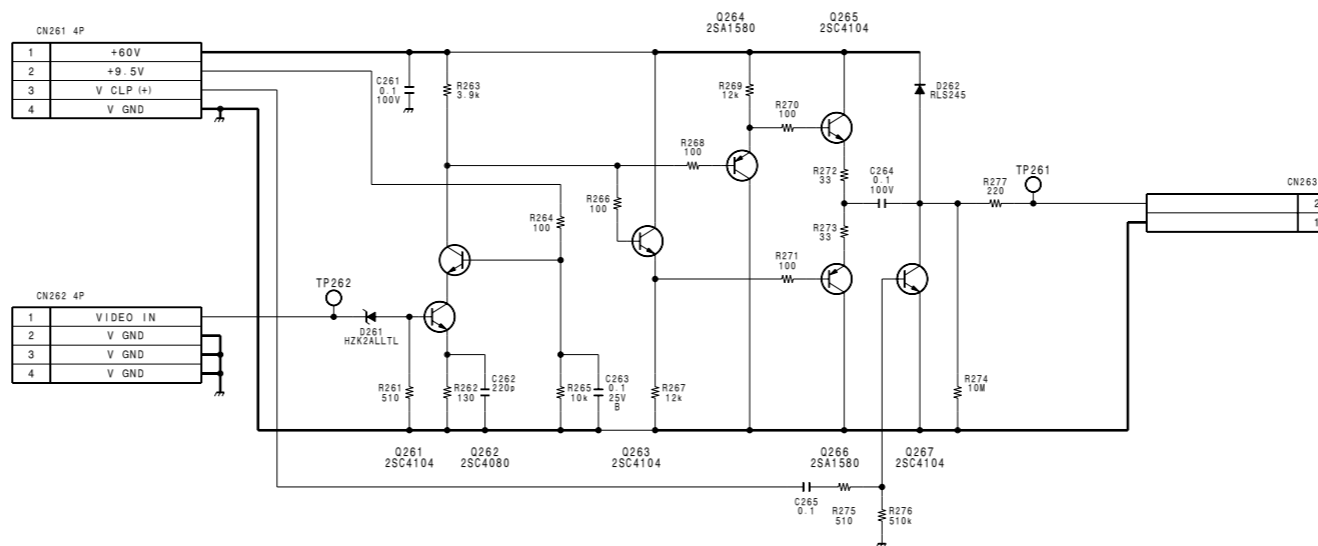

VDA-41
BOARD NO. 1-761-339-11
LOT NO. 911-

Frame Wiring Frame Wiring

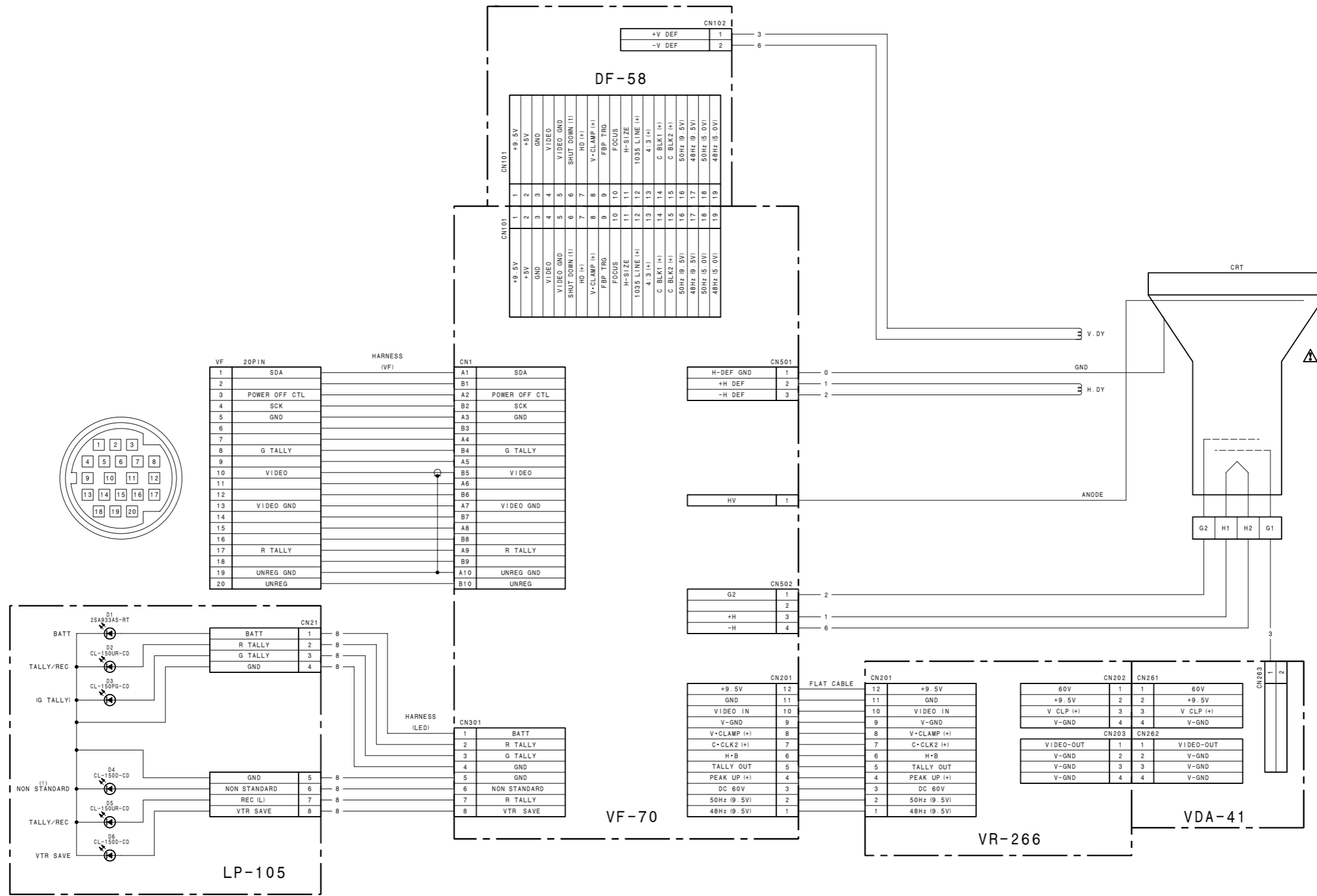

1

2

3

4

5

A B C D E F G H

Section 7 Board Layouts

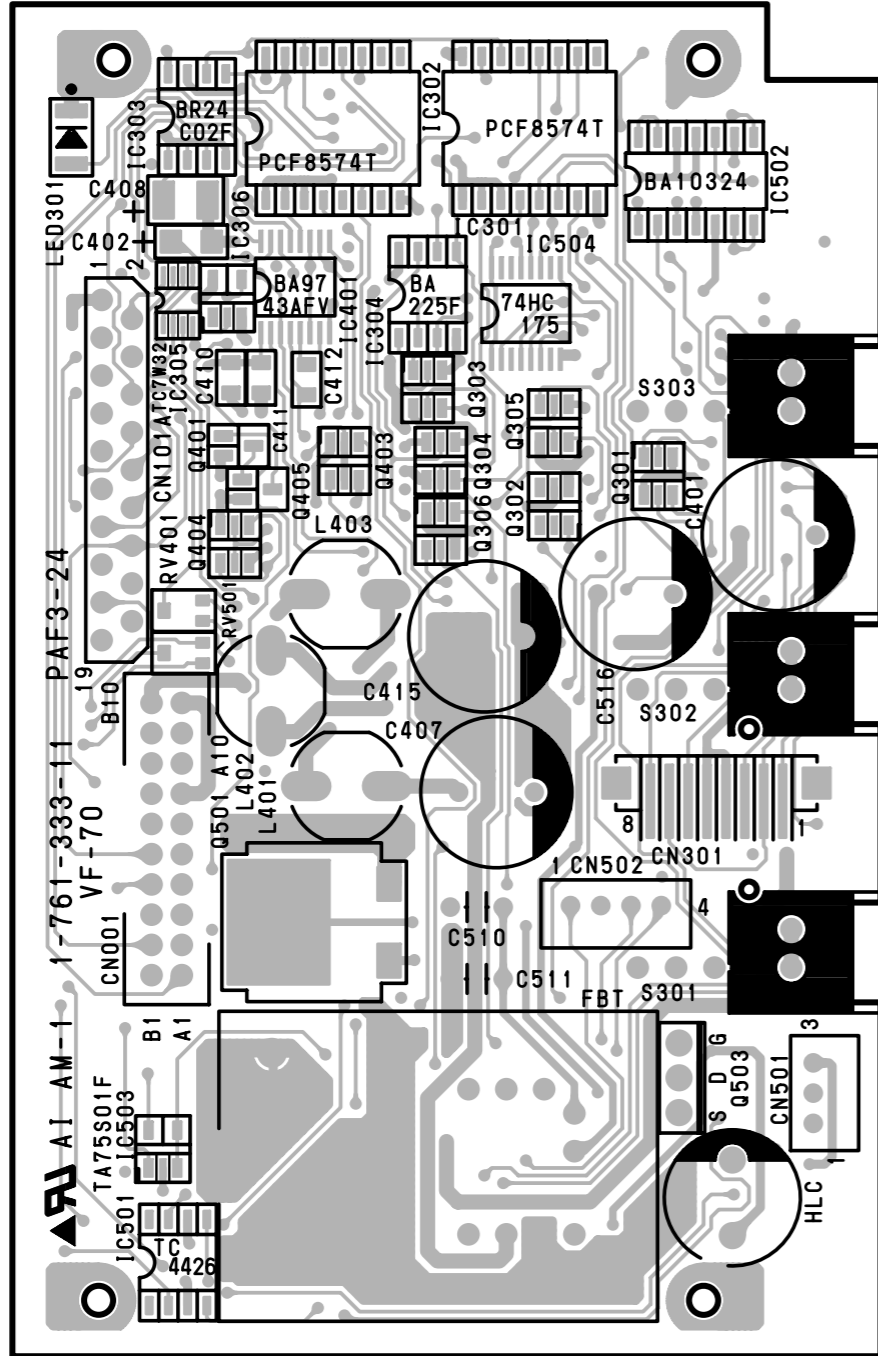

VF-70 -COMPONENT SIDE-
SUFFIX: -11

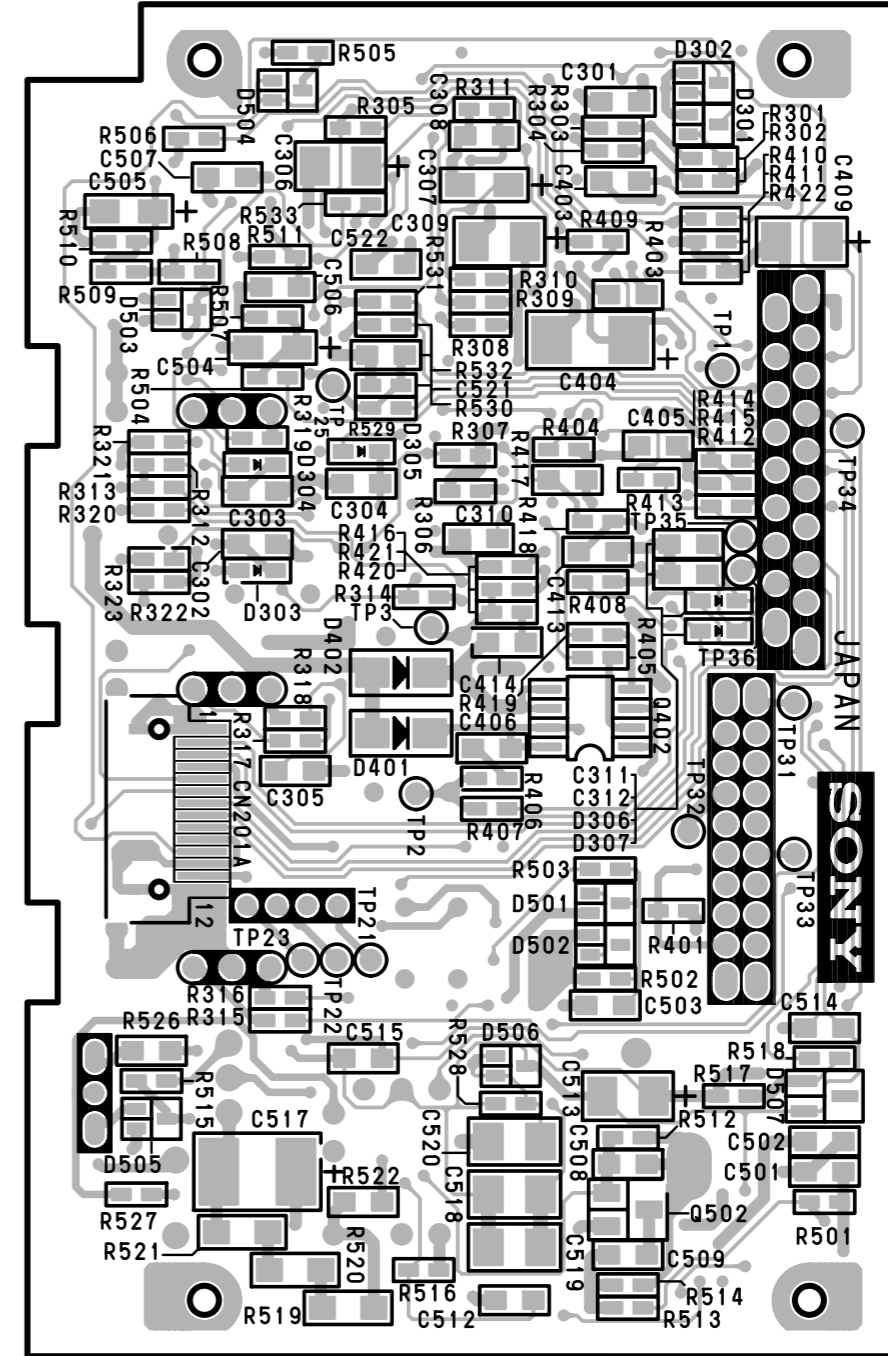

VF-70 -SOLDERING SIDE-
SUFFIX: -11

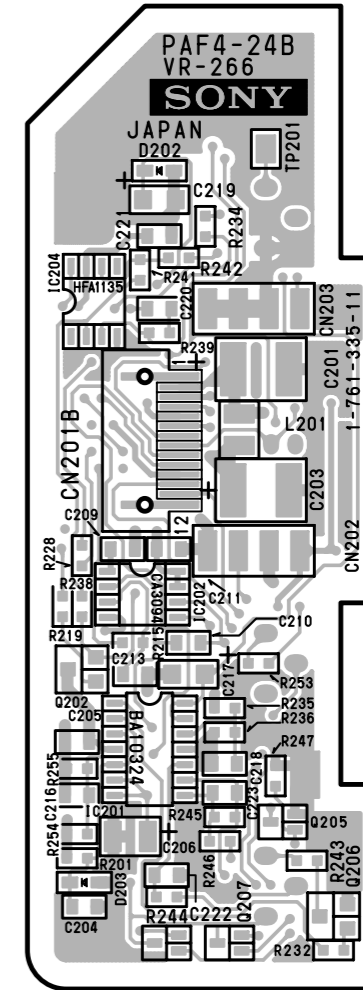
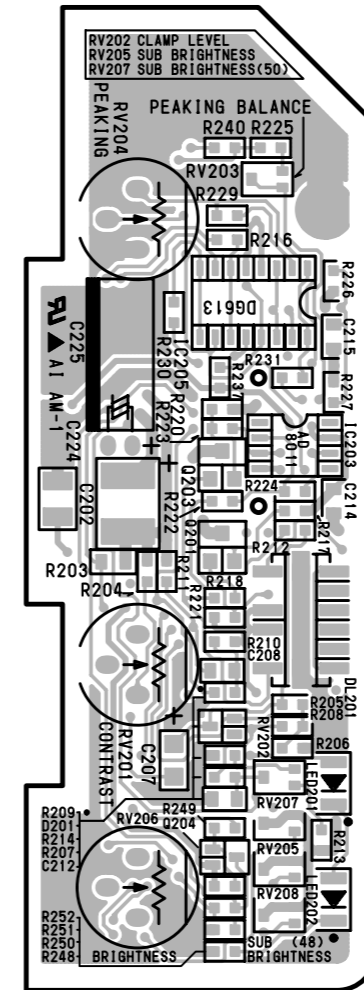
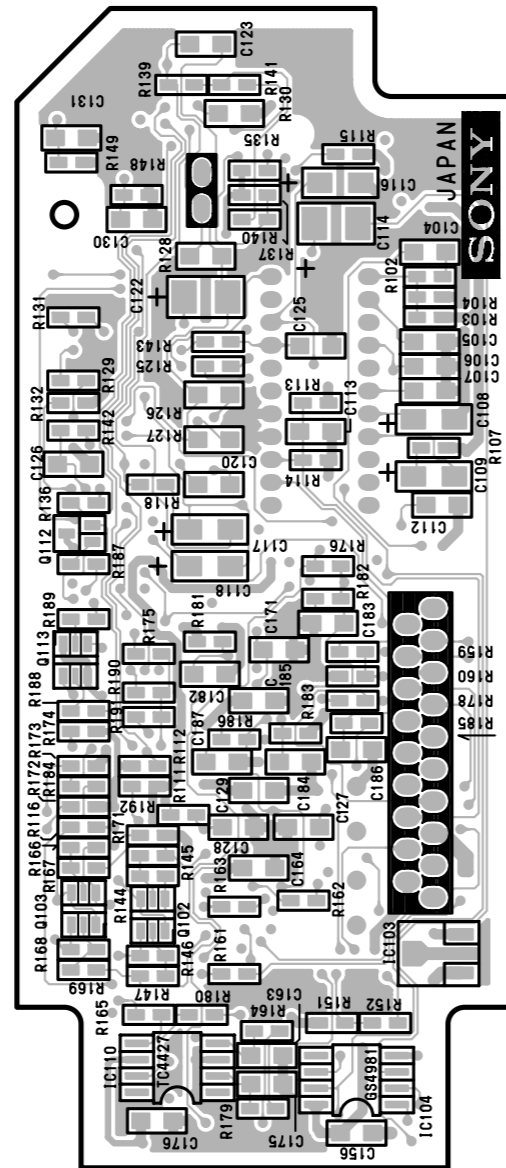
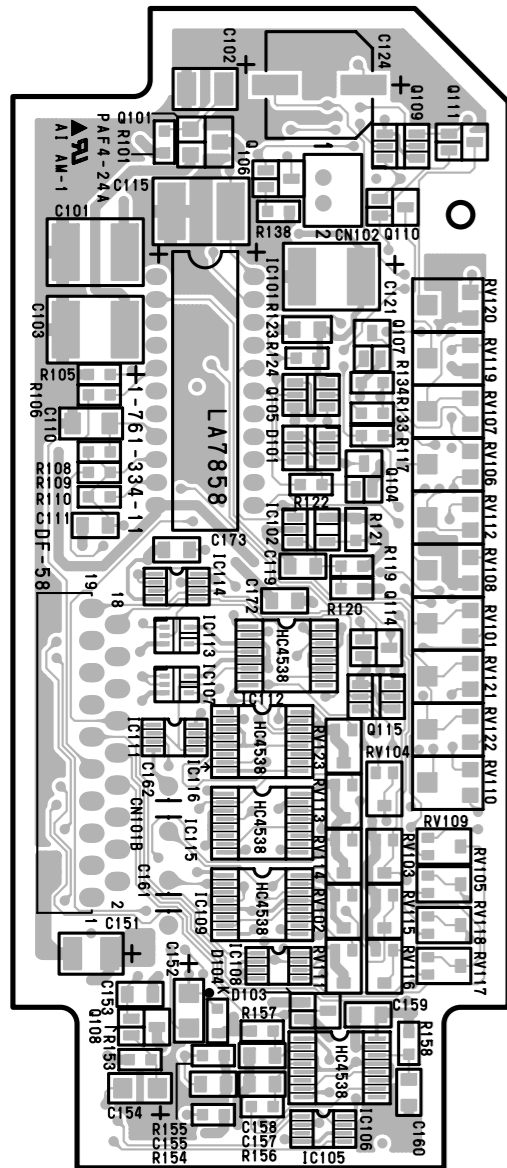

VR-266 -COMPONENT SIDE- SUFFIX: -11

VR-266 -SOLDERING SIDE- SUFFIX: -11

DF-58 -COMPONENT SIDE- SUFFIX: -11

DF-58 -SOLDERING SIDE- SUFFIX: -11

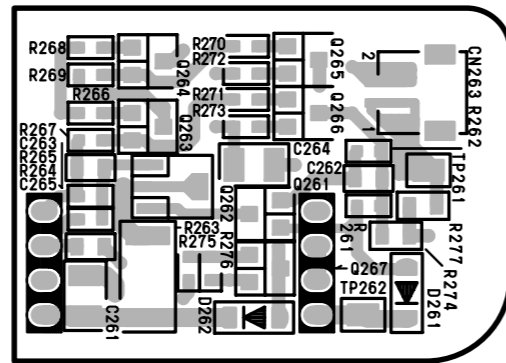
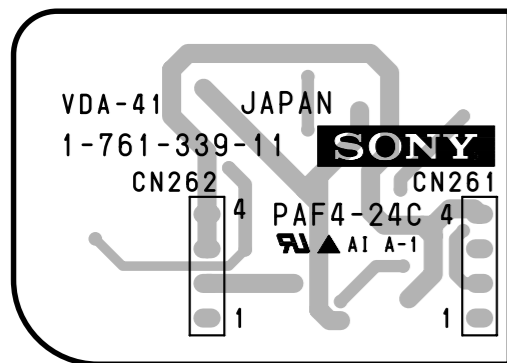

VDA-41 -COMPONENT SIDE- SUFFIX: -11

VDA-41 -SOLDERING SIDE- SUFFIX: -11

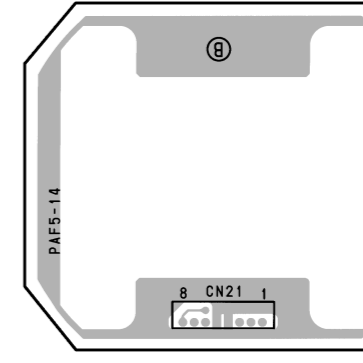
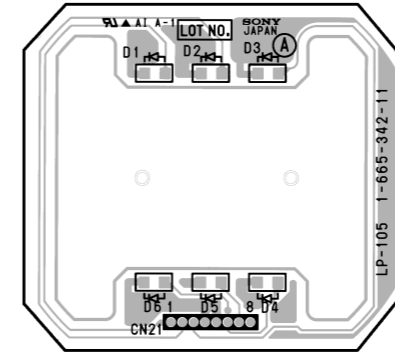

LP-105 -A SIDE- SUFFIX: -11

LP-105 -B SIDE- SUFFIX: -11

このマニュアルに記載されている事柄の著作権は当社にあります。

従って、当社の許可なしに無断で複写したり、説明内容(操作、保守等)と異なる目的で本マニュアルを使用することを禁止します。

The material contained in this manual consists of information that is the property of Sony Corporation. Sony Corporation expressly prohibits the duplication of any portion of this manual or the use thereof for any purpose other than the operation or maintenance of the equipment described in this manual without the express written permission of Sony Corporation.

Le matériel contenu dans ce manuel consiste en informations qui sont la propriété de Sony Corporation. Sony Corporation interdit formellement la copie de quelque partie que ce soit de ce manuel ou son emploi pour tout autre but que des opérations ou entretiens de l'équipement à moins d'une permission écrite de Sony Corporation.

Das in dieser Anleitung enthaltene Material besteht aus Informationen, die Eigentum der Sony Corporation sind. Die Sony Corporation untersagt ausdrücklich die Vervielfältigung jeglicher Teile dieser Anleitung oder den Gebrauch derselben für irgendeinen anderen Zweck als die Bedienung oder Wartung der in dieser Anleitung beschriebenen Ausrüstung ohne ausdrückliche schriftliche Erlaubnis der Sony Corporation.

