

# Lowell Wall-mount Rack with fixed-rails

## Description:

The economical LWRF wall-mount rack with fixed-rails is a contemporary solution to house electronics in small system installations like schools and offices. It's ideally suited for light to medium load applications (up to 150 lbs. for 7 or 10U models, up to 100 lbs. for 4U models) where easy access to the rear of rack-mounted equipment is not a priority. The welded 16-ga. steel rack features 1-pair of fixed mounting rails, vented sides and a separate wall bracket with mounting slots and knockouts. Front rails are set back approximately 0.83". Durable black wrinkle powder epoxy finish.



An optional front door with key lock for security can be ordered separately for added security.

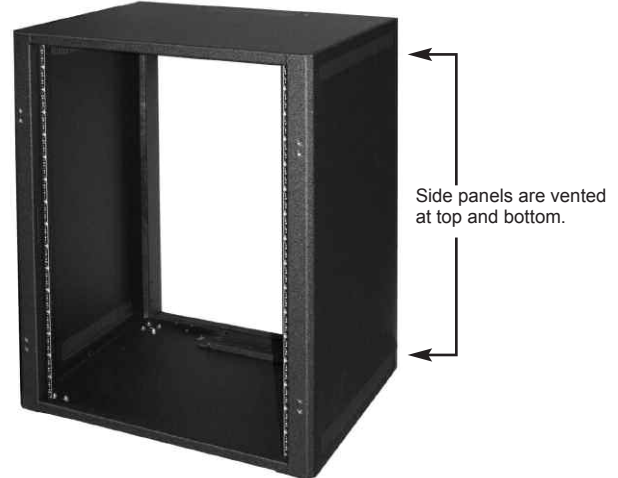

Side panels are vented at top and bottom.

Rack features combination knockout panel on bottom and project panel on top.

## Features:

- Overall width: 23.06"
- Rail-mounting width: 19" EIA
- One pair fixed front mounting rails tapped 10-32
- Open front
- Rear wall-mount bracket
- Side panels vented at top and bottom
- 150 lbs. load capacity (7U and 10U models)
- 100 lbs. load capacity (4U model)
- Removable knockout panels (one blank project panel on top, one panel with .5"--.75", .5" and 1.5"-1" knockouts on bottom)
- Beveled front corners
- Made in the U.S.A. with 100% certified U.S. steel

## Optional: (order separately)

- **Front Door:** an optional surface-mount front door (solid steel, fully-vented steel, or steel with smoked Plexiglas insert) can be added to 7U or 10U models. See LFD-series.
- **Additional Mounting Rails (RRTF-series):** an additional pair of rails can be ordered to mount in a fixed position in the rear of the rack.
- **Rail Conversion Bracket (RRTBF):** bracket enables front rails (or optional rear rails) to change from fixed position to adjustable style. Includes hardware.

Rack includes sturdy, rear wall-mount bracket.

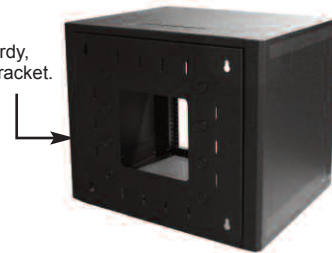

## A&E Specifications:

The wall-mount rack shall be Lowell Model \_\_\_\_\_, which shall measure 22.06"W x 18.18"D x \_\_\_\_\_"H. The welded assembly shall be 16-ga. certified US steel with 11-ga. fixed front mounting rails tapped 10-32. The rack shall feature side ventilation slots and a rear wall-mount bracket. The load capacity shall be \_\_\_\_\_. Finish shall be black powder epoxy.

Model No.	Description	Rack Units*	Overall H	Overall D	Usable D	Overall W	Carton Pack	Carton Wt.
LWRF-418	Lowell wall-mount rack with fixed-rails	4	11.38"	18.18"	17.20"	23.06"	1	36 lbs.
LWRF-718	Lowell wall-mount rack with fixed-rails	7	16.63"	18.18"	17.20"	23.06"	1	45 lbs.
LWRF-1018	Lowell wall-mount rack with fixed-rails	10	21.88"	18.18"	17.20"	23.06"	1	54 lbs.
RRTF-4	Additional Rack Rails	4	7.00"				1-pr	2 lbs.
RRTF-7	Additional Rack Rails	7	12.25"				1-pr	3 lbs.
RRTF-10	Additional Rack Rails	10	17.50"				1-pr	3 lbs.
RRTBF	Rail Conversion Bracket						1-kit	6 lbs.

\*One Rack Unit (RU or U) = 1.75"

# Lowell Wall-mount Rack with fixed-rails

## LWRF-418

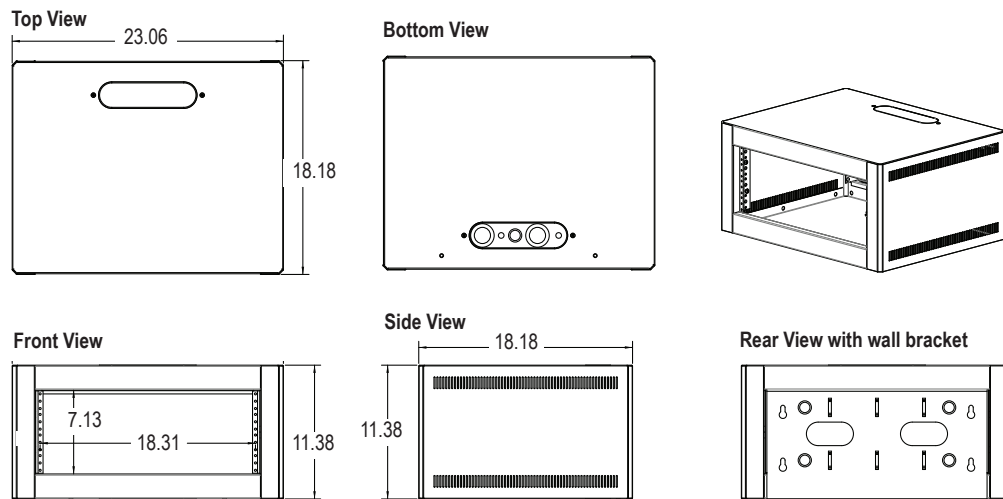

## LWRF-718

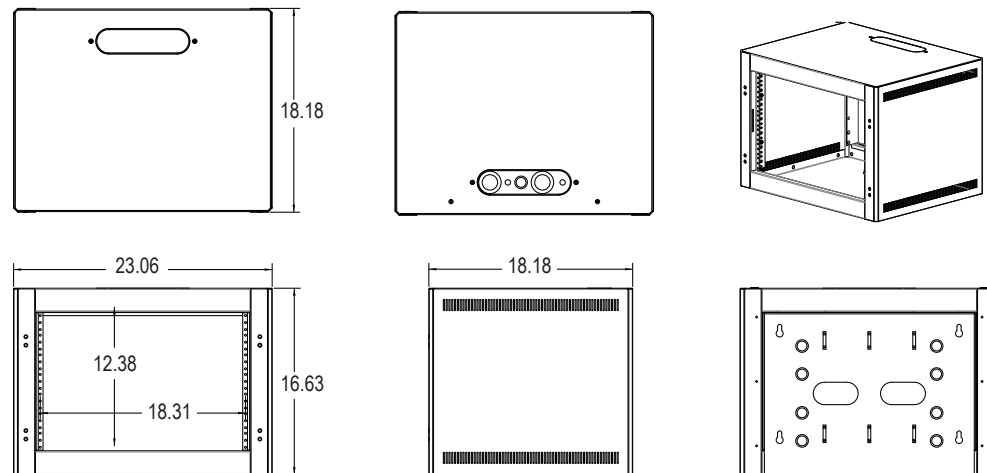

## LWRF-1018

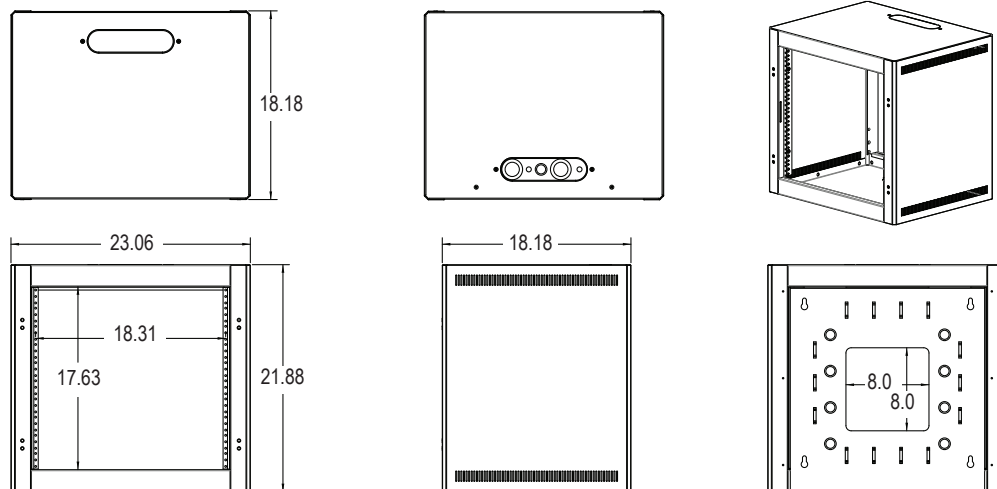

All measurements are inches.