

TCS SERIES ENGINEERING INFORMATION

The TCS-59 is a passive full range two-way loudspeaker enclosure designed for use in primary speech and music sound reinforcement applications.

The loudspeaker complement consists of a custom front loaded 12" low frequency driver and a 1" high frequency compression driver on a 90° x 60° constant directivity horn, matched with an internal passive crossover network.

The large format constant directivity horn exhibits excellent pattern control down to crossover frequency, making the TCS-59 ideal for use in arrays.

The trapezoidal enclosure is constructed from 5/8" (15mm) birch plywood, and incorporates M10 threaded internal steel rigging brackets which are designed to accept standard eyebolts and optional Turbosound mounting hardware, providing a simple and convenient method of flying the cabinet.

A rear panel connector plate carries a single Neutrik Speakon NL4MP and a 4-way terminal strip for loop in and loop out connections to additional enclosures.

Recommended complementary products:

TCS-40 downfill enclosure

TCS-108, TCS-215, TCS-118 subwoofer enclosures

LMS-D6, LMS-D4 loudspeaker management systems

**FEATURES**

Excellent pattern control

90° x 60° dispersion

High power handling

APPLICATIONS

Front of house array

Houses of Worship

Corporate / industrial

DIMENSIONS (HxWxD)	700mm x 370mm x 389mm (27.6" x 14.6" x 15.1")
NET WEIGHT	22kgs (48.4lbs)
COMPONENTS	1 x custom 12" (305mm) LF driver, 1 x 1" (25mm) HF driver on a custom flare
FREQUENCY RESPONSE¹	60Hz - 20kHz ±4dB
NOMINAL DISPERSION²	90°H x 60°V@-6db points
POWER HANDLING	290 watts r.m.s., 580 watts program, 725 watts peak Recommended amplifier 580 watts @ 8 ohms
SENSITIVITY³	97dB 1 watt @ 1 m
MAXIMUM SPL	125dB continuous ⁴ , 131dB peak ⁵
CROSSOVER	Internal passive crossover at 1k6Hz; 24dB/octave high pass, 12dB/octave low pass
NOMINAL IMPEDANCE	8 ohms
CONSTRUCTION	15mm (5/8") birch plywood; rebated, screwed and glued. Finished in black semi-matt textured paint
GRILLE	Black powder coated perforated steel
CONNECTORS	Neutrik Speakon NL4MP, wired pin1+: positive, pin1-: negative Four way terminal strip for loop in/loop out connection
FLYING HARDWARE	(9) M10 internal steel rigging points
OPTIONS	Optional colours: blue, white, raw birch plywood
SPARES AND ACCESSORIES	LS-1213 12" (305mm) LF loudspeaker RC-1213 Recone kit for LS-1213 CD-107 1" (25mm) HF compression driver RD-107 Replacement diaphragm for CD-107 PX-59 Crossover assembly MG-50 Replacement perforated metal grille CB-100 Ceiling bracket WB-100 Wall bracket

Notes

¹Measured on axis

²Average over stated bandwidth

³Average over stated bandwidth

⁴Unweighted diode-clipped pink noise. Measured in a half space environment

⁵Verified by subjective listening tests of familiar program material, before the onset of perceived signal degradation

FREQUENCY RESPONSE

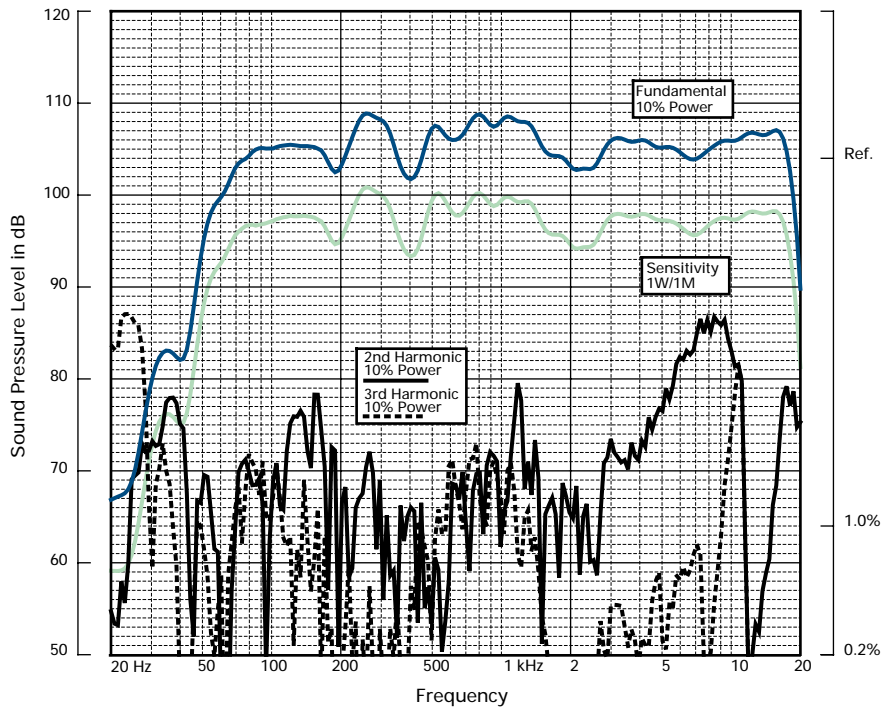

IMPEDANCE

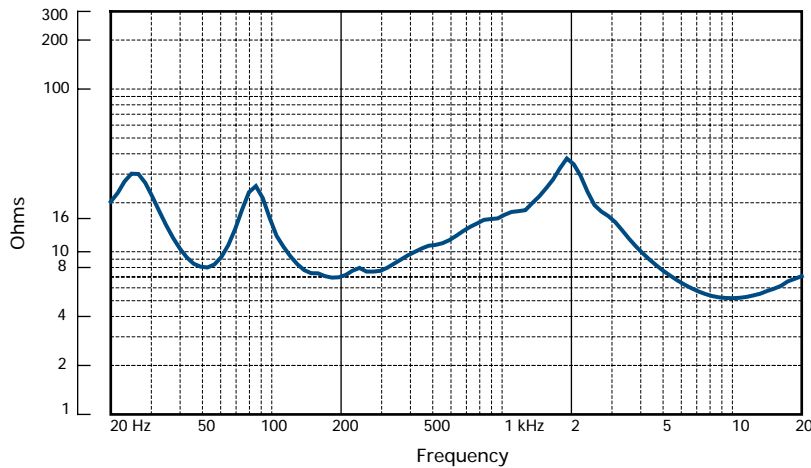

Impedance A constant current circuit was used to measure the impedance. **Frequency response** The frequency response shown was obtained by feeding a swept sine wave through the system in a half space environment. The position of the microphone was vertically on-axis at a distance of 2 metres, then scaled to represent 1 metre. **2nd & 3rd Harmonic Distortion** Distortion measurements were obtained using an Audio Precision harmonic distortion analysis system and comply with AES recommendations for enclosure measurement (AES paper ANSI S4-26-1984). **Data Conversion** All graphs were digitally generated using the APEX custom software system, designed to translate data derived from Audio Precision 'System One' test equipment into AutoCAD™. This program enables graphical information to be plotted to a high degree of accuracy.

NOTES ON MEASUREMENT CONDITIONS

HORIZONTAL THIRD
OCTAVE POLARS

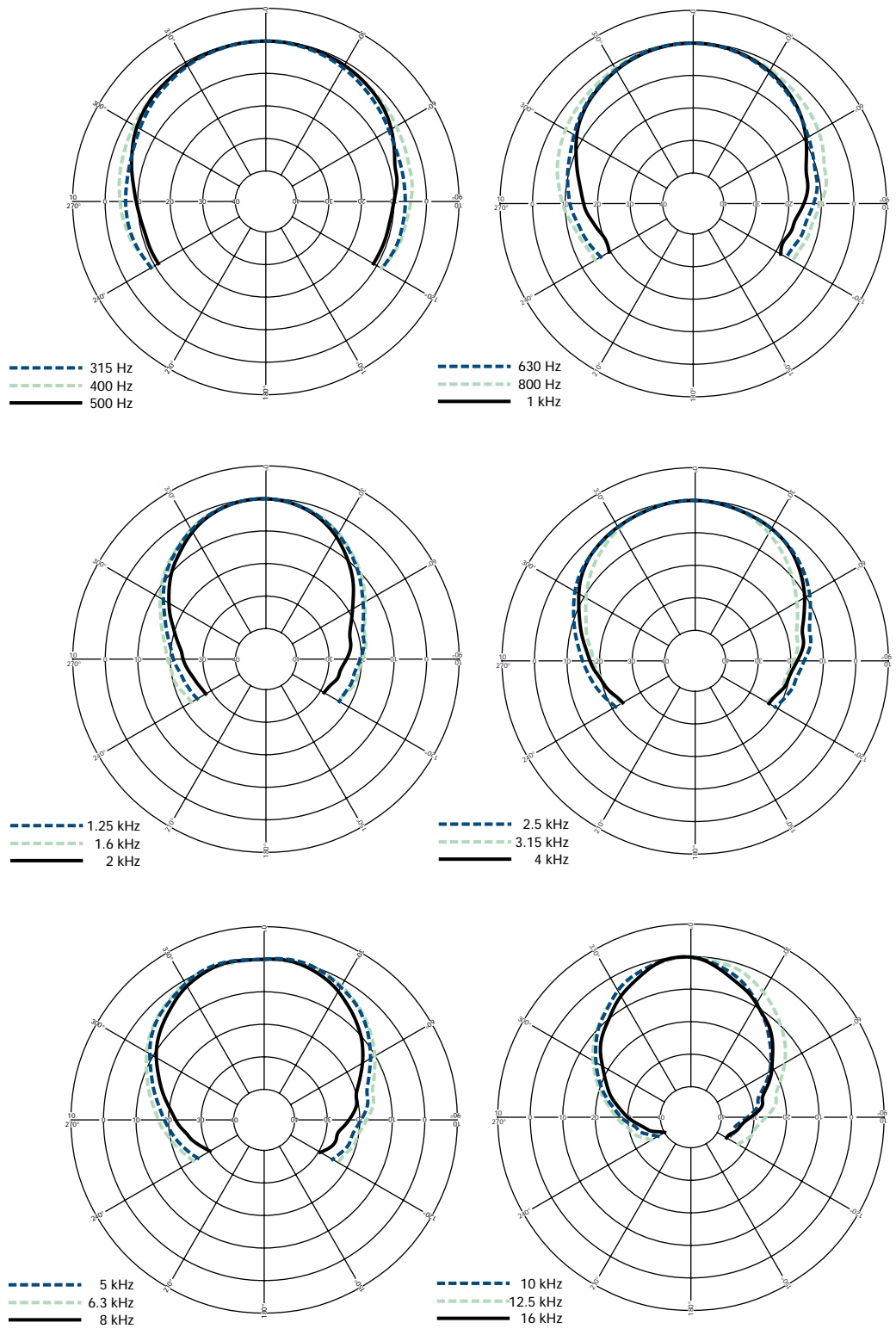

VERTICAL THIRD
OCTAVE POLARS

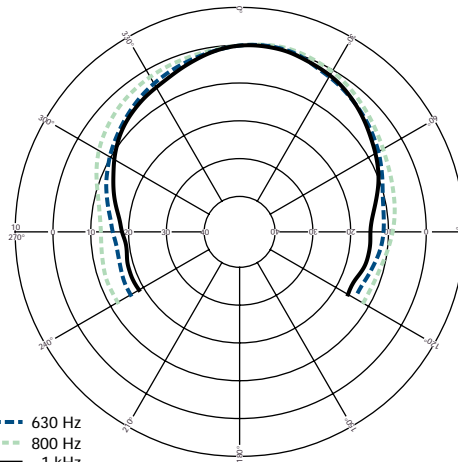
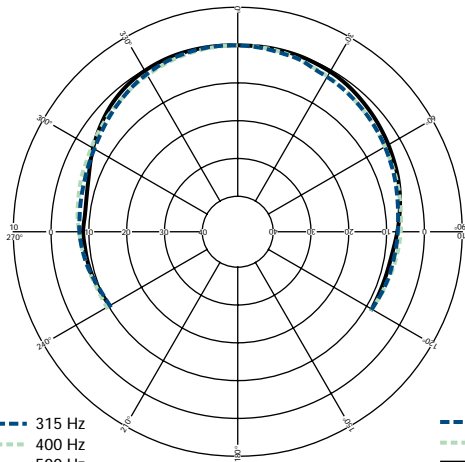

--- 315 Hz
--- 400 Hz
— 500 Hz

--- 630 Hz
--- 800 Hz
— 1 kHz

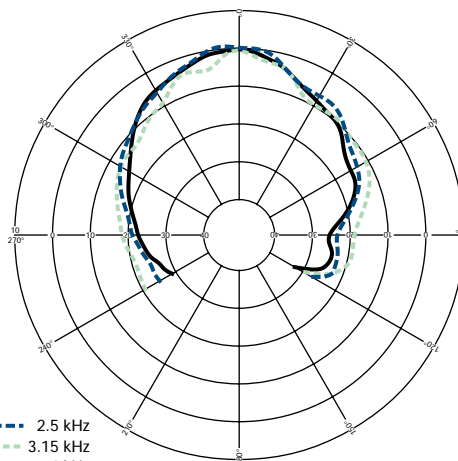
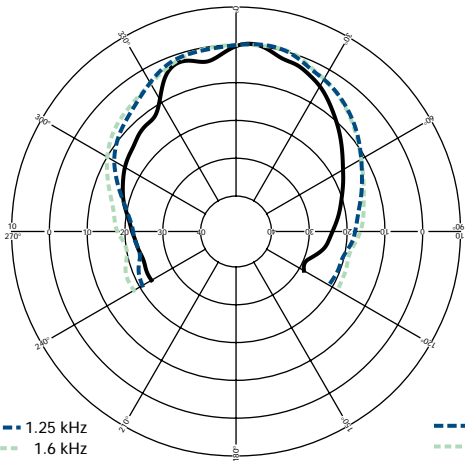

--- 1.25 kHz
--- 1.6 kHz
— 2 kHz

--- 2.5 kHz
--- 3.15 kHz
— 4 kHz

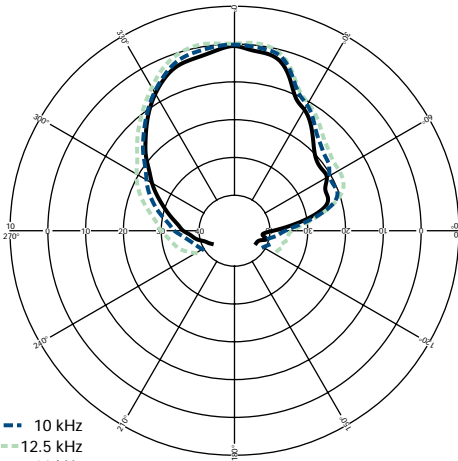
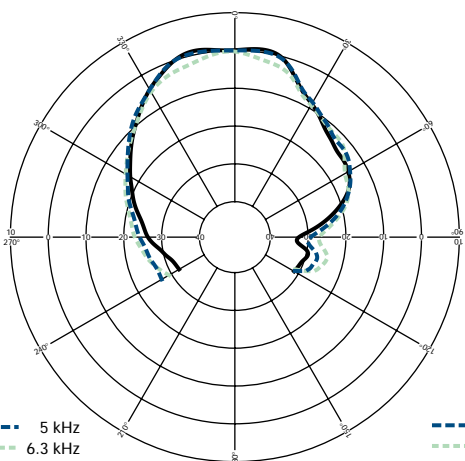

--- 5 kHz
--- 6.3 kHz
— 8 kHz

--- 10 kHz
--- 12.5 kHz
— 16 kHz

BEAMWIDTH

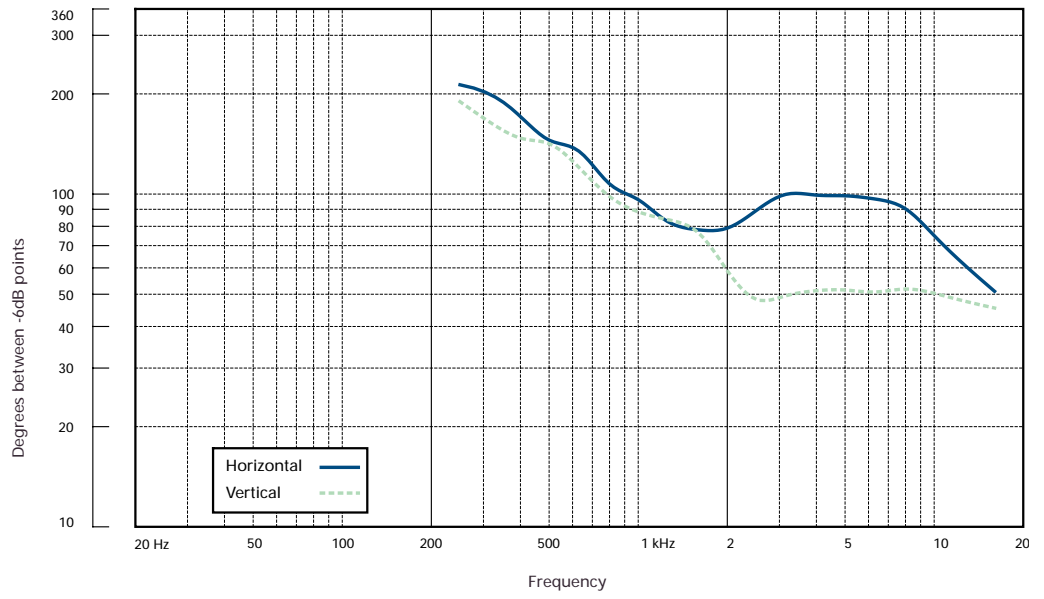

TCS SERIES ENGINEERING INFORMATION

The TCS-59 is fitted with M10 internal fittings on the top, bottom and rear of the cabinet which enable it to be permanently suspended from ceilings using standard eyebolts. Downward inclination is achieved by means of the rear fixing point. Optional Turbosound mounting hardware is also available for wall mounting (WB-100) and ceiling mounting (CB-100) the cabinet as shown. The enclosure can be angled and tilted to suit the exact requirements of sound coverage in the venue.

INSTALLATION HARDWARE

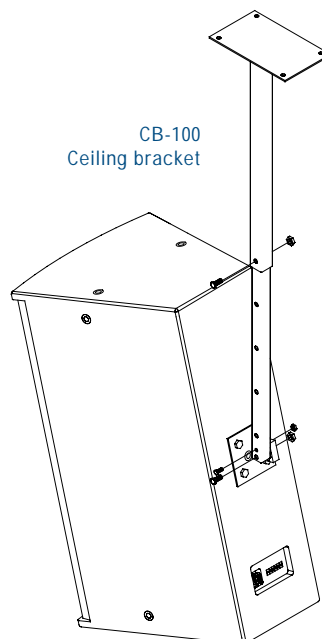
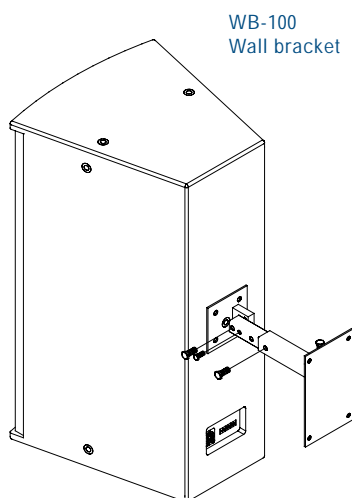
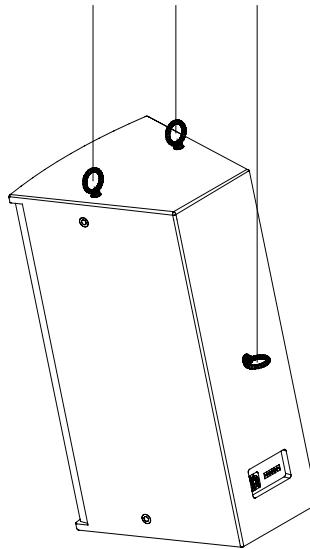
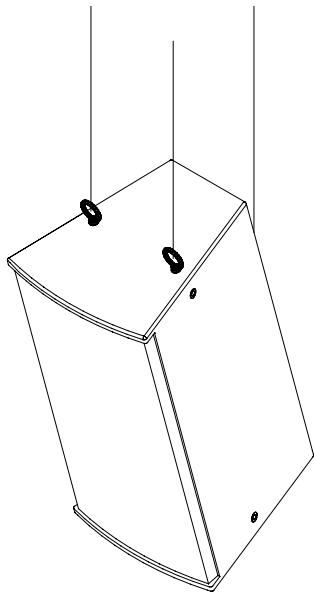

**ARCHITECTURAL
& ENGINEER'S
SPECIFICATIONS**

The system shall be of the two-way passive trapezoidal type consisting of one 12" (305mm) low frequency loudspeaker and one 1" (25mm) high frequency driver on a 90° x 60° constant directivity horn. Performance specifications of a typical production unit shall meet or exceed the following: frequency response, measured with swept sine wave input, shall be flat within 60Hz – 20kHz ±4dB. Nominal dispersion, at –6dB points, shall average 90°H x 60°V. Nominal impedance shall be 8 ohms. Power handling shall be 290 watts r.m.s., 580 watts program, 725 watts peak. Sensitivity, measured with 1 watt input at 1 metre distance on axis, mean averaged over stated bandwidth, shall be 97dB. Maximum SPL (peak) measured with music program at stated amplifier input shall be 131dB. Dimensions: 700mmH x 370mmW x 389D (27.6"H x 14.6"W x 15.3"D). The loudspeaker system shall be the Turbosound TCS-59. No other loudspeaker shall be acceptable unless submitted data from an independent test laboratory verify that the above combined performance / size specifications are equalled or exceeded.

DIMENSIONS

