

Lowell Wall-mount Swing-open Rack with fixed-rails

Description:

The LWSRF is an economical, two-part, E.I.A. compliant rack consisting of a 16-gauge steel backbox and mounting section. The mounting section attaches to the backbox with two heavy-duty bolts through steel fasteners with securing nuts. The backbox has two center-mount locks that are keyed differently than the (optional) front door.

Mounting section features vented sides and includes one-pair of fixed-position front mounting rails (tapped 10-32). To provide clearance for equipment knobs and front connections, rails are recessed from front frame, providing 1.38" space between equipment and (optional) surface-mount front door. The welded assembly mounts to the backbox with right- or left-hand swing.

Backbox features 16" mounting centers, removable knockout panels on top and bottom, 10"W wiring pathway down center (top to bottom), rear opening for mounting unit over electrical pull boxes, and two keyed center locks.

Installation note: Backbox and mounting section are boxed together. Mounting section provides 90-degree open-swing access for servicing and therefore requires a minimum swing clearance equivalent to mounting section depth plus one-inch for door (if optional front door is ordered). Rack includes PilotPoint screws with 5.1 hardness and captive washers (order RSP-series if extra hardware is desired).

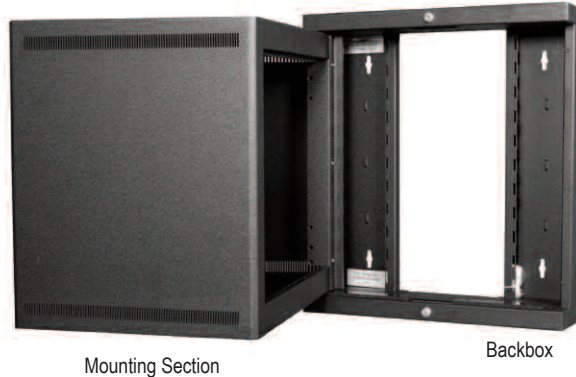

Mounting Section

Backbox

The economical LWSRF has a load capacity of 150 lbs.

Features:

- Load capacity: 150 lbs.
- Overall depth: 22.00"
- Overall width: 23.06"
- Knockout panels on top and bottom of backbox feature holes for wireless antennae and conduit (0.5" for BNC and compound knockouts for conduit size .75-.5" and 1.0-.5").
- Made in the U.S.A. with 100% certified U.S. steel
- Black wrinkle powder epoxy finish
- Beveled corners

Optional: (order separately)

- **Front Door:** surface-mount front door with key-lock available in solid steel, fully-vented steel or steel with smoked Plexiglas insert. (See LFD-series.)
- **Conversion Bracket (RRTBF):** bracket enables front rails (or optional rear rails) to change from fixed position to adjustable style. Includes hardware.
- **Rack Rails (RRTF-series):** thin-flange mounting rails provide additional support for rear of rack-mounted equipment. Rails include mounting hardware. Sold in pairs.

A&E Specifications:

The wall-mount rack shall be Lowell Model _____ with backbox and mounting section equipped with vents and key operated center locks. Mounting section shall measure 23.06"W x 19.06"D x _____H and have _____ rack unit space for mounting 19"W E.I.A. components. Mounting section shall include one pair of fixed-position front mounting rails (tapped 10-32) and mounting hardware. The mounting section shall attach to the backbox with heavy-duty bolts that can be moved to the opposite side to change swing orientation as needed. The backbox shall measure 3.65"D and be formed from 16-ga. certified U.S. steel with key-hole mounting slots on 16" centers. It shall include a central pathway and a rear opening to mount over electrical pull boxes. It shall also include removable knockout panels on the top and bottom, lacing points on the back plane, and two key locks in the center. Knockout panels shall have 0.5" knockouts for BNC and compound knockouts for conduit size 0.75- 0.5" and 1.0-.05". The rack shall have a black wrinkle powder epoxy finish.

Model No.	Description	Rack Units*	Racking H	Overall D	Mtg Section D	Backbox D	Rack H	Overall H	Carton Pack
LWSRF-722	Wall-mount Swing-open Rack	7	12.38"	22.00"	19.06"	3.65"	16.63"	20.08"	1
LWSRF-1022	Wall-mount Swing-open Rack	10	17.63"	22.00"	19.06"	3.65"	21.88"	25.33"	1
LWSRF-1222	Wall-mount Swing-open Rack	12	21.13"	22.00"	19.06"	3.65"	25.38"	28.83"	1
LWSRF-1622	Wall-mount Swing-open Rack	16	28.13"	22.00"	19.06"	3.65"	32.38"	35.83"	1
RRTF-7	Rack rails with mounting hardware	7							1-pr
RRTF-10	Rack rails with mounting hardware	10							1-pr
RRTF-12	Rack rails with mounting hardware	12							1-pr
RRTF-16	Rack rails with mounting hardware	16							1-pr
RRTBF	Rail conversion bracket								1-set

*One Rack Unit (RU or U) = 1.75"

Model: LWSRF-series

Lowell Wall-mount Swing-open Rack with fixed-rails

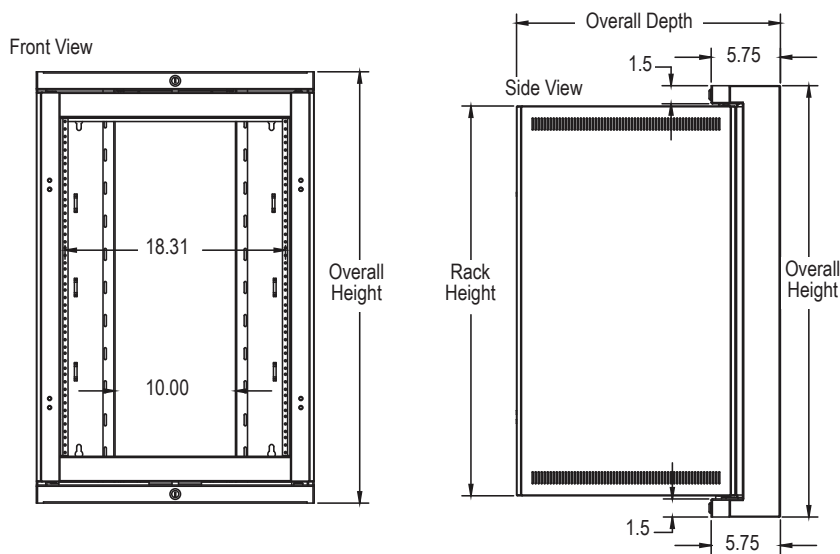
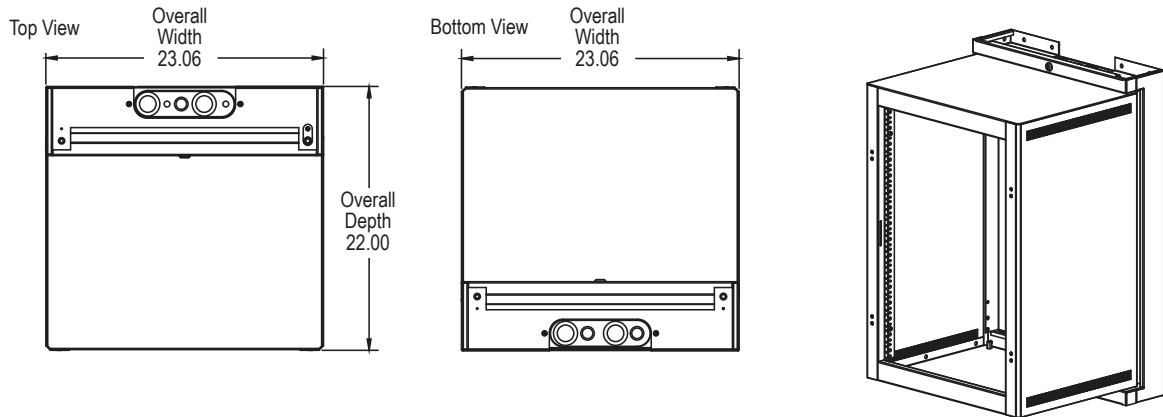

Corner Install Detail

Top View

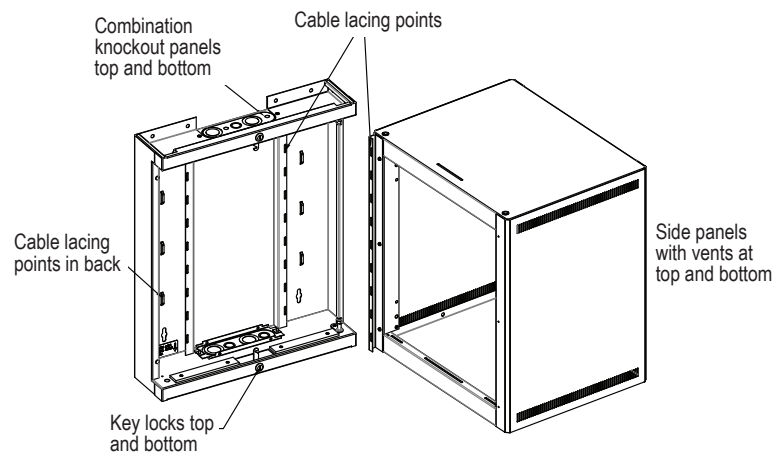
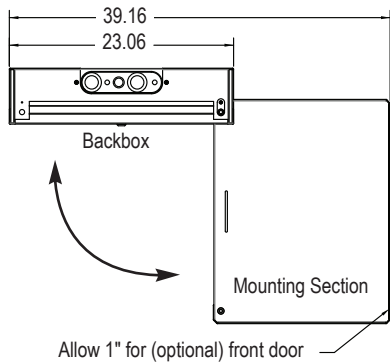

All measurements are inches.