



**MB FUSION
OWNER'S MANUAL**

MB FUSION

Congratulations!

Your purchase of a new Gallien-Krueger MB Fusion amplifier is surely the result of much careful consideration on your part. For our part, we at Gallien-Krueger are pleased that you chose us, and are determined that you will be a satisfied customer. In choosing a MB Fusion amplifier, you now own an amplifier with many unique features which will allow you to create your own distinct sound.

To get the most out of your new purchase, please take a few minutes to read through this manual. If you are in a hurry, we suggest you at least read through the Quick Start section before setting up your new rig. This will help get you started and give you a few quick tips, but is not a substitute for reading the rest of the manual.

Your amplifier should have come with the following items, please check the contents of the box to ensure that you have everything.

Included with your MB Fusion Amplifier:

Power cord	1
Owner's manual	1
Warranty card (U.S. only)	1
Safety instructions sheet	1
One button foot switch	1

If your MB Fusion amplifier did not come with all the items listed, or if you encounter problems while setting up your new equipment, please contact your local dealer or GK as soon as possible.

Gallien-Krueger, Inc.
2234 Industrial Drive
Stockton, CA 95206
phone: (209) 234-7300
fax: (209) 234-8420
Internet: www.gallien-krueger.com
Email: info@gallien.com

We wish you a lifetime of good playing and remember to always have fun!

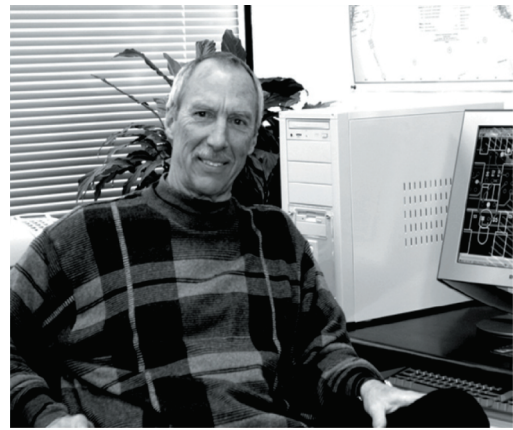

GK Philosophy

I have never seen the point in doing things the way others have done them. I also have not been very interested in following the latest fad. I'm a Stanford educated engineer who worked my way through school as a musician. Like all musicians, I have lugged amplifiers up stairways and into car trunks, always wondering why these things had to be so heavy, bulky, and hard to handle.

As the principal innovator at GK, our products reflect my attitudes and life experiences. I don't model my designs after other manufacturers' products. Instead, I believe new and old problems are best solved with new solutions. Having taken our own path, GK products enjoy a unique, unmatched sound, allowing you every opportunity to make an original statement.

Having supported my products for over thirty years, I have learned from the story they tell. Gallien-Krueger is a reflection of that story, and has a commitment to support that legacy. Just as the products I created over thirty five years ago are still telling their story, the products we create today will be talking to us tomorrow.

We'll be listening,

**Robert Gallien
Founder and President**

MB FUSION

Table Of Contents

Safety Information _____	4
Quick Start _____	5
Front Panel Controls _____	6
Top Panel and Rear Panel Features _____	7
Tech Talk _____	8-9
Installation and Maintenance _____	10
Sound Tips _____	11
Specifications _____	12

*All Features and specifications are subject to change without notice





Please read the Safety Information section on page 4 and installation instructions on page 10 before continuing.

Gallien-Krueger
2234 Industrial Drive
Stockton, CA 95206
phone: 209.234.7300
fax: 209.234.8420

email: info@gallien-krueger.com
internet: www.gallien-krueger.com

Warning!

This amplifier is capable of producing high sound pressure levels. Continued exposure to high SPL's can cause damage to your hearing. Always set the volume at a safe listening level or use hearing protection if the unit is operated at higher levels.

	CAUTION RISK OF ELECTRIC SHOCK DO NOT OPEN	
CAUTION: TO REDUCE THE RISK OF ELECTRIC SHOCK, DO NOT REMOVE TOP COVER. NO USER-SERVICEABLE PARTS INSIDE. REFER SERVICING TO QUALIFIED SERVICE PERSONNEL.		
	The lightning flash with arrow head symbol, within the equilateral triangle, is intended to alert the user to the presence of uninsulated "dangerous voltage" within the product enclosure that may be of sufficient magnitude to constitute a risk of electric shock to persons	
The exclamation point within an equilateral triangle, is intended to alert the user to the presence of important operating and maintenance (servicing) instructions in the literature accompanying the appliance.		
WARNING: TO REDUCE THE RISK OF FIRE OR ELECTRIC SHOCK, DO NOT EXPOSE THIS APPLIANCE TO RAIN OR MOISTURE		
CAUTION: TO PREVENT ELECTRIC SHOCK, MATCH WIDE BLADE OF PLUG TO WIDE SLOT, FULLY INSERTED.		
ATTENTION: POUR EVITER LES CHOCS ELECTRIQUES, INTRODUIRE LA LAME LA PLUS LARGE DE LA FICHE DANS LA BORNE CORRESPONDANTE DE LA PRISE ET POUSSER JUSQU'AU FOND.		

MB FUSION

Safety Information

Please read all enclosed safety precautions before connecting or operating this product.

Verify Line Voltage and Amperage: Your new MB Series Bass amplifier has been factory configured for use with the specific line voltage for your location:

120 Volt/60Hz 15 A circuit for USA/Canada.

230 Volt/(50/60Hz) 10 A circuit for UK/Australia.

230 Volt/(50/60Hz) 10 A circuit for Europe.

100 Volt/50Hz 15 A circuit for Japan.

220 Volt/50Hz 10 A circuit for Korea.

Proper AC circuit for all other countries.

Connecting the amplifier to a line with specifications other than indicated above can create safety and fire hazard, and may damage the amplifier. If you have any questions about the voltage requirements for your specific model, or about the line voltage in your area, contact your dealer before plugging the unit into a wall outlet.

Verify AC Circuit Capacity Before Use: The high power output of your amplifier may require heavy current draw under full-load conditions. To insure proper performance and avoid potential safety hazards, we recommend connection to line circuits with amperage specified “as above”. Connecting to the same circuit used by other heavy-power devices, such as high-wattage lights, may cause circuit breakers to trip. It is always a good idea to avoid using any audio equipment on the same AC circuit as equipment with motors, such as air conditioners or refrigerators. This will lessen the possibility of power variation and electrical start-up noise affecting your sound.

PLEASE REFER TO PAGE 10 FOR MORE INFORMATION TO SAFELY INSTALL THIS ITEM

AC Power Cord: To avoid safety hazards, use only the power cord supplied with your unit. If a replacement cord is needed, make certain to use a standard IEC compliant cord. Damaged power cords should be replaced immediately. When setting up, make certain that the AC plug is easily accessible. If you do not intend to use the amplifier for a considerable length of time, disconnect the plug from the AC Mains Socket. Do not use an extension cord.

Earth Grounding Connection: To prevent electric shock, do not remove the grounding plug on the power cord, or use any plug or extension cord that does not have a grounding plug provided. Make certain that the AC outlet is properly grounded as well. Do not use an adapter plug with this product.

Do Not Open the Amplifier Enclosure: There are no user serviceable parts inside this product. Opening the amplifier enclosure may present a shock hazard. Modification to the product will void your warranty. If liquid enters the unit, or any metal object such as a paper clip accidentally falls inside the enclosure, disconnect the unit from the AC power source immediately and consult an authorized service station.

Setup: To insure proper operation and to avoid potential safety hazards, place the unit on a firm, level surface. Do not plug or unplug the instrument or speaker cable while the amplifier power is on.

Speaker Cables: To prevent electric shock, use “Class II Wiring” speaker cables or cables with double or reinforced insulation when connecting to speaker cabinet.

Heat & Ventilation: Make sure there is space provided for proper ventilation. Avoid using in extremely hot or cold locations and areas that are exposed to direct sunlight or near heating equipment. Avoid using in moist or high humidity areas.

NEVER BLOCK THE FAN VENT HOLES ON THE SIDES OF THE UNIT

MB FUSION

Quick Start

The MB Series amplifier is designed to be simple to operate. All controls have a well defined purpose. These directions will take you through the basics and give you a good start for setting up your sound.

1. Plug it in: Set the power switch to Off and connect the supplied power cord, from the amplifier AC receptacle, to an AC power outlet of proper voltage and power rating (see safety information on page 5 for details).

2. Connect your cabinets: Connect your speaker cabinets to the amplifier outputs marked Speaker. The MB features dual use speaker connections. These unique jacks allow for Speakon or 1/4" plugs to be used. Be sure not to exceed the recommended speaker load as noted below.

Maximum Recommended Speaker Loads: One 4 Ohm, or two 8 Ohm cabinets.

3. Initial front panel control settings: Set all EQ controls and contour knob to 12 o'clock. Set the Gain A, Gain B, Master A and Master B controls at 0. The A/B button (between Bass and Master A knobs) should be in the out position.

4. Plug in your bass: Using an instrument (shielded) cable, connect your bass to the input jack and press the power switch on. If you have active tone controls on your bass, turn all of the controls to the middle or flat position and turn the volume all the way up. If you have conventional, passive tone controls, turn all tone and volume controls all the way up.

5. Level and Master Volume settings: Set the Master A volume to 3 o'clock. Turn the Gain A knob up as you play to the desired output level. If distortion occurs at low gain settings press the -14db pad button in and turn the Gain A volume knob up. If the signal is still distorting, reduce the volume on your bass.

6. Boost/Master B: Engage the button located between the boost and master B knobs. This will activate the boost section of the pre amp. This can also be done with the included foot switch. Turn up the Gain B and Master B knobs to the desired volume and gain levels.

You should be hearing your bass quite well through the Master A and Master B channels. At this point you can experiment with different EQ, Contour and Gain settings.

MB FUSION

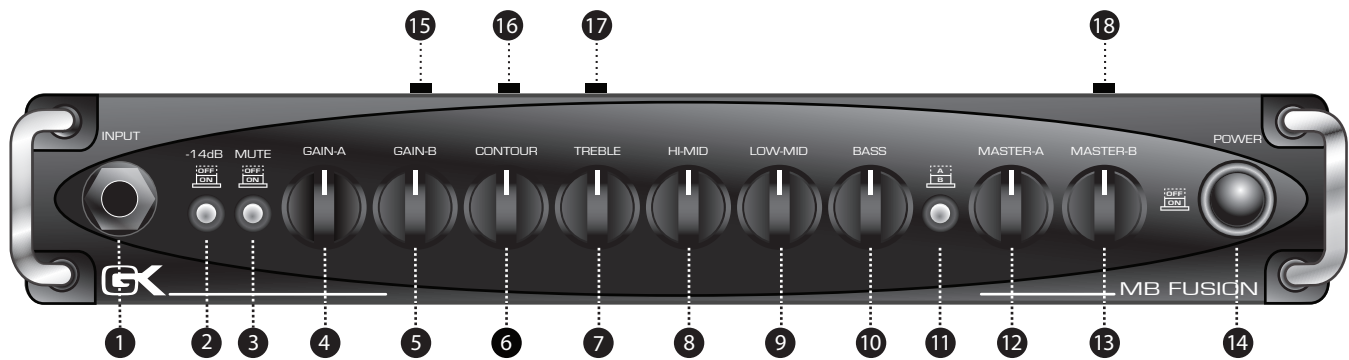

Front Panel Features

- 1 Input:** A standard ¼" input jack to connect active or passive basses using a shielded cord.
- 2 -14 dB Pad/Clip indicator:** Input attenuator button. This button is generally set to the out position except in cases where the input signal overloads causing distortion. It may be necessary to "pad" the input if you are using a bass with active electronics or very high output. If the -14dB is pressed and the signal distorts at lower settings reduce the volume on your bass.
- 3 Mute:** Set this switch to "on" when tuning or unplugging your bass. No signal will be sent to the speakers or the P.A. system. When muted this button turns red.
- 4 Gain A:** Sets the preamp gain after the input stage. It is used in conjunction with the input pad to control the signal level sent throughout the amplifier.
- 5 Gain B:** Allows an additional input level setting to be preset and activated via footswitch or from the front panel's A/B button. When used in conjunction with the Master B knob, varying the amounts of tube overdrive and volume are available.
- 6 Contour:** As part of the amps active equalization the contour control decreases the mid-range frequencies while boosting low and high frequencies.
- 7 Treble:** Boost and cut at 7 kHz +14 dB shelving type. Use this control to add or remove edge and definition.
- 8 Hi-Mid:** Boost and cut at 1 kHz +6 dB. A "Q Optimized" band pass type, this works on lower string harmonics and effects the punch of your sound.
- 9 Low-Mid:** Boost and cut at 250Hz +6dB/-10 dB. A "Q optimized" band pass type, this works for main body of your sound.
- 10 Bass:** Boost and cut a 60Hz +10 dB, shelving type. This is used to control the low end push.
- 11 A/B:** This button activates the Gain B and Master B volume control. This can also be activated using the foot switch (included).
- 12 Master A:** This is the master volume control when the boost is inactive.
- 13 Master B:** This is the master volume control when boost is activated.
- 14 Power Switch:** Turns the amplifier on and off. In the on position, the ring surrounding the button will light red during power up then changes to blue, indicating the amp is ready for normal operation. Should the amp experience a fault (over heat or over current) the amp will mute and the ring will light red until the condition is corrected. This LED turns off when the power is switched off. This turns the amp off but it does not completely disconnect the power from the AC mains.

Top Panel Features

- 15 Contour:** The Contour switch activates a tube driven version of the contour circuit from the RB series. It adds a variable control and center frequency select for precise tone shaping. With the control a zero, the response is 'flat' as in no shaping. As the Contour is increased, it scoops out the midrange. Additionally, it compensates to keep the overall volume level constant.
- 16 Presence:** The Presence control adds extra sparkle on the high end for better clarity and openness in your tone. This is particularly useful when soloing or playing chords. (continued on pg. 7)

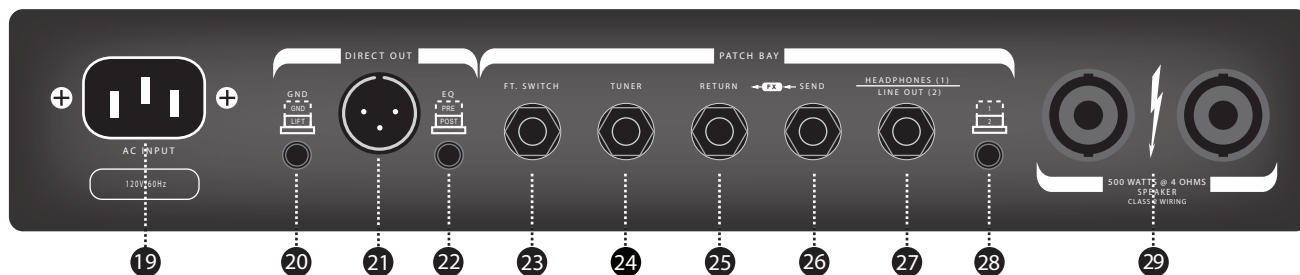

Top Panel Features (continued)

- 17 **Deep:** The Deep switch extends the low frequency range of the amplifier to accommodate the extra low range of the B string on a 5 or 6 string bass. Users of 4 string basses may also find interesting and desirable results with this filter as well.
- 18 **Limiter:** When this button is engaged it prevents the power amp from distorting. It is recommended that this feature is used for during high volume applications.
- 27 **Headphone/Line out:** When switched, this output allows the user to send a direct (unbalanced) line out to devices with unbalanced inputs such as personal multitrack recorders. This connection requires a shielded patch cord. Unswitched, this headphone jack can be used to monitor your playing with headphones.

Rear Panel Features

- 28 **Headphone/Line out switch:** This switch toggles the output from headphone to line out.
- 29 **Speaker:** Power amp output to speaker cabinet. Delivers 500w into 4 Ohm loads. Lower impedances such as 8 Ohms or 16 Ohms and no load are acceptable. One 4 Ohm speaker and one 8 Ohm speaker is not recommended. This unique speaker output allows you to use a 1/4" plug or the high current, twist-lock Speakon connector.
- 19 **AC Receptacle:** The detachable power cord plugs in here.
- 20 **Ground Lift:** This switch disconnects the ground of the balanced, XLR output to eliminate hum and buzz when connecting to equipment that is running on a different ground system.
- 21 **Balanced Direct Out:** This electronically balanced output allows a direct connection to a P.A. system.
- 22 **Pre/Post EQ Button:** This button switches the direct out signal to be before or after the EQ.
- 23 **Foot switch Input:** A foot switch is provided to engage Boost and Master B modes.
- 24 **Tuner Output:** This output comes directly off of the input stage and can be patched to a tuner using a shielded patch cord. This output is unaffected by the Tuning Mute Feature.
- 25 **Return:** This input allows the signal from outboard effects devices to be inserted before the boost section.
- 26 **Send:** This output allows signal from the preamp to be fed to outboard effects devices from a point after the EQ section.

Tech Talk

GK amplifiers are designed to be flexible and user friendly for maximum performance. This is accomplished through these important features:

Active Equalization: There are a wide variety of equalizers used in instrument amplifiers today. Passive equalizers are great but only allow you to cut (signal loss), not boost (signal gain). Graphic equalizers provide plenty of variation, but are much better for room equalization. When used with instruments, they tend to sound unnatural or synthetic. The equalizer in GK amplifiers is unique in the industry and reflects over and reflects over 30 years of continuous development and refinement. We've developed a rotary, four-band, vacuum tube active equalizer optimized for bass guitar. The active circuitry allows you to either boost or cut at a given frequency with greater integrity in signal reproduction. The treble is a shelving type control that boosts the high frequencies evenly. Respectively, the bass is a shelving control that evenly boosts the low frequencies. The high mid and low mid are peak (band pass) type controls with wide Q (bandwidth) patterns which are much more musical sounding. Each of the four bands are connected in series, meaning the output of the first band is fed directly into the input of the next and so on. This eliminates the rippling or combing effect that can happen with parallel EQ circuits. The overall result from all of this is an equalizer that's flexible, yet easy to use and sounds natural even at extreme settings.

Shaping: The three-stage shaping filter simplifies the process of shaping and coloring your tone, enabling the amplifier to accommodate a wide variety of playing styles with minimal fuss.

Contour: The Contour is a tube-driven version of the contour circuit from the RB Series. It adds a variable control and center frequency select for precise tone shaping. With the control at zero, the response is essentially 'flat' (as in no shaping). As the contour is increased, it scoops out the midrange. Additionally, it compensates to keep the overall volume level constant. With it's variable control, the Contour will accommodate everyone from the smooth finger style player to the aggressive slap player.

Deep: The Deep switch extends the low frequency range of the amplifier to accommodate the extra low range of the B string on 5 and 6 string basses. Players of four string basses may also find desirable results with this filter as well.

Presence: The Presence control adds extra sparkle on the high end for better clarity and 'openness' in your tone. This is particularly useful when soloing or playing chords.

Tech Talk

Characteristics of the MB Fusion: The MB Fusion is a flexible, state of the art amplifier designed to deliver maximum performance while remaining small, lightweight and simple to operate. This is accomplished through a few, very important features:

- **Six stage tube preamp**
- **Class D power supply and power amp.**
- **Four, Bass specific bands of active equalization for precise tone control.**
- **Balanced direct output eliminates the need for a direct box.**
- **Continuously variable fan cooling.**

Equalization: Standard tone controls and graphic equalizers give you plenty of variation, but they don't provide what the instrument really needs. The fact is, graphic equalizers are intended for room equalization. The equalization in Gallien-Krueger amplifiers reflects 40 years of continuous development and refinement.

The GK equalizer is unique to the industry, it's not just a normal four band equalizer, each section is a special circuit optimized to perform a bass specific job in its range of operation.

These sections are wired in series, so they add to one another creating a tremendously flexible equalizer, that sounds natural at any setting. Now it is possible to obtain the sound you desire.

Contour: The Contour control is used to completely revoice the amplifier. The Contour control tunes between two different shaping circuits, with greatly different responses. With the control all the way up, the low end is slightly boosted, the mids are dropped and the high end is pushed up. This feature is only found in GK amplifiers.

G.I.V.E. Technology: As in all GK pre-amps, the MB Fusion pre-amp incorporates what we call G.I.V.E (Gate Induced Valve Effect) technology. We use field effect devices with the gate biased in a way that emphasizes the optimum harmonic content of the signal. Working in concert with our unique four band active equalizer, and three stage voicing filter section, G.I.V.E. technology produces a consistently pleasing bass tone.

Cool Running = Reliability: To cool the amp when its being driven hard, we've designed a temperature sensitive fan cooling system. When the amp is under a light load, the fan is off or running at a low speed, reducing fan noise. As the amp works harder, the fan speed increases to keep everything cool.

Smart Protection Circuitry: The MB Fusion protection circuitry constantly monitors for unsafe operating conditions such as short circuits, poorly wired speaker cables, blown speakers, improper ventilation, and incorrect speaker configurations. In addition, protection is provided during power up/down. If the MB Fusion senses any unsafe operating conditions, the output signal is immediately muted and the power light changes from blue to red. The amplifier will remain muted until the fault is removed. If the protection circuit activates while playing, turn the amplifier off and check the amplifier speaker output connections. Be sure that you are not exceeding the maximum recommend load described in this manual. If the problem persists, contact GK directly for technical advice.

In Closing, you should now have a thorough understanding of how your new MB Fusion amplifier works and what advantages it can offer you in getting "your" sound. We thank you for reading the Owner's Manual and wish you the best of times! Please send us your comments via www.gallien-krueger.com or e-mail us at sales@gallien.com.

MB FUSION

Installation: To insure proper operation and to avoid potential safety hazards, place the unit on a firm, level surface.

Ventilation: Make certain that proper space is provided for ventilation. Never block the fan vent holes located on the sides of the amplifier. If the amplifier will be installed in a rack or other enclosed area, make sure that there is sufficient air movement within the enclosure to allow proper cooling. Consult your dealer for more information. Avoid installation in extremely hot or cold locations, and areas that are exposed to direct sunlight, or near heating equipment. Avoid moist or humid locations.

Remember, power amplifiers generate heat. The ventilation slots on the enclosure are specifically designed to remove this heat. Blocking or placing other electronic equipment near the heat dissipation system may possibly affect the long term reliability of both your amplifier and the other equipment.

Moving the Unit: Before moving the unit, be certain to disconnect any interconnection cords with other components, and make sure that you disconnect the unit from the AC outlet.

Cleaning: When the unit gets dirty, clean only with a dry cloth. Never use benzene, thinner, alcohol, or other volatile cleaning agents. Do not use abrasive cleaners, as they may damage the finish of metal parts. Avoid spraying insecticides near the unit.

Maintenance: Your new amplifier is rugged. It was built to give you a lifetime of trouble free operation, if it is operated in accordance with the instructions contained in this manual. The only maintenance required is cleaning and the occasional tube replacement. If you are going to move your amplifier around frequently, we recommend a road case to protect it from scratches and road wear.

Packaging: The carton and packing materials used in shipping your new amplifier were specifically designed to cushion it from the shocks and vibration that occur during transport. We suggest that you save the carton and packing materials for use in shipping, in the event you move, or the amplifier needs repair.

MB FUSION

Sound Tips

The MB Fusion has several unique features which, if used properly, will obtain the sound you have been searching for.

The Equalizer: The Equalizer is used to fine tune your sound. When adjusting making adjustments, do it just a little at a time. These are active circuits and small changes can make a big difference in your sound. With a little experimentation you will find that this equalizer is very easy to use and provides you with a large variety of great sounds unique to GK.

Contour: Increasing the Contour level will scoop out midrange frequencies while boosting the highs and lows. The sound, once again, is unique to GK and available on any other Bass amp. Lower contour settings are recommended for midrange clarity at higher playing levels.

Gain and Master A/B: The Gain A/B settings determine the overall drive of the signal. Lower settings will allow for the cleanest sound, while higher settings will result in an overdriven signal as the tubes distort. For high volume applications where maximum headroom is desired, the Master A/B knobs should be set a 3 o'clock or higher.

Direct Out: The MB Fusion provides a low noise, high quality balanced direct output for connection to PA and recording consoles. A Ground Lift switch is included to remove hum and buzz when connecting to equipment powered by a different ground system.

With the Pre/Post EQ switch set to "Pre" (Out), the direct output signal is fed directly from the input stage providing a low noise output superior to external direct boxes and impedance transformers. In the "Pre" position, the direct output signal is only effected by the Input Volume, -14db Pad and Mute. This allows you to adjust your tone and volume on stage without changing the Direct Output signal level and confusing your sound man.

Changing the Pre/Post EQ switch to "Post" (In), sends the "GK Sound" (EQ settings etc.) and preamp response to the Direct out jack. This gives you complete control over the Direct out's tone and volume.

MB FUSION BLOCK DIAGRAM

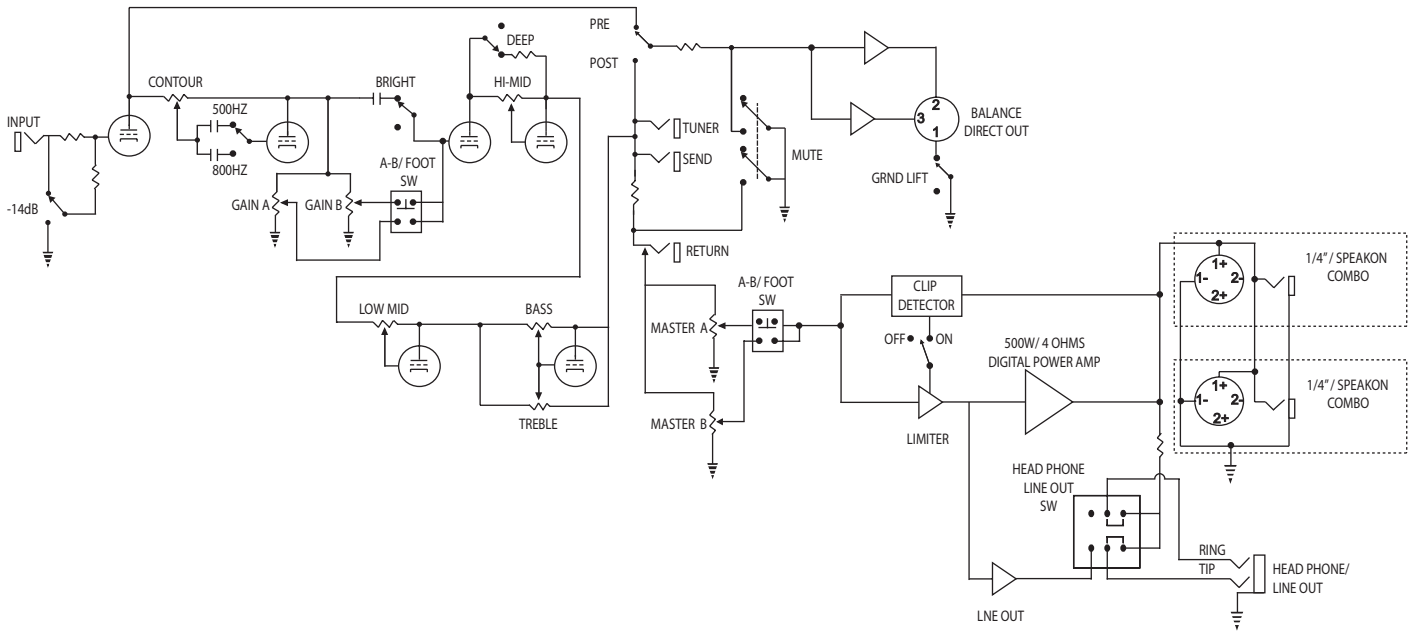

Specifications

SPECIFICATIONS

Power Output:	350W @ 8 Ohms 500W @ 4 Ohms
Audio Inputs:	
Instrument Input	1/4" Mono, Unbalanced
Level	0.6 Vrms
w/ -14dB	1.6 Vrms
Impedance	1 M Ohm
Return Input	1/4" Mono, Unbalanced
Impedance	50k Ohms
Audio Outputs:	
Send Output	1/4" Mono, Unbalanced
Impedance	220 Ohms
Tuner Output	1/4" Mono, Unbalanced
Impedance	10K Ohms
Direct Out	XLR, Balanced
Impedance	500 Ohms
Speaker Out	1/4"/Speakon Jack Combo, x2
Equalizer:	
Bass	+/-14dB @ 40Hz
Lo-Mid	+6/-9dB @ 250Hz
Hi-Mid	+5/-8dB @ 1kHz
Treble	+10/-19dB @ 7kHz
Voicing Filters:	
Contour	-16dB @ 500Hz or -15dB @ 800Hz
Deep	+4dB @ 30Hz
Bright	+4dB @ 10kHz

Noise:	-90dB "A" weighted
Cooling:	Variable Speed Fan
Protection:	Full short circuit, thermal, RF protection. Stable into reactive and mismatched loads. Five second muted warm-up.
Dimensions:	1.75" [44.45mm] High 11.00" [279.40mm] Wide 9.75" [274.65mm] Deep 1 Rack space
Weight:	4.5lbs.
Consumption:	580W (Full) 75.6W (Average)
Mains Voltage:	USA/CANADA 120 Volts, 60Hz UK/Australia 240 Volts, 50Hz Europe 230/240 Volts, 50/60Hz Japan 100 Volts, 50/60Hz Korea 220 Volts, 50 Hz
Mains:	Standard IEC Receptacle.
Build and Certified Under IEC 60065 INTERNATIONAL SAFETY STANDARD.	



MB FUSION HYBRID BASS AMPLIFIER
OWNER'S MANUAL
PART # 160-0540-A